

Based on National Curriculum of Pakistan 2022-23

Textbook of Computer Science **GRADE 10**

"Not for Sale"
Published for free distribution to the
students of Islamabad Model Schools
and Colleges under Federal Directorate
of Education, Islamabad



Algorithm

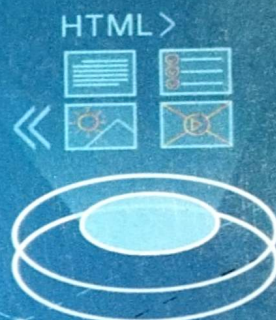

NATIONAL BOOK FOUNDATION
AS
FEDERAL TEXTBOOK BOARD, ISLAMABAD



Based on National Curriculum of Pakistan 2022-23

Textbook of
Computer Science
Grade
10

National Curriculum Council
Ministry of Federal Education and Professional Training



National Book Foundation
as
Federal Textbook Board
Islamabad

Table of Contents

Unit 1: Computer Systems

1.1	Machine Level Representation of data	8
1.2	Numbering Systems	9
1.3	Common Coding Schemes (ASCII and Unicode)	24
1.4	Operating System	26
1.5	Computer Software.....	36

Unit 2: Computational Thinking & Algorithms

2.1	Computing Problems	54
2.2	Basics of Counting Problems	55
2.3	Basic Counting Principles	56
2.4	Algorithms and their Characteristics	59
2.5	Logical Reasoning.....	60
2.6	Standard Algorithms.....	62
2.7	Steps in algorithm to solve computational problems	63
2.8	Abstraction	64
2.9	Creating Generalized Solutions	65
2.10	Modular Design	66
2.11	Algorithm Dry Run.....	67
2.12	Errors	69

Unit 3: Programming Fundamentals

3.1	Website Development.....	75
3.2	Additional Features of HTML/CSS.....	76
3.3	Advanced Programming Constructs in JavaScript	92
3.4	Complex Algorithms in JavaScript.....	102
3.5	Advanced techniques for testing and debugging	106

Unit 4: Data and Analysis

4.1	Data Science	117
4.2	Data Visualization	126
4.3	Stages of the Data Science Life Cycle	134

Unit 5: Applications of Computer Science

5.1	Internet of Things (IoT)	148
-----	--------------------------------	-----

5.2	Foundational Components of IoT	148
5.3	Applications of IoT	151
5.4	Blockchain Technology	156
5.5	Applications of Blockchain	156
5.6	Cloud Computing	158
5.7	Speech Recognition and Voice Recognition.....	160
5.8	Natural Language Processing	163
5.9	Robotics	165
5.10	Bias and Unethical use of Artificial Intelligence.....	168
5.11	Responsibilities of AI System Designers	169
Unit 6: Impacts of Computing		
6.1	What is Technology Addiction	175
6.2	Internet.....	177
6.3	The Effects of Threats to Individual Privacy and Security.....	180
6.4	Cloud Computing	181
6.5	Hardware and Software Method to Protect Devices	183
6.6	Cybersecurity.....	185
6.7	Safety and Security Concept	187
6.8	Cyberbullying.....	188
6.9	The Environmental, Cultural and Human Impact of Computing and Assistive Technologies.....	190
6.10	Digital Divide.....	191
6.11	Inequitable Access to Information.....	192
Unit 7: Digital Literacy		
7.1	Information Collection.....	200
Unit 8: Entrepreneurship in Digital Age		
8.1	Qualitative vs. Quantitative Research Differences, Examples & Methods	221
8.2	The differences between quantitative and qualitative research	222
8.3	Questionnaire Design Methods, Question Types & Examples	226
8.4	What is Market Validation?	231
8.5	How to Use Research to Create Customer Profiles	234
8.6	Business Pitching: Identifying Problems and Creating Solutions	238

Introduction

A computer system is an essential part of modern life. It has changed how we work, communicate, learn, and have fun. A computer system isn't just one device; it's a mix of hardware (physical parts) and software (programs) that work together to process information, solve problems, and do many tasks.

Understanding computer systems is very important today, whether you're just using it for basic things or working as a professional in technology. Knowing how they work helps us use computers for many purposes, like business, science, creativity, and entertainment.

1.1 Machine Level Representation of data

"Machine level representation of data" refers to how information is encoded and stored in a computer's memory, which is understood by the machine's hardware. At this level, data is represented using binary digits (bits), which are either 0s or 1s.

Binary Representation:

At the machine level, all data is represented using binary digits. A binary digit, or a bit, can have one of two states: 0 or 1. These bits are the fundamental units of information in a computer. For example:

- ▶▶▶ The decimal number 5 is represented in binary as 101.
- ▶▶▶ The ASCII character 'A' is represented as 01000001 in binary.
- ▶▶▶ A color in an image might be represented as a combination of binary values for red, green, and blue components.

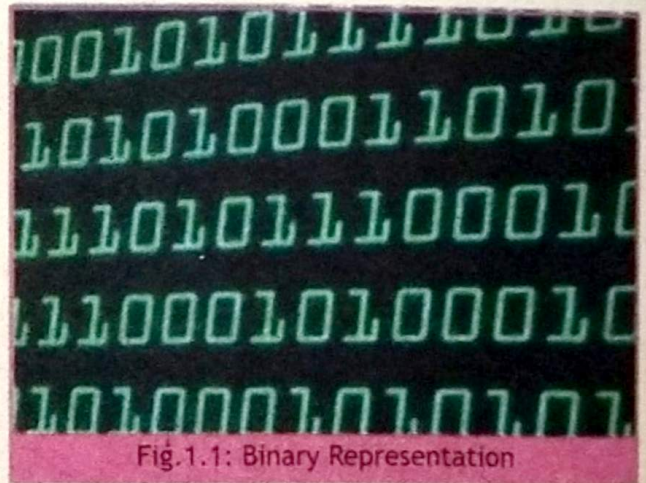

Fig.1.1: Binary Representation

Data Types:

Different types of data are represented in different ways at the machine level. Common data types include integers, floating-point numbers, characters, and Boolean values.

Integers: Integers are represented using a fixed number of bits, with the most significant bit (leftmost bit) indicating the sign (positive or negative). For example, an 8-bit integer can represent values from -128 to 127 (signed) or 0 to 255 (unsigned).

Floating-Point Numbers: A floating point number, is a positive or negative whole number with a decimal point. For example, 15.5, 0.45, and -203.345 are all floating point numbers.

Characters: Characters are represented using character encoding schemes such as ASCII or Unicode, where each character is assigned a unique binary code. For example, the ASCII code for the letter 'A' is 65 (01000001 in binary).

Boolean Values: Boolean values, representing true or false, can be represented using a single bit, where 0 typically represents false and 1 represents true.

1.2 Numbering Systems

Number System:

A number system is a way of writing and showing numbers. It uses specific digits or symbols to represent numbers. It helps us organize and understand numbers within a certain group. Number systems also make it easier to do basic math operations like addition, subtraction, multiplication, and division.

A Number:

A number is a mathematical value used for counting or measuring or labelling objects. Numbers are used to perform arithmetic calculations. Examples include: 20, 45, -10, 3.4, 11.5, -75.6, etc.

1.2.1 Types of Number Systems

There are various types of number systems in mathematics. The four most common number system types are:

- »»» Decimal number system (Base- 10)
- »»» Binary number system (Base- 2)
- »»» Octal number system (Base-8)
- »»» Hexadecimal number system (Base- 16)

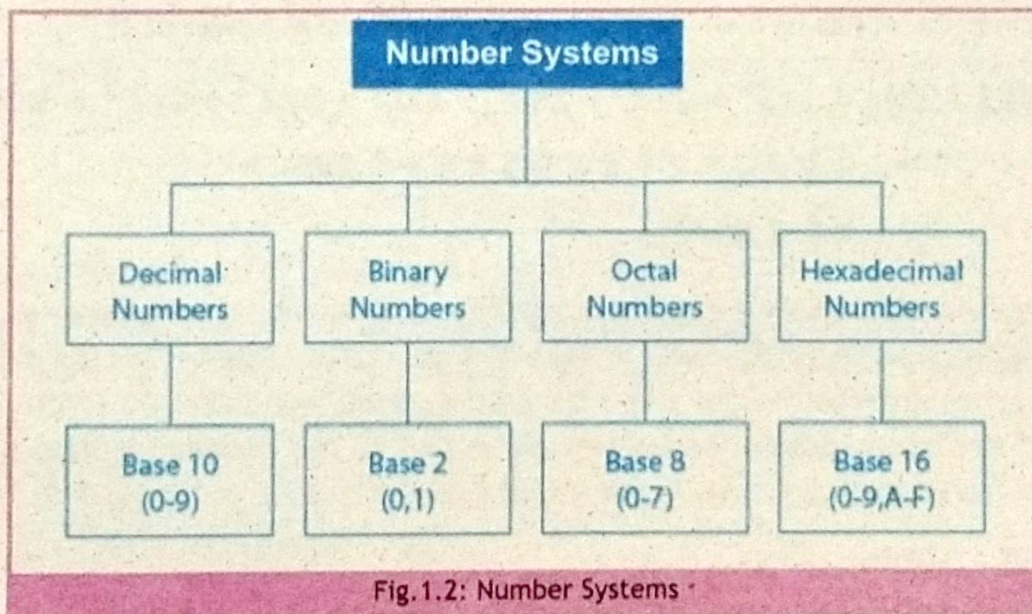

Fig. 1.2: Number Systems

Decimal Number System

The decimal (also called Denary) number system is composed of the 10 symbols: 0, 1, 2, 3, 4, 5, 6, 7, 8 and 9. Using these symbols we can express any quantity. The decimal number system is called base 10 system because it has 10 digits. The decimal number system is a positional-value system, in which the value of a digit depends on its position in the number. For example, consider the decimal number 964. Here:

9 represents 9 hundreds

6 represents 6 tens

4 represents 4 units

The 9 carries the most weight. It is called the Most Significant Digit (MSD). The 4 carries the least weight and is called the Least Significant Digit (LSD). Each digit of a number carries weight that can be expressed as powers of 10. This is shown below, where the number 2745.214 is represented. The decimal point separates the positive powers of 10 from the negative powers.

$$\begin{aligned}(8745.215)_{10} &= 8 \times 10^3 + 7 \times 10^2 + 4 \times 10^1 + 5 \times 10^0 + 2 \times 10^{-1} + 1 \times 10^{-2} + 5 \times 10^{-3} \\ &= 8000 + 700 + 40 + 5 + 0.2 + 0.01 + 0.005 \\ &= 8745.215\end{aligned}$$

In general, any number is simply the sum of the products of each digit value times its positional value.

Binary Number System

In binary number system there are only two symbols or digits, 0 and 1. The base of binary number system is 2. All the statements made earlier about the decimal number system are equally applicable to the binary number system as well. The binary system is also a positional-value system, wherein each bit has its own value or weight expressed as power of 2.

$$\begin{aligned}(1011.101)_2 &= 1 \times 2^3 + 0 \times 2^2 + 1 \times 2^1 + 1 \times 2^0 + 1 \times 2^{-1} + 0 \times 2^{-2} + 1 \times 2^{-3} \\ &= 8 + 0 + 2 + 1 + 0.5 + 0 + 0.125 \\ &= (11.625)_{10}\end{aligned}$$

The binary number $(1011.101)_2$ is represented above and its equivalent decimal value can be found by taking the sum of the products of each bit value (0 or 1) times its positional value. The left most bit carries the most weight and it is called the Most Significant Bit (MSB). The positions to the right of the binary point are negative powers of 2. The right most bit carries the least weight and is referred to as the least significant bit (LSB).

Octal Number System

The Octal number system has a base of 8, meaning it has eight possible digits; 0, 1, 2, 3, 4, 5, 6, and 7. Thus, each digit of an octal number system can have any value from 0 to 7. The digit positions in an octal number system have weight with powers of 8. An octal number can be easily converted to its decimal equivalent by multiplying each digit by its positional weight.

For example,

$$(672)_8 = 6 \times 8^2 + 7 \times 8^1 + 2 \times 8^0 = 384 + 56 + 2 = (442)_{10}$$

Another example:

$$(25.6)_8 = 2 \times 8^1 + 5 \times 8^0 + 6 \times 8^{-1} = 16 + 5 + 0.75 = (21.75)_{10}$$

Hexadecimal Number System

The hexadecimal number system uses base 16. Thus it has 16 possible digits. It uses the digits 0 - 9 and letters A, B, C, D, E and F as the 16 digit symbols. The table shows the relationship among hexadecimal and decimal numbers. It is important to remember that hexadecimal digits A through F are equivalent to the decimal values 10 through 15.

Hexadecimal	0	1	2	3	4	5	6	7	8	9	A	B	C	D	E	F
Decimal	0	1	2	3	4	5	6	7	8	9	10	11	12	13	14	15

A hexadecimal number can be converted to its decimal equivalent by using the fact that each digit position has a weight that is power of 16. The LSD has a weight of $16^0 = 1$ the next higher digit has a weight of $16^1 = 16$, the next higher digit has a weight of $16^2 = 256$, and so on.

The conversion process is shown below.

$$\begin{aligned} (3AF)_{16} &= 3 \times 16^2 + 10 \times 16^1 + 15 \times 16^0 = 768 + 160 + 15 \\ &= (943)_{10} \end{aligned}$$

1.2.2 Conversions from one Number system to the other

Conversion from any Base to Base-10(Decimal)

To convert a number from any base to base-10 (decimal), you need to convert each digit of the number to its decimal equivalent. Then, you use base-10 arithmetic to expand the number by multiplying each digit by the base raised to the power of its position (starting from 0 on the right). Finally, add the results together to get the decimal value.

i. Conversion from Binary to Decimal

Example 1: $(10111)_2$ to (?)₁₀

$$\begin{aligned} (10111)_2 &= (1 \times 2^4) + (0 \times 2^3) + (1 \times 2^2) + (1 \times 2^1) + (1 \times 2^0) \\ &= 16 + 0 + 4 + 2 + 1 \\ &= (23)_{10} \end{aligned}$$

Example 2: $(100101.1011)_2$ to (?)₁₀

$$\begin{aligned} (100101.1011)_2 &= (1 \times 2^5) + (0 \times 2^4) + (0 \times 2^3) + (1 \times 2^2) + (0 \times 2^1) \\ &\quad (1 \times 2^0) + (1 \times 2^{-1}) + (0 \times 2^{-2}) + (1 \times 2^{-3}) + (1 \times 2^{-4}) \\ &= 32 + 0 + 0 + 4 + 0 + 1 + (1/2) + (0) + (1/8) + (1/16) \\ &= 37 + (11/16) \\ &= 37 + 0.6875 \\ &= (37.6875)_{10} \end{aligned}$$

ii. Conversion from Octal to Decimal

Example: $(437)_8$ to (?)₁₀

$$\begin{aligned}(437)_8 &= (4 \times 8^2) + (3 \times 8^1) + (7 \times 8^0) \\ &= (4 \times 64) + (3 \times 8) + (7 \times 1) \\ &= 256 + 24 + 7 \\ &= (287)_{10}\end{aligned}$$

iii. Conversion from Hexadecimal to Decimal

Example: $(1BE8)_{16}$ to (?)₁₀

$$\begin{aligned}(1BE8)_{16} &= (1 \times 16^3) + (B \times 16^2) + (E \times 16^1) + (8 \times 16^0) \\ &= (1 \times 16^3) + (11 \times 16^2) + (14 \times 16^1) + (8 \times 16^0) \\ &= (1 \times 4096) + (11 \times 256) + (14 \times 16) + (8 \times 1) \\ &= 4096 + 2816 + 224 + 8 \\ &= (7144)_{10}\end{aligned}$$



Activity-1

a. Convert the following Binary numbers to Decimal

- i. 11100011 ii. 101010101 iii. 11001.1001 iv. 10001.111

b. Convert the following Octal numbers to Decimal

- i. 3452 ii. 1256 iii. 7454 iv. 2743

c. Convert the following Hexadecimal numbers to Decimal

- i. AB01F ii. FE162B iii. 9C17D iv. 8D00A

Conversion from Base-10(Decimal) to any other Base

To convert a decimal number to any other number:

- Divide the decimal number to be converted by the value of the new base and record the remainder as the LSD of the new base number.
- Divide the quotient of the previous division by the new base again and record the remainder as the next digit to the left of the new base number.
- Repeat this process, until the quotient becomes zero or not divisible by the base.
- Note that the last remainder obtained will be the MSD of the new base number.

The following examples will demonstrate the above method by converting the decimal numbers to their binary, octal and hexadecimal equivalents, respectively.

I. From Decimal to Binary

Converting the Integer Part:

- Divide the integer part by 2.
- Record the remainder (0 or 1).
- Update the integer part to the quotient.
- Repeat steps 1-3 until the integer part is 0.
- The binary representation is the remainders read in reverse order.

Converting the Fractional Part:

- Multiply the decimal part by 2.
- Record the integer part (0 or 1). This becomes the next binary digit.
- Remove the integer part from the product, leaving only the decimal part.
- Repeat the process with the new decimal part.
- Continue until the decimal part becomes 0 or until you have reached the desired precision.
- The binary representation is the sequence of recorded integers.

Example 1: $(179.257)_{10}$ to $(\quad?)_2$

Step 1: Converting integer part 179 to binary

2	179	Remainder
2	89	1
2	44	1
2	22	0
2	11	0
2	5	1
2	2	1
	1	0

$(179)_{10} = (10110011)_2$

Step 2: Converting fractional part 0.257 to binary

	Binary
$0.257 \times 2 = 0.514$	0
$0.514 \times 2 = 1.028$	1
$0.028 \times 2 = 0.056$	0
$0.056 \times 2 = 0.112$	0
$0.112 \times 2 = 0.224$	0
$0.224 \times 2 = 0.448$	0
$0.448 \times 2 = 0.896$	0
$0.896 \times 2 = 1.792$	1

$(0.257)_{10} = (0.0100001)_2$

So, $(179.257)_{10} = (10110011.0100001)_2$

Example 1: $(179.257)_{10}$ to $(\quad?)_2$

Step 1: Converting integer part 179 to binary

2	179	Remainder
2	89	1
2	44	1
2	22	0
2	11	0
2	5	1
2	2	1
	1	0

$(179)_{10} = (10110011)_2$

Step 2: Converting fractional part 0.257 to binary

	Binary
$0.257 \times 2 = 0.514$	0
$0.514 \times 2 = 1.028$	1
$0.028 \times 2 = 0.056$	0
$0.056 \times 2 = 0.112$	0
$0.112 \times 2 = 0.224$	0
$0.224 \times 2 = 0.448$	0
$0.448 \times 2 = 0.896$	0
$0.896 \times 2 = 1.792$	1

$(0.257)_{10} = (0.0100001)_2$

So, $(179.257)_{10} = (10110011.0100001)_2$

ii. From Decimal to Octal

Example 1: $(165)_{10}$ to $(?)_8$			Example 2: $(331)_{10}$ to $(?)_8$		
8	165	Remainder	8	331	Remainder
8	20	5	8	41	3
8	2	4	8	5	1
$(165)_{10} = (245)_8$			$(331)_{10} = (513)_8$		

iii. From Decimal to Hexadecimal

Example 1: $(739)_{10}$ to $(?)_{16}$			Example 2: $(3501)_{10}$ to $(?)_{16}$		
16	739	Remainder	16	3501	Remainder
16	46	3	16	218	13
16	2	14	16	13	10
2 14 3 2 E 3 $(739)_{10} = (2E3)_{16}$			13 10 13 D A D $(3501)_{10} = (DAD)_{16}$		



Activity-2

a. Convert the following Decimal numbers to Binary

- i. 786.345 ii. 943.095 iii. 6300.586 iv. 4732.7834

b. Convert the following Decimal numbers to Octal

- i. 759 ii. 1256 iii. 9454 iv. 2743

c. Convert the following Decimal to Hexadecimal numbers

- i. 7802 ii. 4923 iii. 3678 iv. 6401

Conversion from Octal to Binary and vice versa

The conversion from Octal to Binary and vice versa is performed by converting each octal digit to its 3-bit binary equivalent. The eight possible digits are converted as follows:

Octal digit	0	1	2	3	4	5	6	7
Binary	000	001	010	011	100	101	110	111

Using these conversions, any octal number can be converted to binary and vice versa.

i. From Octal to Binary

Example: $(7301)_8$ to $(\quad?)_2$

7	3	0	1
↓	↓	↓	↓
111	011	000	001

$(7301)_8 = (111011000001)_2$

ii. From Binary to Octal

Example: $(1100111000101)_2$ to $(\quad?)_8$

- Take group of 3 binaries from the right side.

1100111000101				
1	100	111	000	101

- If any one or two bits are left alone, add zeros to the left to make them group of 3.

001	100	111	000	101
-----	-----	-----	-----	-----

- Convert each binary group to its equivalent Octal digit.

001	100	111	000	101
↓	↓	↓	↓	↓
1	4	7	0	5

$(1100111000101)_2 = (14705)_8$



Activity-3

a. Convert the following Octal numbers to Binary

- i. 765 ii. 1430 iii. 63005 iv. 4232

b. Convert the following Binary numbers to Octal

- i. 10011110 ii. 11000010110 iii. 1000001101 iv. 1110001001101010

Conversion from Hexadecimal to Binary and vice versa

The conversion from Hexadecimal to Binary and vice versa is performed by converting each octal digit to its 4-bit binary equivalent. The eight possible digits are converted as follows:

Hexadecimal	Binary
0	0000
1	0001
2	0010

3	0011
4	0100
5	0101
6	0110
7	0111
8	1000
9	1001
A (10)	1010
B (11)	1011
C (12)	1100
D (13)	1101
E (14)	1110
F (15)	1111

Using these conversions, any Hexadecimal number can be converted to binary and vice versa.

i. From Hexadecimal to Binary

Example: $(D73A1)_H$ to (?)₂

D	7	3	A	1
↓	↓	↓	↓	↓
13	7	3	10	1
1101	0111	0011	1010	0001

$(D73A1)_H$ to $(1101011100110100001)_2$

ii. From Binary to Hexadecimal

Example $(110011100100110101)_2$ to (?)₁₆

- Take group of 4 binaries from the right side.

110011100100110101

11 0011 1001 0011 0101

- If any one or two or three bits are left alone, add zeros to the left to make them group of 4.

0011 0011 1001 0011 0101

- Convert each binary group to its equivalent Hexadecimal digit.

0011	0011	1001	0011	0101
↓	↓	↓	↓	↓
3	3	9	3	5
3	3	9	3	5

$(110011100100110101)_2$ to $(33935)_{16}$



Activity-4

- a. Convert the following Hexadecimal numbers to Binary
 I. AF765 II. D14C0 III. B300E IV. C42F2
- b. Convert the following Binary numbers to Hexadecimal
 I. 1001100001000110 II. 11011100010110 III. 10001100001101
 IV. 111000100000110101110

Conversion from Octal to Hexadecimal and vice versa

i. From Octal to Hexadecimal

Method 1:

- Convert Octal to Decimal number
- Then convert the decimal number to Hexadecimal

Method 2:

- Convert Octal to Binary number
- Then convert the binary number to Hexadecimal

Example: $(6457)_8$ to $(?)_{16}$

Method 1: $(6457)_8 = (3375)_{10}$ { Method is already Explained }
 $(3375)_{10} = (D2F)_{16}$ { Method is already Explained }
 So, $(6457)_8$ to $(D2F)_{16}$

Method 2: $(6457)_8 = (110100101111)_2$ { Method is already Explained }
 $(110100101111)_2 = (D2F)_{16}$ { Method is already Explained }
 So, $(6457)_8$ to $(D2F)_{16}$

ii. From Hexadecimal to Octal

Method 1:

- Convert Hexadecimal to Decimal number
- Then convert the decimal number to Octal

Method 2:

- Convert Hexadecimal to Binary number
- Then convert the binary number to Octal

Example: $(A09D)_{16}$ to $(?)_8$

Method 1: $(A09D)_{16} = (41117)_{10}$ { Method is already Explained }
 $(41117)_{10} = (120235)_8$ { Method is already Explained }
 So, $(A09D)_{16}$ to $(120235)_8$

Method 2: $(A09D)_{16} = (1010000010011101)_2$ { Method is already Explained }
 $(1010000010011101)_2 = (120235)_8$ { Method is already Explained }
 So, $(A09D)_{16}$ to $(120235)_8$



Activity-5

- a. Convert the following Hexadecimal numbers to Octal
 i. AF65 ii. D1C0 iii. B30E iv. C2F2
- b. Convert the following Octal numbers to Hexadecimal
 i. 765 ii. 1430 iii. 63005 iv. 4232

1.2.3 Binary Arithmetic

Computers use binary arithmetic as their fundamental way of performing arithmetic operations because digital electronic circuits inherently operate in binary (base-2) rather than in decimal (base-10) like humans do. In binary arithmetic, there are only two digits: 0 and 1.

Basic Arithmetic Operations: Computers perform addition, subtraction, multiplication, and division in binary just like in decimal, but with binary digits (bits) instead of decimal digits.

Binary Addition:

- Binary addition is performed much like decimal addition, but with only two possible digits: 0 and 1.
- When adding two binary digits (bits), the possible outcomes are:

$$0 + 0 = 0$$

$$0 + 1 = 1$$

$$1 + 0 = 1$$

$$1 + 1 = 10 \text{ (carry 1 to the next higher bit)}$$

Some Examples of Binary Addition:

Example 1: 10010 + 111

$\begin{array}{r} \textcircled{1} \textcircled{1} \text{ (Carry)} \\ 10010 \\ + 111 \\ \hline 11001 \end{array}$	\longrightarrow	18 (Decimal) $+ 7 \text{ (Decimal)}$ 25
--	-------------------	---

Example 2: 11101010 + 10011011

$\begin{array}{r} \textcircled{1} \textcircled{1} \textcircled{1} \textcircled{1} \textcircled{1} \\ 11101010 \\ + 10011011 \\ \hline 110000101 \end{array}$	
--	--

HINT!

To verify your answer you can convert the binary number to decimal and perform decimal arithmetic, like in Example 1 (Addition).

Binary Subtraction:

- Binary subtraction is performed much like decimal subtraction, but with only two possible digits: 0 and 1.
- Borrowing is used when subtracting a larger number from a smaller one.

➤ When subtracting two binary digits (bits), the possible outcomes are:

$$0 - 0 = 0$$

$$1 - 0 = 1$$

$$1 - 1 = 0$$

$$0 - 1 = 1 \text{ with borrowing (borrow 1 from the next higher bit)}$$

Some Examples of Binary Subtraction:

Example 1: $10110 + 101$

$$\begin{array}{r}
 \textcircled{10} \longrightarrow (10)_2 = 2 \\
 \begin{array}{r}
 01 \text{ (Borrow)} \\
 10110 \\
 - 101 \\
 \hline
 10001
 \end{array}
 \end{array}$$

Example 2: $11000101 + 101111$

$$\begin{array}{r}
 \begin{array}{r}
 11110 \\
 0101010 \\
 11000101 \\
 - 101111 \\
 \hline
 10010110
 \end{array}
 \end{array}$$



Activity-6

a. Perform the following Binary Additions

i. $11100001 + 10110001$

ii. $10100111 + 11110101$

iii. $11111101 + 10110111$

iv. $10101011 + 10110001$

b. Perform the following Binary Subtractions

i. $11100001 - 1011001$

ii. $10100111 + 1000101$

iii. $11111101 - 101101$

iv. $10101011 + 10111$

1.2.4 Overflow and Underflow

In computers, overflow and underflow are problems that occur when calculations produce results that are too large or too small to be represented within the allowed number of bits. These conditions are important because they can cause errors in programs and lead to unexpected behavior or bugs. Overflow happens when a value is too large to fit in the available space, while underflow occurs when a value is too small to be represented properly. Understanding these issues is important to prevent problems in software. Overflow is being explained as follows at that level.

Overflow: Overflow happens when a calculation produces a result that is larger than the maximum value that can be stored or represented with the available number of digits or bits in a system. This causes the system to be unable to properly show or handle the result.

Example: 8-bit Unsigned Integer Overflow

An 8-bit unsigned integer can represent values from 0 to 255. If user attempts to add 1 to 255, the result is 256, which cannot be represented with just 8 bits.

$$\begin{array}{r}
 11111111 \text{ (255 in binary)} \\
 + \quad \quad \quad 1 \\
 \hline
 \text{Overflow} \longrightarrow \textcircled{1} 00000000 \\
 10000000 \text{ (256 in binary)}
 \end{array}$$

Since an 8-bit register can only store 8 bits, the ninth bit (1) is the overflow bit, which will be lost and the overall result becomes wrong. This situation can be overcome by introducing 16-bit register.

Handling Overflow and Underflow:

To handle overflow and underflow, programmers can:

- Use Larger Data Types: Switching to a larger data type (e.g., from an 8-bit integer to a 16-bit integer) can help avoid overflow and underflow for larger ranges of values.
- Perform Range Checking: Before performing an arithmetic operation, check if the operation will result in a value outside the representable range and handle it appropriately.
- Use Libraries or Built-in Functions: Some programming languages provide built-in functions or libraries that can detect and handle overflow and underflow conditions.

1.2.5 Compliments (1's and 2's)

Complements:

In digital logic, 'Complements' are used to perform logical operations, especially the subtraction operation. The binary number system contains two types of complements, i.e., 1's complement and 2's complement.

1's Complements

The binary numbers can be easily converted into the 1's complement with the help of a simple technique. According to this algorithm, if we toggle or invert all bits of a binary number, the generated binary number will become the 1's complement of that binary number. That means we have to transform 1 bit into the 0 bit and 0 bit into the 1 bit in the 1's complement.

Example1: 1's complement of binary number 01101

01101	(Number)
10010	(1's Complement)

Example2: 1's complement of binary number 00011101

00011101	(Number)
11100010	(1's Complement)

2's Complements

The binary numbers can be converted into the 2's complement with the help of a very simple technique.

- Take the 1's complement of the binary number
- Add 1 to the LSB (least significant bit)

Example1: 2's complement of binary number 01010001

01010001	(Number)
10101110	(1's Complement)
+ 1	(Adding 1)
10101111	(2's Complement)

So the 2's Complement of 01010001 is 10101111

Example2: 2's complement of binary number 10101110

10101110	(Number)
01010001	(1's Complement)
+ 1	(Adding 1)
01010010	(2's Complement)

So the 2's Complement of 10101110 is 01010010



Activity-7

- a. Convert the following Binary numbers to their 1's Complement forms.
 i. 00111001 ii. 11001100 iii. 11100011 iv. 01010101
- b. Convert the following Binary numbers to their 2's Complement forms.
 i. 01111001 ii. 10001101 iii. 11101011 iv. 01011101

Binary Subtraction using 1's Complement

The following steps are used to perform binary subtraction using 1's Complement.

- Make the number of bits in both minuend and subtrahend the same by adding additional zeros(0s) to left side.
- Convert the subtrahend to the 1's complement.
- Add the 1's complement of the subtrahend with the minuend.
- If the result has a carry, then add that carry in the least significant bit.
- If there is no carry, then take the 1's complement of the resultant to find the answer. In this case the answer will be negative(-ve).

HINT!

You can verify your answer by doing simple subtraction.

Example1: Subtract 100110 from 111000 using 1's complement

- Number of bits are the same.

111000 (Minuend)
 100110 (Subtrahend)

- Convert the subtrahend to the 1's complement.

011001

- Add the 1's complement of the subtrahend with the minuend.

111000
 + 011001

 1 - 010001

- Carry is generated, add it to the LSB of the result

010001
 + 1

 010010

- So the final answer is 010010

Example2: Subtract 10101001 from 11100011 using 1's complement

11100011 (Minuend)
 10101001 (Subtrahend)

- Convert the subtrahend to the 1's complement.

01010110

- Add the 1's complement of the subtrahend with the minuend.

11100011
 + 01010110

 1 - 00111001

- Carry is generated, add it to the LSB of the result

00111001
 + 1

 00111010

- So the final answer is 00111010

Binary Subtraction using 2's Complement

The following steps are used to perform binary subtraction using 2's Complement.

- Make the number of bits in both minuend and subtrahend the same by adding additional zeros(0s) to left side.
- Convert the subtrahend to the 2's complement.
- Add the 2's complement of the subtrahend with the minuend.
- If the result has a carry, ignore it and take the remaining part as answer.
- If there is no carry, then take the 2's complement of the resultant to find the answer. In this case the answer will be negative (-ve).

Example: Subtract 100110 from 111000 using 2's Complement

- Number of bits are the same.

111000 (Minuend)

100110 (Subtrahend)

- Convert the subtrahend to the 2's complement.

011001

+ 1

011010

- Add the 2's complement of the subtrahend with the minuend.

111000

+ 011010

1-010010

- Ignore the Carry and take 010010 as the answer

- So the final answer is 010010



Activity-8

- Convert the following Binary numbers to their 1's Complement forms.
i. 00111001 ii. 11001100 iii. 11100011 iv. 01010101
- Convert the following Binary numbers to their 2's Complement forms.
i. 01111001 ii. 10001101 iii. 11101011 iv. 01011101

PRACTICE TIME!

Subtract 10101001 from 11100011 using 2's complement

1.2.6 Signed and Unsigned Numbers Representation

Binary numbers can be represented in signed and unsigned way. Unsigned binary numbers do not have sign bit, whereas signed binary numbers uses signed bit as well or these can be distinguishable between positive and negative numbers.

Unsigned Numbers Representation:

Unsigned numbers don't have any sign, these can contain only magnitude of the number. So, representation of unsigned binary numbers are all positive numbers only. For example, representation of positive decimal numbers are positive by default. We always assume that there is a positive sign symbol in front of every number. The range of unsigned binary number is from 0 to $(2^n - 1)$, where n is the number of bits. For example in 8-bits form the range will be from 0 to 255 (decimal) and 00000000 to 11111111 (binary)

Example: Represent decimal number 105 in unsigned binary number.

Simply convert 105 into Binary number.

$105 = (01101001)_2$

Signed Numbers Representation:

Signed numbers can represent both positive and negative integers. There are several methods to

represent signed numbers, but the most common one used in modern computers is Two's Complement.

Two's Complement Representation:

To get the 2's complement of a number, flip all the bits and then add 1 to the least significant bit (LSB). We use regular binary for positive numbers and 2's complement for negative numbers.

If the sign bit is 0, the number is positive and we can just use its regular binary form.

If the sign bit is 1, the number is negative, and we need to use the 2's complement of the binary number to get its value.

Example1: Represent -13 in a computer using 8-bit 2's complement.

- Convert 13 to binary: 13 in 8-bit binary form is 00001101
- Invert all the bits: 111100101
- Add 1 to get 2's complement: $11110010+1=11110011$
- So, -13 is represented as 11110011 using 2's Complement

Example2: Represent -55 in a computer using 8-bit 2's complement.

- Convert 55 to binary: 55 in 8-bit binary form is 00110111
- Invert all the bits: 11001000
- Add 1 to get 2's complement: $11001000+1=11001001$
- So, -55 is represented as 11001001 using 2's Complement



Activity-9

Represent the following numbers using 8-bit 2's complement.

i. -90

ii. -122

iii. -150

iv. -200

v. -240

Floating-point Numbers Representation:

Floating point numbers are a way to represent real numbers that can have fractional parts. They are used in computers to handle very large and very small numbers efficiently, as well as to perform arithmetic operations on them.

Representation of Floating Point Numbers:

Floating point numbers are represented in a computer using a standard format defined by the IEEE (Institute of Electrical and Electronics Engineers). The most common format is IEEE 754, which specifies how floating point numbers should be stored in binary.

Components of a Floating Point Number

A floating point number in the IEEE 754 format is divided into three parts:

Sign Bit: Indicates whether the number is positive or negative.

Exponent: Represents the power of 2 by which the fraction (or mantissa) is multiplied.

Mantissa (or Significand): Represents the significant digits of the number.

For example, in a 32-bit (single precision) floating point representation is shown in Figure.

- 1 bit for the sign
- 8 bits for the exponent
- 23 bits for the mantissa

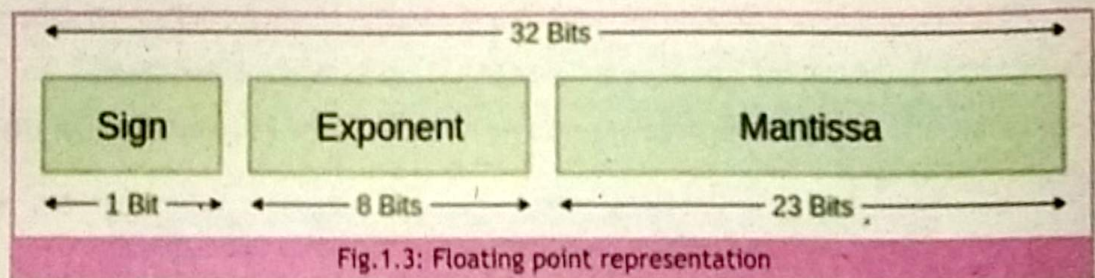

Fig.1.3: Floating point representation

Note: Further details about how floating point numbers are represented are beyond the scope of grade 10 students.

1.3 Common Coding Schemes (ASCII and Unicode)

Coding schemes are standards that computers use to convert and represent data in a format that they can understand, such as binary digits (1's and 0's). Since computers cannot interpret human-readable characters like letters, numbers, and symbols directly, they need to translate this data into a machine-readable format. Different coding schemes are used for this purpose, among which ASCII and Unicode are common.

Why Coding Schemes are used

Data Representation: Computers use binary (0s and 1s) to represent all data. Coding schemes map human-readable characters to binary codes, making it possible for computers to store and manipulate text and other data.

Standardization: Coding schemes provide a consistent way to represent characters across different platforms and devices, ensuring compatibility and accurate data exchange.

Efficiency: They optimize the storage and processing of data by providing a fixed-length representation for each character.

Communication: They enable different computer systems to communicate with each other using a common representation for characters and symbols.

ASCII Coding Scheme

ASCII stands for American Standard Code for Information Interchange. It is a standard data coding scheme in computers. It assigns standard numeric values to alphabets, numerals, punctuation marks and other characters used in computers. Before ASCII was developed, different manufacturers' models of computers could not communicate with one another. Each computer manufacturer represented alphabets, numerals and other characters in its own way.

On June 17, 1963 ASCII was approved as the American standard code. However, it did not have wide acceptance because IBM chose to use EBCDIC (Extended binary coded decimal interchange code).

code) in its computers. Initially ASCII used 7-bit codes of various combinations of 0's and 1's to represent 128 different characters ($2^7 = 128$). ASCII-7 could not represent newly developed characters so it underwent further developments and revisions and ASCII-8 was developed.

Extended ASCII Code (ASCII-8 bit Code):

ASCII was extended to an 8-bit code that can represent ($2^8 = 256$) different characters. ASCII-8 became popular in 1981 when it was used first time in IBM's Personal Computer (PC) and soon it became industry standard for personal computers. Many Windows systems use an 8-bit ASCII encoding and this Microsoft specific encoding is known as ANSI code. ANSI stands for American National Standards Institute. In extended ASCII-8, 32 code combinations are used for machine and control commands, such as "start of text," "carriage return," and "form feed", etc. Control commands do not represent printable information, but rather they help control devices, such as printers. Table 1 (Annexure 1) shows non-printable ASCII control codes. Table 2 (Annexure 2) shows printable ASCII characters and Table 3 (Annexure 3) shows extended ASCII printable characters.

Just to Remember!

Characters	ASCII-8 Value in Decimal
0-9	48-57
A-Z	65-90
a-z	97-122

Unicode Coding Scheme

Even extended ASCII (ASCII-8) does not include enough code combinations to support all written languages. Asian languages, for instance, require thousands of characters. This limitation gave rise to new encoding standard known as **Unicode (Universal coding system)** that can support all the written languages. It was published by Unicode Consortium (a group of multilingual software manufacturers). The first version of Unicode was introduced in 1991.

Unicode is an international character-encoding system designed to facilitate the electronic exchange, processing, and display of written texts from diverse modern and classical languages. The Unicode Standard encompasses letters, digits, accents, punctuation marks, technical symbols for the world's major written languages, as well as emoji and other symbols, all using a uniform encoding scheme. The latest version of Unicode includes over 100,000 characters. Unicode assigns a unique number to each character that remains consistent across all systems that support Unicode.

Unicode defines multiple encodings of its single character set: UTF-7, UTF-8, UTF-16, and UTF-32. UTF stands for Unicode Transformation Format. Conversion of data among these encodings is lossless, means do not lose the quality. Unicode was originally a 2-byte (16-bits) character set. Unicode version 3, however, is a 4-byte (32-bits) code and is fully compatible with ASCII. These all support encoding the same set of characters. Table 4 (Annexure 4) shows a part of Unicode character set after ASCII-8.

1.4 Operating System

An operating system (OS) is essential software that manages a computer's memory, processes, hardware, and software, enabling user interaction. It loads into RAM when the computer is turned on and is necessary to run any programs. OS has evolved since the first computer generation and is present in all devices like desktops, tablets, and smartphones, with common examples being Windows, Mac OS, Linux, iOS, and Android.

1.4.1 Main Tasks/Functions of an Operating System

Operating system performs the following main tasks or functions.

- Process Management
- Memory Management
- File Management
- Device Management
- Network Management
- Security management

Process Management

A process is a program in execution, and process management in an operating system allocates resources like CPU time to various processes in memory. For example, with three processes (A, B, and C), each having different CPU cycles (A = 5 ms, B = 2 ms, C = 1 ms), the OS manages execution times. In Case 1 (ABC order), the total time is 6.67 ms, while in Case 2 (BCA order), it's 4.33 ms, showing that Case 2 is more efficient.

Memory Management

Memory management is the part of operating system that controls and manages the operation of main memory during the operation of computer. It allocates space to programs that are loaded in main memory for execution. It keeps track of freed memory when a program is closed and updates the memory status.

Example: In this example the OS is

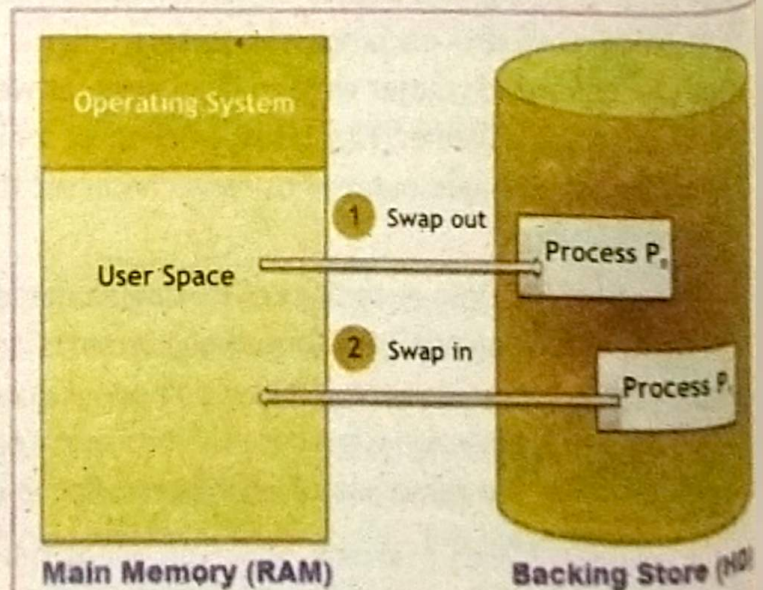
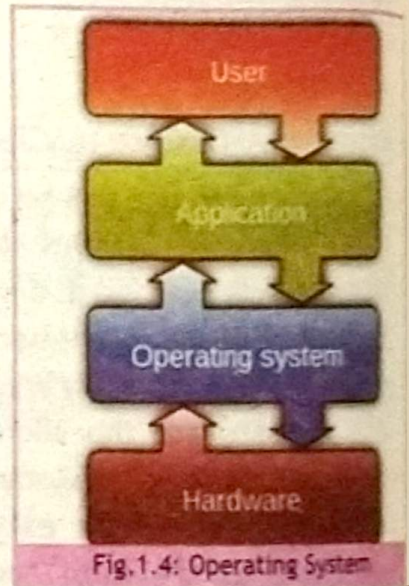

Fig.1.5: Memory Management

managing memory for two processes P0 and P1. P1 is being loaded (swap in) and P0 is being taken out (swap out) from the main memory (RAM). The whole process is shown in Fig 1.5.

File Management

File management is the part of operating system that manages files and folders on storage devices such as hard disk, USB flash drive and DVD. It allows computer user to perform operations such as creating, copying, moving, renaming, deleting, and searching files and folders. It also allows the user to perform read, write, open and close operations on files and folders. Fig 1.6 shows the management of files in various folders by OS.

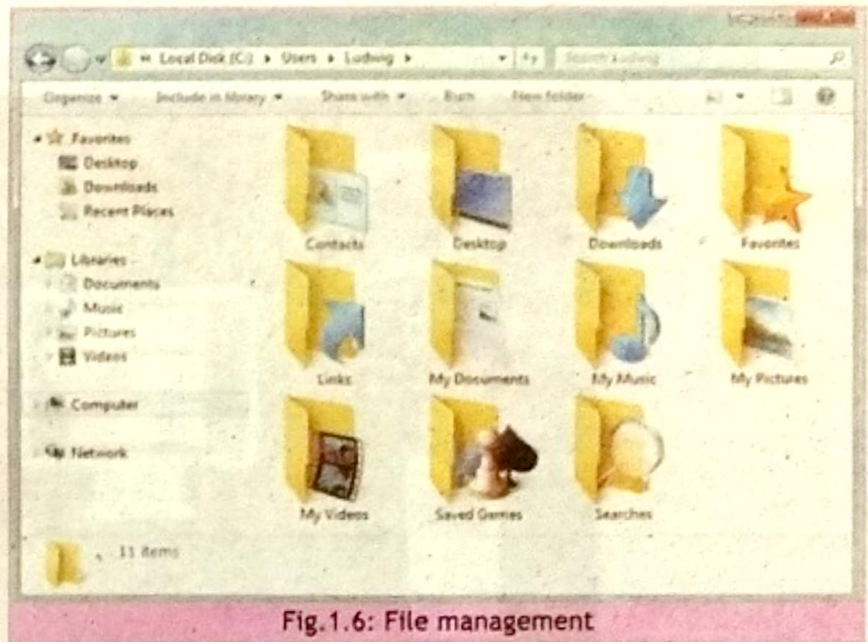

Fig.1.6: File management

Device Management

Device management is the part of operating system that controls input and output devices, such as keyboards, mouse, printers, and network interfaces. Efficient I/O management improves the performance of the computer. As shown in Fig. 1.7.

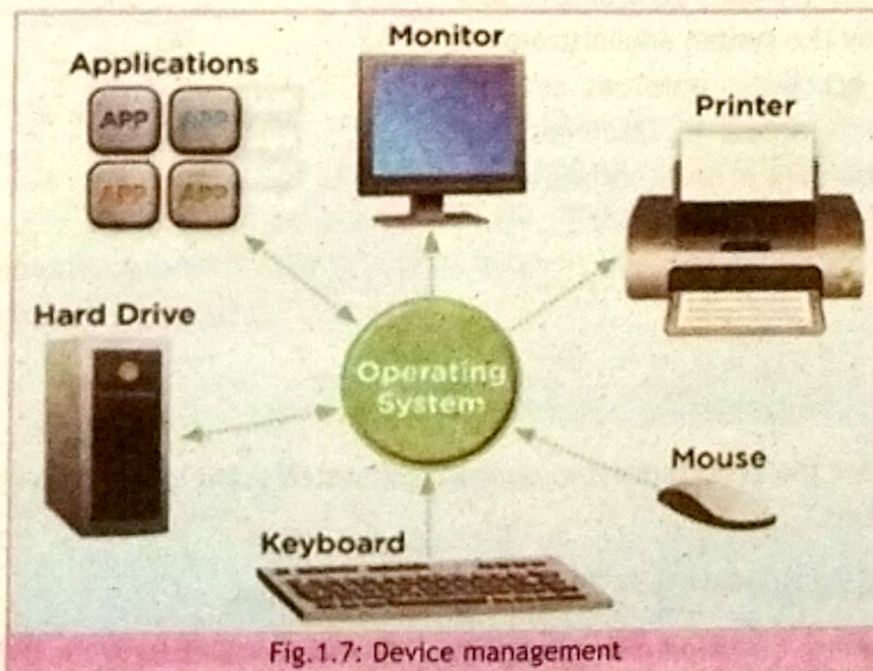

Fig.1.7: Device management

Example: There are three programs A, B and C which are using the printer. Now the OS will decide which program to use the printer first. A queue will be set by the OS and each program will get the printer by its turn.

Network Management

Network management is the part of network operating system that monitors and manages the resources of a network. It allows to create user groups and assigns privileges to them. It shares the network resources among users and detects and fixes network problems.

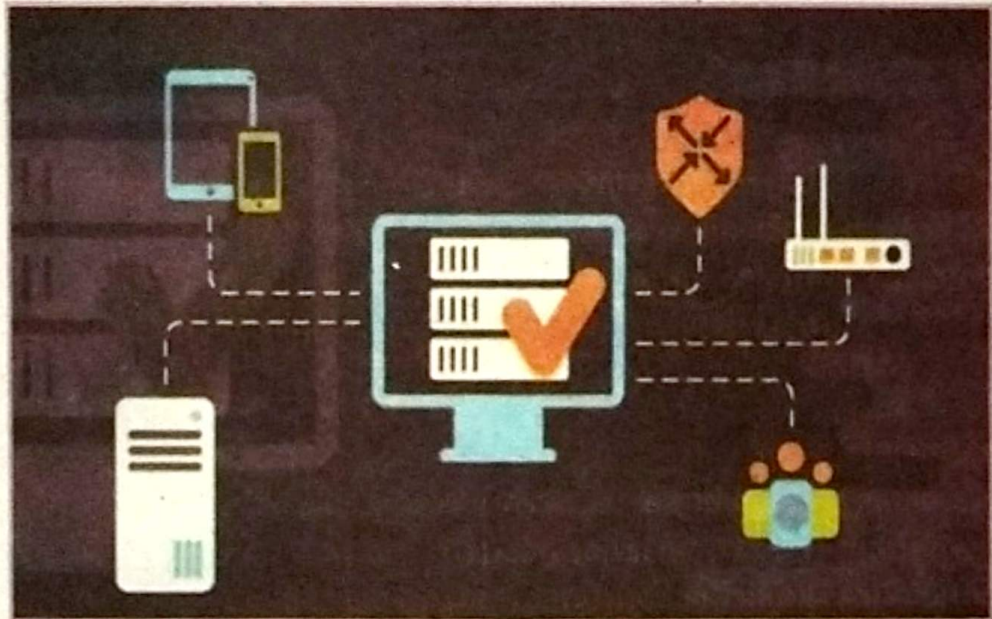

Fig.1.8: Network management

Security management

Security management in an operating system ensures resources are used according to user privileges set by the system administrator. It creates user accounts, enforces security policies, controls access to resources, and protects the system from unauthorized access and malware.

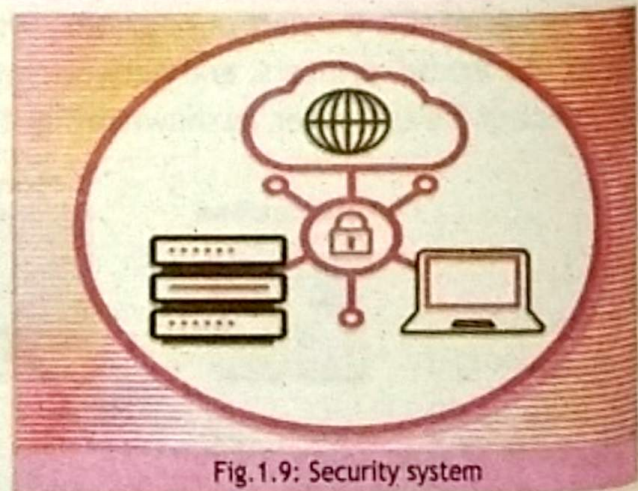

Fig.1.9: Security system

1.4.2 Types of Operating Systems

The following are the important types of operating systems that are commonly used on various computer systems.

Batch Processing Operating System

A batch processing operating system groups similar tasks into batches and executes them sequentially. It is ideal for repetitive tasks, such as payroll processing or generating bank statements, where the same operation is applied to multiple users or jobs. While this system provides efficiency in handling large volumes of similar tasks, it may introduce delays as jobs are processed one after another.

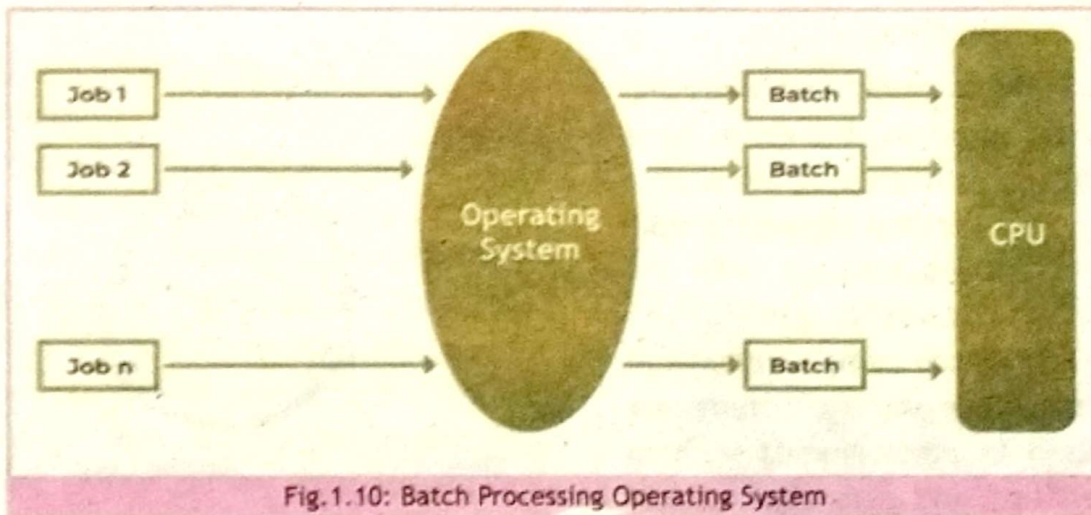

Fig. 1.10: Batch Processing Operating System.

Multiprogramming Operating System (RTOS)

A multiprogramming operating system allows multiple programs to be loaded into the main memory simultaneously. Although the CPU can execute only one program at a time, it switches between programs when one is waiting for input or output, thus maximizing CPU utilization. This system is designed to improve the efficiency of the computer by ensuring that the CPU is rarely idle.

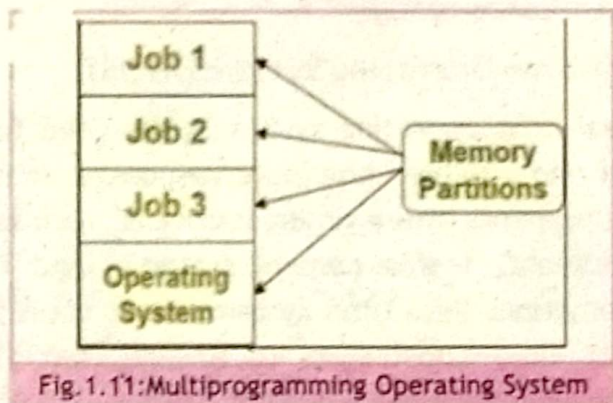

Fig. 1.11: Multiprogramming Operating System

Multitasking Operating System

A multitasking operating system enables multiple tasks to be performed concurrently on a single CPU. The system rapidly switches between tasks, creating the impression that all tasks are running simultaneously. This capability is essential for modern personal computers and mobile devices, where users often run several programs at once.

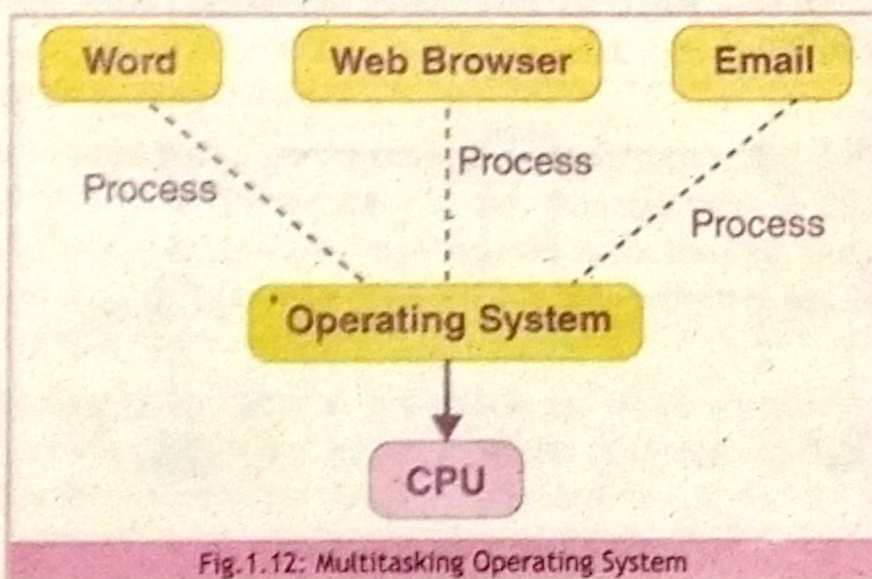

Fig. 1.12: Multitasking Operating System

Time-sharing Operating System

A time-sharing operating system divides CPU time into short intervals, known as time slices, and allocates each program a time slice in turn. This method allows multiple users or programs to interact with the system simultaneously, giving the appearance that all are being processed at the same time. Time-sharing systems are commonly used in environments such as banks, universities, and large organizations that require multiple users to access the system concurrently.

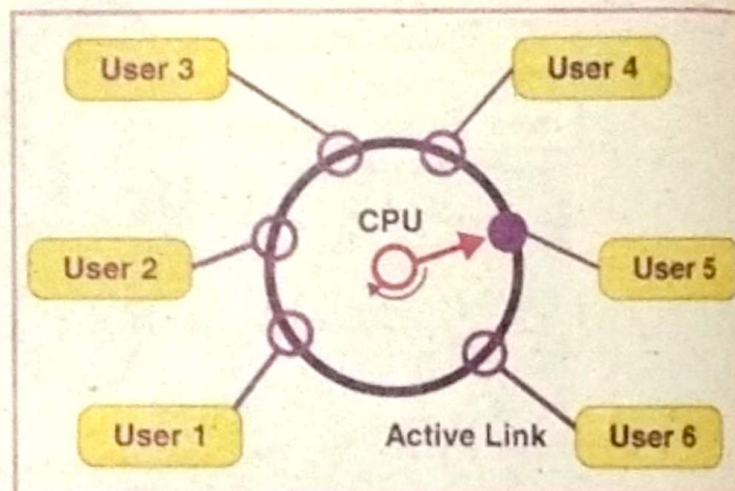

Fig.1.13: Time-sharing Operating System

Real-time Operating System (RTOS)

A real-time operating system is designed to process data and provide immediate responses. It is used in environments where timing is critical, such as medical equipment, traffic control systems, and industrial automation. Real-time systems must operate within strict time constraints to ensure that tasks are completed within a specified deadline, making them highly reliable and responsive.

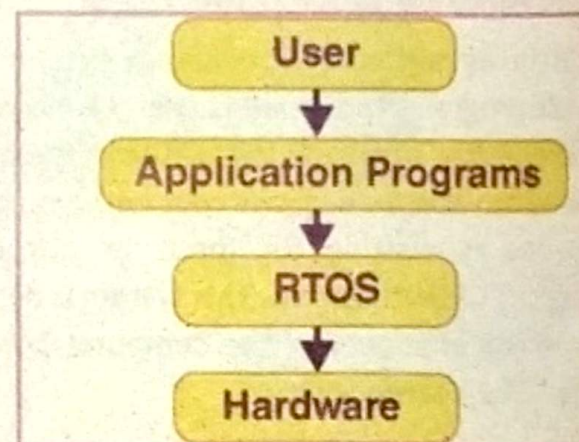

Fig.1.14: Real-time Operating System

Multiprocessor Operating System

A multiprocessor operating system controls the operation of multiple CPUs within a single computer system. By distributing tasks among several processors, the system can handle large amounts of data more efficiently and increase the overall processing speed. Multiprocessor systems are used in environments requiring high performance, such as data centers, servers, and scientific research applications.

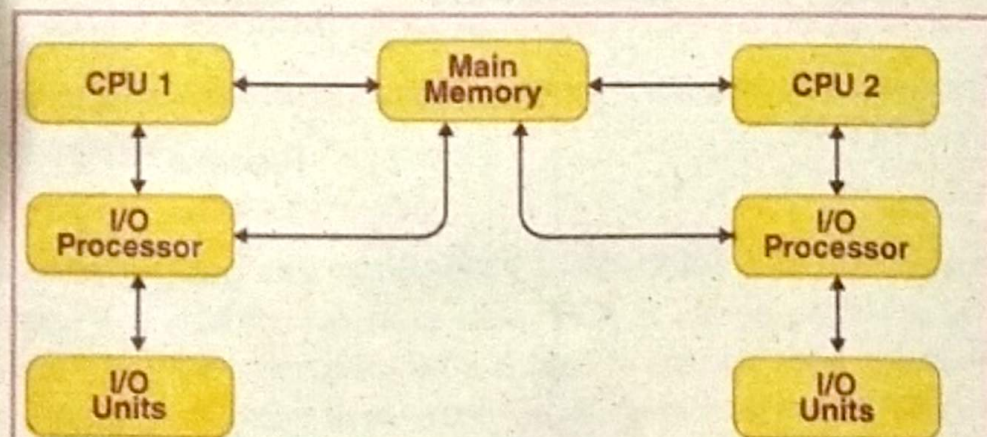

Fig.1.15 Multitasking Operating System

Distributed Operating System

A distributed operating system manages a network of computers, allowing programs to run on multiple machines simultaneously. In a distributed system, the operating system distributes tasks across different computers in the network, balancing the load and providing fast execution of application software. Users do not need to know which machine is processing their tasks, as the distributed OS manages this transparently. This system is widely used in cloud computing and other networked environments.

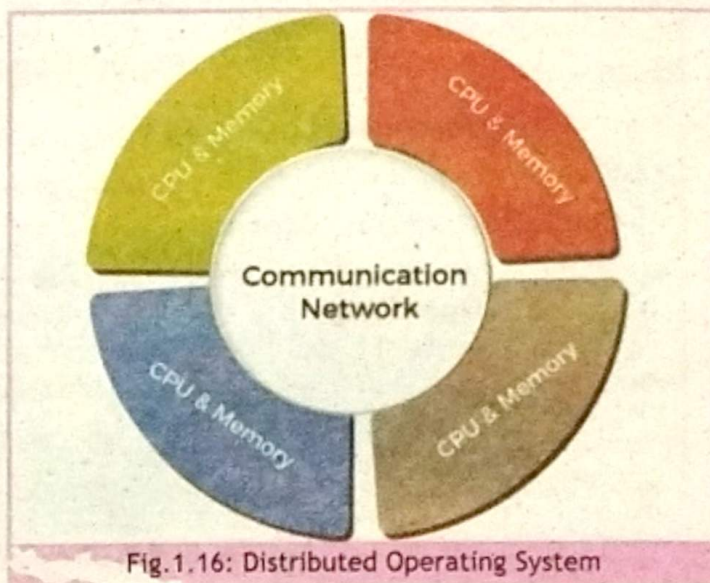

Fig. 1.16: Distributed Operating System

Embedded Operating System

An embedded operating system is integrated into the hardware of a specific device, such as a microwave oven, TV, or camera. It is designed to perform specialized tasks and operates automatically when the device is turned on. Embedded operating systems are optimized for the specific functions of the device and provide reliable performance with minimal resource requirements. They are commonly used in consumer electronics and industrial machines.

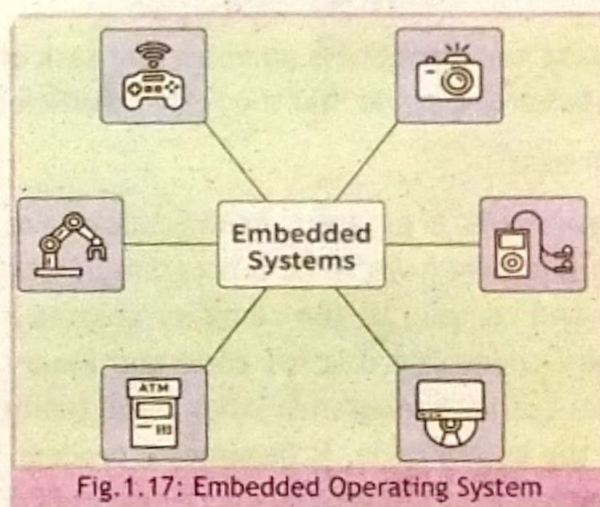

Fig. 1.17: Embedded Operating System

1.4.3. How OS manages to run Applications?

Application programs run on top of operating systems by utilizing the resources and services provided by the operating system. The operating system serves as an intermediary between the hardware and the application programs, managing tasks such as memory allocation, process scheduling, and device management.

For example, when a user opens a word processing program such as Microsoft Word, the operating system allocates memory for the program to run, manages input/output operations such as reading and writing files, and schedules the program to run on the CPU. The operating system also provides access to system resources such as printers and network connections that the application program may need to use.

Overall, the operating system acts as a platform on which application programs can run, providing a layer of abstraction that allows programs to interact with the hardware without needing to know the specific details of the underlying hardware. As shown in Fig 1.18.

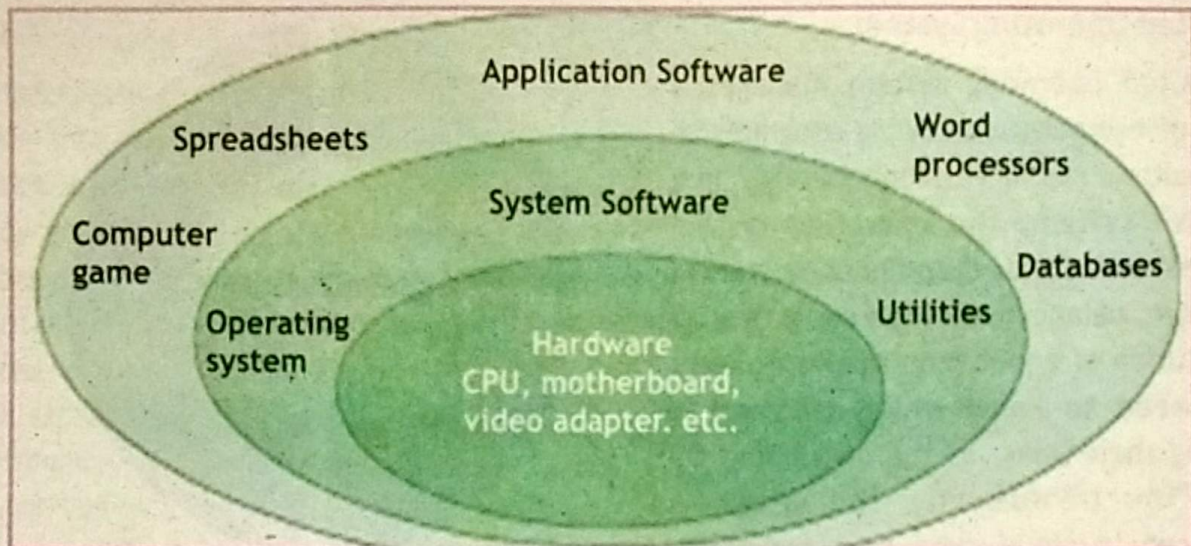

Fig. 1.18: Application and System software

1.4.4 Process Management

Process management is an important task of operating system. It allocates systems resources to various processes so that they can run efficiently.

Process:

A process is a program in execution. For example, when we write a program in C or C++ and compile it, the compiler creates a binary code. The original code and Binary code, both are programs. When we actually run the binary code, it becomes a process. Process is a part of program under execution that is scheduled and controlled by

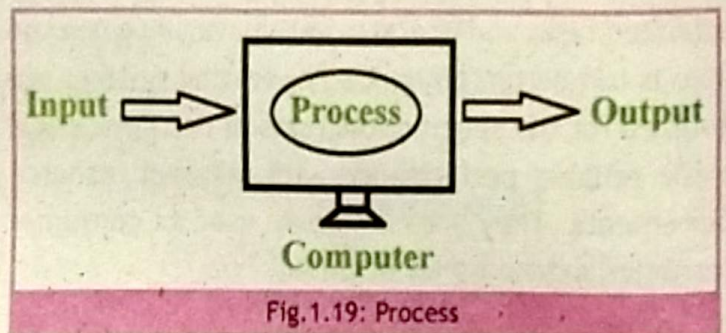

Fig. 1.19: Process

operating system. When a program is loaded in memory for execution, it becomes a process. A program is an executable code that is stored in disk as a text file whereas a process is a dynamic instance of a program during its execution in RAM. It represents basic unit of work. It uses various resources of computer such as CPU time, files, I/O devices, memory, etc.

Various States of a Process:

There are five states of a process which are start, ready, running, waiting and terminated as shown in Figure.

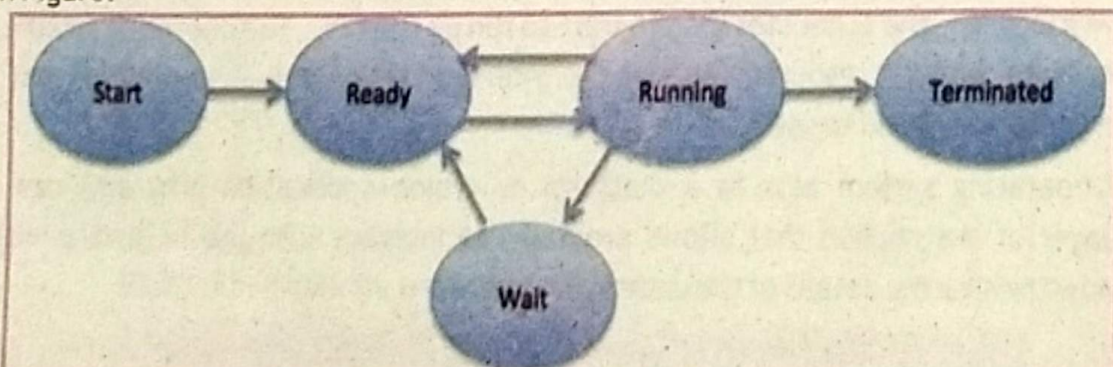

Fig. 1.20: Various States of a Process

Start/New State: This is the first state of a process when it is created. Any new operation or service that is requested by a program for execution by the processor is known as new state of process.

Ready State: A process is said to be in ready state when it is ready for execution but it is waiting to be assigned to the processor by the operating system.

Running State: A process is said to be in running state when it is being executed by the processor. A process is assigned to a processor for execution by operating system.

Blocked State/Waiting State: A process is in blocked or waiting state when it is not under execution. It is waiting for a resource to become available.

Terminated State: A process is in terminated state when it completes its execution.

Thread and Process:

In programming, there are two basic units of execution: processes and threads. They both execute a series of instructions. A Process is an instance of a program that is being executed. A process may be made up of multiple threads. A Thread is a basic ordered sequence of instructions within a process that cannot be executed independently. The threads are made of and exist within a process; every process has at least one thread. Multiple threads can also exist in a process and share resources.

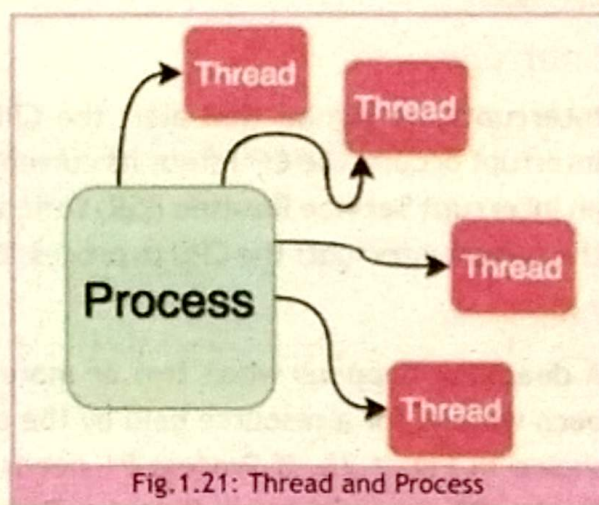

Fig.1.21: Thread and Process

Comparison between Process and Thread

	Process	Thread
1	An executing instance of a program is called a process.	A thread is a subset of the process.
2	It has its own copy of the data segment of the parent process.	It has direct access to the data segment of its process.
3	Any change in the process does not affect other processes.	Any change in the thread may affect the behavior of the other threads of the process.
4	Processes run in separate memory spaces.	Threads run in shared memory spaces.
5	Process is controlled by the operating system.	Threads are controlled by programmer in a program.
6	Processes are independent.	Threads are dependent.

Process Scheduler:

A process scheduler is part of the operating system that manages the execution order of processes by the CPU. It ensures efficient and fair use of CPU time by allocating processing time based on specific scheduling algorithms.

Process Synchronization:

Process synchronization is a method used to coordinate multiple processes or threads that share resources. It prevents issues like **race conditions**, which occur when processes try to access the same memory at the same time. The operating system controls the execution order to avoid conflicts.

Interrupts:

Interrupts are signals that alert the CPU to events that need immediate attention. When an interrupt occurs, the CPU stops its current task, saves its state, and runs a special program called an **Interrupt Service Routine (ISR)** to handle the event. For example, when you receive an email, the system interrupts the CPU to process the email quickly.

Deadlock:

A **deadlock** happens when two or more processes are stuck, each waiting for a resource held by the other. For example, as shown in Fig. 1.23, if Process P1 needs Resource R2 held by Process P2, while P2 needs Resource R1 held by P1, neither can proceed. The operating system must detect and resolve these deadlocks to keep processes running smoothly.

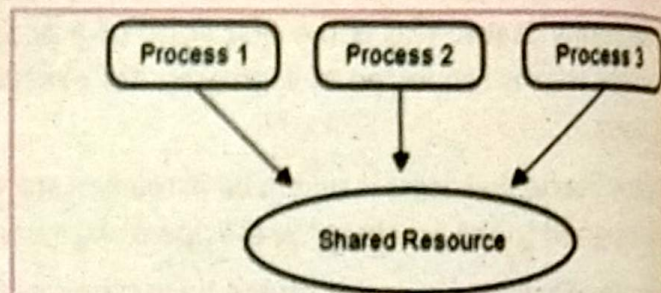

Fig.1.22: Process Synchronization

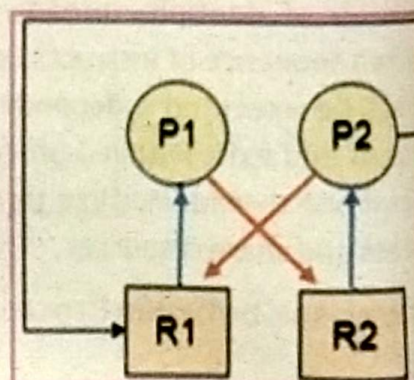

Fig.1.23: Deadlock

1.4.5. Computer System Resources managed by an Operating System

The four main computer system resources managed by an operating system are:

CPU (Central Processing Unit) Management:

The operating system manages the CPU by scheduling processes, ensuring efficient utilization of the CPU, and prioritizing tasks. This involves process scheduling algorithms, deadlock resolution, and handling interrupts.

Memory Management:

The operating system is responsible for managing the system's memory, which includes RAM. This involves allocation and deallocation of memory spaces to various programs, managing memory hierarchy, and ensuring that each process has adequate memory while optimizing the use of available memory.

Storage Management:

The operating system manages data storage, including hard drives, SSDs, and other storage devices.

devices. This involves file system management, managing read/write operations, ensuring data integrity, and providing an interface for file and directory management.

I/O (Input/Output) Management:

The operating system manages input and output devices such as keyboards, mice, printers, and network interfaces. This includes managing device communication, buffering, and handling device drivers to ensure that the I/O operations are carried out smoothly and efficiently.

1.4.6 The Structure and Organization of the File System

The file system is a critical component of an operating system, responsible for organizing, storing, retrieving, and managing data on storage devices like hard drives, SSDs, and USB drives. Here's a detailed explanation of the structure and organization of a file system:

File System Components

A file system is composed of several key components:

Files: The smallest unit of data storage, representing a collection of bytes stored on a disk. Files can be of various types, such as text files, executables, images, etc.

Directories/Folders: Also known as folders, directories are containers that hold files and other directories, providing a hierarchical structure.

Metadata: Information about files and directories, such as their names, sizes, types, permissions, and timestamps (creation, modification, and access times).

Directory/Folder Structure

The directory/folder structure can be organized in different ways, commonly used directory/folder structures are shown in Fig. 1.24.

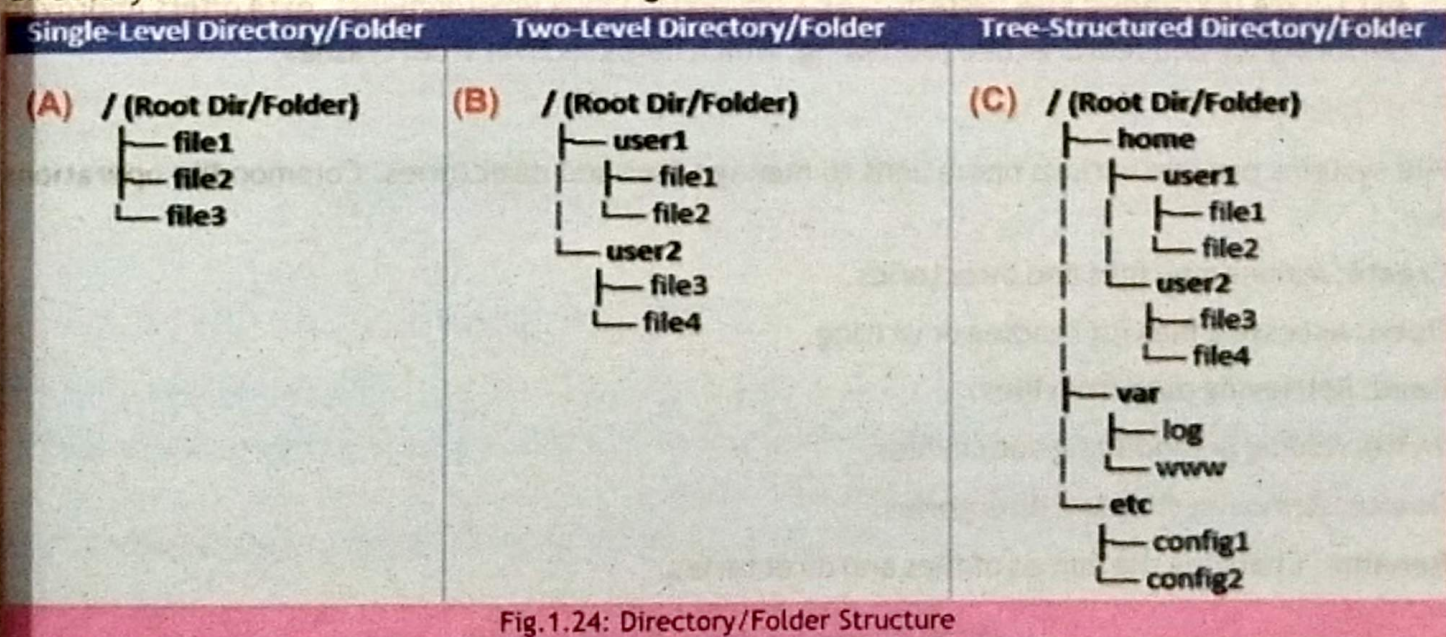

Fig.1.24: Directory/Folder Structure

Single-Level Directory/Folder: All files are contained in a single directory/folder. This structure is simple but becomes inefficient as the number of files grows. Figure A shows single level directory/folder structure.

Two-Level Directory/Folder: Each user has their own directory under the root directory, solving some of the limitations of the single-level structure. Figure B shows two level directory/folder structure.

Tree-Structured Directory/Folder: The most common structure, allowing a hierarchy of directories and subdirectories, resembling a tree. This structure is flexible and scalable. Figure C shows tree-structured directory/folder structure.

File Allocation Methods

Files can be stored in different ways:

- **Contiguous Allocation:** Files occupy consecutive blocks, which speeds up access but can cause fragmentation.
- **Linked Allocation:** Files are stored in linked lists, allowing flexibility but possibly slower access due to pointer traversal.
- **Indexed Allocation:** Uses an index to point to the actual data blocks, allowing faster access while balancing storage efficiency.

File System Types

Various file systems are designed to meet different needs and have unique features. Some common file systems include:

- **FAT (File Allocation Table):** An older file system used by DOS and Windows. Simple but limited in features and scalability.
- **NTFS (New Technology File System):** Used by Windows NT and later versions. Supports large files, security features, and disk quotas.
- **ext3/ext4 (Extended File System 3/4):** Common in Linux environments. ext4 offers improved performance and features like journaling, which helps recover from crashes.

File Operations

File systems provide various operations to manage files and directories. Common file operations are:

Create: Making new files and directories.

Open: Accessing files for reading or writing.

Read: Retrieving data from files.

Write: Adding or modifying data in files.

Delete: Removing files and directories.

Rename: Changing the names of files and directories.

1.5 Computer Software

Computer software, often referred to simply as "software," is a collection of programs, data, and instructions that tell a computer how to perform specific tasks or functions. It is an important component of any computer system, enabling it to process data, run applications, and interact

with users. Software is typically categorized into the following main types:

- System Software
- Application Software
- Programming software
- Driver software

1.5.1 Comparing Different Software Types

Software Type	Purpose & Function	Examples
System Software	<ul style="list-style-type: none">➤ Manages hardware and system resources.➤ Controls overall system operations and provides a platform for applications to run.➤ Essential for the computer's overall functioning.	Windows, macOS, Linux, Android
Programming Software	<ul style="list-style-type: none">➤ Provides tools for writing, testing, and debugging code.➤ Translates programming languages into machine-readable code, helping developers create software.	Eclipse for Java, Coda for Mac, Visual Studio for multiple languages, GitHub for source code
Application Software	<ul style="list-style-type: none">➤ Performs specific tasks for the user, like writing, streaming, or browsing.➤ Designed to meet user needs for specific activities.	Microsoft Word, Spotify, Google Chrome
Driver Software	<ul style="list-style-type: none">➤ Acts as a bridge between the operating system and hardware devices.➤ Ensures proper communication and functionality between the system and external devices.	Printer drivers, NVIDIA graphics drivers, Wi-Fi drivers

1.5.2 Offline and Online Applications

Offline Applications

Offline applications are programs that can run without an internet connection. They rely entirely on the device's local resources, such as storage and processing power, to function. These apps are useful when there's no access to the internet, but they can still perform tasks.

Examples:

- **Microsoft Word** - used for writing and editing documents.
- **Adobe Photoshop** - used for image editing and graphic design.
- **VLC Media Player** - plays media files like videos and music stored locally on the device.

Online Applications

Online applications require an internet connection to function because they access resources, data, or services hosted on remote servers. These apps often provide real-time data and collaborative features.

Examples:

- Google Docs - for creating and sharing documents in real-time.
- Spotify - for streaming music.
- Gmail - for sending and receiving emails.

1.5.3 Uses of Common Productivity Application Software

Software Type	Examples	Uses
Word Processors	Microsoft Word, Google Docs	Writing essays, reports, letters, resumes, and professional documents.
Spreadsheets	Microsoft Excel, Google Sheets	Budgeting, financial analysis, tracking inventory, data charts.
Presentation Software	Microsoft PowerPoint, Google Slides	Business presentations, educational lectures, and project proposals.
Database Management Systems (DBMS)	Microsoft Access, MySQL	Managing customer data, inventory, employee records, and large datasets.
Email Clients	Microsoft Outlook, Mozilla Thunderbird	Organizing emails, scheduling appointments, managing contacts.
Note-Taking Applications	Evernote, Microsoft OneNote	Keeping track of tasks, lecture notes, organizing projects and ideas.
Calendar/Task Management	Google Calendar, Microsoft To-Do	Managing time, setting reminders, planning meetings, tracking tasks.
PDF Editors	Adobe Acrobat, Foxit Reader	Editing PDFs, signing documents, converting documents to/from PDF.
Graphic Design Software	Adobe Photoshop, Canva	Designing posters, flyers, social media content, and marketing materials.
Graphic Design Software	Microsoft Project, Trello	Organizing tasks, tracking project timelines, team collaboration.
Video Conferencing Tools	Zoom, Microsoft Teams	Conducting meetings, webinars, virtual classrooms, and online collaboration.

1.5.4 Application Patch

An application patch is a piece of software designed to update, fix, or improve an existing program or its supporting data. Patches address issues such as security vulnerabilities, bugs, or performance problems and can also add new features or functionalities to the application.

Key Functions of Application Patches:

Fix bugs: Resolve software glitches or errors.

Improve security: Patch vulnerabilities to prevent attacks.

Enhance performance: Optimize the program to run more smoothly.

Add features: Introduce new functionalities or improvements to the existing software.

Examples:

Security Patch for Windows: Microsoft regularly releases security patches to fix vulnerabilities in its operating systems to prevent malware attacks.

Game Updates: Games like World of Warcraft and Call of Duty often release patches that fix bugs, balance gameplay, and add new content.

Adobe Acrobat Patch: Adobe frequently provides patches to fix issues or add security updates to its PDF editing software.

1.5.5 Software Hosting

Software hosting refers to the process of deploying, managing, and providing access to software applications on servers. These servers can be located on-premises, in data centers, or in the cloud. The primary objective of software hosting is to make applications accessible to users over a network, typically the internet.

Some common types of Software Hosting are:

On-Premises Hosting: On-premises hosting involves installing and running software on servers located

within an organization's physical premises. This setup offers complete control over the hardware, software, and data security, making it ideal for organizations with strict compliance and security requirements. However, it comes with high upfront costs for purchasing and setting up the hardware, as well as ongoing maintenance and operational expenses. As shown in Fig. 1.25.

Pros:

- You have complete control over hardware and data security.
- It is customizable to specific needs and compliance requirements.

Cons:

- It has high initial and ongoing costs.

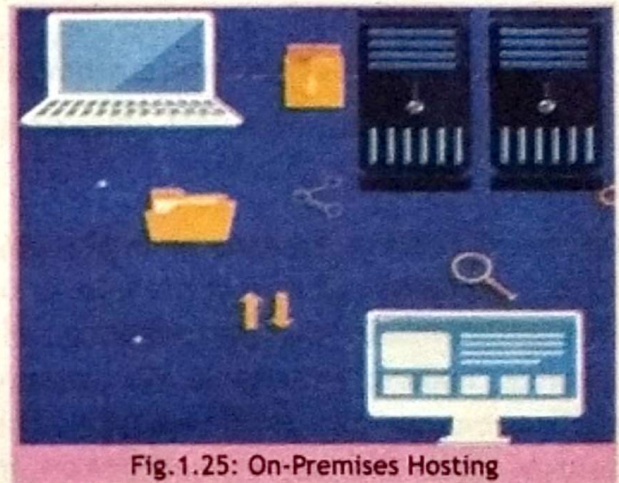

Fig.1.25: On-Premises Hosting

- It requires in-house technical expertise. It has limited scalability.

Shared Hosting:

Shared hosting involves multiple websites or applications sharing the same server resources provided by a hosting company. This is a cost-effective solution, making it suitable for small websites and applications with moderate traffic. The hosting provider handles server maintenance, updates, and security. However, shared resources can lead to performance issues, and there are potential security risks due to neighboring sites on the same server. As shown in Fig. 1.26.



Fig. 1.26: Shared hosting

Pros:

- It is cost-effective.
- It is easy to set up and manage.

Cons:

- You have limited control and customization. There are potential performance issues.
- There are security risks from other sites on the server.

Dedicated Hosting:

Dedicated hosting provides an entire physical server for the exclusive use of a single user or organization. This setup ensures high performance, reliability, and security, making it suitable for resource-intensive applications and high-traffic websites. Users have full control over the server configuration. However, dedicated hosting is costly and requires significant technical expertise for server management and maintenance. As shown in Fig. 1.27.



Fig. 1.27: Dedicated Hosting

Pros:

- It provides high performance and reliability.
- You have complete control over server configuration.
- It offers enhanced security.

Cons:

- It has a high cost.
- It requires technical expertise for management.

Cloud Hosting:

Cloud hosting uses a network of virtual and physical servers to provide scalable and flexible resources on demand. Managed by cloud providers like AWS, Google Cloud, and Microsoft Azure, it offers high scalability, cost-efficiency with a pay-as-you-go model, and excellent reliability. Cloud hosting is ideal for applications with variable or unpredictable traffic. However, it depends on internet connectivity, and there may be concerns over data security and compliance. As shown in Fig. 1.28.

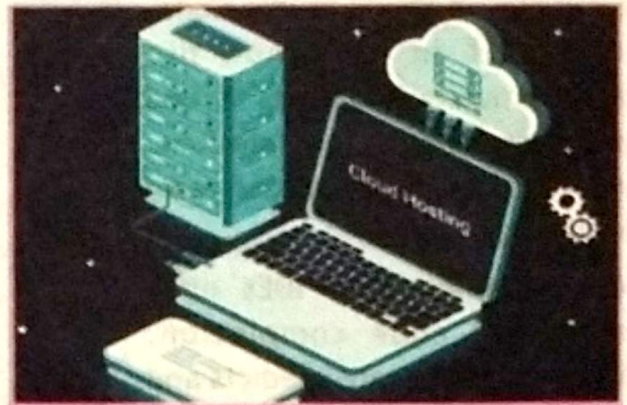

Fig. 1.28: Cloud Hosting

Pros:

It is highly scalable and flexible.

It is cost-efficient with pay-as-you-go pricing. It is reliable and supports global reach.

Cons:

- It is dependent on internet connectivity.
- There are potential data security and compliance concerns.

1.5.6 Programming Software

Programming software, often referred to as Integrated Development Environments (IDEs), text editors, and compilers, helps programmers write, debug, and compile code efficiently. The following is a detailed explanation of how these tools assist programmers in the coding and compilation process.

Components of Programming Software:

Text Editors: Text editors are basic tools that allow programmers to write and edit code. Examples include Notepad++, Sublime Text, and Visual Studio Code.

Integrated Development Environments (IDEs): IDEs are comprehensive tools that combine a text editor, debugger, and compiler in one interface. Examples include IntelliJ IDEA, Eclipse, and Visual Studio.

Compilers: Compilers translate code written in a high-level programming language into machine code that the computer can execute. Examples include GCC (GNU Compiler Collection) for C/C++ and javac for Java.

How Programming Software Helps:

Writing Code: Text Editors and IDEs provide a platform for writing code with features like syntax highlighting, which colors the code according to its syntax, making it easier to read and understand. For example, keywords in a programming language might appear in blue, while comments are in green.

Example: In Visual Studio Code, typing `if` in a Python file automatically highlights it and suggests possible completions, making coding faster and reducing errors.

Code Completion: IDEs offer advanced code completion, where the software predicts and suggests the next part of the code you are typing. This feature helps in writing code faster and with fewer errors.

Debugging: IDEs come with integrated debuggers that allow programmers to run their code step-by-step, inspect variables, and understand the flow of execution to find and fix bugs (errors). Fig.1.29 shows Python programming language IDE.

Error Checking and Syntax Highlighting:

Text Editors and IDEs provide real-time error checking, underlining syntax errors and other issues as you type. This immediate feedback helps in quickly identifying and correcting mistakes. Fig 1.30 shows syntax error in a program.

Example: In Visual Studio Code, if you forget a semicolon in a JavaScript file, it highlights the error and provides suggestions for fixing it.

Compiling Code: Compilers take the code written by programmers and translate it into executable machine code. They also perform various optimizations to make the code run more efficiently.

Project Management:

IDEs offer project management features that help organize code files, manage dependencies and streamline the build process.

Example: In Visual Studio Code, creating a new project sets up a directory structure with folders for source files, libraries, and dependencies, making it easier to manage complex applications.

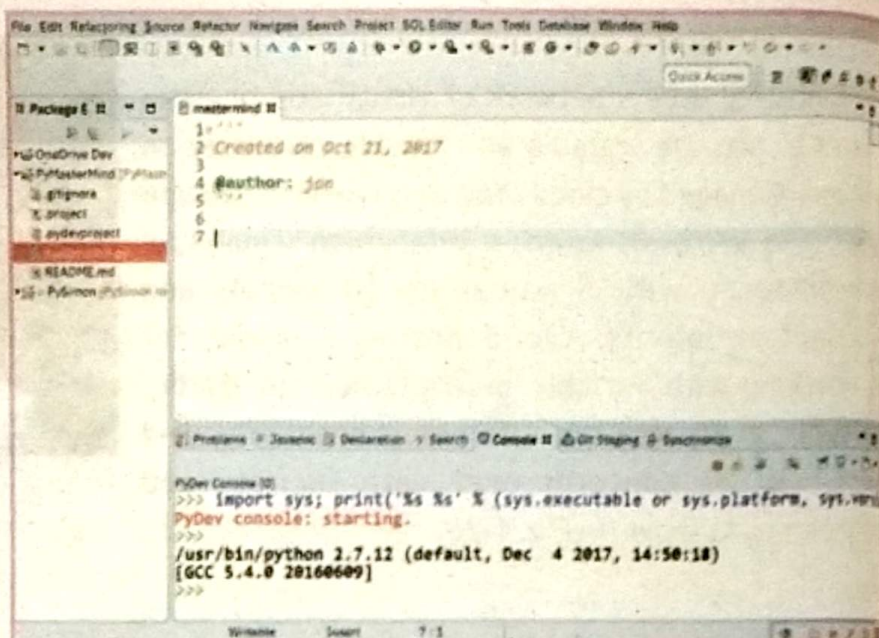

Fig.1.29: Python programming language IDE

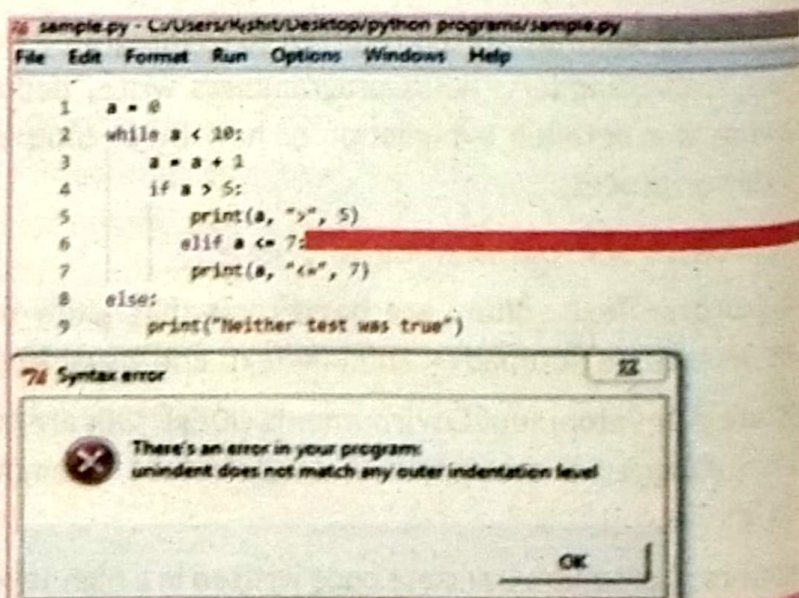

Fig.1.30: Syntax error

Learning Activity

"Hello World! Project"

By following these detailed steps, you can create and run a simple "Hello World!" project using HTML, CSS, and JavaScript directly in Visual Studio Code using your default browser, like google Chrome. This setup allows you to see real-time updates as you make changes to your code.

Setting Up Visual Studio Code for HTML, CSS, and JavaScript

Before you begin, ensure you have [Visual Studio Code installed](#).

Step-by-Step Guide

1. Open Visual Studio Code program. As Shown in Fig 1.31.

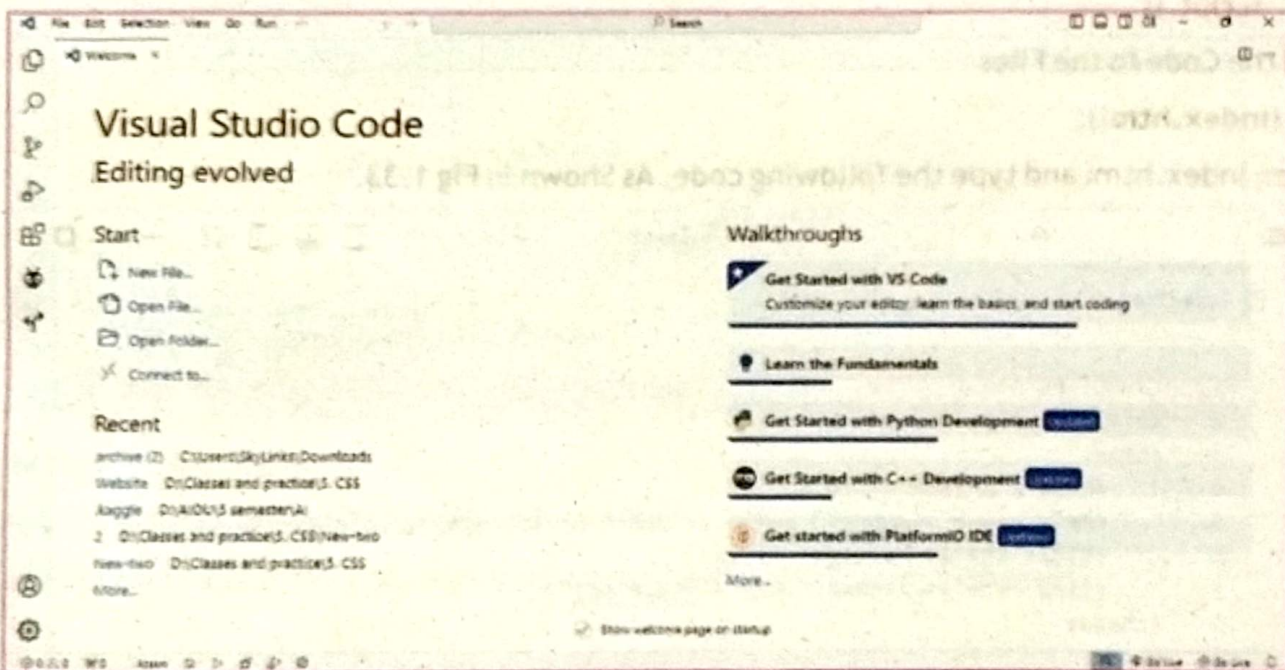

Fig.1.31: Visual Studio Code

2. Create the Project Files:

➤ Create a new folder on your computer and name it HelloWorldProject. As shown in Fig 1.32.

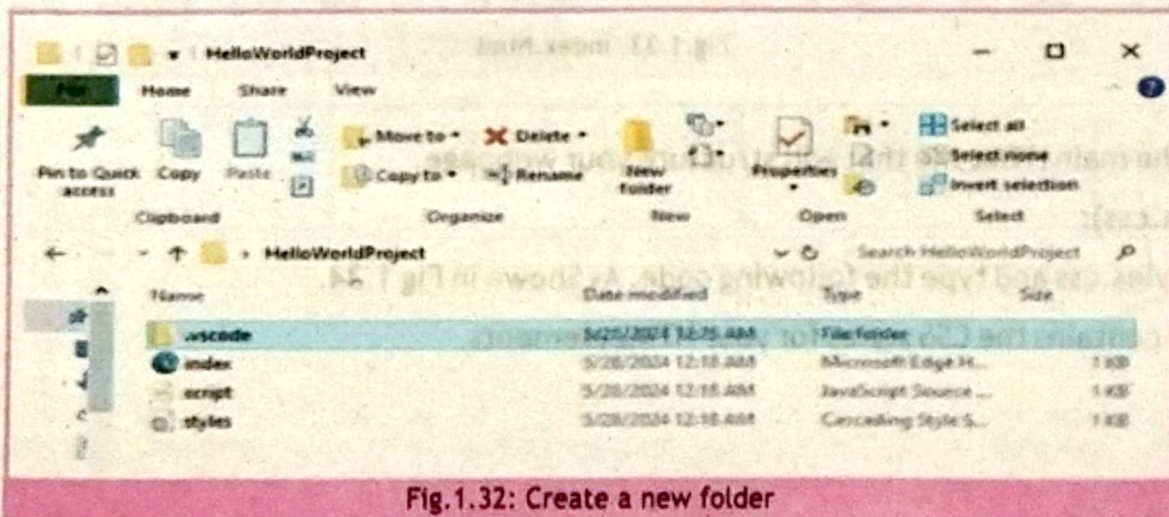

Fig.1.32: Create a new folder

3. Open the Project Folder in Visual Studio Code:

- In Visual Studio Code, click on File > Open Folder....
- Navigate to and select your HelloWorldProject folder.

4. Create HTML, CSS, and JavaScript Files:

- In the Explorer pane on the left side of VS Code, right-click on the folder name (HelloWorldProject).
- Select New File and create the following files:
 - index.html
 - styles.css
 - script.js

5. Add the Code to the Files

HTML (index.html):

- Open index.html and type the following code. As Shown in Fig 1.33.

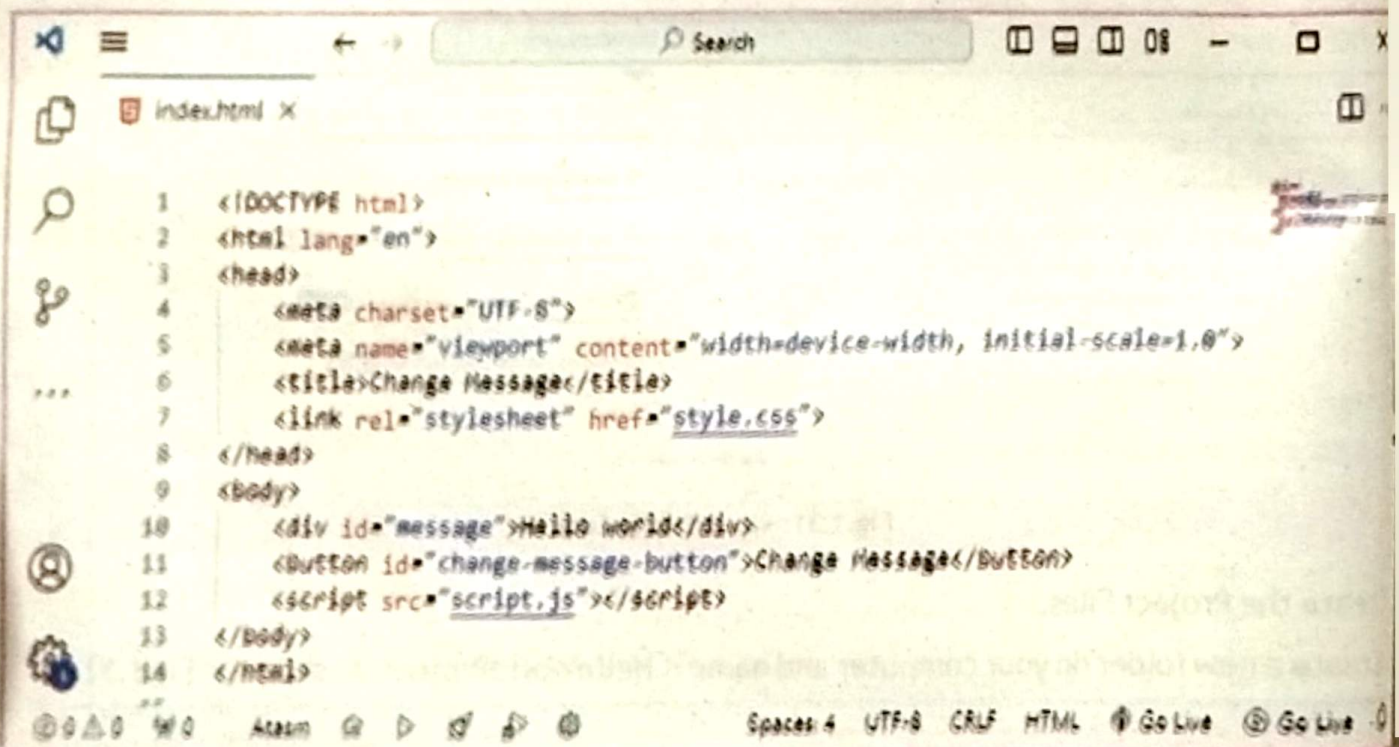

```
1 <!DOCTYPE html>
2 <html lang="en">
3 <head>
4   <meta charset="UTF-8">
5   <meta name="viewport" content="width=device-width, initial-scale=1.0">
6   <title>Change Message</title>
7   <link rel="stylesheet" href="style.css">
8 </head>
9 <body>
10  <div id="message">Hello world</div>
11  <button id="change-message-button">Change Message</button>
12  <script src="script.js"></script>
13 </body>
14 </html>
```

Fig.1.33: index.html

- This is the main HTML file that will structure your webpage.

CSS (styles.css):

- Open styles.css and type the following code. As Shown in Fig 1.34.
- This file contains the CSS styles for your HTML elements.

```

1  body {
2    font-family: Arial, sans-serif;
3    display: flex;
4    flex-direction: column;
5    justify-content: center;
6    align-items: center;
7    height: 100vh;
8    margin: 0;
9    background-color: #afefef;
10 }
11
12 #message {
13   color: #333;
14   font-size: 2em;
15   margin-bottom: 20px;
16 }
17
18 button {
19   padding: 10px 20px;
20   font-size: 1em;
21   cursor: pointer;
22   background-color: #4CAF50;
23   color: white;
24   border: none;
25   border-radius: 5px;
26 }
27
28 button:hover {
29   background-color: #45a049;
30 }

```

Fig.1.34: CSS (styles.css)

JavaScript (script.js):

Open script.js and type the following code. As Shown in Fig 1.35.

This file contains the JavaScript code that adds interactivity to your webpage.

```

1  document.addEventListener("DOMContentLoaded", function() {
2    const messageDiv = document.getElementById('message');
3    const button = document.getElementById('change-message-button');
4
5    button.addEventListener("click", function() {
6      if (messageDiv.textContent === 'Hello World') {
7        messageDiv.textContent = 'I Love my country, Pakistan';
8      } else {
9        messageDiv.textContent = 'Hello world!';
10     }
11   });
12 });
13

```

Fig.1.35: JavaScript (script.js)

Running the Example

View in Browser:

- Your default browser (like Google Chrome) should open a new tab displaying your HTML. You should see a "Hello, World!" heading and a "Change Message" button. As Shown in Fig 1.36.

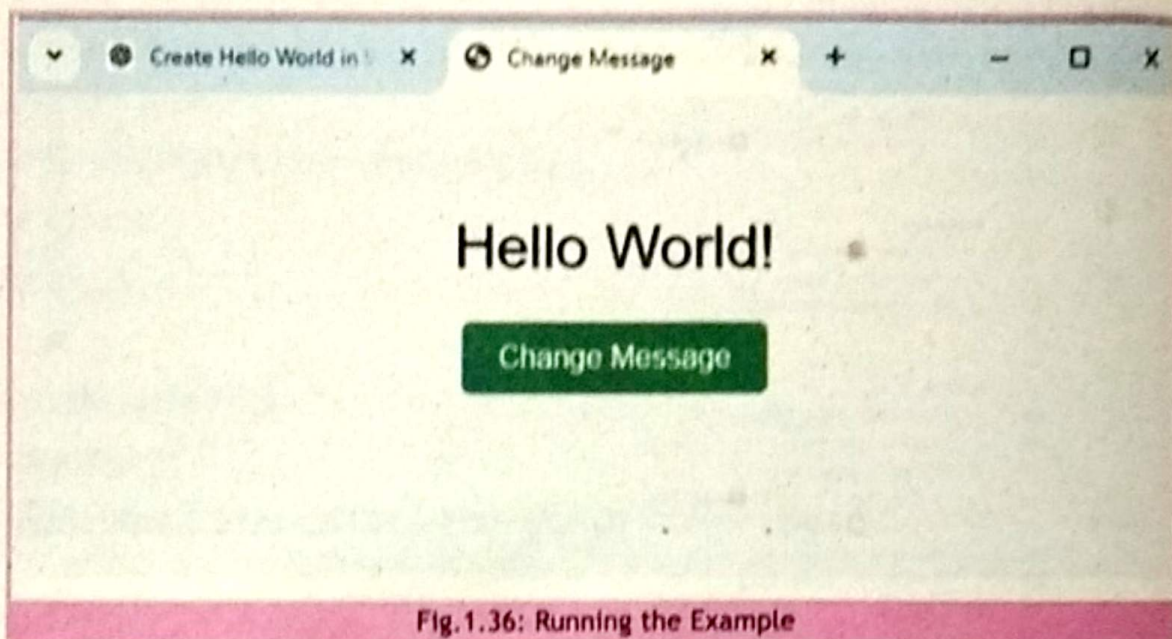

Fig.1.36: Running the Example

- Clicking the Change Message button will activate a JavaScript alert saying "I Love my country Pakistan". As Shown in Fig 1.37.

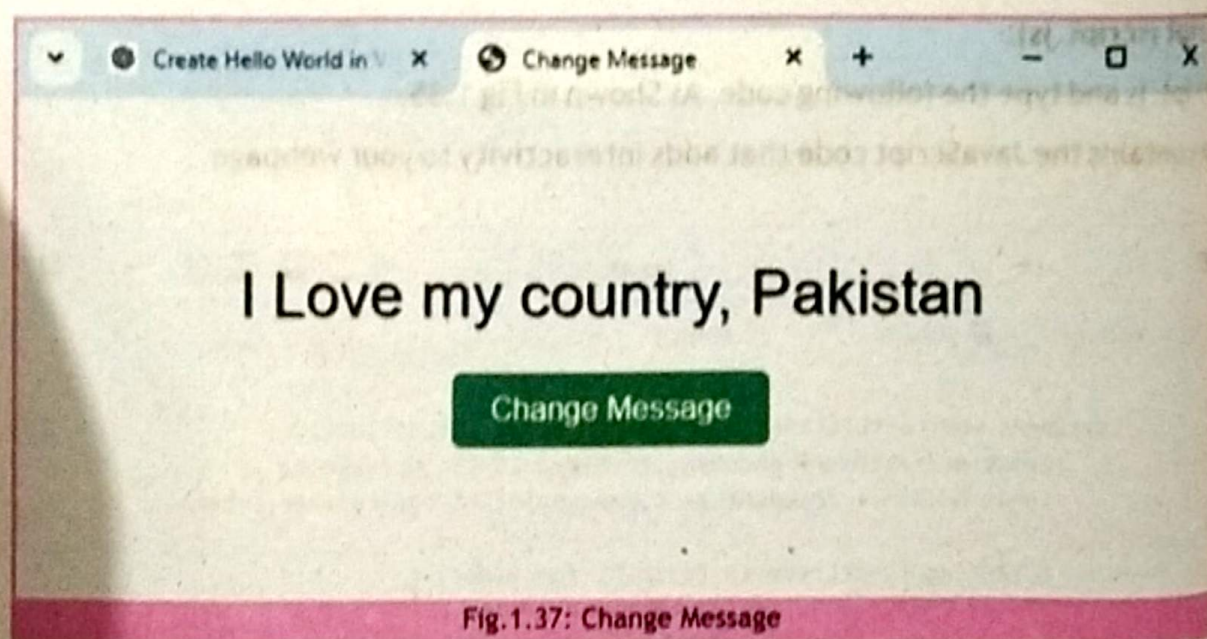

Fig.1.37: Change Message

Unit Summary

- **Machine-Level Representation of Data:** Data is stored in binary (bits) and represented in various data types.
- **Numbering Systems:** Include decimal, binary, octal, and hexadecimal systems for number representation and conversions.
- **Decimal System:** Uses base 10 with symbols 0-9.
- **Binary System:** Base 2, using 0 and 1 for data representation.
- **Octal System:** Base 8, with symbols 0-7.
- **Hexadecimal System:** Base 16, using symbols 0-9 and A-F for compact data representation.
- **Number System Conversions:** Methods to convert between decimal, binary, octal, and hexadecimal.
- **Binary Arithmetic:** Computers perform addition, subtraction, multiplication, and division in binary.
- **Overflow/Underflow:** Occurs when a calculation exceeds or falls below the representable range.
- **Complements (1's and 2's):** Used in binary operations, especially for subtraction.
- **Binary Subtraction:** Done using 1's or 2's complement to simplify operations.
- **Signed/Unsigned Numbers:** Binary numbers can be represented with or without a sign bit to indicate positive or negative values.
- **Floating-Point Representation:** Uses the IEEE 754 standard for storing real numbers, dividing them into sign, exponent, and mantissa.
- **Common Coding Schemes (ASCII/Unicode):** Convert characters into binary; ASCII uses 7 or 8-bit codes, Unicode supports global languages.
- **Operating System (OS) Overview:** Manages memory, processes, devices, and software, enabling user interaction.
- **Main OS Tasks:** Includes managing processes, memory, files, devices, networks, and security.
- **Process Management:** Allocates CPU time and optimizes resource use.
- **Memory Management:** Allocates and manages memory for programs.
- **File Management:** Handles file creation, deletion, and organization.
- **Device Management:** Controls and optimizes input/output devices.
- **Network Management:** Manages network resources and resolves network issues.
- **Security Management:** Enforces security policies and manages user accounts.

- **Batch Processing OS:** Processes tasks in batches, improving efficiency.
- **Multiprogramming OS:** Executes multiple programs simultaneously in memory.
- **Multitasking OS:** Performs multiple tasks at once by quickly switching between programs.
- **Time-sharing OS:** Shares CPU time across programs, simulating simultaneous processing.
- **Real-time OS:** Executes tasks within strict timing constraints, often used in industrial processes.
- **Multiprocessor OS:** Manages multiple CPUs to improve performance.
- **Parallel Processing OS:** Runs multiple processes at once using several processors.
- **Distributed OS:** Manages a distributed system, balancing load for fast execution.
- **Embedded OS:** Built into devices to manage hardware and perform specific tasks automatically.
- **Application Management:** OS manages resources for running applications efficiently.
- **Process Scheduler:** Manages CPU time for process execution, ensuring fairness and efficiency.
- **Process Synchronization:** Coordinates access to shared resources, preventing conflicts.
- **Scheduling Algorithms:** Includes FCFS, SJN/SJF, priority scheduling, and round-robin.
- **Interrupts:** Signals to the CPU that require immediate action, handled by interrupt routines.
- **Deadlock:** Occurs when processes block each other indefinitely over shared resources.
- **System Resources Managed by OS:** CPU, memory, storage, and I/O devices.
- **OS Design:** Includes kernel, process management, memory management, file systems, device management, security, networking, and user interface.
- **File System Structure:** Files, directories, and metadata organized into single-level, two-level, or tree structures.
- **File Allocation Methods:** Contiguous, linked, and indexed methods for storing files.
- **File System Types:** Examples include FAT, NTFS, and ext3/ext4, each with unique features.
- **File Operations:** Include creating, reading, writing, deleting, and renaming files.
- **Software Hosting:** Involves deploying software on servers for network accessibility.
- **On-Premises Hosting:** Software hosted on internal servers, offering control but with high cost.

- **Shared Hosting:** Multiple websites share a single server, offering low cost but potential performance issues.
- **Dedicated Hosting:** A server dedicated to one user, providing high performance and security at a higher cost.
- **Cloud Hosting:** Uses cloud servers for scalability and cost-efficiency, though dependent on connectivity.
- **Programming Software:** IDEs, text editors, and compilers help write, debug, and compile code.
- **Components of Programming Software:** Text editors for writing, IDEs for a full coding environment, and compilers for translating code.
- **Writing Code:** Tools like syntax highlighting and code completion enhance coding efficiency.
- **Debugging:** IDEs provide tools for finding and fixing bugs by stepping through code.
- **Error Checking:** Real-time error checking and syntax highlighting help avoid coding mistakes.
- **System Software:** Manages hardware and system resources, controls operations, and provides a platform for applications (e.g., Windows, macOS).
- **Programming Software:** Offers tools for writing, testing, and debugging code; translates code into machine language (e.g., Eclipse, Visual Studio).
- **Application Software:** Performs specific user tasks such as writing, streaming, or browsing (e.g., Microsoft Word, Spotify).
- **Driver Software:** Enables communication between the operating system and hardware devices (e.g., printer drivers, Wi-Fi drivers).
- **Offline Applications:** Run without internet, rely on local resources (e.g., Microsoft Word, Adobe Photoshop).
- **Online Applications:** Require an internet connection to access data or services (e.g., Google Docs, Spotify, Gmail).
- **Word Processors:** Used for writing documents (e.g., Microsoft Word, Google Docs).
- **Spreadsheets:** For data analysis, budgeting (e.g., Excel, Google Sheets).
- **Presentation Software:** Create presentations for business or education (e.g., PowerPoint, Google Slides).
- **Database Management:** Organize large datasets (e.g., Microsoft Access, MySQL).
- **Email Clients:** Manage emails and appointments (e.g., Outlook, Thunderbird).
- **Note-Taking Apps:** Organize notes and tasks (e.g., Evernote, OneNote).

Exercise

Q1. Select the best answer for the following MCQs.

1. What is the binary representation of the decimal number -43 using 8-bit two's complement notation?
a) 10101011 b) 11010101 c) 11010101 d) 11101011
2. Which of the following binary numbers corresponds to the hexadecimal number 3FA7?
a) 0011 1111 1010 0111 b) 1100 0011 1101 1000
c) 1011 1100 0011 0111 d) 0111 1011 1011 1100
3. How does the ASCII code for the character 'Z' (90 in decimal) look in binary?
a) 01011010 b) 01001110 c) 01011000 d) 01101001
4. In an 8-bit signed integer representation, what is the range of values that can be represented?
a) -127 to 128 b) -128 to 127 c) 0 to 255 d) -256 to 255
5. How many different values can be represented with a 10-bit binary number?
a) 256 b) 1024 c) 512 d) 2048
6. Which of the following is **NOT** a task performed by an operating system?
a) Process Management b) Memory Management
c) Email Management d) Device Management
7. Which type of operating system allows multiple tasks to be performed at the same time?
a) Multiprogramming b) Batch Processing c) Real-time d) Single-tasking
8. Which state of a process represents that it is ready for execution but waiting for CPU time?
a) Start State b) Running State c) Ready State d) Blocked State
9. What is the main purpose of a process scheduler?
a) To manage file operations b) To manage CPU utilization
c) To manage memory allocation d) To manage network resources
10. Which memory management approach involves dividing memory into fixed-sized blocks?
a) Paging b) Segmentation
c) Virtual Memory d) Contiguous Allocation
11. What is the main purpose of interrupts in an operating system?
a) To speed up CPU processing b) To slow down CPU processing
c) To handle immediate events d) To manage network connections

12. Which scheduling algorithm assigns CPU time in fixed time slices to each process in a cyclic order?
- a) First-Come First-Served (FCFS)
 - b) Shortest Job Next (SJN)
 - c) Priority Scheduling
 - d) Round Robin (RR)
13. Which memory management technique divides memory into fixed-sized blocks?
- a) Segmentation
 - b) Paging
 - c) Fixed Partitioning
 - d) Dynamic Partitioning
14. Which type of hosting involves installing and running software on servers located within an organization's physical premises?
- a) Shared Hosting
 - b) Dedicated Hosting
 - c) On-Premises Hosting
 - d) Cloud Hosting
15. Which component of programming software translates code written in a high-level programming language into machine code?
- a) Text Editor
 - b) Compiler
 - c) Debugger
 - d) IDE

Q2. Write answers of the following short response questions.

1. What is the significance of the Most Significant Bit (MSB) in signed binary numbers?
2. What is a binary digit, and why is it fundamental in computer systems?
3. Why are binary numbers more efficient for computer calculations than decimal numbers?
4. How do ASCII and Unicode differ in character representation?
5. What is the importance of positional value in number systems? Give two examples.
6. What is the process to convert a binary number to its hexadecimal equivalent?
7. What is the purpose of machine code in computer operations?
8. Why coding scheme is used in computer? Give three reasons.
9. State five differences between a process and a thread.
10. What is memory management and how does it work in an operating system?
11. What is a real-time operating system and where is it commonly used?
12. Differentiate between multiprogramming and multitasking operating systems.
13. List two pros and two cons of on-premises hosting.
14. What is an application patch? Give key functions of it.
15. Differentiate between offline and online applications. Give one example of each.

Q3. Write answers of the following extended response questions.

1. Explain decimal, binary, octal and hexadecimal number systems with examples.

2. What is 2's complement, and why it is used? Give examples.
3. Define the terms Overflow and Underflow. Explain Overflow in number system with one example.
4. What is the significance of ASCII and Unicode character coding schemes?
5. What is an operating system? Explain any five tasks/functions of OS.
6. Explain any four types of operating systems.
7. How operating system manages applications? Explain five states of a process with diagram.
8. Explain the role of Integrated Development Environments (IDEs) in the software development process, including specific features that enhance programming efficiency.
9. What is software hosting? Explain On-premises and Cloud hosting. Also give two pros and cons of each.



Learning Outcomes

At the end of this unit students will be able to:

- identify common algorithms used to develop software, store, search, or sort information.
- develop and apply abstractions to create generalized, modular solutions.

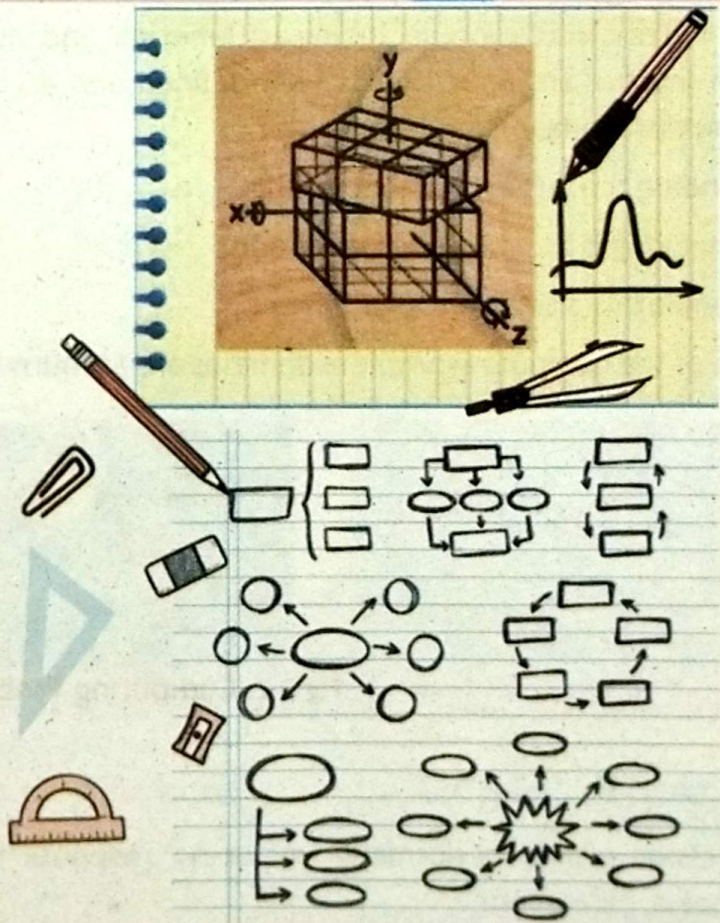

Introduction

Computational Thinking (CT) is a way of solving problems by using ideas from computer science. It helps you break down big problems into smaller parts and come up with step-by-step solutions that a computer or a person can follow.

CT isn't just about coding; it's a basic skill useful in any area. It involves using mental tools and strategies to think more clearly, logically, and creatively.

Computational thinking simplifies difficult issues into doable stages. It teaches you to think through many strategies and create logical answers, or algorithms. Critical thinking encourages innovation and efficient use of technology to solve issues in any industry.

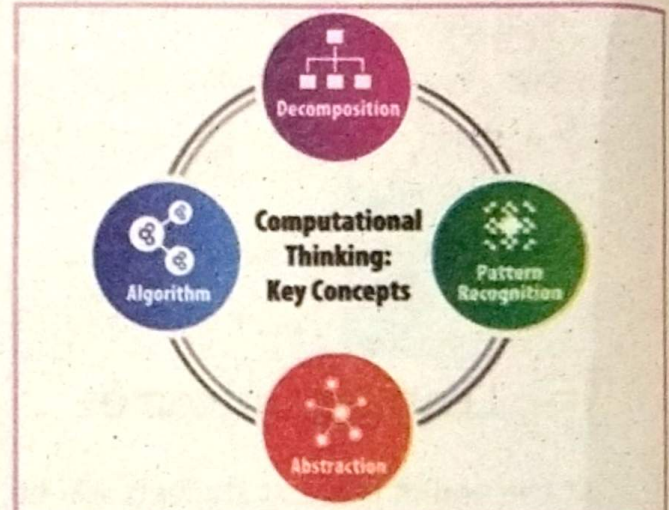

Fig.2.1: Computational Thinking (CT)

2.1 Computing Problems

A computing problem in computer science is one that is solved step-by-step through computation. Any kind of calculation, including arithmetical and logical ones, can be included. These problems often involve an input that is well-defined and an output that needs to satisfy a few desired properties. Some examples include:

- Finding the largest number in a list.
- Checking if a number is even or odd.
- Simulating a scientific phenomenon.

Some of the computing problem domains are as follows:

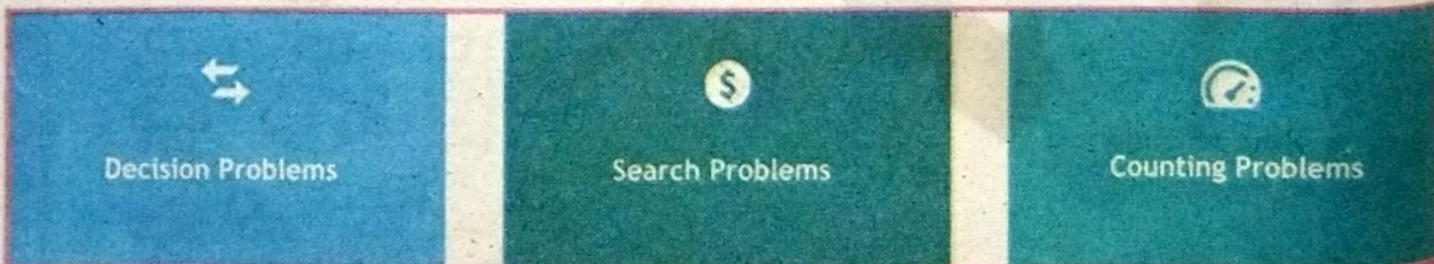

Fig.2.2: Computing Problem Domains

Decision Problems

In decision problems normally 'yes-or-no' response is found in a choice. For example, given a number n , "is n even?"

However, some decision problems may require more steps to solve. For example:

- Given a number n , "is n prime?" requires more work than just checking number's parity.
- Given a string, is its length greater than 5 characters?
- Given an integer m , is m an even number?

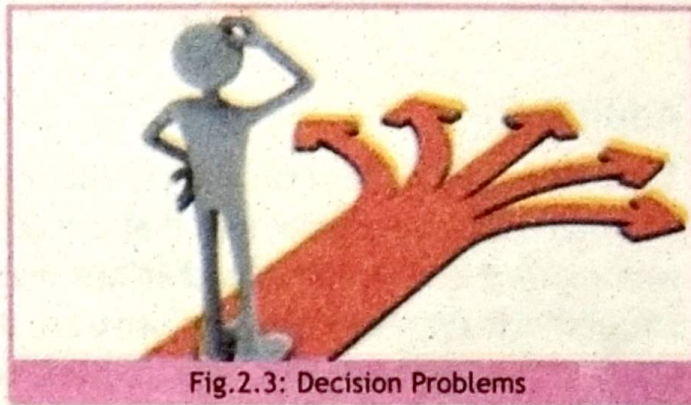

Fig.2.3: Decision Problems

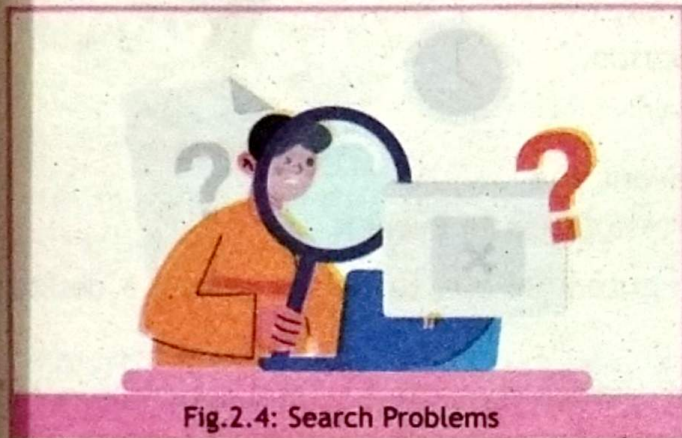

Fig.2.4: Search Problems

Search Problems

In search problems, the solution is made up by having a set of values that satisfy a certain criteria. For example:

- we might wish to calculate a route on a map from one site to another (e.g. from Islamabad to Lahore)

Counting Problems

In counting problems, the number of possible solutions to a search problem is the answer of that counting problem. For the above-mentioned search problem "we might wish to calculate a route on a map from one site to another." The answer of counting problem would be two, supposing we have two roads from Islamabad to Lahore e.g. G.T. Road and Motorway.

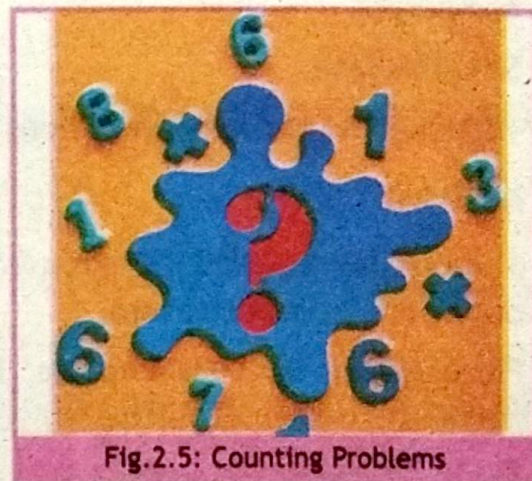

Fig.2.5: Counting Problems

2.2 Basics of Counting Problems

The foundation of counting problems is the basic method of counting while considering the options available to select appropriate items for a given selection.

Tree-based structural approaches are the most effective for solving Counting Principle problems. Counting Principle Problems could easily be understood by the use of tree representation, where the available options are considered as tree branches.

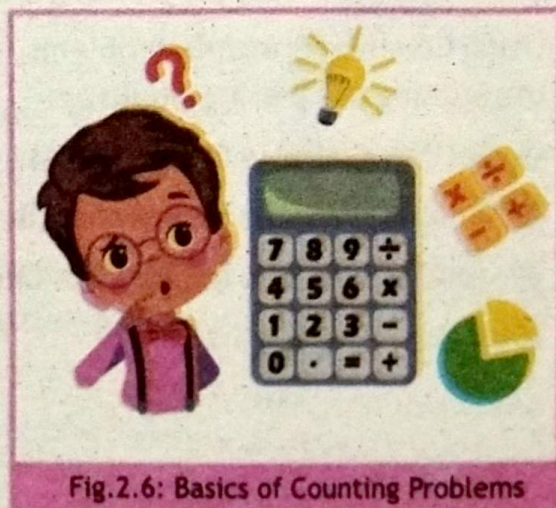

Fig.2.6: Basics of Counting Problems

2.3 Basic Counting Principles

Addition

The addition principle of counting is a basic idea for counting the total number of possibilities that can occur when dealing with many events or options that are mutually exclusive. The events that are mutually exclusive are those that cannot occur simultaneously. This rule is used to get the total number of ways that an event can occur. It is typically used when you have to make a choice between multiple option.

The Addition principle is written as:

Total Possibilities = Number of Possibilities for Event A +
Number of Possibilities for Event B + ... + Number of Possibilities for Event N

For example, a student wants to buy a new computer. He has to decide among 3 desktop computers and 4 laptop computers.

Total number of computer options = Total options in desktop computers + Total options in laptop computers

So in this case

Total number of computer options = $3+4 = 7$

Multiplication

The Multiplication Principle is used when we are dealing with many events, and we have to select one option from each event.

For example: Bilal has 3 Apples, 3 Bananas and 3 bunch of Cherries. In how many ways, he can make fruit basket by putting fruit of one kind.

(A1 B1 C1) (A1 B1 C2) (A1 B1 C3) (A1 B2 C1) (A1 B2 C2) (A1 B2 C3) (A1 B3 C1) (A1 B3 C2) (A1 B3 C3)
(A2 B1 C1) (A2 B1 C2) (A2 B1 C3) (A2 B2 C1) (A2 B2 C2) (A2 B2 C3) (A2 B3 C1) (A2 B3 C2) (A2 B3 C3)
(A3 B1 C1) (A3 B1 C2) (A3 B1 C3) (A3 B2 C1) (A3 B2 C2) (A3 B2 C3) (A3 B3 C1) (A3 B3 C2) (A3 B3 C3)

Using Counting Principle Problems, the total number of ways of choosing this pairing would be:

- Options available for Apples (A) = 3
- Options available for Bananas (B) = 3
- Options available for Bunch of Cherries (C) = 3

Total no. of ways: $3 \times 3 \times 3 = 27$

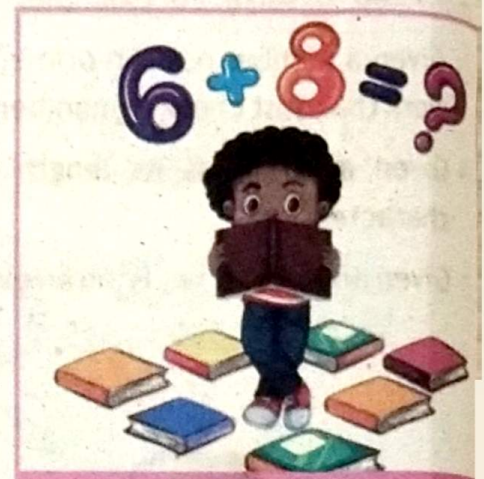

Fig.2.7: Addition

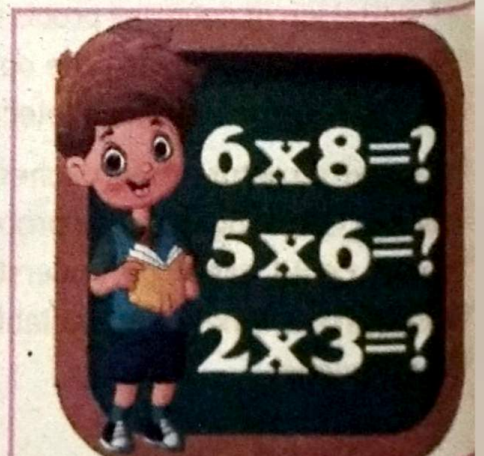

Fig.2.8: Multiplication

Permutation

Many different kinds of problems can be resolved using the Multiplication Principle. Putting objects in order is one kind of challenge. We queue up for pictures, arrange letters into words and digits into numbers, decorate rooms, and more. A permutation is a way to arrange items.

Drawing line segments for each choice can be useful in solving permutation problems. This allows us to multiply by figuring out how many of each option there are.

Assume we have four paintings and three places on the wall to display. We wish to determine how many different ways there are to arrange three of them on a wall. To symbolize the three locations on the wall, we can draw three lines.

_____ x _____ x _____

From these three locations, for the first location have 4 paintings, so we will write 4 on the first location.

4 x _____ x _____

When we have placed the first painting, for 2nd location, we have three choices, so we will write 3 on the second location.

4 x 3 x _____

Similarly, for the 3rd location, we have left with 2 choices, so we will write 2 on the third location.

4 x 3 x 2

So multiplying, these values gives us the answer of 24, means there are 24 permutations possible for the paintings.

Combination

In the above theories and their examples, we have looked at problems where we have to arrange objects in a certain order. There are numerous situations where we wish to pick a few items at random from a collection of things, without regard to the order. The situation, when we are choosing objects and the sequence is irrelevant, this is called combination counting principle.

Consider the above example of paintings that we solved in permutation. So without considering the paintings' order, if we want to determine how many options there are to select three of the four paintings.

Combinations = number of permutations divided by the number of ways to order 3 paintings.

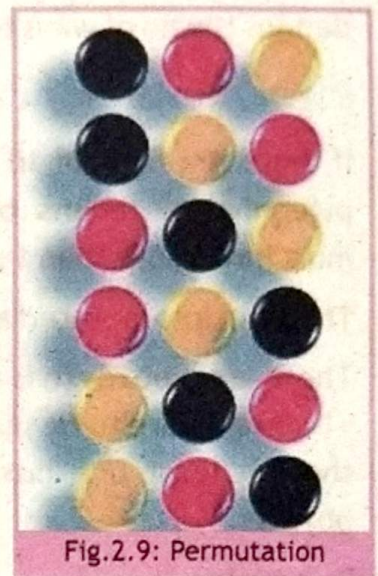

Fig.2.9: Permutation



Fig.2.10: Combination

There are $3! = 3 \cdot 2 \cdot 1 = 6$ ways to order 3 paintings, Hence, there are $24/6 = 4$ combinations that defines the no of ways to select 3 out of the 4 paintings.

Pigeonhole Principle

If there is a flock of 10 pigeons and we have 09 pigeonholes, means one of the pigeonholes must have more than 1 pigeon.

The principle is stated as:

There are n boxes (n is a positive integer) and $n + 1$ objects are to be placed into these n boxes, then at least one box contains two or more objects.

Example

Suppose you have 13 apples and 12 baskets. According to the Pigeonhole Principle, at least one basket will contain more than one apple.



Fig.2.11: Pigeonhole Principle

Inclusion and Exclusion

Recall, the addition principle that states if a task can be performed in one of the n ways or one of the m ways (with no common of two $n+m$), then there are total $n+m$ ways to the task.

But if there are some ways in n and m to do the task, then according to the inclusion-exclusion principle, we must sum the number of ways to complete a task one way and the number of ways to complete it another, and then subtract the number of ways that are shared by both sets of ways in order to count only unique ways of completing the work.

Example:

How many binary strings of length eight have two bits at the end, "00," or begin with a "1" bit?

There are $2^6 = 64$ possibilities to fill in 6 bits if the string ends in '00'.

Similarly, if the string begins with '1', then there are seven bits left in the string and there are $2^7 = 128$ possibilities to fill it.

If add both of the aforementioned sets and consider it the whole solution it will be incorrect according to Inclusion and Exclusion principle of counting because there are strings that both begin with '1' and end in '00,' and since they meet both requirements, they are counted twice.

In order to obtain an accurate count, we must subtract these strings.

There are $2^5 = 32$ possibilities to fill the five characters in strings that begin with '1' and end with '00', accordingly, the inclusion-exclusion principle gives us:

total String = $128 + 64 - 32 = 160$.

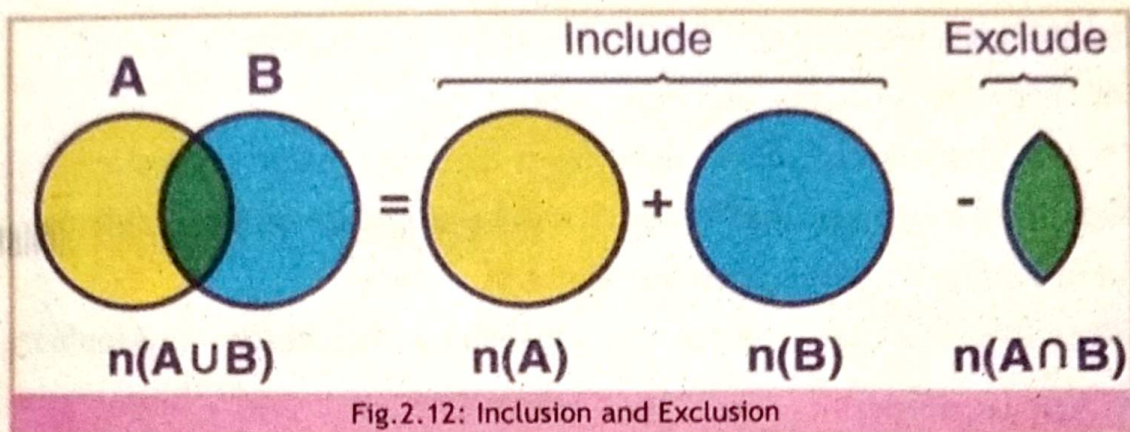

Fig.2.12: Inclusion and Exclusion

2.4 Algorithms and their Characteristics

An algorithm is a well-defined, step-by-step procedure or set of rules for solving a specific problem or performing a task.

Computer science relies heavily on algorithms, which are used for processing data, automating reasoning activities, and doing calculations. They can be expressed in a variety of ways, including computer languages, flowcharts, pseudocode, and natural language.

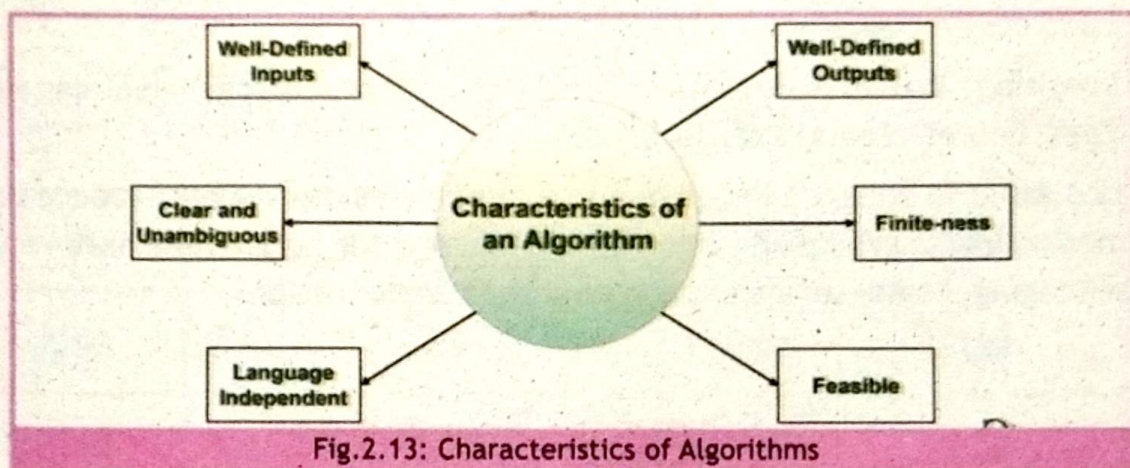

Fig.2.13: Characteristics of Algorithms

Properties of Algorithms

- **Input:** An algorithm can have one or more externally supplied values as inputs.
- **Output:** The outcome of the calculations made by an algorithm is at least one output.
- **Definiteness:** Every algorithmic step needs to be clearly and accurately stated.
- **Finiteness:** There must always be a finite number of steps in an algorithm before it ends.
- **Effectiveness:** An algorithm's operations must be simple enough for a human to execute them with paper and pencil in a reasonable amount of time.
- **Generality:** An algorithm should be able to handle a group of problems rather than simply one particular one. It needs to offer a broad solution for several related problems.

Role of Algorithms in Computational Problem-Solving

In computational problem-solving process, the algorithms are considered essential, because they provide a set of instructions to follow before actually writing the code in a programming language. The following points highlight their importance:

- Algorithms are designed to be efficient in terms of time and space.
- Algorithms automate repetitive and tedious tasks
- Algorithms help in analyzing and breaking down complex problems into manageable steps.
- Once an algorithm is designed and tested, it can be reused for similar problems.
- Algorithms provide precise and accurate solutions
- Algorithms are considered foundation of programming and software development.

Algorithm Applications

The algorithms can be applied to solve various problems such as

- **Sorting and Searching:** For organizing and retrieving data efficiently, algorithms like quicksort, mergesort, and binary search are used.
- **Graph Algorithms:** For finding the shortest paths in navigation applications, Dijkstra algorithm could be used.
- **Cryptography:** TO provide privacy and security in online transactions, such algorithms be used to encrypt and decrypt data.
- **Machine Learning:** To learn from data and make predictions, machine learning algorithms like decision trees, neural networks can be used.
- **Image Processing:** To enhance image quality or compress the image to reduce size or even to analyze images, Image processing algorithms could provide help. These have very critical role in medical imaging, computer vision, and multimedia applications.

2.5 Logical Reasoning

Logical reasoning is the core part of algorithm development. Logical reasoning fits into computational thinking in the following ways:

- **Problem Decomposition:** Logical reasoning is needed to guarantee that each component is treated systematically when breaking large problems down into smaller, more manageable portions.
- **Pattern Recognition:** Logical sequences and linkages are frequently recognized in order to identify patterns in data or processes.
- **Abstraction:** Logical thinking is needed to discern between pertinent and extraneous information in order to simplify complicated problems by concentrating on the most important features.
- **Algorithm Design:** To guarantee the accuracy and effectiveness of the process, logical thinking is a crucial component of creating step-by-step solutions, or algorithms, to issues.

Boolean Logic

In Boolean, two statements or expressions are evaluated in a way that can only have one of two potential values as a result –either true or false. Boolean logic uses logical operator like AND, OR, NOT, etc.

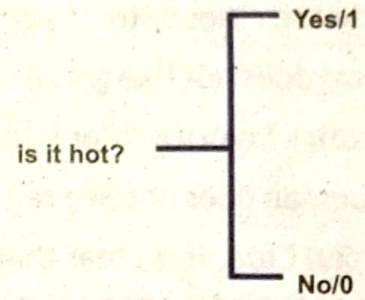

Fig.2.14: Boolean Logic

The above diagram is evaluating an expression regarding today's weather "Is it hot", so it can have either answer 'Yes it is hot - represented with 1' or 'No it is not hot - represented with 0'. Following are few of the most widely used operators with their Venn diagram and truth table.

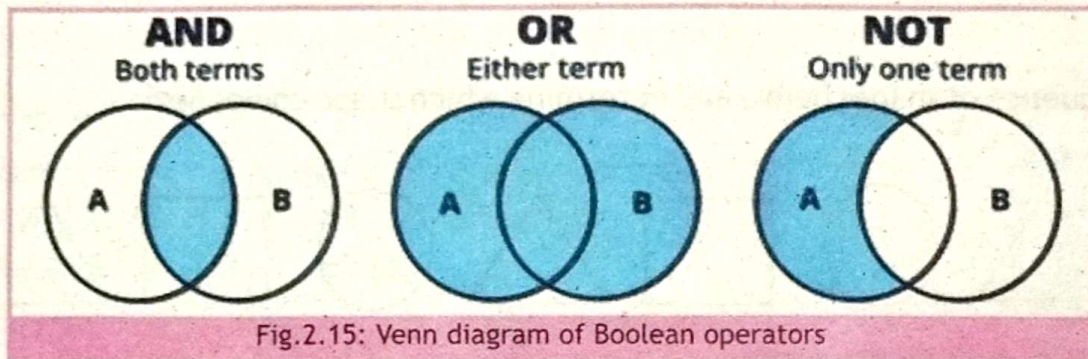

Fig.2.15: Venn diagram of Boolean operators

A	B	A AND B	A OR B	NOT A
False	False	False	False	True
False	True	False	True	True
True	False	False	True	False
True	True	True	True	False

Table 2.1: Truth Table of Boolean operators

Logical Reasoning Types

The logical reasoning questions of wither verbal or non-verbal, the concepts and issues in verbal logical reasoning questions are stated verbally. To attempt such questions, first the provided language or paragraph must be read, comprehend it, and select the appropriate response from the list of possibilities. However, in non-verbal logical reasoning questions, the concepts and issues are presented using figures, pictures, or diagrams.

Example

Among three colors (red, blue, and green), Aiza, Uzair, and Luqman each have different favorit

colors, Use the clues below to determine each person's favorite color.

- » Aiza does not like green
- » Uzair's favorite color is blue
- » Luqman does not like red

From second Clue, it is clear that Uzair's favorite color is BLUE, therefore other two persons can have blue as their favorite color.

From first clue, we came to know that Aiza does not like green and blue color is already the favorite of Uzair, so left option is only RED

Now the only left over option is green, this also does not contradict the third clue. So GREEN is the final option for Luqman.

Example

Look at the sequence of shapes below and determine which shape comes next.

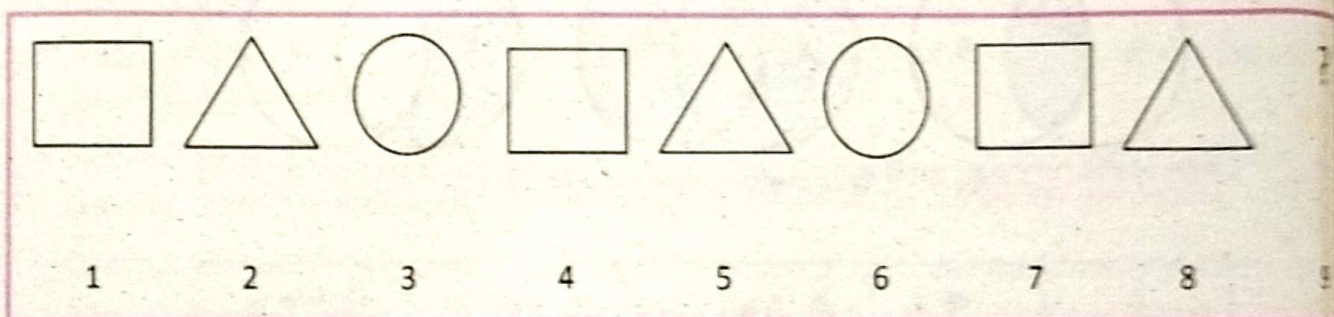

To solve this, observe the pattern in the sequence, We have a a repeating pattern of Square, Triangle, Circle. This pattern repeats every three shapes.

Following the pattern:

- » After Square (1), Triangle (2), Circle (3)
- » It repeats with Square (4), Triangle (5), Circle (6)
- » Again, Square (7), Triangle (8)

The next shape in the sequence, after Triangle, should be a Circle. So, the shape that comes next is a Circle.

2.6 Standard Algorithms

In computational thinking, standard algorithms are fundamental methods used to solve common problems. Understanding these algorithms helps to develop problem-solving skills and provides a foundation for more complex programming tasks. Following are some standard algorithms:

Sorting Algorithms

These algorithms are used to arrange data in a specific order (ascending or descending)

Bubble Sort: Repeatedly steps through the list, compares adjacent elements, and swaps them if they are in the wrong order.

Selection Sort: Divides the list into a sorted and an unsorted part, and repeatedly selects the smallest (or largest) element from the unsorted part to move to the sorted part.

Merge Sort: Divides the list into halves, recursively sorts each half, and then merges the sorted halves.

Insertion Sort: An in-place sorting algorithm that builds the final sorted array one element at a time, shifting elements greater than the current element to the right.

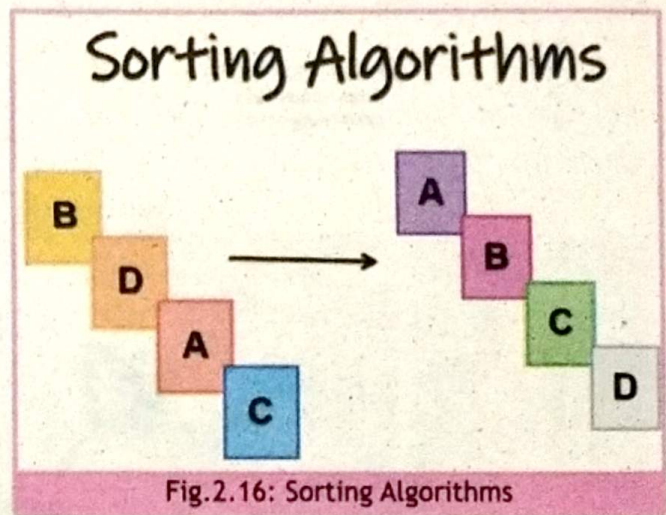

Fig.2.16: Sorting Algorithms

Searching Algorithms

Linear Search: A searching algorithm that sequentially checks each element in a list until the target element is found or the end of the list is reached.

Binary Search: A searching algorithm that works on sorted arrays by repeatedly dividing the search interval in half. It efficiently finds the position of a target value within the array.

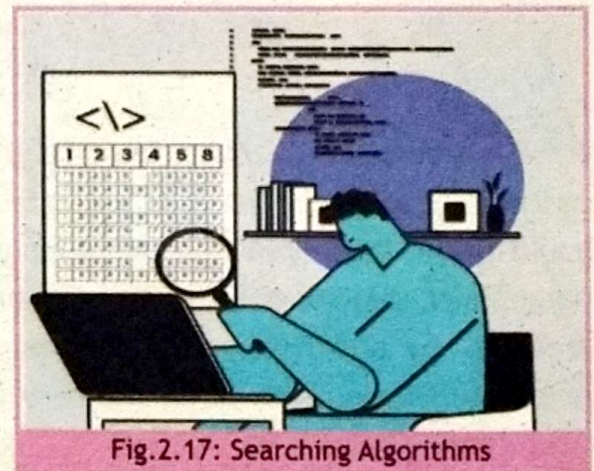

Fig.2.17: Searching Algorithms

2.7 Steps in algorithm to solve computational problems

Core Concepts of Computational Thinking

These core concepts collectively help in designing systems and solving problems efficiently and effectively in various fields. These concepts are:

- **Decomposition:** The problem that need solution could be a complex problem, that may not be solved all at once. Therefore, in decomposition, the complex problems are broken down into sub problems and these sub problems are solved one at a time. By this process, it becomes understandable and simple.
- **Pattern Recognition:** We solve different problems in daily life, but when we analyse, many problems have similar pattern. Identification of these similarities and differences in data or problem helps you to make a general solution.
- **Abstraction:** Focusing on the important information only and ignoring irrelevant details. Abstraction helps in reducing complexity and makes it easier to develop solutions.
- **Algorithms:** Algorithms are the step-by-step solution of a problem. Each step defines some rule to follow that can solve the problem. For automation and efficiency of a system Algorithms are considered essential part of problem-solving.

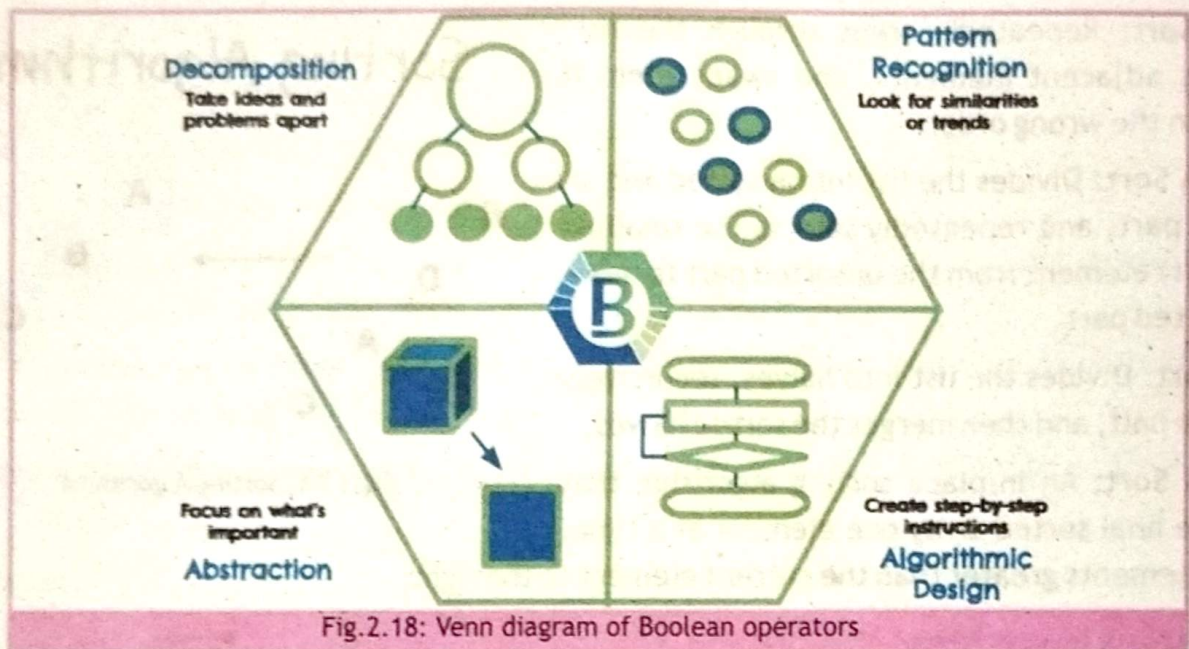

Fig.2.18: Venn diagram of Boolean operators

2.8 Abstraction

While solving problems, specifically complex problems, the concentration should be on core idea and unnecessary components should not be given more attention. By doing this, we are making our problems simple to solve and easy to understand.

- **Maps:** For example, when we are using maps application to reach to some destination, we view the map abstractly, focusing on roads and landmarks and eliminate the minor details like specific plants, trees or houses.
- **Symbols:** We being a smartphone user, considers the icons as applications and does not care about the complex code and procedures that are used to build these applications.
- **Models:** For example, when we plan to construct a house, we only consider architectural models that represents simple depictions of structures. By doing this we can easily communicate design without going into little details.

Let us consider some examples of Abstraction in the filed of Computing

- **Programming Variables:** In our programming chapter, we have dealt with data, and it is abstractly represented by using different variables. Rather than, working with constants we use variables that make our solution generic and easier.
- **Functions:** To make the programming job easier, we are given many built-in functions. These functions are identified using some names and the programmer only call that function by their names, rather than going into detail of activities/ procedures that this function contain. At

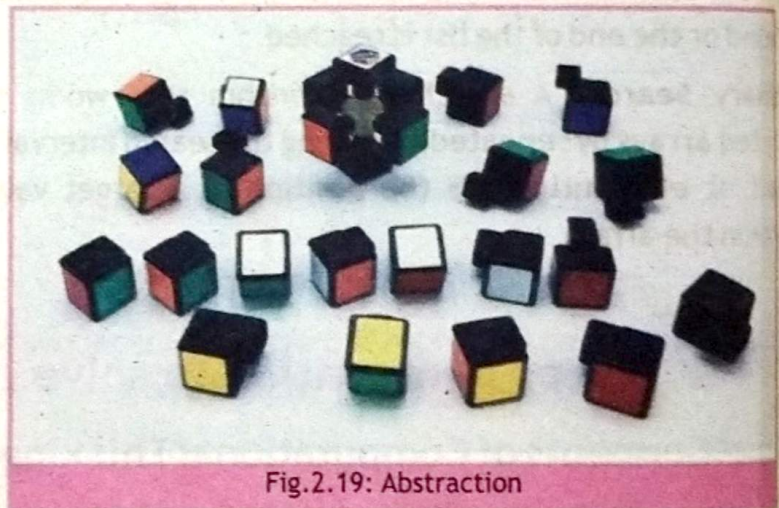

Fig.2.19: Abstraction

advanced level, the programmers also develop their own functions to be used at some later stage in their programming jobs.

- **Object-Oriented Programming (OOP):** In Object Oriented Programming, actual entities are represented with objects. By doing this we conceal the complex details of their implementation.

Example

Steps to Make a Cup of Tea:

1. Boil water.
2. Put tea bag into to the cup.
3. Fill the cup with boiled water.
4. After some time, remove tea bag from the cup.
5. Add sugar (optional).
6. Add Milk (optional).
7. Stir for sometime, Tea is ready.

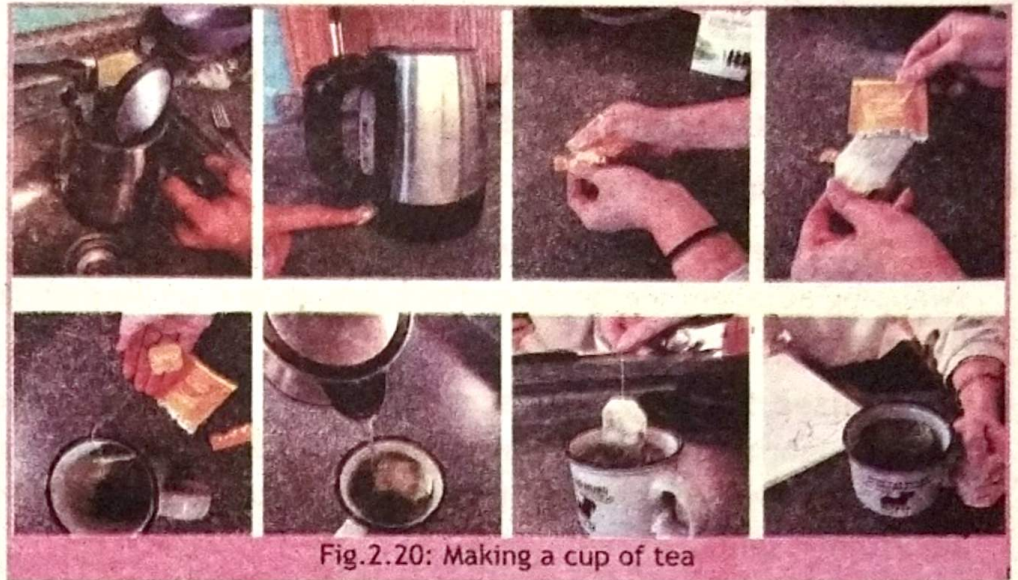

Fig.2.20: Making a cup of tea

2.9 Creating Generalized Solutions

The problems could be specific, but the best solution needs to be generic. The specific solution could only handle that particular situation that is being faced at any particular time. However, the generic solution could be any time to handle similar problems. This way, we can enhance efficiency, scalability and reusability of our solutions.

Steps to Create Generalized Solutions

1. Identify the Core Problem:

- To understand the core problem, first your need to understand specific cases of problems. Among these specific cases of problems, identify the essential components that are common across different cases.

2. Extract Common Patterns:

- Identify Repeated patterns, In problems, there are some elements that occur periodically, identify such elements. Bifurcate the elements whether they are specific to the examples or could be applied more broadly.

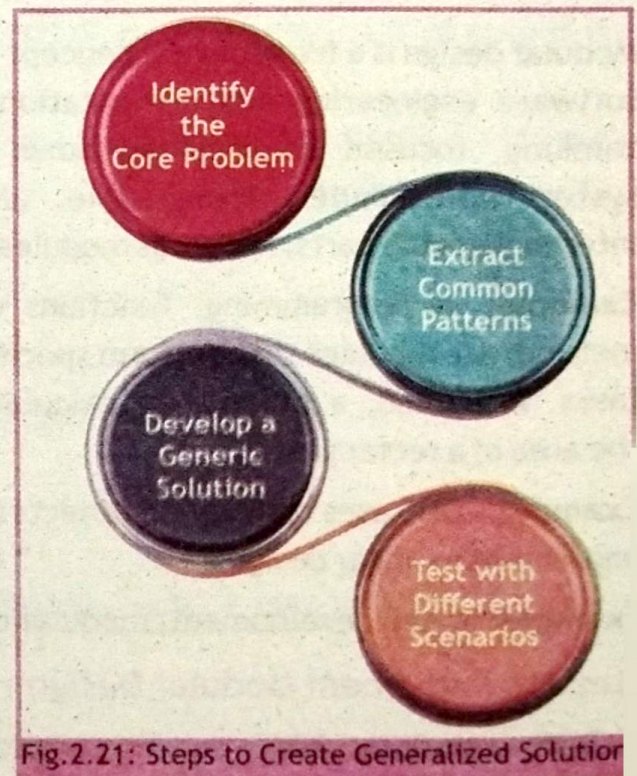

Fig.2.21: Steps to Create Generalized Solution

3. Develop a Generic Solution:

- » Create such a solution that addresses both core and common elements of the problem. It is better to use variables instead of constants, this will help you testing various inputs or conditions.

Test with Different Scenarios:

- » Test the solution with a wide range of inputs to ensure validity of solution in different scenarios. If needed, modify your solution based on test results.

Example: Sorting Algorithms

- » **Specific Case:** In sorting algorithms, the Bubble Sort is a specific solution that works by swapping adjacent elements and this swapping is performed repeatedly, until we get a sorted list of items.
- » **Generalized Solution:** This sorting concept, however, could be generalized, as we have various algorithms for this purpose e.g. Quick Sort, Merge Sort, and Heap Sort. Each of the above algorithms use different strategies to sort the list of items, however, end result of each algorithm is same.

Example: Calculating Area of shapes

- » **Specific Case:** For calculating the rectangle area, we use the formula $\text{length} \times \text{width}$.
- » **Generalized Solution:** There are various shapes, whose area need to be calculated. Therefore, a generalized solution should be created to calculate the area of different shapes (rectangle, circle, triangle). Because, each shape has its own formula, therefore, a function can be created that can handle different shapes along with their parameters.

2.10 Modular Design

Modular design is a fundamental concept in software engineering and computational thinking, focused on breaking down a system into smaller, manageable, and interchangeable parts, known as modules.

Example: In programming, functions or methods are modules that perform specific tasks. In Python, a function to calculate the area of a rectangle:

Example: OOP uses classes and objects to implement modular design.

Example: In web development, modular design can be applied through components and services.

Steps to Implement Modular Design

1. **Define Modules:** While solving complex problems, we divide the problem into sub problems. For each of these sub problems, there will always be core problem that needs to be handled

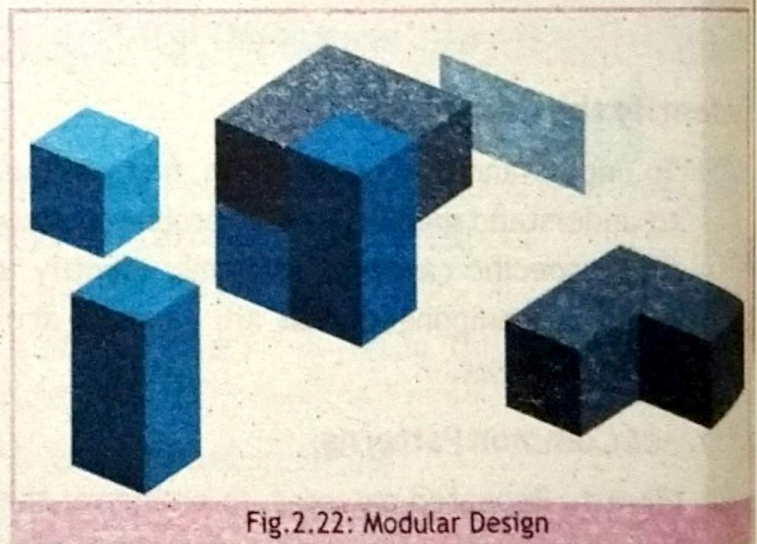

Fig.2.22: Modular Design

For solution of each such core problem, we may define modules.

- 2. Design Interfaces:** Each of the above modules needs to interact with each other. To handle this, connectivity of modules, interfaces for modules could make the job easy. This may include input and output specifications for different interfaces.
- 3. Implement Modules:** The modules (that are in fact solution of sub problems) needs to be implemented according to their defined algorithmic steps and interfaces.
- 4. Integrate Modules:** To come-up with a complete solution of the whole complex problem, combine the modules of the complete system. However, it needs to be ensured that they interact with each other correctly through their interfaces.
- 5. Test Modules:** In testing, both type of testing is necessary, the separate module testing and the complete system testing.

2.11 Algorithm Dry Run

The algorithm dry run means manual checking the execution of an algorithm by providing it specific set of inputs. This helps not only helps to verify algorithm's correctness but also to understand algorithm's behavior on certain inputs and conditions. By doing this, we are also able to identify logical errors, if any.

Steps of Dry Run

- 1. Choose an Input:** To test an algorithm, the first step is the selection of specific set of input values.
- 2. Simulate Execution:** to test algorithm working, each step of the algorithm is manually performed by using the chosen inputs. However, it also needs to keep track of variables states, that may change on performing specific operation.
- 3. Observe Output:** After performing all the required steps of an algorithm, its final output is observed.
- 4. Compare with Expected Result:** The final output of the algorithm is crosschecked with the expected result. If it matches then it means algorithm is correct, otherwise we review each step to identify if some thing have gone wrong.

Example: Performing dry run of algorithm that finds largest number from a a list of numbers.

Algorithm:

- Take a variable max and initialize with the first element of the list.
- Iterate through all the remaining elements of the list.
 - Compare each element with the variable max.
 - If the compared element is greater than the variable max, update max variable with the compared element.

Now max variable contains largest number return it.

Sample Input List: [3, 1, 4, 1, 5, 9, 2, 6]

For solution of each such core problem, we may define modules.

2. **Design Interfaces:** Each of the above modules needs to interact with each other. To handle this, connectivity of modules, interfaces for modules could make the job easy. This may include input and output specifications for different interfaces.
3. **Implement Modules:** The modules (that are in fact solution of sub problems) needs to be implemented according to their defined algorithmic steps and interfaces.
4. **Integrate Modules:** To come-up with a complete solution of the whole complex problem, combine the modules of the complete system. However, it needs to be ensured that they interact with each other correctly through their interfaces.
5. **Test Modules:** In testing, both type of testing is necessary, the separate module testing and the complete system testing.

2.11 Algorithm Dry Run

The algorithm dry run means manual checking the execution of an algorithm by providing it specific set of inputs. This helps not only helps to verify algorithm's correctness but also to understand algorithm's behavior on certain inputs and conditions. By doing this, we are also able to identify logical errors, if any.

Steps of Dry Run

1. **Choose an Input:** To test an algorithm, the first step is the selection of specific set of input values.
2. **Simulate Execution:** to test algorithm working, each step of the algorithm is manually performed by using the chosen inputs. However, it also needs to keep track of variables states, that may change on performing specific operation.
3. **Observe Output:** After performing all the required steps of an algorithm, its final output is observed.
4. **Compare with Expected Result:** The final output of the algorithm is crosschecked with the expected result. If it matches then it means algorithm is correct, otherwise we review each step to identify if some thing have gone wrong.

Example: Performing dry run of algorithm that finds largest number from a a list of numbers.

Algorithm:

- i. Take a variable max and initialize with the first element of the list.
- ii. Iterate through all the remaining elements of the list.
- iii. Compare each element with the variable max.
- iv. If the compared element is greater than the variable max, update max variable with the compared element.
- v. Now max variable contains largest number return it.

Example Input List: [3, 1, 4, 1, 5, 9, 2, 6]

Dry Run:

1. Initialization:

» max = 3 (First element in the list)

Iteration (take element other than first in each iteration):

» Compare 1 with 3: 1 is less than 3, so max will not change.

» Compare 4 with 3: 4 is greater than 3, update value of max to 4.

» Compare 1 with 4: 1 is less than 4, so max will not change.

» Compare 5 with 4: 5 is greater than 4, update value of max to 5.

» Compare 9 with 5: 9 is greater than 5, update value of max to 9.

» Compare 2 with 9: 2 is less than 9, so max will not change.

» Compare 6 with 9: 6 is less than 9, so max will not change.

Result:

» max contains 9, return this value.

If you visually see your input list, 9 is the largest number and our dry run of the algorithm have also correctly identified 9 as the maximum number. This shows that the algorithm steps are working as intended. The dry runs are the powerful tool that can be used to validate the algorithm logic before writing the code.

Trace Table

A trace table are also used to verify the algorithm correctness. While tracing the algorithm, the trace table records the values of variables and their respective change at each of the algorithm step. The final values of the variables are considered final output of the algorithm.

Step	Current Element	Max (Initial)	Updated Max	Comment
0	3	3	3	Initialize max with first element
1	1	3	3	$1 \leq 3$, so max remains 3
2	4	3	4	$4 > 3$, so update max to 4
3	1	4	4	$1 \leq 4$, so max remains 4
4	5	4	5	$5 > 4$, so update max to 5
5	9	5	9	$9 > 5$, so update max to 9
6	2	9	9	$2 \leq 9$, so max remains 9
7	6	9	9	$6 \leq 9$, so max remains 9
End	-	-	9	Final result

Table 2.2: Trace Table

In the above table at

- Step 0: Initialize max to the first element (3).
- Step 1: Compare 1 with 3. Since 1 is not greater than 3, max remains 3.
- Step 2: Compare 4 with 3. Since 4 is greater than 3, update max to 4.
- Step 3: Compare 1 with 4. Since 1 is not greater than 4, max remains 4.
- Step 4: Compare 5 with 4. Since 5 is greater than 4, update max to 5.
- Step 5: Compare 9 with 5. Since 9 is greater than 5, update max to 9.
- Step 6: Compare 2 with 9. Since 2 is not greater than 9, max remains 9.
- Step 7: Compare 6 with 9. Since 6 is not greater than 9, max remains 9.
- End: The final maximum value is 9.

This trace table shows how the algorithm processes each element of the list and how the max value is updated accordingly.

2.12 Errors

There are two of errors and understanding these errors helps in developing accurate and effective problem-solving strategies.

- **Syntax Errors:** Mistakes related to the structure of an expression or statement, similar to grammatical errors in writing.
- **Logical Errors:** Mistakes in reasoning or planning that lead to incorrect conclusions or results, akin to flawed problem-solving approaches.

Consider the example of Search Engine Query, where search engine returns irrelevant results due to a both logical and syntax error in the query.

Query : "Best smartphones for college students under 500"

Here, the user meant to exclude used phones but gets results including them, it has the logical error

so refine query will be

"Best new smartphones for college students under 500."

Still the user is getting irrelevant result due to syntax error of not writing the currency e.g PKR

So, the refine query will be

"Best new smartphones for college students under PKR 500."

Unit Summary

- **Computational Thinking** is a way of solving problems by using ideas from computer science.
- **Computing problem** in computer science is one that is solved step-by-step through computation.
- In **decision problems** normally 'yes-or-no' response is found in a choice
- In **search problems**, the solution is made up by having a set of values that satisfy a certain criteria.
- **Addition principle of counting** is a basic idea for counting the total number of possibilities that can occur when dealing with many events or options that are mutually exclusive.
- The **Multiplication Principle** is used when we are dealing with many events, and we have to select one option from each event.
- A **permutation** is an arrangement of all the members of a set into a specific sequence or order.
- A **combination** is a selection of items from a set where the order of selection does not matter.
- The **Pigeonhole Principle** states that if more items are put into fewer containers than there are items, at least one container must contain more than one item.
- The **Principle of Inclusion and Exclusion** calculates the size of the union of overlapping sets by adding the sizes of the sets and then subtracting the sizes of their intersections.
- An **algorithm** is a well-defined, step-by-step procedure or set of rules for solving a specific problem or performing a task.
- **Sorting** is the process of arranging items in a specific order.
- **Searching** is the process of finding a particular item within a set.
- **Logical reasoning** is the basis for developing and evaluating algorithms, it is an essential part of computational thinking
- In **Boolean**, two statements or expressions are evaluated in a way that can only have one of two potential values as a result – either true or false.
- **Bubble Sort**: Repeatedly steps through the list, compares adjacent elements, and swaps them if they are in the wrong order.
- **Selection Sort**: Divides the list into a sorted and an unsorted part, and repeatedly selects the smallest (or largest) element from the unsorted part to move to the sorted part.
- **Merge Sort**: Divides the list into halves, recursively sorts each half, and then merges the sorted halves.

Exercise

Q1. Select the best answer for the following MCQs.

1. Identify the activity that is based on personal preferences rather than algorithmic logic.
 - a) Sorting numbers in a list.
 - b) Deciding what to eat for dinner.
 - c) Determining if a number is a prime number.
 - d) Calculating the square root of a number.
2. Counting Principle Problems could easily be understood by the use of
 - a) Graph representation
 - b) Tree representation
 - c) Clock representation
 - d) Map representation
3. In how many ways can you choose 2 out of 5 different books to take on a trip? (Order does not matter)
 - a) 10
 - b) 20
 - c) 15
 - d) 5
4. A committee of 3 members is to be selected from a group of 8 people. How many different committees can be formed?
 - a) 56
 - b) 84
 - c) 28
 - d) 120
5. You have 5 different shirts and 4 different pants. How many different outfits can you make by choosing one shirt and one pair of pants?
 - a) 9
 - b) 20
 - c) 15
 - d) 10
6. In how many ways can you select 3 different fruits from a basket of 7 different fruits? (Order does not matter)
 - a) 35
 - b) 21
 - c) 56
 - d) 84
7. The Pigeonhole Principle states that if more items are placed into containers than the number of containers, then:
 - a) Some containers must be empty
 - b) At least one container must hold more than one item
 - c) All containers will be full
 - d) Each item will be placed in a different container

8. In a set of 50 students, 30 have completed a math project, 25 have completed a science project, and 15 have completed both. How many students have completed at least one project?
- a) 35 b) 40 c) 45 d) 50
9. Which property of an algorithm ensures that it produces at least one output after the calculations?
- a) Input b) Output c) Definiteness d) Finiteness
10. Which property ensures that an algorithm will eventually end after a finite number of steps?
- a) Input b) Finiteness c) Effectiveness d) Generality

Q2. Write answers of the following short response questions.

1. Consider 3 boys and 3 girls want to team up as pair for the 14th August related student performance at the school. Find the total no. of ways these pairs could be formed using Counting Principle Problems.
2. Suppose you have selected black pant to attend school function and have three options of shirt to choose. Find the total no. of ways you can dress up using Counting Principle Problems.
3. You are sitting at a study table doing homework. The penholder on the table contains 2 blue pens, 1 black pen, and 2 lead pencils. How many options do you have for writing?
4. For a race on sports day activities, a group of 20 students are given a race lane at random. There are six students selected for the first race. How many different orders of the six lanes for students may be chosen?

Q3. Write answers of the following extended response questions.

1. Ejaz, Javeria, Liaqat, and Zainab are standing in a line. Here are the clues to determine their positions:
 - a) Javeria is standing directly behind Ejaz.
 - b) Zainab is not next to Liaqat.
 - c) Liaqat is not at the end of the line.
 - d) Zainab is standing in the first position.

In which order are they standing?

2. Provide students with a detailed map of their school. Ask them to create an abstract version, highlighting only the main buildings and pathways.

3. Give students a problem that can be solved with a simple program. Encourage them to write functions to handle different parts of the problem, abstracting complex operations into manageable pieces.
4. Given the following web form inputs, identify any syntax errors and correct them

Form Inputs:

➤ Name: AmjadAli ➤ Email: amjadali@gmail ➤ Date: 01/01/2024

5. You have developed a web application that takes the budget head and provides total. Analyze the following budget and identify any logical errors in the total amount.

Budget Example:

- Rent: \$1000
- Utilities: \$150
- Groceries: \$200
- Total: $\$1000 + \$150 + \$200 = \1500



Activity-1

Provide students with a detailed map of their school. Ask them to create an abstract version, highlighting only the main buildings and pathways.



Activity-2

Give students a problem that can be solved with a simple program. Encourage them to write functions to handle different parts of the problem, abstracting complex operations into manageable pieces.



Learning Outcomes

At the end of this unit students will be able to:

- differentiate between front-end development, and backend development of a website.
- use more advanced HTML/CSS features in an appropriate environment.
- use more advanced programming constructs (lists, etc.) to create dynamic websites using JavaScript as backend scripting
- implement complex algorithms that use more complex data structures (lists, etc.) in JavaScript
- determine more advanced techniques (unit tests, breakpoints, watches) for testing and debugging their code in JavaScript

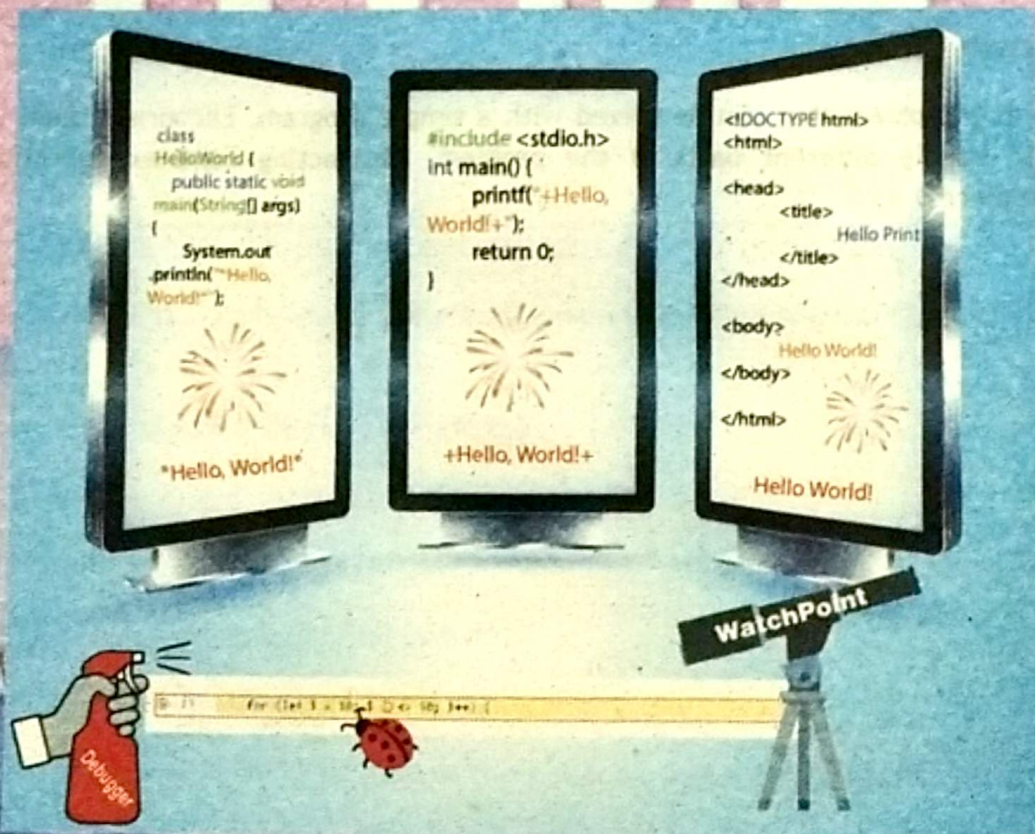

3.1 Website Development

The development of a website first needs a plan, next tools & resources are chosen & gathered and then it is constructed. It is important to first understand the purpose of the website and the actions you would like visitors to do. Next, you design the navigation layout and appearance of the website. The website is then created using code to accomplish your desired goals. Upon completion, you test the system to ensure proper functioning. The website is finally launched and accessible to everyone.

A website development can be split into two segments, the front-end and the back-end. The most common reasons are:

- First of all, website development & maintenance is easier when the front-end and back-end are kept apart
- Secondly, not everyone is an expert at both. Developers may each concentrate on their areas of expertise because front-end and back-end developers work independently. While back-end developers take care of the technical details like databases and server logic, front-end developers focus on making the website appear attractive and be user-friendly.

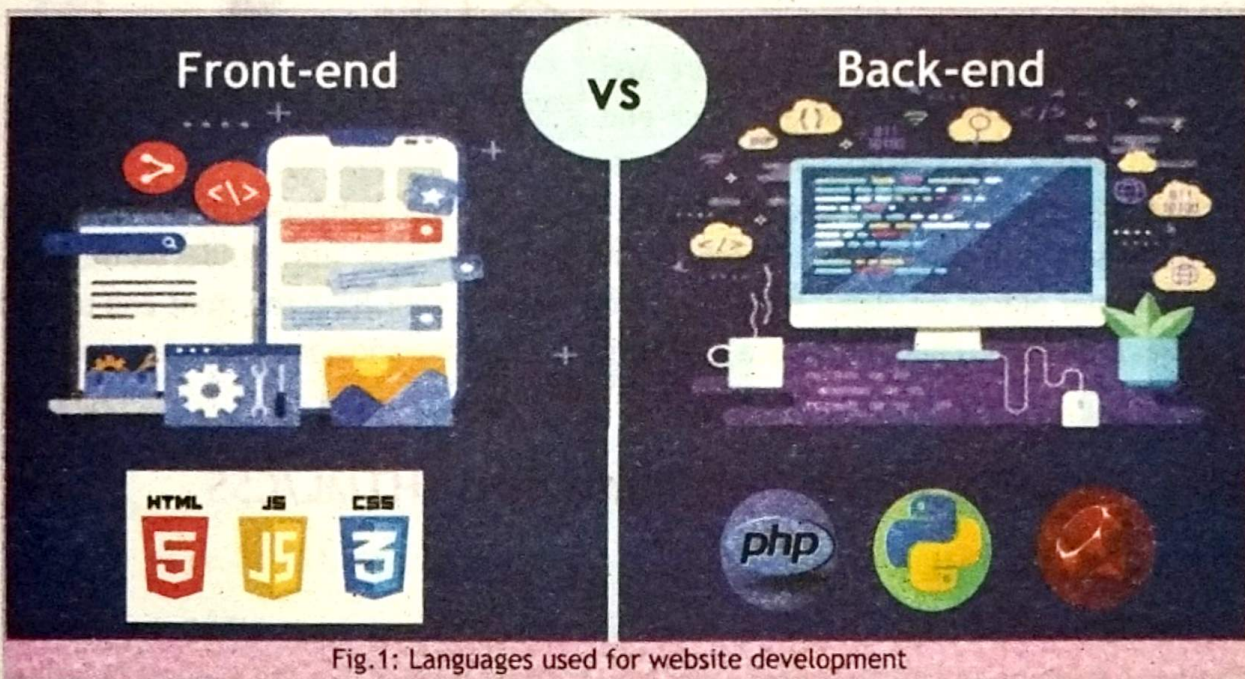

Fig.1: Languages used for website development

In a website the front-end comprises of everything you see and interact with, such as buttons and images. It is designed to be user-friendly. Front-end developers are responsible for making the website attractive and user-friendly. To do this, they use languages like HTML, CSS, and JavaScript. Front-end is also referred as client-side.

The back-end is where all the data resides and is displayed on-demand basis. Since, the data generally resides on the server, the back-end is also referred as server-side. Back-end developers ensure that everything functions properly behind the website. Back-end developers work on the aspects of the website that you cannot see, such as data management, which they accomplish using a variety of coding languages, like Ruby, Python, php etc, as shown in Fig. 1.

When a user interacts with a webpage, the front-end sends requests to the back-end which processes these requests, interacts with databases and generate dynamic content.

Websites with responsive design adjust their functionality and layout to fit different screen sizes, including those of desktop computers, tablets, and mobile phones. One-size-fits-all website design was the norm in the past, which led to awkward presentations on smaller devices. This problem is solved with responsive design, which makes use of adaptable layouts via which items are scaled in proportion to the screen in terms of percentages rather than fixed pixel values. For example, to improve accessibility on a mobile device, a desktop menu may change to a stacked menu.

For instance, for developing an online store and to run it smoothly both front-end and back-end are required. Shops are created, using the front-end technologies like HTML, CSS and JavaScript, for items to be purchased by the visitors. On the other hand a database comprising of item details, cost and stock, etc. resides on the back-end. When a customer places an order, the order information is sent from the front-end to the back-end. The back-end then checks the data, updates the database and administers the stock.

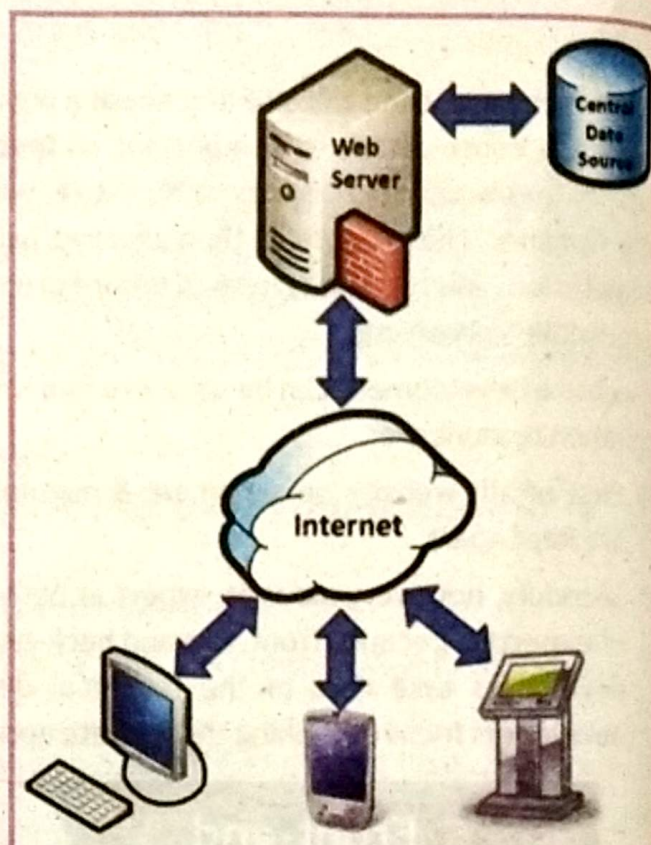

Fig.2: Client-Server architecture

3.2 Additional Features of HTML/CSS

3.2.1 Forms in HTML

HTML controls how web pages appear and navigate based on user input. HTML may display forms containing text boxes and buttons that users can write or click on like the paperwork is filled out. HTML creates spaces where text may be written, items can be selected from lists and check boxes, etc. To take input on an online form, one very useful element for establishing several types of input fields is the `<input>` element. It makes it easier to take user input in multiple ways in forms such as buttons, checkboxes, text fields, etc.

- A particular kind of `<input>` element called a 'list field' allows users to choose one or more items from a list of already available options. These are frequently utilized for checkbox groups or drop-down menus.
- One more type of `<input>` button is a radio button. It lets the user choose just one possibility from a list of options, which is preferred for choices that are mutually exclusive, like gender.

- Checkboxes are useful for lists of preferences since they allow users to pick multiple choices from a group.
- Button is also used to take input and is frequently used for completing forms, navigating to different sites or execute various functions. The "submit" button is a typical example for transferring information from a form to a server.
- HTML also provides with labels which provide information for user. The <label> element is also used to provide a clear title for each input field.
- The form that is used to gather user input is defined within 'form' tag-pair.

For example, in the following lines of code, on second line a label provides information that student's name needs to be entered in the input field which is created with ID 'studentName'. The input field is created in line 3 so that users may enter the student's name.

```

1 <form>
2 <label for="studentName">Student Name:</label>
3 <input type="text" id="studentName" name="studentName"><br><br>

```

With the 'select' tag a drop down list can be created for selecting grade in which the student is. Possible choices of values need to be provided in the next lines so that a drop down list is created for user to choose from the provided choices, only. For instance, to provide choices of 3 classes from 8 to 10, the code should be:

```

5 <label for="grade">Grade:</label>
6 <select id="grade" name="grade">
7 <option value="1">8</option>
8 <option value="2">9</option>
9 <option value="3">10</option>
10 </select><br><br>

```

Mutually exclusive scenarios, where only one among many choices can be true at a time, are catered with radio buttons. To create radio buttons, the input type needs to be set as 'radio' followed by the name for which the radio buttons are set-up and the respective value, for all the choices.

```

12 <label for="gender">Gender:</label>
13 <input type="radio" id="male" name="gender" value="male">
14 <label for="male">Male</label>
15 <input type="radio" id="female" name="gender" value="female">
16 <label for="female">Female</label><br><br>

```

On the other hand, for selecting multiple choices check-boxes are used. To create checkboxes, we just need to specify the input type as 'checkbox' followed by ID. Additionally assign the label-name with which the checkbox relates and the value. Thereafter a corresponding text (label) for the user needs to be placed as well. For example, a student can participate in multiple sports so the input can be taken using checkboxes as:

```

<label for="sports">Sports Participated:</label><br>
<input type="checkbox" id="cricket" name="sports" value="cricket">
<label for="cricket">Cricket</label><br>
<input type="checkbox" id="badminton" name="sports" value="badminton">
<label for="badminton">Badminton</label><br>
<input type="checkbox" id="hockey" name="sports" value="hockey">
<label for="hockey">Hockey</label><br>
<input type="checkbox" id="basketball" name="sports" value="basketball">
<label for="basketball">Basketball</label><br><br>

```

The 'for' attribute when used alongside with the <label> element indicates the form element with which a label is tied to. Such input and label needs to be placed for every input choice, like check-boxes.

Lastly, there is a reset button using <input type="reset" value="Reset"> that allows users to click it to clear every field in the form. If all the above codes are gathered in a single file, the output will look like as shown in figure.

OUTPUT

Student Name:

Grade:

Gender: Male Female

Sports Participated:

Cricket

Badminton

Hockey

Basketball

Lets us design a form for visiting the doctor, for the sake of appointment for a check-up. The code is shown in Fig.3.

To gather particulars of the patients and details about the appointments, are as:

- 'form' tag creates a form on line 8.
- The 'action' tells the form where the input data will be submitted, like 'submit_form.html'.
- The 'method' states the way of submission of data, like 'post'.

Note that the different sorts of data are collected with various 'input type'.

- "text" for names,
- "email" for email addresses,
- "tel" is used for phone numbers,
- "date" takes in the selected date and
- "time" for input time.
- "textarea" element creates a large box to write details for the visit.

```

1 <!DOCTYPE html>
2 <html lang="en">
3 <head>
4 <title>Doctor's Visit Form</title>
5 </head>
6 <body>
7 <h1>Doctor's Visit Form</h1>
8 <form action="submit_form.html" method="post"> <p>Patient Information:</p>
9 <label for="name">Name:</label>
10 <input type="text" name="name" id="name" required> <br>
11
12 <input type="radio" id="male" name="Gender" value="Male">
13 <label for="male">Male</label>
14 <input type="radio" id="female" name="Gender" value="Female">
15 <label for="female">Female</label><br><br>
16
17 <input type="checkbox" id="visit1" name="visit1" value="First">
18 <label for="visit1"> First Visit </label>
19 <input type="checkbox" id="visit2" name="visit2" value="Second">
20 <label for="visit2"> Follow up Visit </label>
21 <input type="checkbox" id="visit3" name="visit3" value="Regular">
22 <label for="visit3"> Regular Check-up Visit</label><br> <br>
23
24 <label for="email">Email Address:</label>
25 <input type="email" name="email" id="email" required> <br>
26
27 <label for="phone">Phone Number:</label>
28 <input type="tel" name="phone" id="phone" required> <br>
29
30 <p>Appointment Details:</p>
31 <label for="date">Date of Appointment:</label>
32 <input type="date" name="date" id="date" required> <br>
33
34 <label for="time">Time of Appointment:</label>
35 <input type="time" name="time" id="time" required> <br>
36
37 <p>Reason for Visit:</p>
38 <textarea name="reason" id="reason" rows="5" cols="30" placeholder="
39 Describe your reason for visit here..."></textarea> <br>
40
41 <input type="submit" value="Submit">
42 </form>
43 </body>
44 </html>

```

Fig.3: Code for creating a form- Doctor's visit

Finally, there is a button for submitting the form and a conformation message is shown in the output in Fig.4.

Doctor's Visit Form (a)

Patient Information:

Name:

Male Female

First Visit Follow up Visit Regular Check-up Visit

Email Address:

Phone Number:

Appointment Details:

Date of Appointment:

Time of Appointment:

Reason for Visit:

	10	00	AM
Mild Fever	11	01	PM
Body Pain	12	02	
	01	03	
	02	04	
	03	05	
	04	06	

(b)

Form Submitted !!!

Thank You for Submitting Your Information

Fig.4: Output of form for Doctor's visit



Activity-1

For the output shown in Fig.4, extend the output for 5 records.



Activity-2

Design and create travel reservation form, like that of Fig.4.

3.2.2 Tables in HTML

An easy approach to organize information on webpages is with tables. They work well for presenting information in an easy-to-read and ordered manner. HTML provides option of tables for viewing of data. A table's basic building block, a cell is a rectangular section that can include text, graphics, etc.

The general structure of the table is created by arranging the cells in rows and columns. The horizontal part that represents one line of information within a table and has a number of table cells is called a row while the vertical classification is termed as column.

A header is a specific kind of table cell to name or classify information contained in other cells in the same column. Usually headers are designed to be eye-catching to highlight their significance like bold, underlined, etc.

HTML provides several attributes for creating and modifying tables, with most commonly used tags being:

- <table> tag indicates the beginning and end of a table. Everything inside is a part of the table.
- The <tr> tag creates a row inside the table. Everything between 'tr' tag-pair covers a single row.

- The <th> tag refers to a table's header cell & contents in <th> cells are in bold and centered.
- <td> tag applies to ordinary table cells. It contains the real data.
- <caption> tag puts a heading or description to the table.
- <thead>, <tbody>, <tfoot> tags divide rows into parts, such as headers, major data and summary.
- colspan/rowspan options allow cells to span several columns or rows, which is convenient for complicated layouts.

In continuation of our example, a sample website with a title is created next in Fig.5, such that a table in HTML is created to display an appointment list. The 'head' section arranges the patient name, date, time, doctor and reason for visit as labels on the top row of the table.

The actual information about appointments is in the 'tbody' section, starting at line 18. There are two sample appointments available right now but we may add more. A 'tr' tag is used for each appointment in a row and a 'td' tag is used for each piece of information inside an appointment. Fig.6 shows the output.

```

1  <!DOCTYPE html>
2  <html lang="en">
3  <head>
4  |   <title>Doctor's Visit Appointments</title>
5  </head>
6  <body>
7  |   <h1>Doctor's Visit Appointments</h1>
8  |   <table>
9  |     <thead>
10 |       <tr>
11 |         <th>Patient Name</th>
12 |         <th>Date</th>
13 |         <th>Time</th>
14 |         <th>Doctor</th>
15 |         <th>Reason for Visit</th>
16 |       </tr>
17 |     </thead>
18 |     <tbody>
19 |       <tr>
20 |         <td>Adil</td>
21 |         <td>2024-05-10</td>
22 |         <td>10:00 AM</td>
23 |         <td>Dr. Shams</td>
24 |         <td>Follow-up</td>
25 |       </tr>

```

```

26 <tr>
27     <td>Zaki</td>
28     <td>2024-05-15</td>
29     <td>2:00 PM</td>
30     <td>Dr. Qamar</td>
31     <td>Check-up</td>
32 </tr>
33 </tbody>
34 </table>
35 </body>
36 </html>

```

Fig.5: Code to display all appointments

OUTPUT

Doctor's Visit Appointments

Patient Name	Date	Time	Doctor	Reason for Visit
Adil	2024-05-10	10.00 AM	Dr. Shams	Follow-up
Zaki	2024-05-15	2:00 PM	Dr. Qamar	Check-up

Fig.6: List of appointments

Though all information is visible on the website in the table, but it is quite congested and hard to read. So, to tidy up and expand the table for better readability we need to know that the space between the borders of neighbouring table cells is determined by border-collapse as shown in Fig.7. The table becomes neater and more compact when the borders are set to "collapse" which causes them to combine into a single line. On the other hand, when the option is set to "separate", the edges stay distinct and the image seems larger.

```

1 <h4>Table with border-collapse: collapse</h4>
2 <table>
3   <tr>
4     <td>Cell 1</td>
5     <td>Cell 2</td>
6   </tr>
7 </table>
8 <h4>Table with border-collapse: separate</h4>
9 <table border="1" border-collapse="separate">
10  <tr>
11    <td>Cell 1</td>
12    <td>Cell 2</td>
13  </tr>
14 </table>

```

Table with border-collapse: collapse

Cell 1 Cell 2

Table with border-collapse: separate

Cell 1 Cell 2

OUTPUT

Fig.7: Border-Collapse

The 'caption' tag provides an overview of the data by placing a caption on top the table, as shown on line 21 in Fig.8.

```
1 <!DOCTYPE html>
2 <html lang="en">
3 <head>
4 <title>Doctor's Visit Appointments</title>
5 <style>
6 table {
7     border-collapse: collapse;
8 }
9 th, td {
10 padding: 10px;
11 text-align: left;
12 }
13 th {
14     background-color: gray;
15 }
16 </style>
17 </head>
18 <body>
19 <h1>Doctor's Visit Appointments</h1>
20 <table>
21     <caption>List of upcoming appointments</caption>
22 <thead>
23 <tr>
24     <th>Patient Name</th>
25     <th>Date</th>
26     <th>Time</th>
27     <th>Doctor</th>
28     <th>Reason for Visit</th>
29 </tr>
30 </thead>
31 <tbody>
32 <tr>
33     <td>Adil</td>
34     <td>2024-05-10</td>
35     <td>10:00 AM</td>
36     <td>Dr. Shams</td>
37     <td>Follow-up</td>
38 </tr>
39 <tr>
40     <td>Zaki</td>
```

```

41         <td>2024-05-15</td>
42         <td>2:00 PM</td>
43         <td>Dr. Qamar</td>
44         <td>Check-up</td>
45     </tr>
46 </tbody>
47 </table>
48 </body>
49 </html>

```

Fig.8: Code to display appointments-refined

OUTPUT

Doctor's Visit Appointments

List of upcoming appointments

Patient Name	Date	Time	Doctor	Reason for Visit
Adil	2024-05-10	10:00 AM	Dr. Shams	Follow-up
Zaki	2024-05-15	2:00 PM	Dr. Qamar	Check-up

Fig.9: Refined layout-list of appointments



Activity-4

Design timetable of your class in html, similar to Fig.9. Add caption 'Timetable for Grade 10'.

Padding is the distance between a cell's border and its content. Padding can be placed to the cell's four sides or specifically to its left, right, bottom or top.

```

1 <table border="1"
2   border-collapse="border-collapse">
3   <tr>
4     <td style="padding: 10px">Cell Number
5     1</td>
6     <td style="padding: 20px">Cell 2</td>
7     <td style="padding: 5px">Cell 3</td>
8   </tr>
9 </table>

```

OUTPUT

Cell Number 1	Cell 2	Cell 3
---------------	--------	--------

Fig.10: Padding

The space among the borders of neighbouring table cells is known as 'cell spacing'. By adjusting the distance between cells, you may make the table appear lengthened.

```

1 <table border="1" cellspacing="20">
2   <tr>
3     <td>Cell Number 1</td>
4     <td>Cell No. 2</td>
5     <td>Cell 3</td>
6   </tr>
7 </table>

```

OUTPUT

Cell Number 1	Cell No. 2	Cell 3
---------------	------------	--------

Fig11: Cell Spacing

You may choose the background color of a table, table row, or specific table cell using background color.

```
1 <table border="1" style="background-color:
  yellow;">
2   <tr>
3     <td>Cell 1</td>
4     <td style="background-color: cyan;
5     ">Cell 2</td>
6     <td>Cell 3</td>
7   </tr>
8 </table>
```

OUTPUT



Fig.12: Background Color

To improve the table's appearance, these basic CSS are applied and evident from output in Fig.8.

- ▶ 'border-collapse' removes additional lines between cells to make the arrangement look more organized (line-7).
- ▶ Padding adds some space around each cell so that cell's text becomes easier to read. (line-10)
- ▶ text-align causes the left side of the cell text to align. (line-11)
- ▶ To help the table headers prominent, a gray background is provided. (line-14)

Another alternate style for displaying the table is to fill the whole breadth of the available area as highlighted in Fig.13. A thin line is added around each cell such that each cell in the table stands out clearly, as shown in Fig. 14.

```
1 <!DOCTYPE html>
2 <html lang="en">
3 <head>
4   <title>Doctor's Visit Appointments</title>
5   <style>
6     table {
7       border-collapse: collapse;
8       width: 100%;
9     }
10    th, td {
11      padding: 10px;
12      text-align: left;
13      border: 1px solid lightgray;
14    }
15    th {
16      background-color: gray;
17    }
18  </style>
19 </head>
```

```

20 <body>
21   <h1>Doctor's Visit Appointments</h1>
22   <table cellpadding="0"> <thead>
23     <tr>
24       <th>Patient Name</th>
25       <th>Date</th>
26       <th>Time</th>
27       <th>Doctor</th>
28       <th>Reason for Visit</th>
29     </tr>
30   </thead>
31   <tbody>
32     <tr>
33       <td>Adil</td>
34       <td>2024-05-10</td>
35       <td>10:00 AM</td>
36       <td>Dr. Shams</td>
37       <td>Follow-up</td>
38     </tr>
39     <tr>
40       <td>Zaki</td>
41       <td>2024-05-15</td>
42       <td>2:00 PM</td>
43       <td>Dr. Qamar</td>
44       <td>Check-up</td>
45     </tr>
46   </tbody>
47 </table>
48 </body>
49 </html>

```

Fig.13: Code for list of appointments - Alternate Method

OUTPUT

Patient Name	Date	Time	Doctor	Reason for Visit
Adil	2024-05-10	10:00 AM	Dr. Shams	Follow-up
Zaki	2024-05-15	2:00 PM	Dr. Qamar	Check-up

Fig.14: Alternative layout displaying list of appointments

3.2.3 Animations in CSS

We can easily change the appearance and movement of elements on a webpage via CSS animation like rotate objects or change color. The animation involves creating a number of key-frames that specify the item's styles at different intermediate moments and sequence in the animation. An element's style during animation is specified by the '@keyframes'.

- To represent each keyframe's location in the animation time-line, a percentage value (ranging from 0% to 100%) is provided (line 15-17).
- The <div> tag on line 22 acts as a container that groups and styles other components as a single unit. It is a useful method for structuring components on websites in a logical manner. It is used for layout purposes.
- Formatting the elements of HTML is defined using the <style> tag. The <head> portion of a web page can contain the <style> tag and the matching page elements receive the styles specified in it.

In the code of Fig. 15 we create a basic CSS animation by spinning a red box repeatedly.

```
1 <!DOCTYPE html>
2 <html lang="en">
3 <head>
4 <title>Simple Animation</title>
5 <style>
6   #animated-box {
7     margin-top: 50px;
8     margin-left: 50px;
9     width: 100px;
10    height: 100px;
11    background-color: red;
12    animation: spin 2s infinite linear;
13  }
14
15  @keyframes spin {
16    from { transform: rotate(0deg); }
17    to { transform: rotate(360deg); }
18  }
19 </style>
20 </head>
21 <body>
22 <div id="animated-box"></div>
23 </body>
24 </html>
```

Fig.15: Code to spin a box

OUTPUT

Fig. 16: Spinning box

An 'animated-box' ID is created with the 'div' element. Additionally, using inline CSS we directly define the style using 'style' tag in HTML head. We implement a spin animation to the element denoted with the ID "animated-box" in this example as shown in Fig.16. This two-second animation (as specified on line 12) repeats itself indefinitely, where the element's start (0 degrees) and finish points are specified (after executing an entire 360-degree spin).

**Activity-5**

Create a rectangle that changes color from red to orange and then orange to blue, with an interval of 5 seconds.

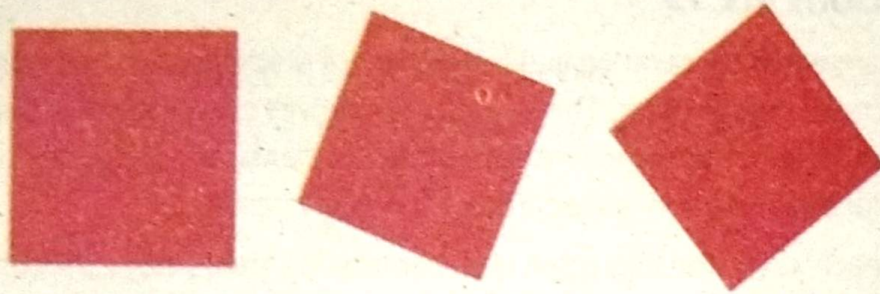
Another example animation is of changing color of the text in a webpage. The code is shown in Fig.17. This animation changes the color of the text the ID "animated-text" assigned to it. The '@keyframes' rule defines the animation and establishes the order in which color changing take place. The applied animation is called "colorChange" and it animates the text to smoothly change from blue to green every two seconds as shown in Fig. 18.

```

1  <!DOCTYPE html>
2  <html lang="en">
3  <head>
4    <title>Color Change Animation</title>
5    <style>
6      #animated-text {
7        font-size: 20px;
8        color: blue;
9        animation: colorChange 2s infinite alternate;
10     }
11
12     @keyframes colorChange {
13       from { color: blue; }
14       to { color: green; }
15     }
16   </style>
17 </head>
18 <body>
19   <p id="animated-text">This text will change color!</p>
20 </body>
21 </html>

```

Fig.17: Code to change Text color

Fig.18: Chaining color of Text from (a) blue to (b) green

We can further extend it to a paragraph where the text in paragraph highlights in various shades of yellow repeatedly, i.e. from lighter to dark shade. This is a simple animation that instead of changing the color text, changes the background color repetitively. Code is listed in Fig. 19.

- Initially this code creates a paragraph element with the ID "highlighted-text".
- Then, to target this specific element, inline CSS styles are applied. An animation with the term "highlight" is used; it repeats endlessly for two seconds.
- This animation highlights the text by changing its background color from translucent to yellow.
- The "@keyframes" rule is used to outline the actual animation sequence.

The text is initially not highlighted and has a translucent background but is changed to yellow to properly emphasize the content as shown in Fig.20.

```

1  <!DOCTYPE html>
2  <html lang="en">
3  <head>
4    <title>Text Highlighting Animation</title>
5    <style>
6      #highlighted-text {
7        font-size: 20px;
8        color: black;
9        background-color: transparent;
10       animation: highlight 2s ease-in-out alternate
11         infinite;
12     }
13     @keyframes highlight {
14       from { background-color: transparent; }
15       to { background-color: yellow; }
16     }
17   </style>
18 </head>
19 <body>
20   <p id="highlighted-text">This text will be
21     highlighted!</p>
22 </body>
23 </html>

```

Fig.19: Code to change background of text iteratively.

Fig.20: Repeated color change of text background

The whole table including headers and data cells is uniformly styled. Table borders, padding and alignment are managed by properties like `border`, `padding` and `text-align`; resulting in a well-organized layout. Every alternate row is given a different background color via the `nth-child(odd)` rule on line 18. This way all the odd numbered lines will have different background color.

On line 22, the `#footnote` rule applies styles including animation and font size to attribute having the ID "footnote". The "highlight" animation is defined by the `@keyframes highlight` rule on line 27, which changes the footnote's background color from translucent to yellow and back.

Now, let us add the animation style in the Doctor's appointment table in the form of a footnote.

The corresponding code is in Fig.21.

```
1  <!DOCTYPE html>
2  <html lang="en">
3  <head>
4    <title>Doctor's Visit Appointments</title>
5    <style>
6      table {
7        border: 2px solid lightgray;
8        border-collapse: collapse;
9      }
10     th, td {
11       padding: 10px;
12       text-align: left;
13     }
14     th {
15       background-color: lightblue;
16       color: white;
17     }
18     tr:nth-child(odd) {
19       background-color: gray;
20     }
21
22     #footnote {
23       font-size: 12px;
24       animation: highlight 2s ease-in-out alternate infinite;
25     }
26
27     @keyframes highlight {
28       from { background-color: transparent; }
29       to { background-color: yellow; }
30     }
31 </style>
```

```

32 </head>
33 <body>
34 <h1>Doctor's Visit Appointments</h1>
35 <table>
36 <caption>List of upcoming appointments</
caption>
37 <thead>
38 <tr>
39 <th>Patient Name</th>
40 <th>Date</th>
41 <th>Time</th>
42 <th>Doctor</th>
43 <th>Reason for Visit</th>
44 </tr>
45 </thead>
46 <tbody>
47 <tr>
48 <td>Adil</td>
49 <td>2024-05-10</td>
50 <td>10:00 AM</td>
51 <td>Dr. Shams</td>
52 <td>Follow-up</td>
53 </tr>
54 <tr>
55 <td>Zaki</td>
56 <td>2024-05-15</td>
57 <td>2:00 PM</td>
58 <td>Dr. Qamar</td>
59 <td>Check-up</td>
60 </tr>
61 </tbody>
62 <tfoot>
63 <tr>
64 <td colspan="5" id="footnote">* The
appointments may subject to change.</td>
65 </tr>
66 </tfoot>
67 </table>
68 </body>
69 </html>

```

Fig.21: Code to apply animated footnote to a table

OUTPUT

Doctor's Visit Appointments

List of upcoming appointments

Patient Name	Date	Time	Doctor	Reason for Visit
Adil	2024-05-10	10:00 AM	Dr. Shams	Follow-up
Zaki	2024-05-15	2:00 PM	Dr. Qamar	Check-up
* The appointments may subject to change.				

Fig.22: Animated footnote for a table

The footnote at the bottom of the table is highlighted as can be seen in Fig.22. “@keyframes highlight” rule as defined on line 27 is used for this animation property. For this a single table cell with the ID “footnote” spans over all the columns on line 64. Such highlighted footnotes are quite useful for projecting important information.

3.3 Advanced Programming Constructs in JavaScript

Conventional websites are static since they are only made with HTML and CSS. Every time a user visits the website, the same content is displayed. This configuration is sufficient for basic informative webpages; however, JavaScript is used to provide further interaction. Few reasons that sophisticated programming concepts is crucial when using JavaScript to create dynamic webpages are as follows:

Interactivity

User input such as clicks, scrolling, and form submissions are not supported by basic HTML. Writing code that responds to these events is made possible by JavaScript, which enhances the user interaction on the website. When a button changes color or a form verifies your data before submitting, such functionalities which manage user interaction are examples of JavaScript enhancement.



Fig.23: Sample webpage Interactivity via Touchscreen

DATA HANDLING



Fig.24: Sample data handling in the form of a pie chart

Data Handling

In order to show information about products or user comments, for example, websites frequently need to interact with data. Functions & loops are examples of ideas that help manage and change this data. For instance, you might use functions to carry out computations depending on user input or a loop to list things from a database and plot them in the form a graph .

Dynamic Content Updates

In the absence of JavaScript, modifying the content of a website requires a page refresh. Updates

to some sections of the website may be made without a page reload using JavaScript, which enhance user involvement and performance. For example a newsfeed that updates itself with new content without requiring you to click on a "refresh" button. This way, manual clicks are minimized for newer content updation.

Complex User Interfaces

Drop-down menus, picture slideshows, live chat and other such components are common on modern websites. This can only be accomplished via manipulating the webpage structure, using JavaScript. However at times, if the focus resides more on incorporating more and more features rather than the layout and navigation; it can result in redundancy. Hence, a complex user interface may arise as shown in



Fig.25: Sample content which are updated on a website

Fig. 26, where every option is accessible from main menu as well as side menu.

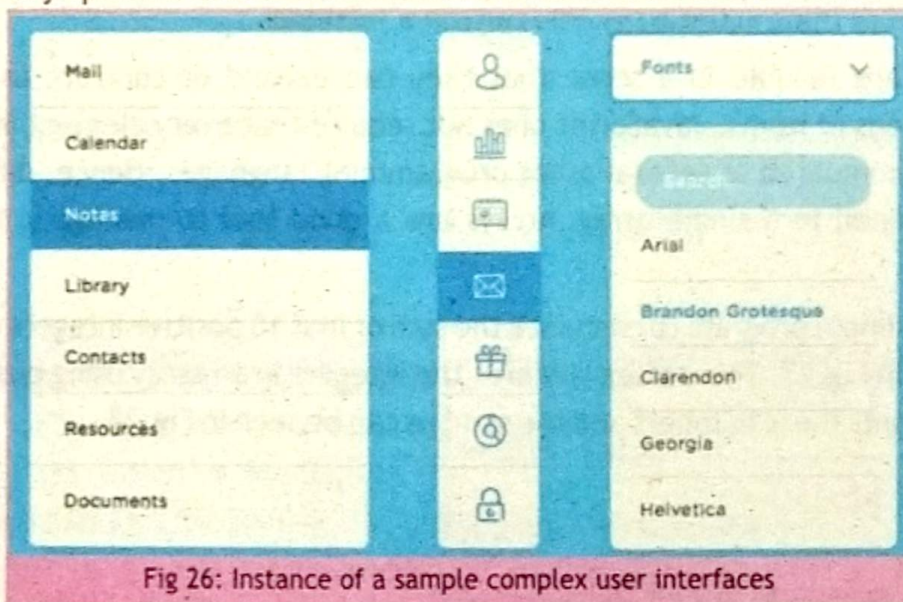

Fig 26: Instance of a sample complex user interfaces

3.3.1 Arrays in JavaScript

JavaScript arrays are a good way for organizing sets of similar data as they allow storing numerous values in a single container. For instance:

Let's say to store names of fruits, distinct variables for every fruit type will look like:

"apple" be fruit1, "banana" be fruit2, "orange" be fruit3, etc.

Alternatively, you may keep every fruit in a single variable by using an array. Creating an array will look like this:

```
const fruits = ["apple", "banana", "orange"];
```

A JavaScript array's index is used to access each element and starts at 0. This indicates that the index of the first element is 0, the index of the second element is 1, and so on. As stated above, our array is named 'fruits' and contains the words "apple", "banana" and "orange". Every object

has an index number where the object is placed in the array. First, "apple" is placed at index 0, followed by "banana" at index 1, then "orange" at index 2. In JavaScript, an array can store various types of data, such as alphabets, numbers or a combination of both.

To traverse elements of an array and if same operation needs to be applied on several components, loops are used. To demonstrate the use of loop that iterates through every item in the 'fruits' array and outputs the result to the console is as follows:

```
1. for (let i = 0; i < fruits.length; i++)
2. {
3.   console.log(fruits[i]);
4. }
```

OUTPUT	apple
	banana
	orange

Key points about arrays:

- You may use 'push()' to add more items to the end and 'pop()' to remove items from the end.
- Use 'length()' to find out how many items are in the array.
- To go through every thing in the array, you can use a 'for-loop'.

JavaScript arrays are flexible in a sense that they can expand or contract to accommodate additions or deletions of items. JavaScript does not require that every element in an array be of the same type, as compared to several other programming languages. Hence, different types of data can be combined in a single array. Arrays are a good tool to manage groups of data in JavaScript code.

Let us start with a simple program to calculate the sum of first 10 positive integers using a for-loop on line 13 as show in Fig. 27. Thereafter, it stores the integers in an array using push() function on line 15 and later prints these numbers and the sum; as can be seen in Fig. 28.

```
1 <!DOCTYPE html>
2 <html>
3 <head>
4   <title>Sum of First 10 Integers</title>
5 </head>
6 <body>
7
8 <script>
9   function calculateSum() {
10    let sum = 0;
11    let numbers = [];
12
13    for (let i = 1; i <= 10; i++) {
14      sum += i;
15      numbers.push(i);
16    }
```

Do you know?

In JavaScript, you can move around an object's structure by using the dot operator (.) for obtaining the parameters and methods of the object. Either to get the value of a property from an object (use the dot operator and then the name of the property) or to call a function.

```

17
18 document.getElementById("sumDisplay").textContent = "The sum of the
first 10 integers is: " + sum;
19
20 let output = "The first 10 integers are: [ ";
21 for (let i = 0; i < numbers.length; i++) {
22     output += numbers[i];
23     if (i < numbers.length - 1) {
24         output += ", ";
25     }
26 }
27 output += " ]";
28 document.getElementById("numberDisplay").textContent = output;
29 }
30 </script>
31
32 <button onclick="calculateSum()">Calculate Sum</button>
33 <br>
34 <p id="numberDisplay"></p>
35 <p id="sumDisplay"></p>
36
37 </body>
38 </html>

```

Fig.27: Program to calculate sum of first 10 positive numbers

On line 9, we define a function namely 'calculateSum()', in which a for-loop is executed starting from 1 till 10. On line 14, a variable 'sum' which has initial value of zero, is added with the index 'i'. This way, by the line the loop terminates, we will be having

the sum of all the ten numbers, stored in variable 'sum'. Noteable point is the next line where the index is stored in the array using push() function, which will always append (add to the existing) array value of 'i'.

Calculate Sum	OUTPUT
The first 10 integers are: [1, 2, 3, 4, 5, 6, 7, 8, 9, 10]	
The sum of the first 10 integers is: 55	

Fig.28: Sum of first 10 numbers using array



Activity-3

Change the code of Fig.27 for the following output:

Calculate Sum
The <u>next</u> 10 integers are: [11, 12, 13, 14, 15, 16, 17, 18, 19, 20]
The sum of the <u>next</u> 10 integers is: 155

```

1 <!DOCTYPE html>
2 <html lang="en">
3 <head>
4   <title>Shopping List</title>
5   <style>
6     table {
7       border-collapse: collapse;
8       width: 100%;
9     }
10    th, td {
11      padding: 10px;
12      border: 1px solid lightgray;
13      text-align: left;
14    }
15  </style>
16 </head>
17 <body>
18   <h1>My Shopping List</h1>
19   <input type="text" id="newItem" placeholder="Enter item name">
20   <button onclick="addItem()">Add Item</button>
21   <br>
22   <table id="shoppingListTable"></table>
23
24   <script>
25     let shoppingList = [];
26
27     function addItem() {
28       const newItemName = document.getElementById
29         ("newItem").value;
30
31       if (newItemName !== "") {
32         shoppingList.push(newItemName);
33
34         document.getElementById("newItem").value = "";
35
36         updateShoppingListTable();
37       } else {
38         alert("Please enter an item name!");
39       }
40
41     }
42
43     function updateShoppingListTable() {
44       const table = document.getElementById
45         ("shoppingListTable");

```

```

43
44 table.innerHTML = "";
45
46 const headerRow = document.createElement("tr");
47 const headerItem = document.createElement("th");
48 headerItem.textContent = "Shopping List Items";
49 headerRow.appendChild(headerItem);
50 table.appendChild(headerRow);
51
52 for (let i = 0; i < shoppingList.length; i++) {
53     const itemRow = document.createElement("tr");
54     const itemCell = document.createElement("td");
55     itemCell.textContent = shoppingList[i];
56     itemRow.appendChild(itemCell);
57     table.appendChild(itemRow);
58 }
59 }
60 </script>
61 </body>
62 </html>

```

Fig.29: Program to add items in a shopping list

OUTPUT

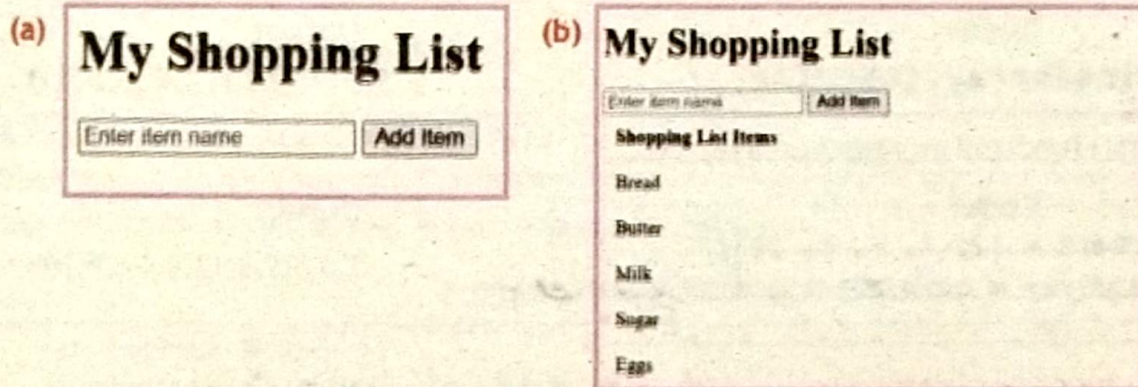

Fig.30: Shopping list

The next code of Fig.29 shows how to use a JavaScript array to handle a shopping list. The array keeps track of the item names and the functions in the code handling of adding new items and updating the list on the webpage automatically.

The webpage has a heading, an add-item button, a text box where you may write the products and a table that shows your shopping list.

We maintain the list using JavaScript, as:

The items are being added in an array we call "shoppingList".

The "addItem()" function is activated upon clicking the "Add Item" button which checks to see if the box has entered text that is then added to the "shoppingList" and the box is cleared to be rewritten.

- After that the new item is then shown in the table by using a different function called "updateShoppingListTable()".
- Additionally, a top row labeled "Shopping List Items" also is visible.
- Lastly, it adds each item to a new row in the table by going through the "shoppingList" one by one. In this manner, any chosen item to be purchased is added to the table.

The respective output is shown in Fig. 30.

The major functions associated with arrays in JavaScript are:

- Push() function adds the value at the end of the array. In the following code, initially an array is created and later another value is inserted using the push() function that appends at the end.

Code:	Output:
<code>oddNumbers = [1, 3, 5, 7, 9];</code>	Initial array: 1,3,5,7,9
<code>oddNumbers.push(11);</code>	After push(11): 1,3,5,7,9,11

- IndexOf() function searches for and locates the given element in an array. If present, it returns the index number where the said element resides. For instance:

Code:	Output
<code>oddNumbers.indexOf(11);</code>	Index of last added number (11): 5

- ToString() function when applied to an array, converts all the elements of the array into a single string, such that elements are separated by commas. Such as:

Code:	Output:
<code>combinedArray.toString();</code>	1,3,5,7,9,11,2,4,6,8,10

- Concat() function merges 2 arrays, like:

Code:	Output:
<code>evenNumbers = [2, 4, 6, 8, 10];</code>	1,3,5,7,9,11,2,4,6,8,10
<code>combinedArray = oddNumbers.concat(evenNumbers);</code>	

- Slice() function creates a new subset array of the original array. For example:

Code:	Output:
<code>oddNumbers.slice(2, 4);</code>	Slice of 2 consecutive numbers: 5, 7

3.3.2 Bullet Points in HTML

Recall that, you may create lists with bullet points in HTML in two major ways:

- Unordered List ():

Lists with bullet points that often resemble squares, circles, or other symbols fall under this category.

- Ordered List ():

Lists with bullet points that are numbers (1, 2, 3, etc.) in order fall under this category.

Now, let's modify the doctor appointment example to use an unordered list and incorporate several pricing packages. The code is shown in Fig .31.

```
1 <!DOCTYPE html>
2 <html lang="en">
3 <head>
4   <title>Doctor's Visit Appointments</title>
5   <style>
6     table {
7       border: 2px solid black;
8       border-collapse: collapse;
9     }
10    th, td {
11      padding: 10px;
12      text-align: left;
13    }
14    th {
15      background-color: lightblue;
16      color: white;
17    }
18    tr:nth-child(odd) {
19      background-color: lightyellow;
20    }
21  </style>
22 </head>
23 <body>
24   <h1>Doctor's Visit Appointments</h1>
25   <table>
26     <caption>List of upcoming appointments</caption>
27     <thead>
28       <tr>
29         <th>Patient Name</th>
30         <th>Date</th>
31         <th>Time</th>
32         <th>Doctor</th>
33         <th>Reason for Visit</th>
34       </tr>
35     </thead>
36     <tbody>
37       <tr>
38         <td>Adil</td>
39         <td>2024-05-10</td>
40         <td>10:00 AM</td>
41         <td>Dr. Shams</td>
42         <td>Follow-up</td>
43       </tr>
```

1
2
3
4
5
6
7
8
9
10
11
12
13
14
15
16
17
18
19
20
21
22
23
24
25
26
27
28
29
30
31
32
33
34
35
36
37
38
39
40
41
42
43
44
45
46
47
48
49
50
51
52
53
54
55
56
57
58
59
60
61
62
63
64
65
66
67
68
69
70
71
72
73
74
75
76
77
78
79
80
81
82
83
84
85
86
87
88
89
90
91
92
93
94
95
96
97
98
99
100

```
<table border="1">  
<thead>  
<tr>  
<th>Name</th>  
<th>Year</th>  
<th>Date</th>  
<th>Time</th>  
<th>Reason for Visit</th>  
</tr>  
</thead>  
<tbody>  
<tr>  
<td>Dr. A</td>  
<td>2016</td>  
<td>10/10/16</td>  
<td>12:30 PM</td>  
<td>Follow-up</td>  
</tr>  
<tr>  
<td>Dr. B</td>  
<td>2016</td>  
<td>11/20/16</td>  
<td>12:00 PM</td>  
<td>Check-up</td>  
</tr>  
</tbody>  
</table>  
  
<table border="1">  
<thead>  
<tr>  
<th colspan="2">Fee Packages</th>  
</tr>  
</thead>  
<tbody>  
<tr>  
<td colspan="2"><ul style="list-style-type: none;">  
<li>• Standard Consultation: $1,500</li>  
<li>• Follow-up Visit: $1,000</li>  
<li>• Comprehensive Check-up: $1,200</li>  
</ul></td>  
</tr>  
</tbody>  
</table>
```

Fig. 21: Code to add fee packages in bullet points

OUTPUT

Doctor's Visit Appointments

Use of opening appointments

Name	Year	Date	Time	Reason for Visit
Dr. A	2016	10/10/16	12:30 PM	Follow-up
Dr. B	2016	11/20/16	12:00 PM	Check-up

* This table displays a sample list of appointments.
* Fee Packages:

- Standard Consultation: \$1,500
- Follow-up Visit: \$1,000
- Comprehensive Check-up: \$1,200

Fig. 22: Fee package in bullet points

Teacher Guide

The colors can either be used for their respective reason for visit or can be used. For example, the color 'Lightblue' can be used for the header. A detail link can be found at <https://htmlcolorcodes.com/>

The footnote portion of the page is updated and clearly highlights the fee packages. For this, line 52. Earlier code is unchanged. An unordered list (bullet points) may now be found in the footnote on line 57. In this list, each fee package is represented by a list item (). A line break (
 tag) is inserted between the phrase "Fee Packages," and the list items. This makes it easier to read and helps in understanding the content, as shown in Fig. 22.

3.3.3 Bullet Points can be Values from Arrays

The next example demonstrates how to create dynamic web page features with JavaScript and arrays. The code creates a simple shopping list to which users may add new items. The 'shoppingItems' JavaScript array contains the list of items. The content of the array is used by the updateList() method to create list. Any modifications made to the array are therefore reflected in the list. The code is shown in Fig. 33.

```
1 <!DOCTYPE html>
2 <head>
3   <title>Shopping List</title>
4 </head>
5 <body>
6   <h1>My Shopping List</h1>
7   <ul id="shoppingList"></ul>
8   <script>
9     const shoppingItems = ["Milk", "Bread", "Eggs", "Apples"];
10
11    function addItem() {
12      const newItem = document.getElementById("newItemInput").value;
13      shoppingItems.push(newItem);
14      updateList();
15    }
16
17    function updateList() {
18      const listElement = document.getElementById("shoppingList");
19      listElement.innerHTML = "";
20
21      for (let i = 0; i < shoppingItems.length; i++) {
22        const item = shoppingItems[i];
23        const listItem = document.createElement("li");
24        listItem.textContent = item;
25        listElement.appendChild(listItem);
26      }
27    }
28    updateList();
29  </script>
30  <br>
31  <input type="text" id="newItemInput" placeholder="Enter new item">
32  <button onclick="addItem()">Add Item</button>
33 </body>
34 </html>
```

Fig.33: Code to display array contents in bullet points

(a)

My Shopping List

(b)

My Shopping List

- Milk
- Bread
- Eggs
- Apples

Fig.34: Shopping list items in bullet points

As can be seen in Fig. 34, the webpage has a heading "My Shopping List", an empty list that displays the items in bullet points and a box where you can enter additional items and an 'add item' button. The "shoppingItems" list defined on line 9 in this code maintains record of all that we add. The "addItem" function is activated upon clicking the "Add Item" button. The text we entered in the box is added to the "shoppingItems" list by this function. The "updateList" method on line 17 is then called in order to ensure that the new item is displayed in our list on the webpage.

A block of code which is repeatedly used for a particular operation is called a function. A function may be defined once and called several times in the program which simplifies code and decreases lines-of-code. When defining a function the `function` keyword is used followed by the name of the function and parenthesis for any input parameters.

The code for the function is enclosed in curly brackets. The function "updateList" locates every item on the web page and removes any content that is already there. Subsequently, it iteratively moves through the "shoppingItems" list, converting each item to a bullet point and appends it to the list displayed on the website. In this way any purchase is constantly added to the list.

3.4 Complex Algorithms in JavaScript

3.4.1 Array & List are Similar

An ordered sequence of elements is called list. A list is an Abstract Data Type (ADT), where an ADT is the data type which acts for defined operations only. In simple words, though JavaScript provides some basic data types to use but allows to introduce newer data types that are abstract, for which the definition and corresponding operations need to be explicitly mentioned.

Arrays and lists are JavaScript data structures that can hold and manage collections of data. Lists and arrays may both arrange things in an ordered fashion for a set of elements. Every element is stored and accessed via an index number which starts at 0 which shows its position. Based on this index number, values can be searched for and updated if required.

Both are able to hold all types of data, i.e. an array or list can include words, numbers or even a combination of the two. Both are able to expand or contract to hold items, since adding or removing of items as required is quite easy. In simplest form, list is implemented using array.

Major Differences:

- Array is a collection of items, that are stored in memory at contiguous location, whereas list consists of memory locations that are not necessarily contiguous.
- Square brackets [] indicate that an array is a built-in JavaScript tool. Lists are not a component of JavaScript. Tools like arrays are frequently used to create them.
- Since arrays have a fixed arrangement, adding or deleting elements may require some rearranging. Based on how they are constructed, lists can be resized more easily.
- The functions of Arrays are already available, such as to add and remove an item. Lists may need additional steps and are flexible enough to incorporate newer functions and operations. For example, we can define a function 'getElement()' to view the value of current element.
- Arrays are best suited for working with numbers, while lists are chosen for general usage.

Selecting Among Lists and Arrays:

Arrays are a great option for the majority of simple JavaScript tasks since they are simple to use. However, if you want something more versatile, lists are more suitable.

3.4.2 Find an Element in a List

The standard procedure is to search the entire list until you locate the item you're looking for. Here's a basic example that demonstrates how it works. Initially, every item in the "Shopping List" list is shown i.e. bread, apples, milk, and cheese. Thereafter it searches for a certain item (like "milk") and indicates in the "Result" whether or not it is included in the list.

The shopping list's algorithm and how it finds a certain item is as:

Algorithm

1. Initialize:

- To store shopping goods, create an array called shoppingList.
- listContent (string): This is how the shopping list is put together for presentation.
- The item to be searched for is held in itemName (string).

2. Enlisting Shopping List (the initial Loop):

- Iterate shoppingList array using a loop.

3. Within the loop:

- Update the listContent string with the current item.
- If this is not the final item, separate it with a comma and leave space.
- Using the entire listContent string, update the HTML section with the ID "list".

4. The second loop:

- (a) search for an item by going over everything in the shoppingList array.
- (b) Inside loop: Verify that the item we now have matches the itemName that we are searching for.
- (c) If a match is discovered, use return to end the loop and update the HTML section with the ID "result" and a message indicating the item is found.
- (d) Update the HTML code in the section with the ID "result" with a notification indicating the item is not found if the loop concludes without finding a match.

5. Using the Algorithm:

- (a) To begin, call the findItem method and search the required itemName.

The respective implementation of the algorithm is as follows:

```
1 <!DOCTYPE html>
2 <html lang="en">
3 <head>
4   <title>Finding Element in Array</title>
5 </head>
6 <body>
7   <h1>Shopping Cart</h1>
8   <p id="list"></p>
9   <p id="result"></p>
10
11 <script>
12   const shoppingList = ["apples", "bread", "milk", "cheese"];
13   function findItem(itemName) {
14     let listContent = "Shopping List: ";
15
16     for (let i = 0; i < shoppingList.length; i++) {
17       listContent += shoppingList[i];
18       if (i < shoppingList.length - 1) {
19         listContent += ", ";
20       }
21     }
22     document.getElementById("list").textContent = listContent;
23     for (let i = 0; i < shoppingList.length; i++) {
24       if (shoppingList[i] === itemName) {
25         document.getElementById("result").textContent = `${itemName}
26         is in your shopping list!`;
27         return;
28       }
29     }
30   }
31 }
```

```

29     document.getElementById("result").textContent = `${itemName} is
       not in your shopping list.`;
30     }
31     findItem("milk");
32 </script>
33 </body>
34 </html>

```

Fig.35: list-1.html

The program of the above algorithm is shown in Fig.35:

- A shopping-list array with some items is created in line 12.
- On line 13 function 'findItem()' is defined which takes an 'itemName' as an argument and searches for a certain item within the array.
- Next, on line 16 using a for-loop every item in the shopping list is traversed and a string is constructed and printed on line 22.
- Thereafter, the loop on line 23 searches for the respective item, if the item is found then the result is updated as shown in Fig. 36.
- Otherwise a message is displayed on line 29 informing the user that the said item was not found in the list.

OUTPUT

Shopping Cart

Shopping List: apples, bread, milk, cheese

"milk" is in your shopping list!

Fig.36: list-1.html



Activity-6

Design an algorithm which displays a list of 10 courses offered, and allows user to search for a course.

The webpage output in Fig.36 has undergone minor modifications. There are now two paragraphs.

- First one is the list which displays the whole shopping list. Additionally, a new paragraph displays any search results. We created a new variable named "listContent" on line 14 to do this. All the goods on your shopping list are kept in what looks like a box.
- Next, each item on your list was added to the "listContent" list by means of a loop on lines 16-20. To make it simpler to read, we put commas in between each item. The "list" is updated using its entire "listContent" list after the loop is complete on line 22.

The process of searching for any item remains unchanged. However, we are now searching the shopping list with another loop to find the item in the list.

3.5 Advanced techniques for testing and debugging

3.5.1 Unit Test

In software development, unit test is a crucial activity to ensure that every module of code functions properly, i.e. the code performs as desired. Unit tests are intended to test each line of code to make sure it functions properly. Error detection at an early stage is critical to prevent more serious issues in the later stages.

Unit test also help in outlining function of every section of code. This makes it easier for developers to understand and maintain their code. If the unit tests continue to pass, you may be certain that the primary functionality will continue to function even after you make significant modifications or rearrange the code.

Unit test can be applied to a function, a module or even to a single line of code. For instance, a mathematical formula is to be incorporated to calculate Zakat of yield from an agriculture land. So, the written formula needs to be tested by the developer for different values based on different possible scenarios; till this line of code passes multiple unit tests. Hence, unit tests ensure the quality of code, by providing developers the confidence in making changes, identify errors early and facilitate code management.

Two test cases are presented in Fig.37, for the code of shopping list example of Fig.33. Test 1 looks for the object "milk," which we know exists and anticipates that the function will return "true." Test 2 looks for the nonexistent object "eggs" and anticipates a "false" response from the method. The tests' outcomes are displayed in the Fig.38 based on the return value of the 'findItem' method. The website layout is mostly unchanged, with a title and a paragraph displaying the unit test results. For the sake of simplicity, the 'findItem()' method is not modified in this example.

```
1 <!DOCTYPE html>
2 <html lang="en">
3 <head>
4   <title>Unit Tests for Array Search</title>
5 </head>
6 <body>
7   <h1>Unit Tests for 'findItem' function</h1>
8   <p id="testResults"></p>
9   <script>
10    const shoppingList = ["apples", "bread", "milk", "cheese"];
11
12    function findItem(itemName) {
13      for (let i = 0; i < shoppingList.length; i++) {
14        if (shoppingList[i] == itemName) {
15          return true;
16        }
17      }
18    }
19  </script>
20 </body>
21 </html>
```

```

17     }
18     return false;
19 }
20
21 let testResults = "";
22 testResults += "Test 1 (Existing Item): ";
23 ✓ if (findItem("milk") == true) {
24     testResults += "Passed \n";
25 } else {
26     testResults += "Failed \n";
27 }
28 testResults += "\n Test 2 (Non-Existing Item): ";
29 ✓ if (findItem("eggs") == false) {
30     testResults += "Passed\n";
31 } else {
32     testResults += "Failed\n";
33 }
34 document.getElementById("testResults").textContent = testResults;
35 </script>
36 </body>
37 </html>

```

Fig. 37: Code with unit test

OUTPUT

Unit Tests for `findItem` Function

Test 1 (Existing Item): Passed

Test 2 (Non-Existing Item): Passed

Fig.38:Unit Test-1.html

3.5.2 Debugging Allows to Analyze the Code

Debugging is useful as:

- Debugging identifies flaws in the code that might affect the layout or functionality of your webpage.
- Debugging allows you to observe step-by-step operation of your code.
- You may create your website more quickly by identifying and rectifying mistakes right away.

Debugging techniques in IDE like Visual Studio.NET involve mainly:

Breakpoint:

Assume you are monitoring a certain line of code where you think that something is dubious. The application pauses at breakpoints and allows you to examine the code (variable values, data flow, etc.).

Watchpoint:

In a watchpoint, you establish a rule (for example, whether the value is utilized or changed) on variables or expressions. The software pauses at that particular watchpoint if the rule is followed.

Breakpoints and watchpoints can indicate issues in the code that may be affecting the functionality of your website by highlighting issues and errors.

Let us consider the already discussed example of summing up first 10 integers.

- We have incorporated a bug for the sake of discussion in the for-loop on line 13, in Fig.39. Such things happen unintentionally like typing errors, etc.
- Since, the desired values were not being achieved, so we deployed a breakpoint and added the next 2 lines as watchpoints. Thereafter, we ran the code in debug mode and 'Step-Over' for line by line execution.
- As the loop started, the value of 'i' is shown as 10 in the function block section under variables heading (marked as blue square) and same was the value of 'sum' in watch section (green rectangle).

```
1 <!DOCTYPE html>
2 <html>
3 <head>
4   <title>Sum of First 10 Integers</title>
5 </head>
6 <body>
7
8 <script>
9   function calculateSum() {
10    let sum = 0;
11    let numbers = [];
12
13    for (let i = 10; i <= 10; i++) {
14      sum += i;
15      numbers.push(i);
16    }
17
18    document.getElementById("sumDisplay").textContent =
19    "The sum of the first 10 integers is: " + sum;
20
21    let output = "The first 10 integers are: [ ";
22    for (let i = 0; i < numbers.length; i++) {
23      output += numbers[i];
```

Fig.39: Code with bug

So, the bug was identified and fixed, as shown in next Fig.40.

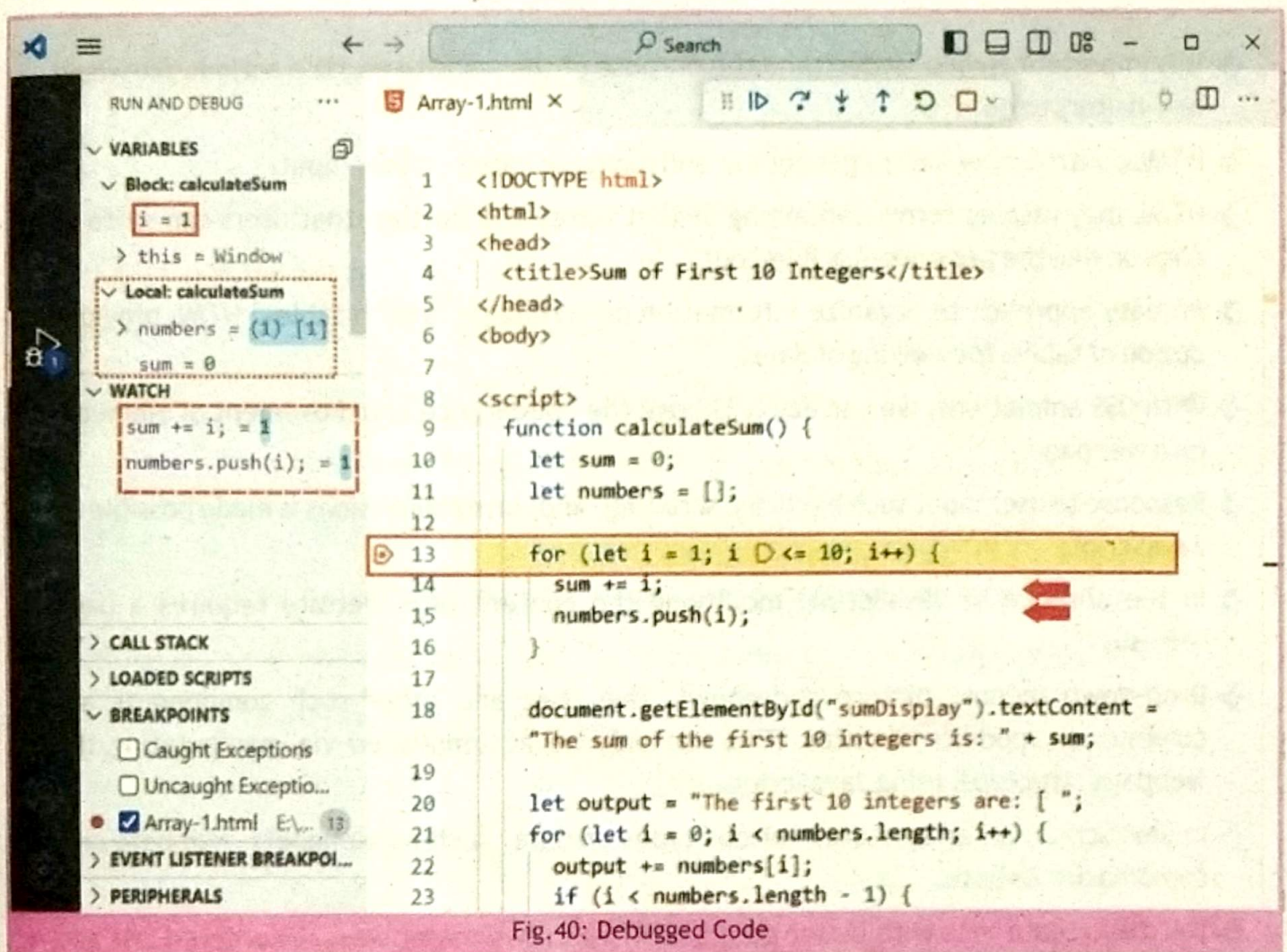

Fig.40: Debugged Code

Mini Project-1

Write code to take initially 2 arrays with 5 numbers each, as follows:

- Arr1 = [1, 3, 5, 7, 9]
- Arr2 = [2, 4, 5, 6, 8]

Check every number in the first array against every number in the second array. Display result for each number of the first array whether it was found in the second array or not. Lastly, add 2 unit tests in it by providing the numbers for:

- Check for common elements in both arrays.
- Check for uncommon elements with respect to Arr1, i.e. the numbers which are present in Arr1 but not in Arr2.

Mini Project-2

Create a list such that through buttons, the following operations are executed:

- Create List
- Find Number
- Total Numbers in List
- Insert Number
- Remove Number
- Print List

Whenever a button is pressed, corresponding function should be called.

You may use alerts for user input where necessary, as shown in figure.

List Operations

Create List Insert Number Find Number Remove Number Get Total Numbers Print List

List: 25, 52, 35, 53, 45, 54

Unit Summary

- It is important to first understand the purpose of the website and the actions you would like visitors to do.
- HTML controls how web pages appear and navigate based on user input.
- HTML may display forms containing text boxes and buttons that users can write or click on like the paperwork is filled out.
- An easy approach to organize information on webpages is with tables. HTML provides option of tables for viewing of data.
- With CSS animations, we can easily change the appearance and movement of elements on a webpage.
- Response to user input such as clicks, scrolling, and form submissions is made possible by JavaScript.
- In the absence of JavaScript, modifying the content of a website requires a page refresh.
- Drop-down menus, picture slideshows, live chat and other such components are common on modern websites. This can only be accomplished via manipulating the webpage structure, using JavaScript.
- In JavaScript, an array stores various types of data, such as alphabets, numbers or a combination of both.
- You may create lists with bullet points in HTML in two major ways, Unordered List and Ordered List.
- Array is a collection of items, that are stored in memory at contiguous location, whereas list consists of memory locations that are not necessarily contiguous.
- Unit tests are intended to test each line of code to make sure it functions properly. Error detection at an early stage is critical to prevent more serious issues in the later stages.
- To monitor a certain line of code, the application pauses at breakpoints and allows you to examine the code (variable values, data flow, etc.).
- In a watchpoint, you establish a rule (for example, whether the value is utilized or changed) on variables or expressions. The software pauses at that particular watchpoint if the rule is followed.

Exercise

Q1. Select the best answer for the following MCQs.

- Which of the following is primarily associated with front-end development?
 - Server management
 - Database design
 - User interface and design
 - Memory Management
- Which of the following HTML attributes is required in the `<input>` element for email?
 - `type="url"`
 - `type="text"`
 - `type="email"`
 - `type="password"`
- In JavaScript, which method would you use to add a new item to the end of a list?
 - `push()`
 - `add()`
 - `leftshift()`
 - `rightshift()`
- In JavaScript, how do you access the third element in an array called `myArray`?
 - `myArray[3]`
 - `myArray[2]`
 - `myArray[1]`
 - `myArray[0]`
- To manually stop JavaScript code execution at a certain point, you can use:
 - `console.log()`
 - `stop`
 - `break`
 - debugger
- What is the primary purpose of unit tests?
 - To validate code syntax
 - To test individual parts of the code for correctness
 - To style the user interface
 - To deploy code to production
- Front end development is also called _____.
 - Label
 - Client-side
 - Server
 - Database
- Table is an easy way to organize information in _____.
 - columns
 - rows
 - webpages
 - list
- Table's header cell and content is referred in _____ tag.
 - `<th>`
 - `<td>`
 - `<caption>`
 - `<tr>`
- Link between the borders of neighboring table cell is determined by _____.
 - Link border
 - border collapse
 - border separate
 - border

11. Distance between the cell's border and its content is called _____.

- a) Cell b) Output c) Padding d) Style

12. An element style during animation is specified by _____.

- a) @key frame b) @style frame c) @highlighted frame d) @anchor frame

13. A single table cell is indicated by a _____ tag.

- a) <tc> b) <tf> c) <td> d) <th>

14. Arrays and list can contain data types containing _____.

- a) Alphabets b) Numbers c) Alphanumeric d) Checkboxes

15. ADT stands for _____.

- a) Abstract Data type b) Abstract document type
c) All Data type d) Any Data type

Q2. Give short answers to the following Short Response Questions (SRQs)

1. Give an example where back-end development may not be required and all of the functionalities are handled by front-end.

2. What are the 'td', 'th' and 'tr' tags used for? Explain with the help of an example.

3. Find error(s) in the following codes.

```
1 <!DOCTYPE html>
2 <html>
3 <head>
4   <title>Bug in Array</title>
5 </head>
6 <body>
7   <h1>Find the Bug</h1>
8   <script>
9     const myArray = ("apple", 3.14,
10    true, "orange");
11    document.write(`<p>My Array: $
12    {myArray[1]}</p>`);
13  </script>
14 </body>
15 </html>
```

(a)

```
1 <!DOCTYPE html>
2 <html>
3 <head>
4   <title>Bug in the Array</title>
5 </head>
6 <body>
7   <h1>Hunt the Bug</h1>
8   <script>
9     const myArray = "apple", 3.14,
10    true, "orange";
11    document.write(`<p>My Array: $
12    {myArray}</p>`);
13  </script>
14 </body>
15 </html>
```

(b)

```

1 <!DOCTYPE html>
2 <html>
3 <head>
4   <title>Bug in Array & Loop</title>
5 </head>
6 <body>
7   <h1>Numbers are Bugged</h1>
8   <script>
9     const numbers = [1, 2, 3, 4, 5];
10    let output = "";
11    for (i = 0; i <= numbers.length; i++)
12    {
13      output += numbers[i] + " ";
14    }
15    document.write("<p>" + output + "</p>");
16  </script>
17 </body>
18 </html>

```

(c)

```

1 <!DOCTYPE html>
2 <html>
3 <head>
4   <title>Bugs in Array & Loop</title>
5 </head>
6 <body>
7   <h1>Bugs in Numbers </h1>
8   <script>
9     const numbers = [1, 2, 3, 4, 5];
10    let output = "";
11    for (i = numbers.length; i < 0 ; i--)
12    {
13      output += "<p>Number: $
14      {numbers[i]}</p>";
15    }
16    document.write(output);
17  </script>
18 </body>
19 </html>

```

(d)

4. How is unit testing used when adding a function to an already written program?
5. Enlist 3 key differences between array and list.
6. How are breakpoints useful in debugging? Elaborate with help of an example.

Q3. Write answers of the following extended response questions in the form of code.

1. For a Bakery, design a simple HTML form to take order online, which includes:

- ▶ radio buttons for the option of home delivery or self-collection,
- ▶ drop down list for 3 sizes of the cake,
- ▶ check boxes for candles, balloons, etc.
- ▶ Lastly, add a submit button which generates either an alert or redirects to another form; and responds with an order number.

Sample output is shown as follows:

Order Your Delicious Cake

Delivery or Pickup?

Home Delivery Self Pickup

Choose Your Cake Size:

Small (serves 4-6) ▾

Extra Delight (Check all that apply)

- Chocolate Chips
- Fresh Strawberries
- Rainbow Sprinkles

Extras:

- Birthday Candles
- Colorful Balloons

Place Order

file://

Your order has been submitted! Order number: 25061

Don't allow this site to prompt you again

OK

2. Design a website titled "My Weekly Evening Schedule", as follows:

My Weekly Evening Schedule

Day	Activity
Monday	Karate Class
Tuesday	Calligraphy Lessons
Wednesday	Math Test
Thursday	Gardening
Friday	Programming Practice

3. (a) Write code to display the following table:

My Favorite Fruits

Fruit Name	Color
Apple	Red
Banana	Yellow
Orange	Orange

g) Now change the table appearance as follows:

Fruit Name	Color
Apple	Red
Banana	Yellow
Orange	Orange

Write code for:

A colored text which repeatedly vanishes for a second and appears in the next second, giving the impression of a "blinking text"

An image, which spins a whole circle, waits for one second and spins again, in an iterative manner.

Sample output is as follows:

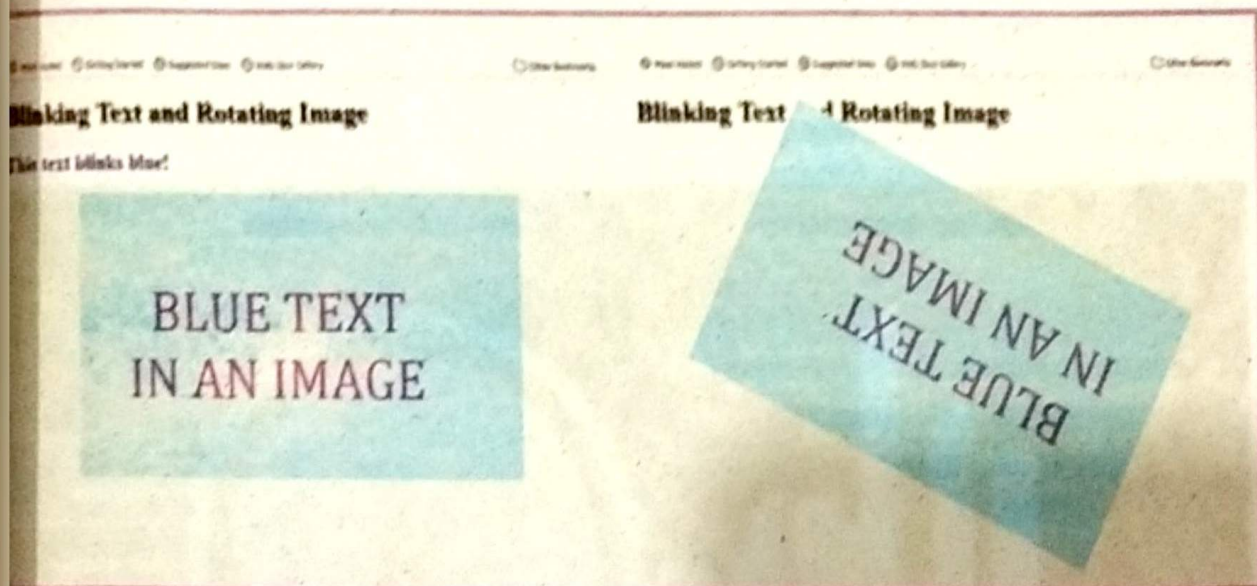

Write code to change the bullets into ordered list for the program 'Sum of first 10 integers'.

Create an array with the following values and print it as follows:

```
My_Mix_Array : [ apple, 3.14, true, Ali, 25 ]
```

A list contains 10 entries and we want to search a particular value in the list. Write code, to determine how many iterations it took:

- If the list is found in the list
- If the list is not found in the list



Learning Outcomes

At the end of this unit students will be able to:

- understand and explain the scope of data science, Artificial Intelligence (AI), and Machine Learning (ML), including types of supervised and unsupervised learning models, and their applications to common real-world problems.
- understand and explain the types, uses, and methods of data visualizations and understand the benefits of visualizing data.
- to apply stages of the data science life cycle e.g. understanding a real-world business problem, data gathering, building model, interpreting results).

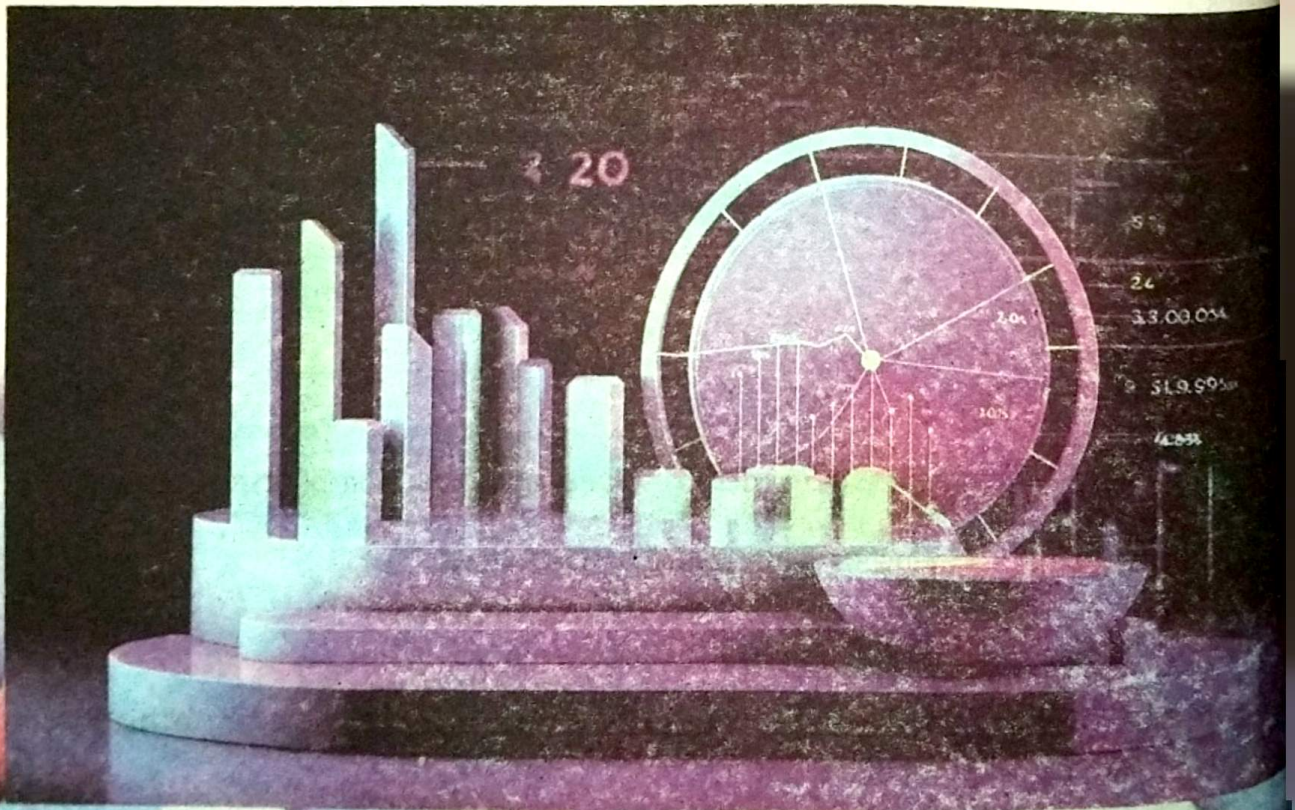

Introduction

Data science is a branch of knowledge, which joins together mathematics and statistics skills with the programming domain of computer science. This combination is useful in various fields of life e.g. if we want to predict the result of a football match, data science will help us. Currently, in the age of artificial intelligence, organization of available data into meaningful form is necessary, Data Science helps us to achieve the objective of getting insight from the data. Consequently, we can find optimized solutions along with predictive modeling. In the previous grade we learned some basic concepts about data science. Now, we will learn some advanced topics based on our previous knowledge.

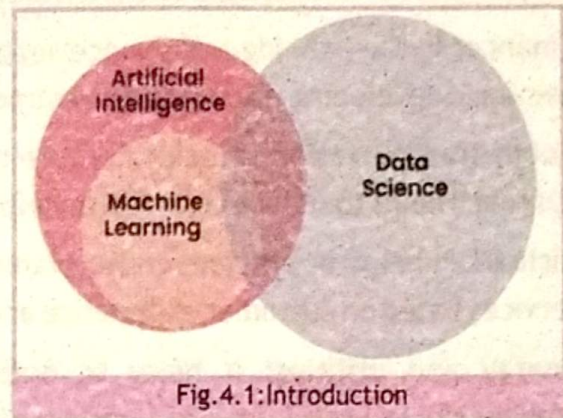

Fig.4.1:Introduction

4.1 Data Science

Data Science refers to an interdisciplinary field of mathematics, statistics, and computer science. Main objective of data science techniques is to get meaningful insight from the available data. The available data can be structured as well as unstructured. This objective is achieved through the steps of data collection, data cleaning, data preprocessing and data visualization. Various programming languages like Python, R studio and MATLAB can be used for data visualization.

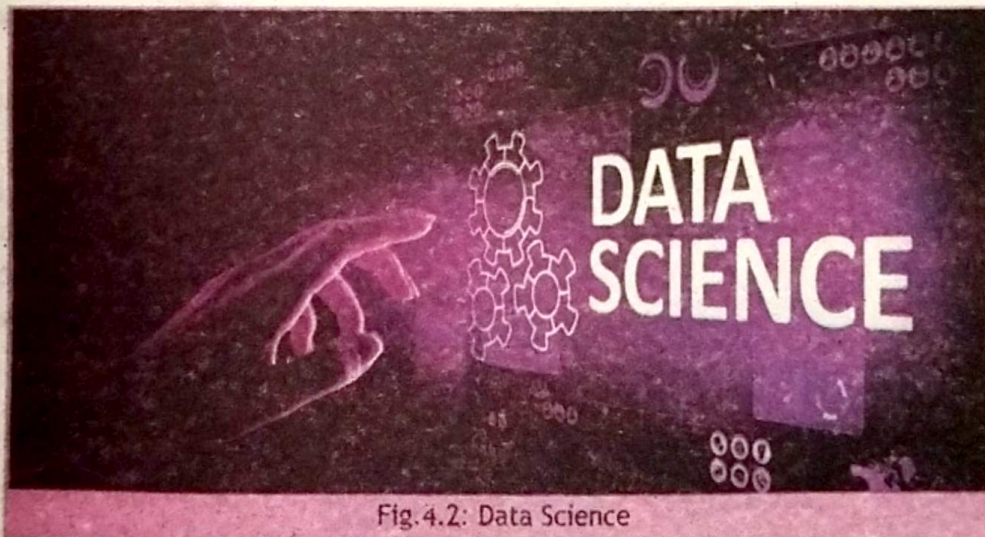

Fig.4.2: Data Science

4.1 Data Science and its scope

Data Science has wide scope in many disciplines of life and it is continuously expanding. We can learn about its scope in some common fields of life as follows:

Healthcare: To predict the possibilities of some disease, based on X-Rays, Ultrasounds or other diagnostics of patient.



Sports: If we want to predict who is going to win a cricket match, based on the previous performance of teams, data science will help us.

Finance: In the banking and finance sector, data science is helpful in fraud detection. It is also helpful in developing trading and investment strategies.

Goods transportation: It helps in route optimization and minimize delivery times. Data driven approach helps to reduce cost. It also helps in real time tracking of transportation of goods.

Airline: It helps in efficient route planning to reduce fuel consumption. It helps to improve services based on customer experience and feedback.

Energy and utilities: It helps to optimize energy production and distribution. Realtime monitoring is useful for load distribution and facilitates immediate response for demand fluctuations.

Education: It is useful to enhance personalized learning based on the performance of learners. It also helps to predict students' performance based on previous data.

Communication Media: It is used for content creation and distribution. Various approaches like sentiment analysis, social media monitoring and recommender systems are a few examples of scope of data science in media and communication sector.

Entertainment: Data science plays important role when you get suggestions about your favorite songs while playing online computer games.

Business: Data science helps in intelligent decision making about the business to get optimal profits. Customer insight and sentiments are also analyzed to improve the business.

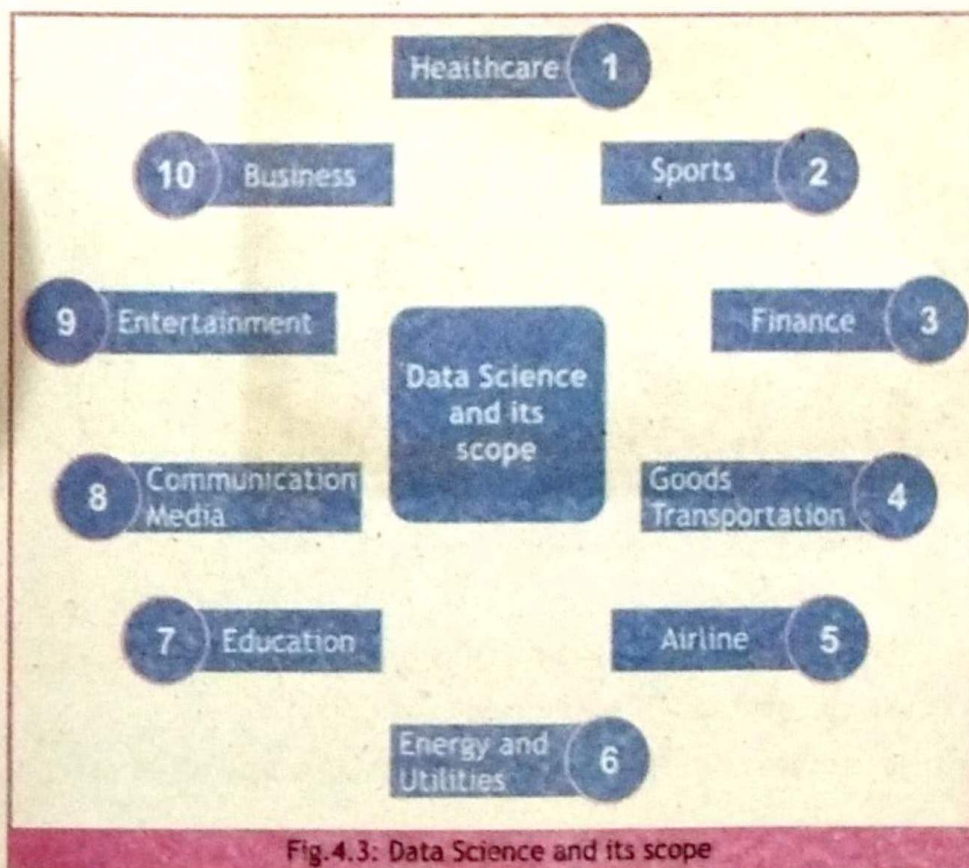

Fig.4.3: Data Science and its scope



DO YOU KNOW?

A recommender system is a tool or technology. It is used to recommend products, services or information to the user based on their past behavior and interests.



DO YOU KNOW?

Sentiment analysis is the term used to identify the sentiments of a customer by analyzing the review about the product. The sentiment can be positive, negative, or neutral. Sentiment analysis can be performed on reviews, text, opinions etc.

4.1.2 Artificial Intelligence and its scope

The term artificial intelligence is not new. In 1950 a British mathematician Alan Turing proposed a Turing Test, which measured the ability of machine to exhibit intelligent behavior. Now a days the modern robots are supposed to be smarter if they can pass the Turing Test. The term Artificial Intelligence is referred to the ability of a machine to exhibit human behavior like problem solving, understanding natural language and interacting with the environment intelligently.

Like data science, the scope of artificial intelligence is wide. Here, we can discuss a few of them as follows:

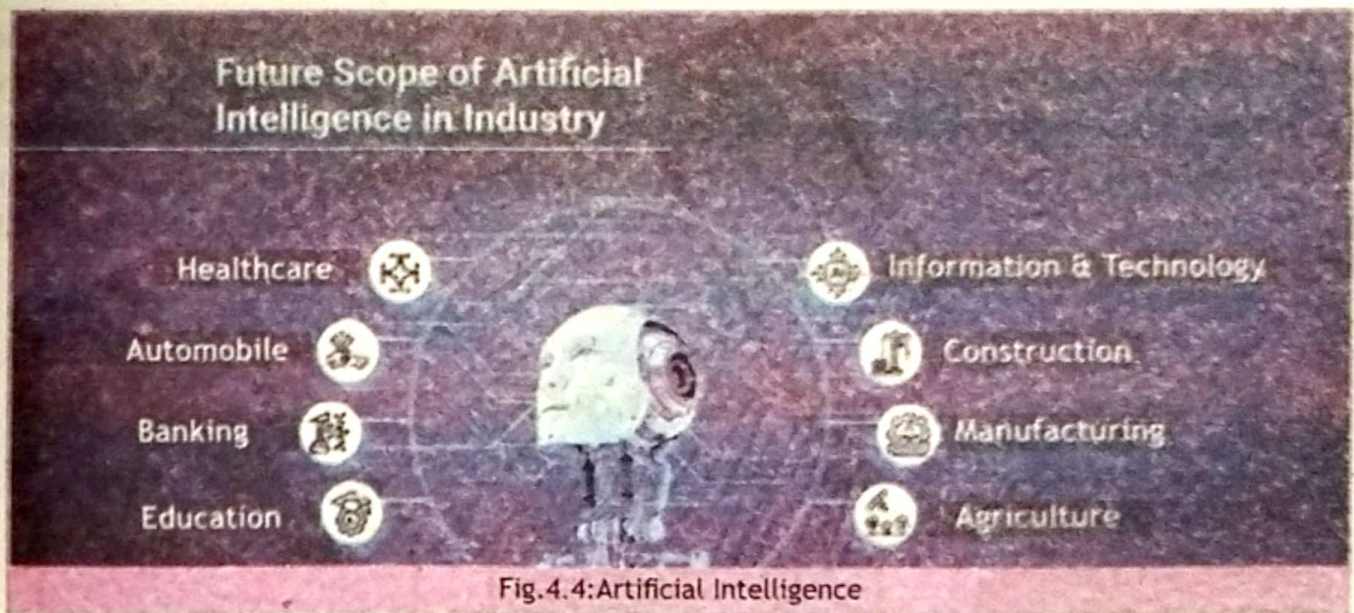

Decision making: Artificial intelligence is very useful in optimal decision making, based on a data driven approach.

Personalized recommendations: It helps to provide personalized feed to customers, based on their past usage of machines.

Automation industry: It has played a vital role in automating the tedious jobs like car manufacturing and image & video analysis. The most important utilization of artificial intelligence is integration of internet in the devices of daily use. The entire industry of IoT and smart devices is based on automation.

Natural Language Processing (NLP): AI enabled the machines to understand and respond to the natural human languages. ChatGPT and chatbots are examples of it. Now you can switch ON your conditioner with voice command rather than picking up the remote controller.

Robotics: Whether you watch some latest robot, talking and cooking like a human being or you use a small robot to clean your house, all this technology is due to significant advancement of artificial intelligence.

Healthcare: Like data science, artificial intelligence has played equally well in the field of healthcare. The examples are personalized treatment recommendations based on medical imaging.

Computer vision: It is a specialized branch of AI that teaches computers to draw meaningful results from digital images, videos and other visuals.

Smart cities: Artificial Intelligence enables to develop efficient infrastructure and services, which can be used to manage energy consumption, traffic management and other necessary tasks for smart cities.

AI Agents: Artificial Intelligence provides bases to develop modern AI agents like Siri, Alexa, Google assistant, ChatGPT and Cortana.

4.1.3 Machine Learning and its scope

Machine learning is used in many fields of life, like healthcare, automation industry, to develop recommender systems, finance and banking, pattern recognition, NLP, computer vision, research and innovation. An example of machine learning is Automated fraud detection. It helps to identify fraudulent activity by finding anomalies such as sudden large transaction or unusual network traffic. In short, the entire scope of Data Science and Artificial Intelligence is based on the algorithms developed in the field of Machine learning.

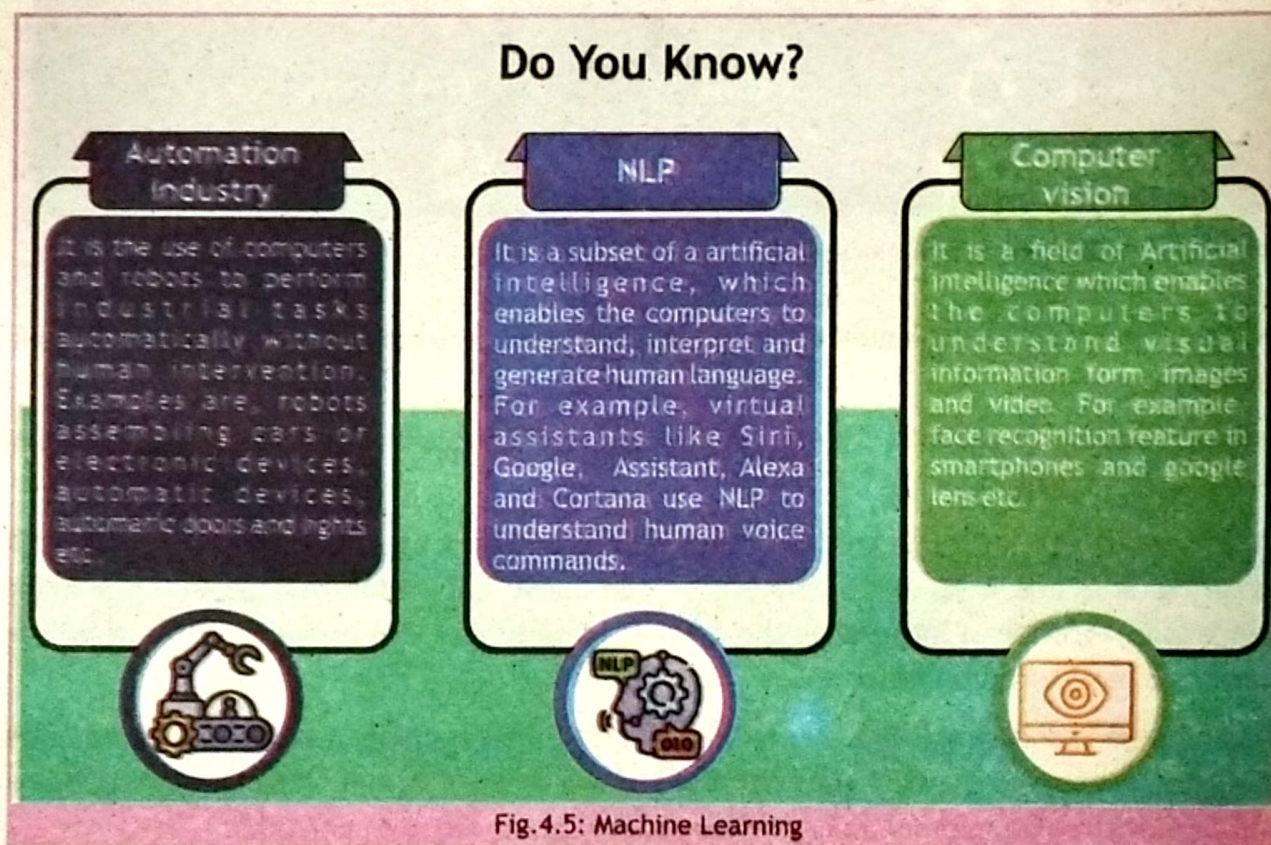

4.1.4 Data Science, Artificial Intelligence and Machine Learning Skills

Artificial Intelligence and Machine Learning skills refer to develop systems that can learn and perform decision making. Data Science skill refers to extract insights from data and make informed decisions. There are many skills to achieve excellence in artificial intelligence. These skills include programming language, machine learning, and acquiring domain specific

knowledge. In programming languages, Python and R are the most used languages in AI. In machine learning algorithms, the knowledge of TensorFlow framework, deep learning, neural networks and NLP are very important.

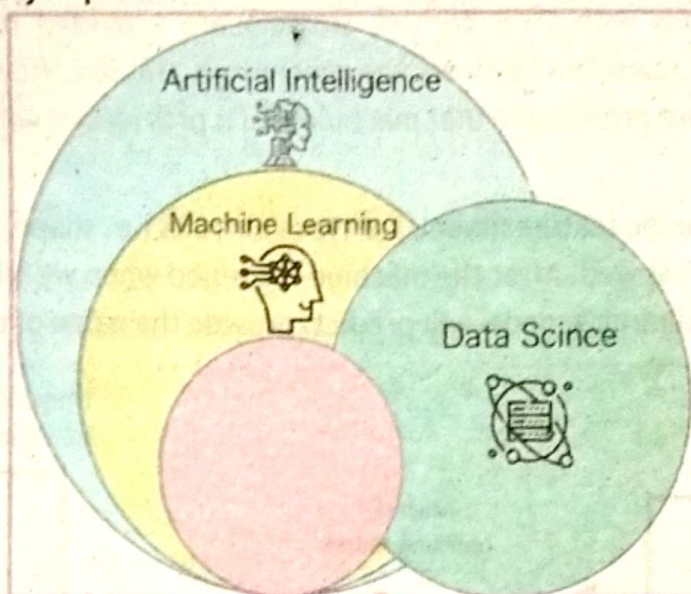

Fig.4.6: Data Science, Artificial Intelligence and Machine Learning

4.1.5 Machine Learning Models

Primarily, there are three models of machine learning.

- Supervised Machine Learning Model
- Unsupervised Machine Learning Model
- Reinforcement Machine Learning Model

Do You Know?



TensorFlow

TensorFlow framework is tool that helps computer form data like a robot. TensorFlow learns form data like a human being learn form experience.

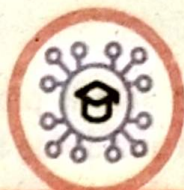

Deep Learning

Deep learning is a type of computer learning which uses layers of artificial neural network to learn from data. It is a learning method which is implemented by using some tool like TensorFlow.



Neural Network

Neural network is also known as Artificial Neural Network. It is system designed to work like human brain. It is made up of artificial neurons. These tiny neurons make decisions like human brain.

Fig.4.7: Machine Learning

4.1.6 Supervised Learning Model

In this learning model a set of labeled data is provided to the machine/computer. The labeled data means that questions with their correct answers are provided to the machine. After reading/learning a lot of questions/answers the machine is trained. Now, only new questions without correct answers are provided to that machine and it provides us with the possible correct answers.

For example, if we provide the features(labels) of types of fruits i.e. shape, color and texture and give their names(answers) as well. After the machine is trained when we will give the features of a new fruit the supervised learning model will predict/provide the name of that fruit.

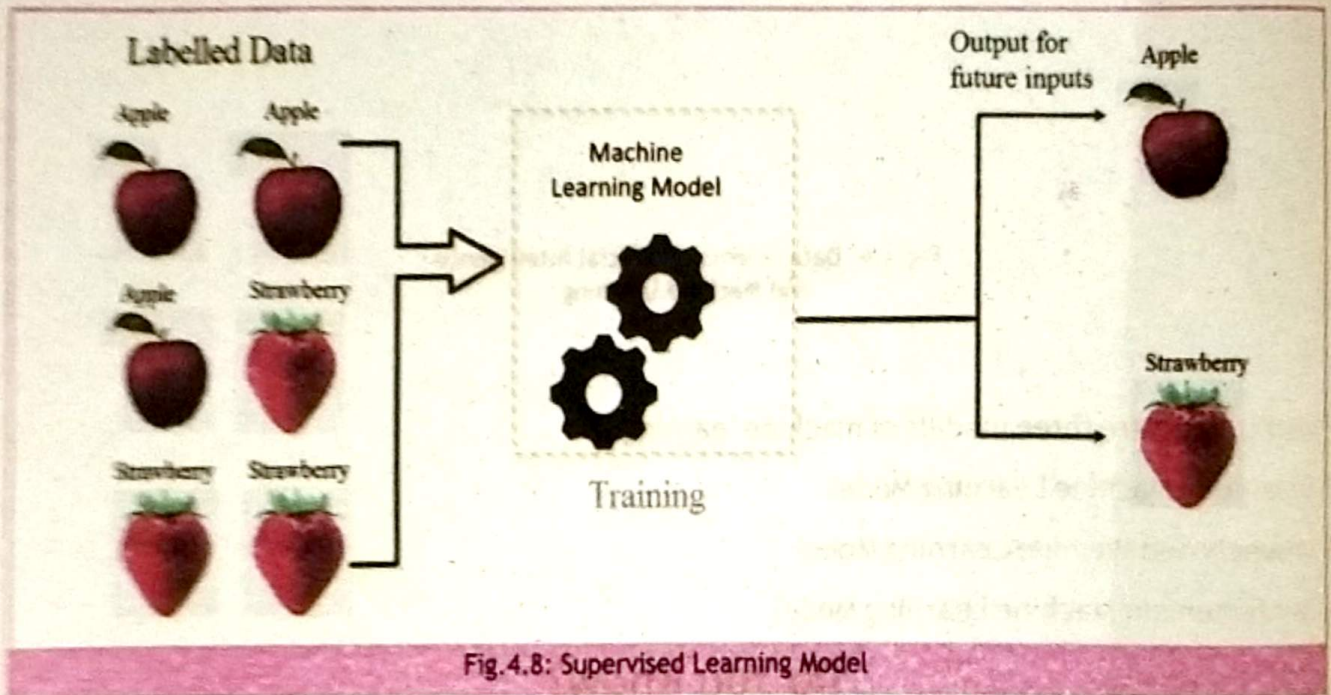

Fig.4.8: Supervised Learning Model

4.1.7 Unsupervised Learning Model

In unsupervised learning model, unlabeled data is provided to the machine/computer. The algorithm identifies the pattern in the data and divide it into groups based on similarities and differences. When the training is completed, the computer can identify new data and put it in the relevant category.

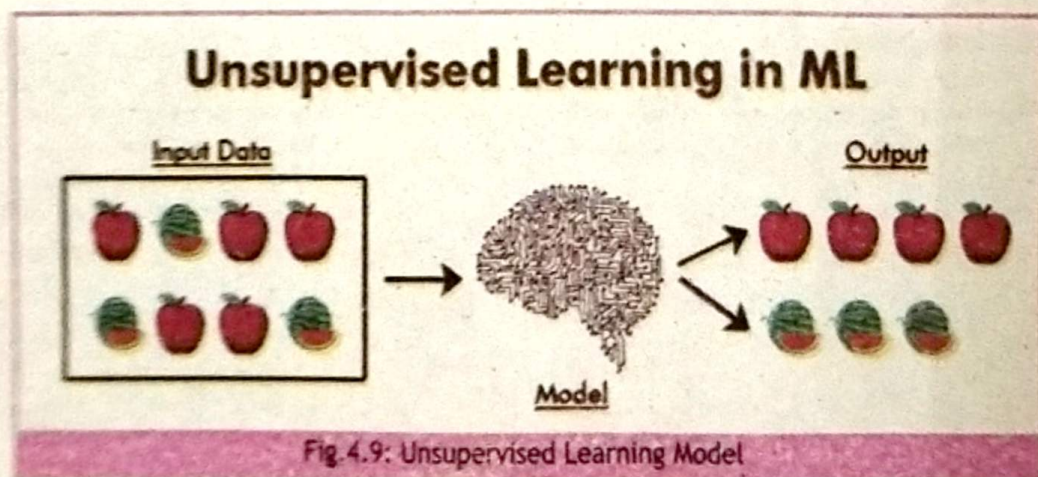

Fig.4.9: Unsupervised Learning Model

For example, if we provide various types of news to a computer then it will start dividing them into various groups, based on keywords. Suppose from a huge dataset the computer divides the news into various categories i.e. national politics, international politics, entertainment, medical, and technological news. When we give a new piece of information "Scientists successfully saved the cancer patients at last stage" to the computer, it will categorize it into medical news.

4.1.3 Reinforcement Learning Model

In reinforcement learning the machines are trained with the help of positive or negative feedback. To explain reinforcement learning we will use the following key terms:

1. Agent (machine/computer)
2. Environment (where agent takes actions)
3. Actions (moves made by agent)
4. Rewards (points for helpful actions)
5. Penalties (points deducted for unhelpful actions)

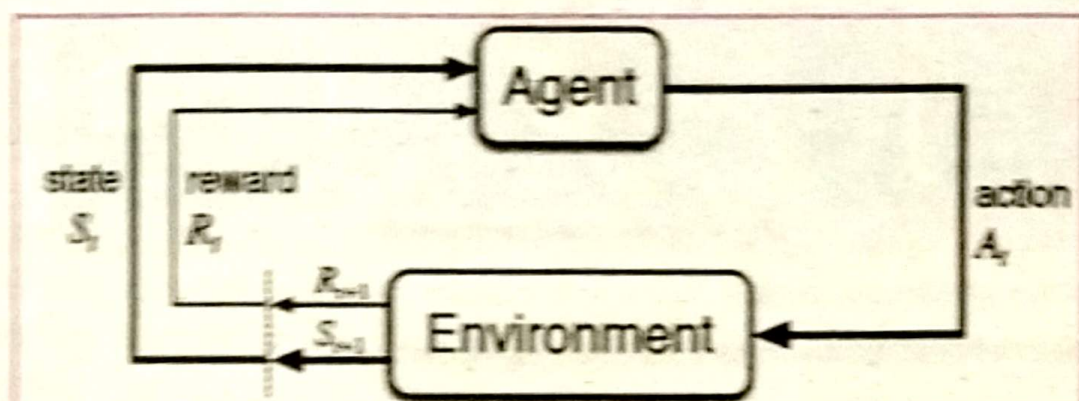

Fig. 4.10: Reinforcement Learning Model

The agent is provided with an environment where it must take certain actions, if the action is helpful towards the desired solution the agent will be rewarded with some points through feedback. If the actions are not helpful towards the desired solution the agent will be penalized (punished) by deducting the points. The agent improves its actions based on the feedback. This model is used to get optimal results.

For example, if you are learning to play chess and whenever you start your game by moving knights (name of a piece in chess game) you win, you will always try to start your game by moving knights. On the other hand, whenever you start your game by moving Queen piece, you lose the game. Therefore, you will always avoid moving Queen piece in the beginning of game in future. In this way, by winning and losing the game by moving certain pieces you have learned winning moves. In reinforcement learning this process is continuous until the model is trained and provides accurate results.

Fig. 4.10 shows reinforcement learning pictorially. The Agent (Chess Player) takes an action (moving Knight piece) at a certain time (in the beginning of the game). The Environment (Chess Board) is in certain state which changes after the Action A_t . Suppose the Agent moves Knight and

captures the Rook of the opponent player. The state of board changes to new state $S(t+1)$ The capturing opponent's rook is a rewarding move. In this way the Agent(Player) learns from his/her winning or losing moves and improves his/her performance by reinforcement learning.

4.1.9 Choose and appropriate machine learning model

As we learnt different models, how will we decide which machine learning model to use for a certain problem. First, we will define our problem, what output or solution we want? Do we want to identify some items, classify the given items, or forecast some future value. The next step is to analyze the given data.

If the given data has labels or questions/answers information, then we can use supervised learning model. If we don't have apparent labels and data have various groups which may have some similarities and some differences. We can apply unsupervised learning model. If in the given data, you identify some agent must achieve some goal then you will apply reinforcement learning model.

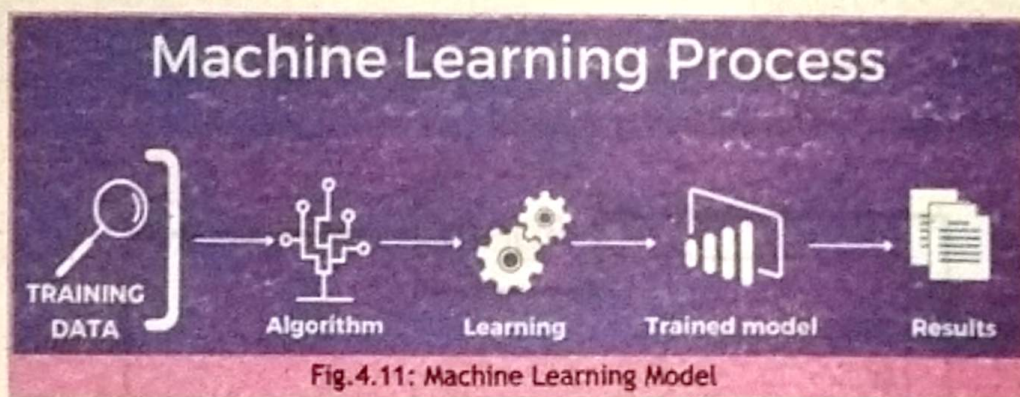

Machine Learning Process Steps:

Following is the brief description of Machine Learning Model:

Step 1: The preprocessed, cleaned data is split into Training data and Testing data. Sometimes we divide it into three parts and keep a small amount of data to validate the final results.

Step 2: A suitable algorithm is selected to train the machine. There are several algorithms like neural network, decision tree etc.

Step 3: The model is trained on the training set, it learns the pattern from data and develop a decision making ability.

Step 4: After the model is trained, test data and validation data is provided to the model and results are compared with actual values. The performance of the model can be improved by changing or improving the algorithm or by adjusting other necessary parameters which are beyond the scope of this book yet.

4.1.10 Artificial Intelligence, Machine Learning and Data Science(Similarities and Differences)

Artificial Intelligence is based on creating intelligent systems. Machine learning is a subset of AI that focuses on algorithms and statistical modeling to learn from data. Data science is used to get meaningful insight from the data to make informed decisions. There are many similarities and

differences among these three concepts. Some of these are as follows:

Similarities:

Data Driven Approach: All the three fields rely on data to provide optimal results. They use data to make predictions, recognize patterns and make decisions.

Use of Algorithm and Models: All the three fields work through various algorithms. For example, artificial intelligence relies on search algorithms. Machine learning relies on supervised/unsupervised/reinforcement learning algorithms. Data science relies on statistical and visualization algorithms.

Goal of Automation: The net goal of all the three fields is to automate various activities which were previously performed manually.

Differences:

Tools and techniques: They use various techniques, e.g. artificial intelligence uses neural networks, expert systems, and natural language processing. Machine learning uses supervised learning, unsupervised learning, reinforcement learning and deep learning techniques. Data science uses statistical analysis, data mining and data visualization techniques.

Application: The application of artificial intelligence is in speech and image recognition, autonomous vehicles, chatbots and virtual assistants. Application of machine learning is in recommendation system, fraud detection, predictive analysis, spam filtering, and personalized marketing. Applications of data science includes business intelligence, market analysis, healthcare analytics, risk management and scientific research.

Output: The output of artificial intelligence systems is that mimic human behavior. The output of machine learning is prediction and classification. The output of data science is insight, reports and visualization.

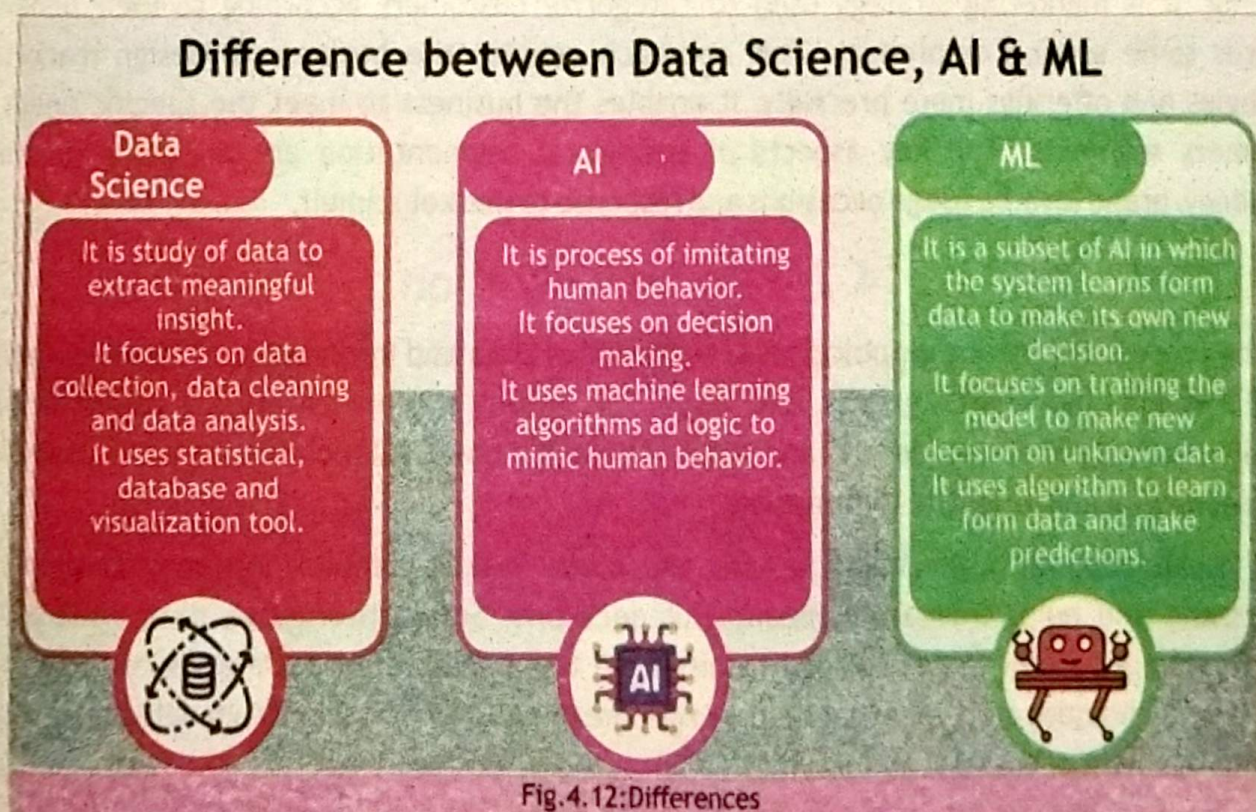

Fig.4.12:Differences

4.1.11 Churn Prediction and Behavioral Segmentations

Churn Prediction is the technique to find out the possibility of a customer, to stop taking the services or products of a certain company. It is used in the fields of business and marketing. For example, a telecommunication company receives frequent complaints about their service from certain customers, then they can predict that these customers might stop using their service. These unhappy customers can switch to some other telecommunication company. Churn prediction is needed to run the business successfully. It is often observed that getting new customers is less beneficial than keeping the existing customers loyal to your business.

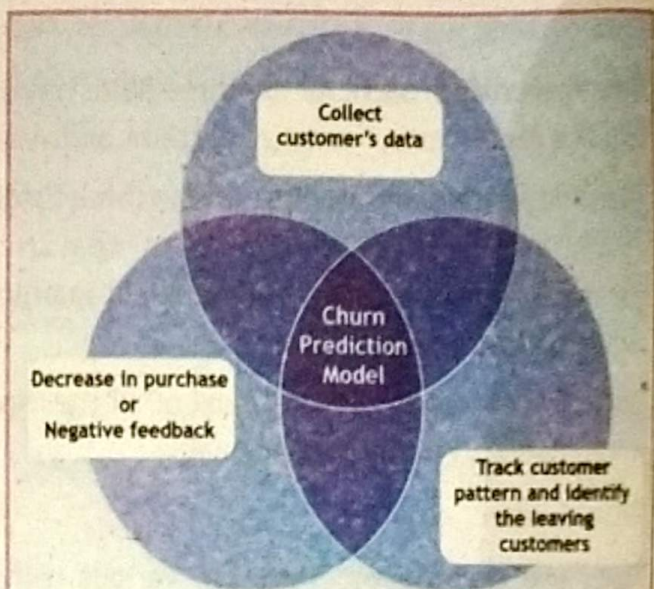

Fig.4.13: Churn Prediction and Behavioral Segmentations

For example, a store is selling formal clothing. The store wants to predict which customers might stop buying in the future. The store will collect data about the customers, how often the customers buy cloth (purchase frequency), since how long are they buying (brand loyalty) any feedback they provide about their products etc. After applying various algorithms and visualizing the results the store might observe that some customers are not visiting the store as often as they were visiting a few months ago. Then the store might send some personalized offers to the customers which can reduce the possibility of losing the customers.

Behavioral segmentation is the process of dividing customers into groups based on their behavior. It is marketing strategy used to categorize customers according to their behavior towards some service or product. This approach enables the business to design marketing strategies and offerings more precisely. It enables the business to meet the specific needs of customers segments. The key aspects of behavioral segmentation are analyzing purchase frequency, brand loyalty, usage occasions and response to market stimuli.

4.2 Data Visualization

It is the process of creating graphical representation of data and information. It involves various visual elements like charts, graphs, and maps. This graphical representation is useful to make decisions in the field of science, arts and in daily life. It is a powerful tool that transforms raw data into meaningful and insightful information.

Data visualization through charts, graphs and plots, makes complex information simple to understand and helps in making meaningful decisions. Some interactive data visualization techniques are helpful to get optimal results from the available data. Data visualization have variety of techniques and types that helps to get meaningful information from data and use it for the improvement of business and services.

4.2.1 Methods of Data Visualization

Methods and types of data visualization are interrelated terms. However, methods of data visualization are the techniques to prepare data for visualization. These methods are explained briefly as follows:

Bar Chart: This method of data visualization is used to show comparison among discrete values. For example, we can use Bar Chart to visualize marks of students in various subjects or sales data of various products in a company.

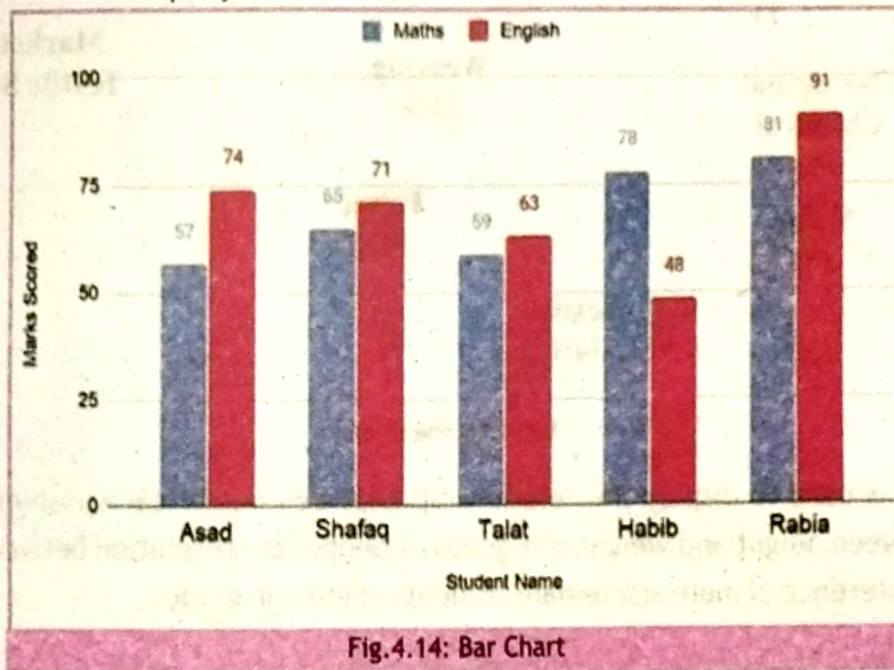

Fig.4.14: Bar Chart

Line Chart: It is used to display trends of data over short or long period of time. For example, gold prices over the last five or ten years can be displayed by using a Line Chart. Similarly, stock prices, or change in temperature over a year can be presented by using a Line Chart.

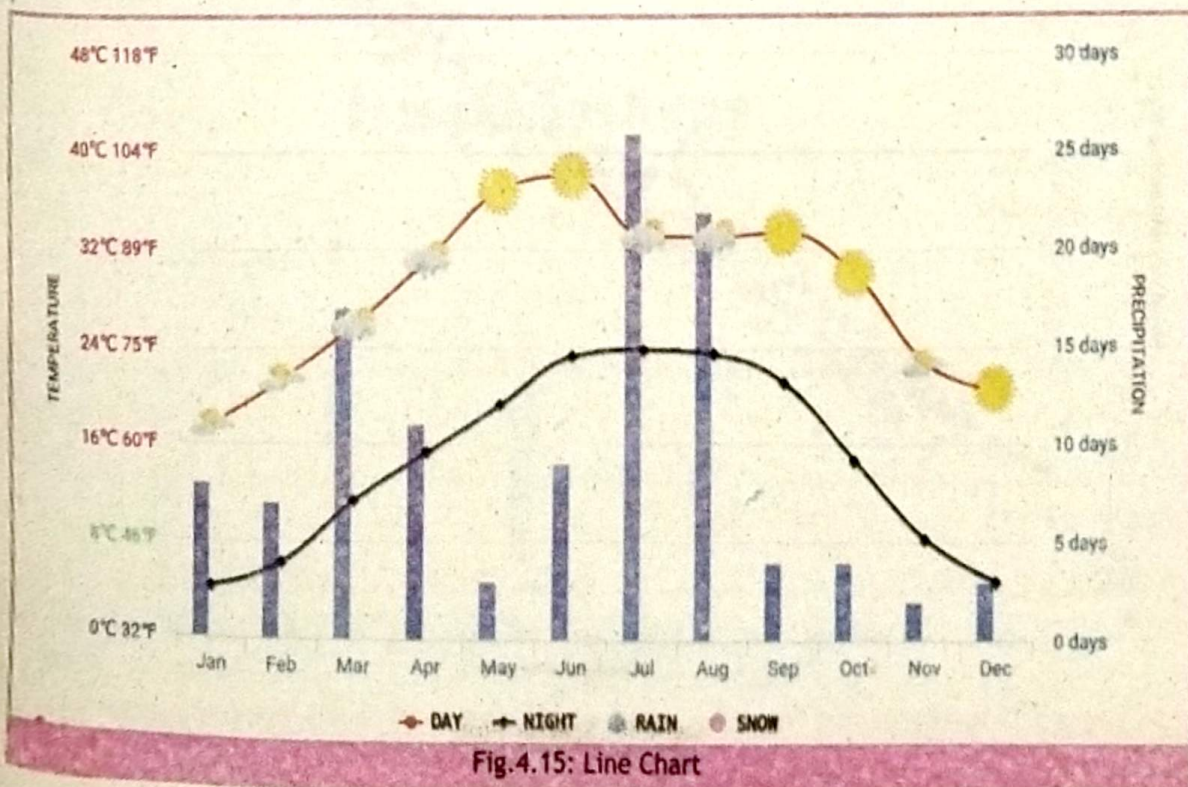
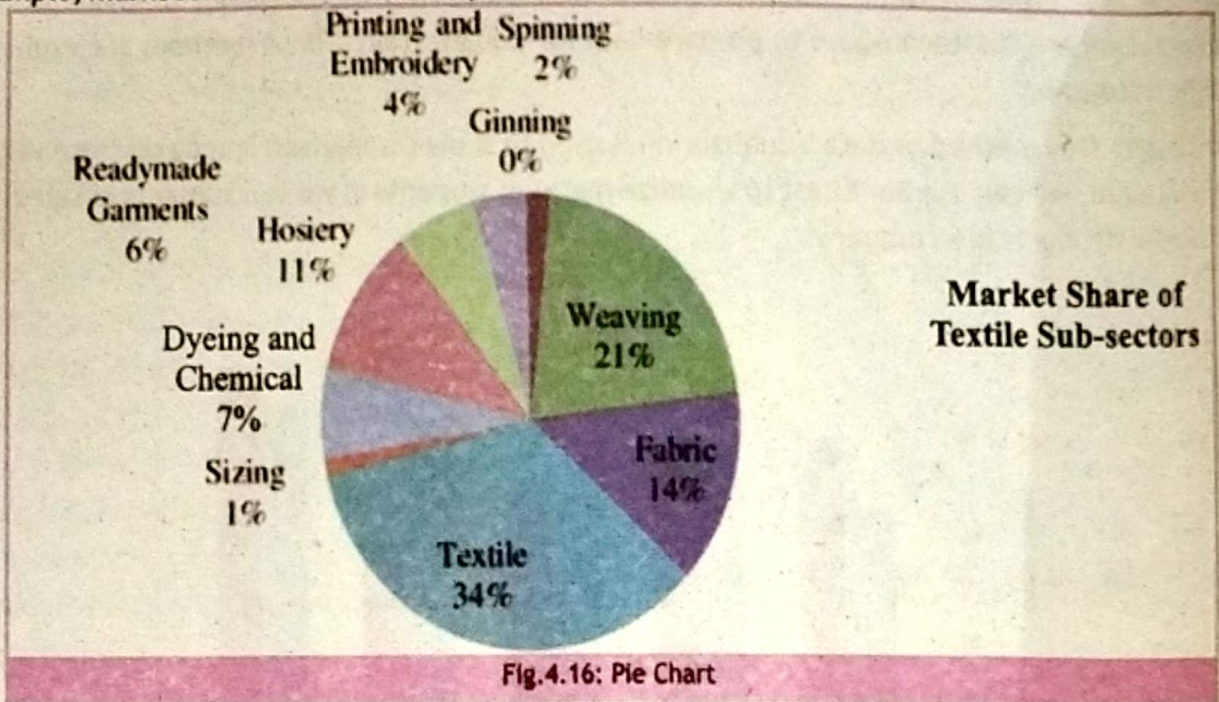

Fig.4.15: Line Chart

Pie Chart: It is used to represent proportions of various categories of data in a whole. For example, market shares of various companies.



Scatter Plot: It is used to display the relationship between numerical variables. For example, correlation between height and weight of a group of people or correlation between head volume and head circumference of male and female students of certain grades.

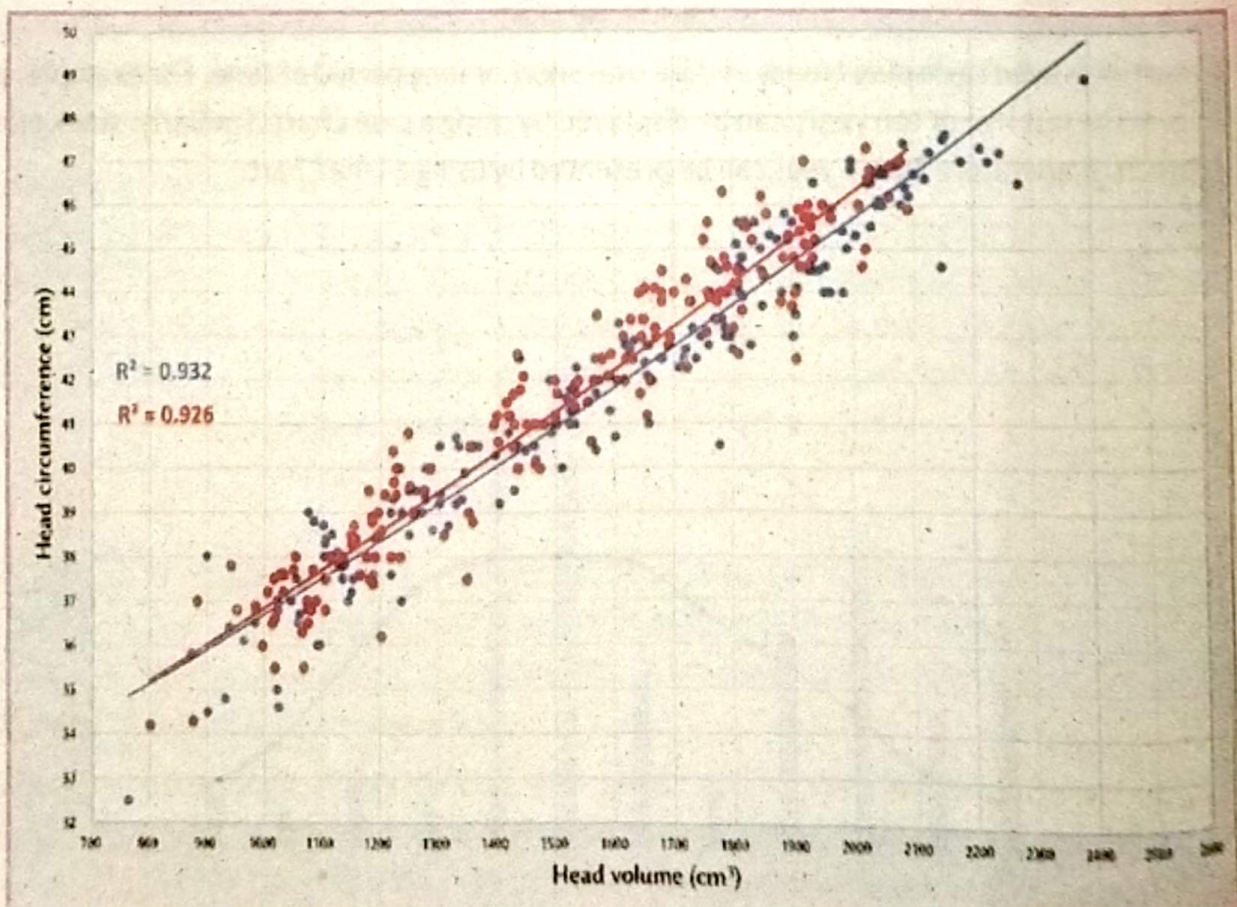

Fig.4.17: Scatter Plot

Histogram: It is used to show the distribution of a single numerical value. For example, distribution of score in a class.

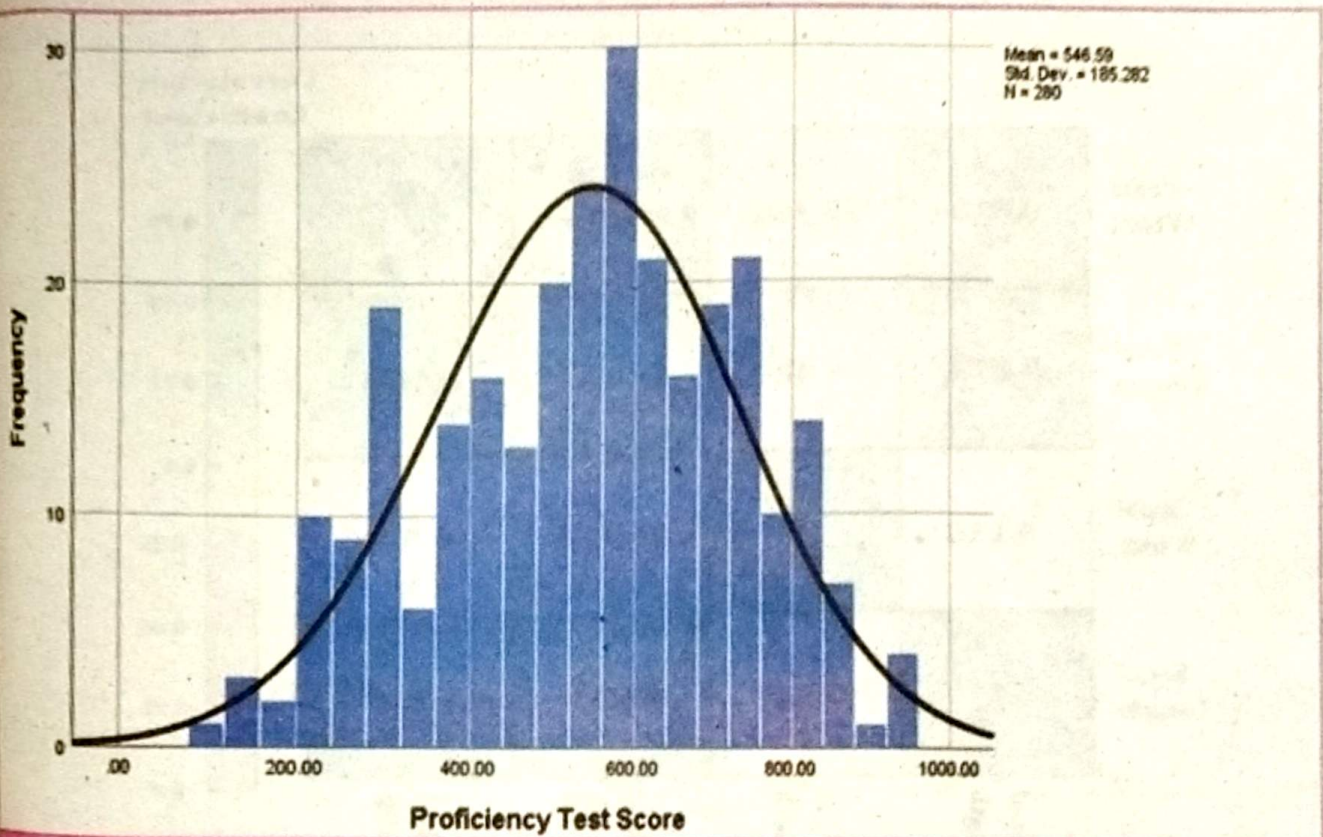

Fig.4.18: Histogram

Box Plot (Box-and-Whisker Plot): It is used to summarize the distribution of data with the help of minimum, first quartile, median, third quartile and maximum data. For example, analysis of salaries of various employees in a company.

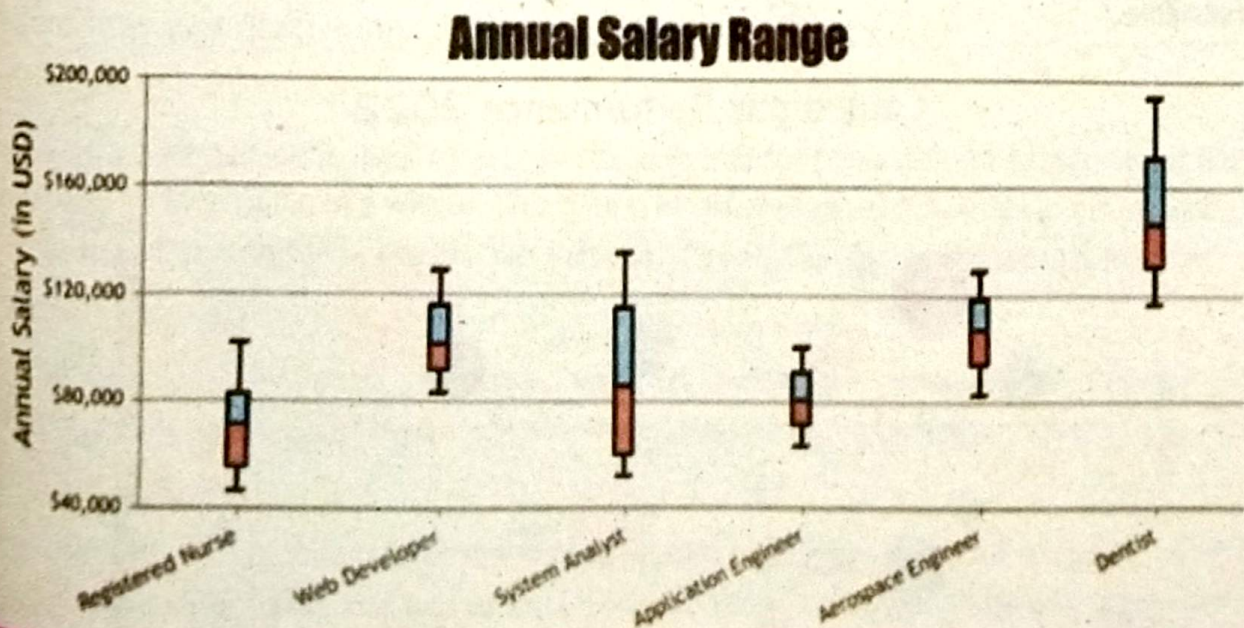

Fig.4.19: Box Plot (Box-and-Whisker Plot)

Heatmap: It is used to represent data in matrix form. Data values are shown by using color intensity. For example, images received from the space to analyze weather forecast. Another example is of climate change, or measurement of different parts of flowers.

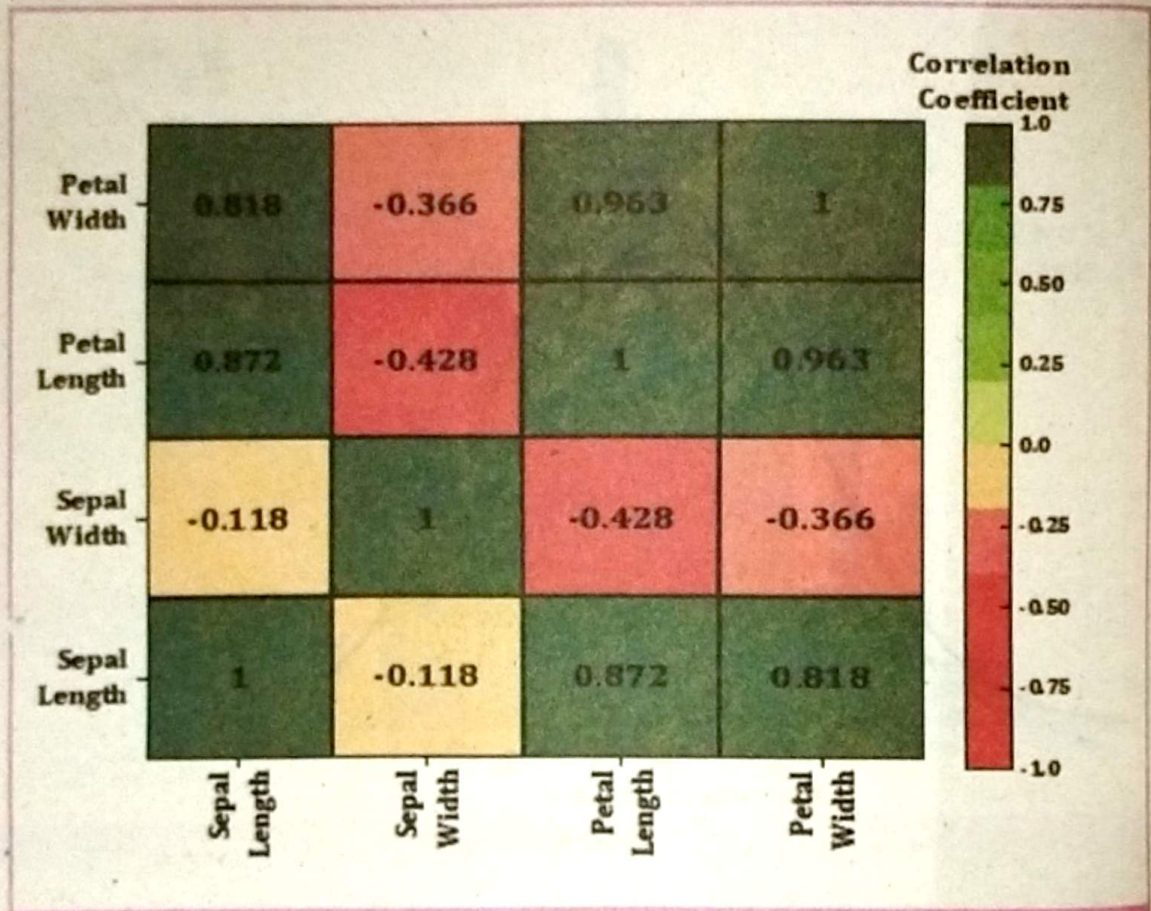

Fig.4.20: Heatmap

Bubble Chart: It is similar to scatter plot, but it has a third variable which is represented by the size of bubble. For example, points in a 2D space where area of each point is proportional to the third variable.

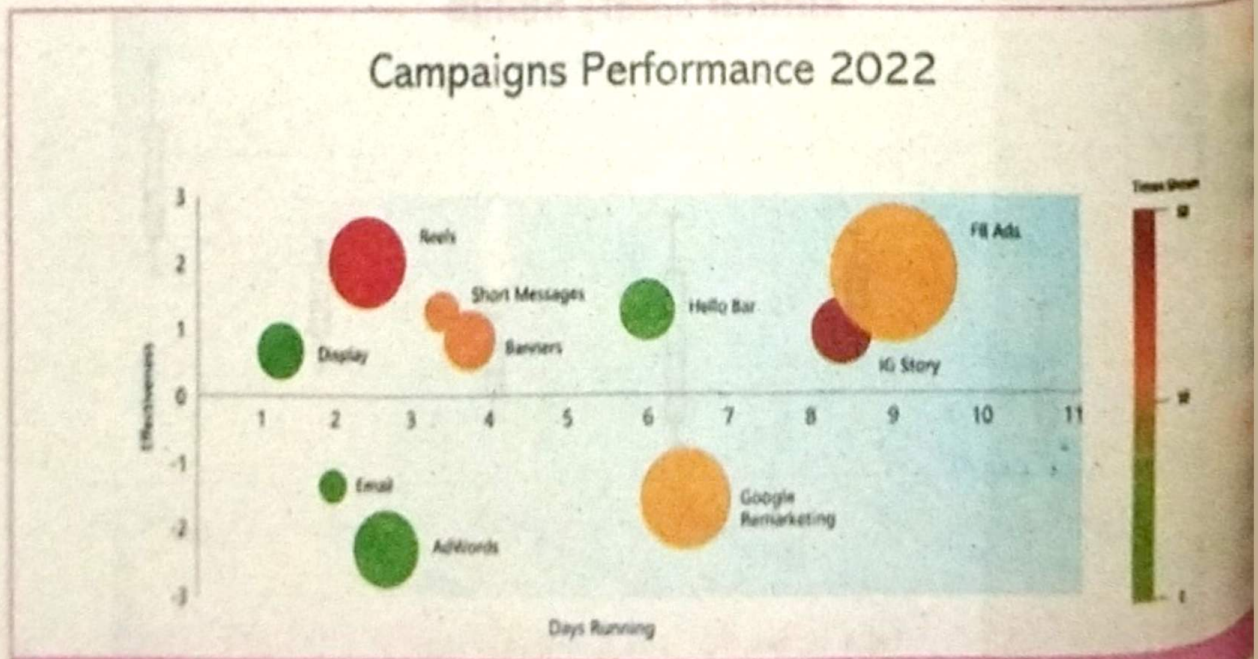

Fig.4.21: Bubble Chart

4.2.2 Types of Data Visualization

There are different ways to represent data graphically to make it easier to understand. Some common types of data visualization are as follows:

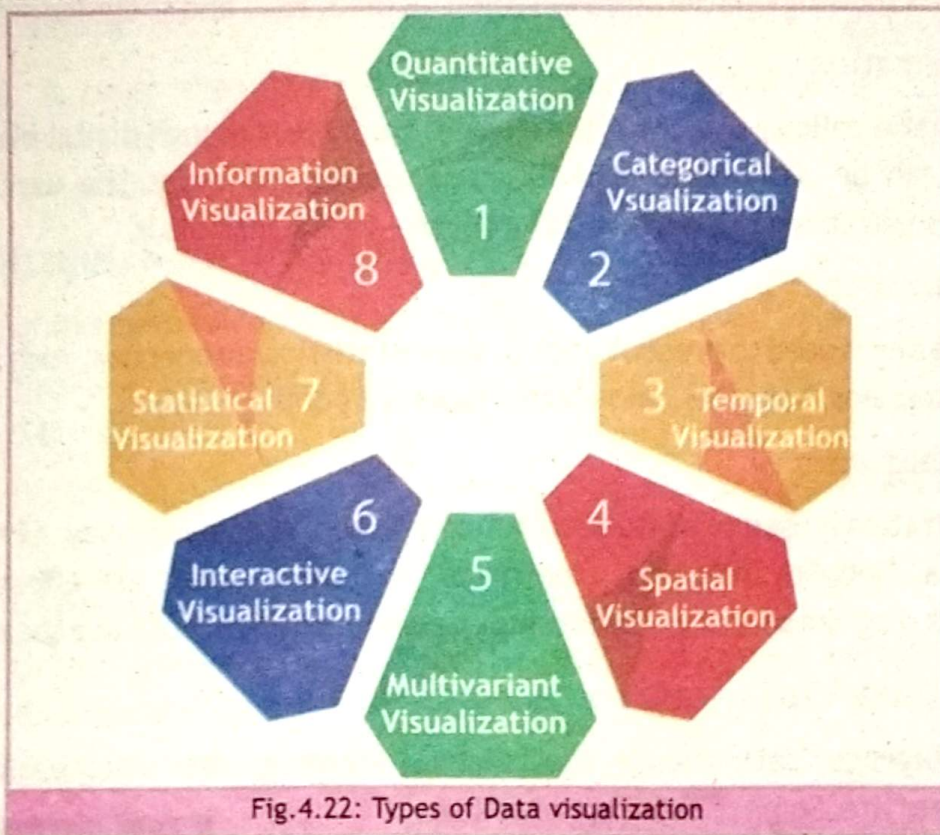

Fig.4.22: Types of Data visualization

Quantitative Visualization

Quantitative visualization is used to represent numerical data. It focuses on quantities or numbers to show measurable data. It is used to display data that can be measured or counted. For example, a bar chart showing sales figures of a company over several months effectively communicates quantitative information.

Categorical Visualization

Categorical visualization is used to represent data that falls into distinct categories. It helps to show proportions or parts of a whole. This type is ideal for displaying nominal or ordinal data. For example, a pie chart showing the market share of different companies in a specific industry.

Temporal Visualization

Temporal visualization is used to display data that changes over time. It is used for time-series data. Line graphs are usually used to represent temporal data. For example, a line graph.

Spatial Visualization

Spatial visualization is used to represent data related to physical locations or spaces, visualizing geographic or spatial data. For example, a heatmap showing population density across different regions.

Multivariate Visualization

Multivariate visualization is used to represent data involving more than two variables or dimensions. Scatter plots and heatmaps are effective tools to represent such data. For example, a scatter plot matrix showing relationships between income, age, and spending habits.

Interactive Visualization

Interactive visualization allows users to interact with the data, through digital platforms. These digital platforms can be dashboards and filters. A dashboard helps the user to filter and manipulate data visualizations and explore different trends and insights.

Statistical Visualization

Statistical visualization is used to present data to show statistical properties, such as distribution or correlation. Histograms, box plots, and scatter plots are popular choices.

Information Visualization

Information visualization is used to present complex data sets in an easier way, often for abstract or conceptual data. Network diagrams, tree maps, and word clouds are effective tools. For example, a network diagram showing relationships between entities, such as a social network.

4.2.3 Uses of Data Visualization

Like Artificial Intelligence, data science and machine learning, data visualization is useful in almost all the fields of life. Some of them are as follows:

Business Intelligence: Data visualization helps to make data driven, well informed decisions. It is used to find market trends and helps to track and improve performance.



Healthcare: It helps to visualize the impact of various diseases affecting the patient. It is helpful to track disease and visualize the spread of disease.

Education: Data visualization is very helpful to teach data literacy skills, concept building, creative thinking, and critical thinking.



Science and Research: It is useful to visualize complex findings, very huge and complex data such as complex scientific data received from satellite in the form of photographs.

Sports and gaming: It is useful to visualize performance of players whether they are playing football in a ground or chess players playing in online tournaments. It is also helpful in sports broadcasting, and other predictions.





Finance: It is helpful to analyze market trends, to track portfolio performance and to identify investment opportunities.

Entertainment: It helps the entertainment industry, to visualize movie performance data to predict future trends. It helps in content optimization by visualizing audiences insights and trends.



1.2.4 Advantages/Benefits of Data Visualization

Data visualization has many advantages and benefits, some of them are as follows:

- ▶ It helps non-technical stakeholders to understand complex data and make decisions regarding their business and services.
- ▶ It helps the decision-makers understand the existing data and make well informed strategic decisions.
- ▶ It improves the performance of related business or services.
- ▶ It helps in better communication, understanding, and getting better insight from well-organized real-time data.

Data visualization saves time and identify trends quickly.

It saves time and enable us to make quick and accurate decisions as compared to manual analysis.

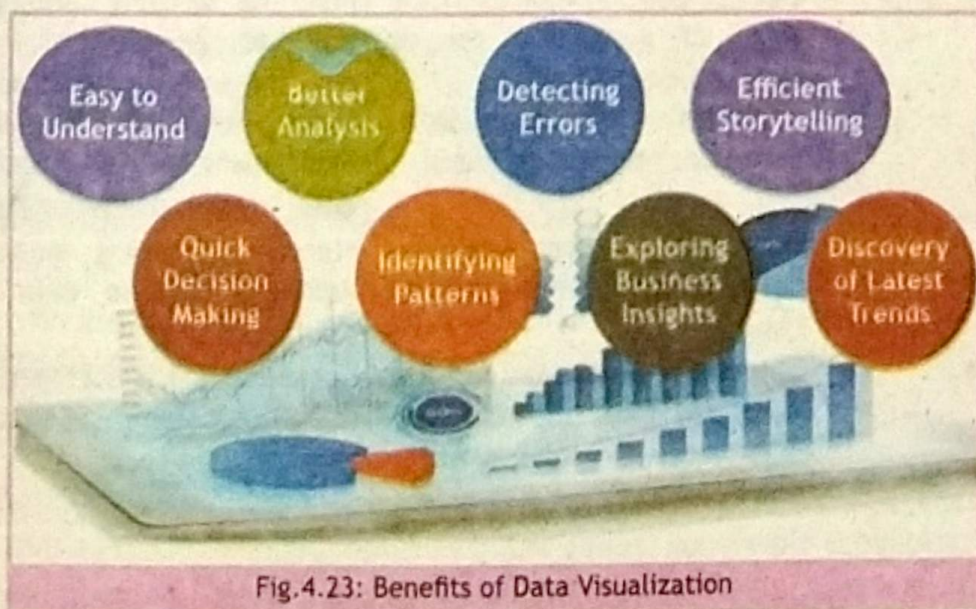

Fig.4.23: Benefits of Data Visualization

2.3 Database and Machine Learning

Database is collection of related data stored in the form of tables. Various computer software is used to create databases to store data in organized form so that it can be managed, retrieved and accessed efficiently. Traditionally databases have a key role in the development of modern technology of computer science. Oracle, Ms-Access and MySQL are some well-known database

management software used to create and manage databases.

Apparently, database and machine learning seem to be very distinct disciplines of computer science domain. However, they are interrelated closely. To understand relationship between these two disciplines, the simplified information is given as follows:

Characteristics	Database	Machine Learning
Data storage	In database data is stored in structured format such as table.	Algorithms of machine learning require the same structured data to train their models. Datasets are organized in rows and columns.
Data preprocessing	Database stores data after normalization, therefore data is clean without any duplication, data redundancy and other errors.	Machine learning also require clean data. If the data is not clean the performance/result of the algorithm is affected.
Data retrieval	As data is stored in the tables in an organized manner, the retrieval of data through SQL queries is very easy, fast and reliable.	Data is organized in the form of Dataset; therefore, it can be retrieved by using simple and easy algorithm of machine learning.
Data Integration	Data in a database is kept integrated. It is stored after removing duplicated values and other possible errors. Therefore, integrity of data in the database is assured.	For comprehensive model training integrated data is required. In this way Data provided by the database is equally useful for machine learning to train its algorithms.
Scalability	DBMS can handle various sizes of databases ranges from student database of 50 students to the database of entire country or even more.	Machine learning requires scalable data storage solutions. In this way it can implement big data applications. Number of records in a dataset varies from hundreds to thousands and even in millions in a single dataset.
Realtime Data Processing	Database provides Realtime data storage and retrieval support.	Machine learning model requires Realtime data to train model for online data.
Analytical Tools	Database provides various tools for data analysis, e.g. SQL server and other software etc.	Database analytical tools are helpful for machine learning to provide fast and accurate solutions.

4.3 Stages of the Data Science Life Cycle

Data science life cycle is an iterative process. It has various stages, each has certain steps to be taken to move forward. It requires a structured approach to solve data driven problems. The stages of data science life cycles are as follows:

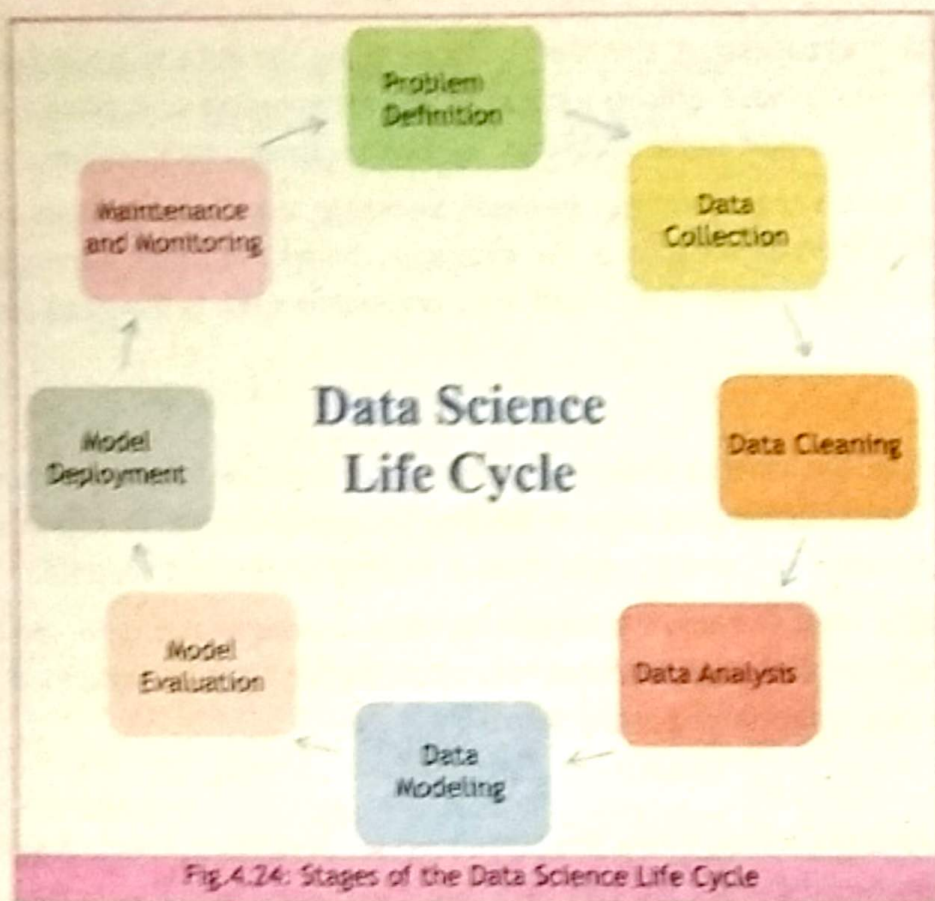

Problem Definition:

In this stage the business problem or research question is defined with clear objectives and outcomes. The scope and limitations of the problem are determined. Preliminary research and literature reviews help the stakeholders to understand their needs and expectations.

Key performance indicators (KPI) are defined to measure the success of proposed solutions. KPIs are measurable targets that help us track progress and success of a process.

For example, increasing sales by 15% in two months can be set as a KPI of some business problem. Another example of KPI is improve the speed of website loading by 20% in 30 days. By setting KPIs, we can focus on finding the right solutions and track our progress. The outcome of this stage is a hypothesis or well-defined problem.

Data Collection:

In this stage, data is gathered by using various reliable and useful sources. The method of data collection depends on the kind and complexity of problems. For simple problems, we can observe and write down what we see, while more complex problems we might need surveys, experiments, or even using online services through APIs (Application Programming Interface). APIs are small programs that act like messengers between two or more software.

They are like waiters in a restaurant who receive an order from us and bring back the food as a response to our order. The data collected should be relevant and accurate, as the quality of the data directly affects the results at later stages.

Data Cleaning:

It is also called data preprocessing, this step is about fixing the data to make sure it's ready for analysis. In this step we remove errors, such as wrong information or duplicate values. If some values are missing, which might cause problems, we fill in with estimated values.

During this process, data is organized into an easily workable format. Sometimes, new features or attributes are created from existing data. For example, if we have dates, we might create a new column for the day of the week. Clean and well-organized data is essential for making good predictions later on.

Data Analysis:

After cleaning the data, we have to analyze it. Statistics or machine learning techniques are used for data analysis. These techniques help in finding patterns, trends, or important details. By looking at the data closely, we can test early ideas or assumptions about the data.

For example, we might want to know if a certain factor is causing an outcome, like is the weather affecting sales of certain products? At this stage, visualization tools like graphs or charts can be used to understand what's happening in the data.

Data Modeling:

In this stage, the data is organized into a structured model. It helps to create diagrams that show the relationships between different entities (like customers and the products they purchase) and their attributes (like names, prices, or dates).

We also focus on how to store and retrieve this data efficiently by setting up databases or other systems. Once the model is ready, it is tested using historical / previous data to see if it performs well. The goal is to create a structure that can be easily used for predictions or other analysis.

Model Evaluation:

At this stage we evaluate the performance of our machine learning model. This is done by measuring how accurate and reliable the model is, and whether it meets the performance goals we set earlier.

For example, we can test how often the model makes the right predictions or how fast it delivers results. If the model doesn't perform as expected, we might need to go back to the data modeling stage to make improvements. This stage also includes making sure that the data and the model are secure and respect privacy rules, especially if sensitive information is involved.

Model Deployment:

Once the model is working well, it is time to deploy it for use. This stage is called deployment, and it means the model is set up in the system or infrastructure where it will be used. It means to integrate the model on a website, application, or database.

Sometimes, deployment is done in small steps (partial deployment) to test if everything works fine before launching it completely. Other times, the model is deployed all at once. After deployment, the model starts working with real data, providing insights or making predictions.

Maintenance and Monitoring:

After the model is deployed, it is important to keep an eye on how it performs. This is a continuous process where the model's accuracy, speed, and reliability are monitored over time. If any issues are detected, like the model becoming less accurate or slow, adjustments can be made.

Feedback from users can also help improve the model. This ongoing maintenance ensures that the model remains useful and effective as conditions change, like if new data becomes available or the problem evolves.

4.3.1 Case Study: Understanding a real-world business problem and its formulation to data science problem

We will learn to apply the data science life cycle in real-world business problem. Suppose we have a task to optimize the inventory of a smart phones.

Problem definition: Suppose you own a super store and you want to ensure that you want to have good enough stock of popular smart phones. The objective is that you don't run out of stock to meet the demand of your customers. Keeping in mind that you also don't want to make unnecessary purchases that would be difficult to sell.

Data Collection: The first step is to gather data related to the smartphone stock and sales. The data includes:

- Current stock levels for each smartphone model (how many phones of each type are in stock).
- Sales data showing which models are selling fast and which are slow-moving.
- Supplier information about new models and upcoming promotions or price changes.

This data can be collected from several sources, like the store's sales system, purchase invoices, supplier's record, and even from customers' feedback on popular models. Gathering this data helps the superstore understand the current state of their inventory and the demand trends.



Data Cleaning: After collecting the data, the next step is to clean it to ensure accuracy. This involves:

Removing duplicates: such as cases where the same model is listed multiple times with different spellings or slight variations.

Fixing errors: in the stock levels and sales data, like incorrect quantities.

Handling missing values: such as missing prices or sales figures, by cross-referencing supplier information or older data.

By cleaning the data, the you ensure that the inventory and sales data is reliable and ready for analysis. For example, if there are missing prices for certain models, they can be updated with information from suppliers.



DO YOU KNOW?

Investigator: An investigator is a person who conducts the statistical enquiry.

Enumerators: To collect information for analysis, an investigator needs the help of some people. These people are known as enumerators.

Data Analysis: Now that the data is clean, the next step is to analyze it. The goal of this analysis is to understand which smartphone models are in high demand and which are not selling well. Key questions to answer include:

- Which models sell the fastest?
- Which models have stayed in stock for too long?
- Are there seasonal patterns in sales?



After answering these questions, you can identify the smartphones that need to be reordered more frequently and the ones that are less popular. Visualization tools like graphs or charts can help show sales trends over time, making it easier to see which models are consistently popular.

Data Modeling: At this stage, you will build a model to keep track of inventory levels and predict future demand. The model includes:

- Attributes for each smartphone like model, price, stock level, and sales history.
- Relationships between stock levels and sales rates. For example, when a phone sells quickly, the stock level drops, and the system signals the need for a reorder.

The model can use historical sales data to predict future demand, it helps to avoid running out of popular phones. In this way you will prevent overstocking on less popular models. The model is tested using past data to ensure it works accurately before it is put into use.

Model Evaluation:

After completing the model you will evaluate it to see how well it predicts inventory needs. Key performance measures include:

- Accuracy: How well does the model predict when a phone will go out of stock?
- Efficiency: Does the system notify the staff, in time to reorder popular models before they run out?
- Cost-effectiveness: Is the system helping the store avoid over-purchasing models that don't sell well?

If the model doesn't perform as expected, adjustments can be made. For example, if the model predicts too many unnecessary purchases, the store might fine-tune it to be more careful in its predictions. Security of sales data is also evaluated to ensure it is handled responsibly.

Model Deployment: Once the model is ready, it is deployed in the store's inventory management system. This could involve setting up alerts when stock levels of popular smartphones get low. Integrating the model into the store's existing sales software. The deployment may be done in phases, starting with a few popular models, or it may be used across the entire inventory at once. After deployment, the model starts working in real-time, sales tracking and adjusting stock levels accordingly.

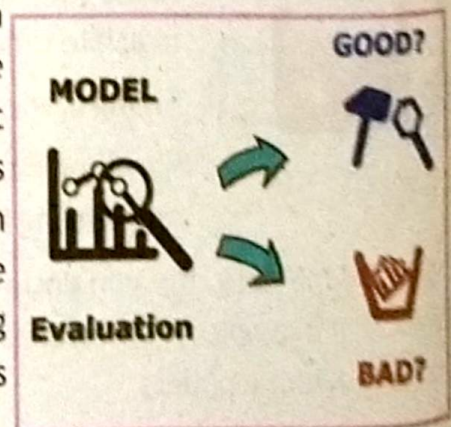

Model Evaluation: Monitor the performance of the model by comparing the actual sales records with the predicted sale data. Adjust the model as needed to improve the accuracy of this model.

Maintenance and Monitoring:

After the model is deployed, you will continue to monitor its performance. This ongoing stage includes:

- ▶ Checking if the machine learning model correctly alerts staff when stock is low for popular models.
- ▶ Ensuring the store is not over-ordering less popular or even popular phones.
- ▶ Collecting feedback from store staff to see if the system is easy to use and helping them manage the inventory better.

Regular updates are made to improve the model, such as incorporating new data on sales trends or adjusting reorder levels based on changes in customer preferences. The system is continuously refined to ensure that the superstore never runs out of stock for popular models while avoiding excess inventory.

By following the above data science life cycle, the superstore successfully developed a system to manage its smartphone inventory more efficiently. The system helps the store keep popular smartphones in stock while preventing over-purchasing of less popular models, ensuring customer demand is met without wasting resources.

Unit Summary

- **Data science:** It is a branch of knowledge, which joins together mathematics and statistics skills with the programming domain of computer science. It refers to an interdisciplinary field of mathematics, statistics, and computer science.
- **Turing Test:** It measures the ability of machine to exhibit intelligent behavior.
- **Artificial Intelligence:** is referred to the ability of a machine to exhibit human behavior like problem solving, understanding natural language and interacting with the environment intelligently. **Personalized recommendations:** It helps to provide personalized feed to customers, based on their past usage of machines.
- **Automation industry:** It has played a vital role in automating the tedious jobs like car manufacturing and image & video analysis. The most important utilization of artificial intelligence is integration of internet in the devices of daily use. The entire industry or IoT and smart devices is based on automation.
- **Natural Language Processing (NLP):** AI enabled the machines to understand and respond to the natural human languages. ChatGPT and chatbots are examples of it. Now you can switch ON your air conditioner with voice command rather than picking up the remote controller.
- **Robotics:** Whether you watch some latest robot, talking and cooking like a human being or you get a small robot to clean your house, all this technology is due to significant advancement of artificial intelligence.
- **Computer vision:** It is a specialized branch of AI that teaches computers to draw meaningful results from digital images, videos and other visuals.
- **Smart cities:** Artificial Intelligence enables to develop efficient infrastructure and services, which can be used to manage energy consumption, traffic management and other necessary tasks for smart cities.
- **AI Agents:** Artificial Intelligence provides bases to develop modern AI agents like Siri, Alexa, Google assistant, ChatGPT and Cortana to generate human language. For example, virtual assistants like Siri, Google Assistant, Alexa and Cortana use NLP to understand human voice commands.
- **Deep learning:** is a type of computer learning which uses layers of artificial neural network to learn from data. It is a learning method which is implemented by using some Neural network.
- **Neural Network:** It is system designed to work like human brain. It is made up of artificial neurons. These tiny neurons make decisions like human brain.
- **Supervised Learning Model:** In this learning model a set of labeled data is provided to the machine/computer. The labeled data means that questions with their correct

answers are provided to the machine. After reading/learning a lot of questions/answers the machine is trained. Now, only new questions without correct answers are provided to that machine and it provides us with the possible correct answers.

- **Unsupervised learning model:** In this model unlabeled data is provided to the machine/computer. The algorithm identifies the pattern in the data and divide it into groups based on similarities and differences. When the training is completed, the computer can identify new data and put it in the relevant category.
- **Reinforce learning model:** In this model the machines are trained with the help of positive or negative feedback. The agent is provided with an environment where it must take certain actions, if the action is helpful towards the desired solution the agent will be rewarded with some points through feedback. If the actions is not helpful towards the desired solution the agent will be penalized(punished) by deducting the points.
- **Churn Prediction** is the technique to find out the possibility of a customer, to stop taking the services or products of a certain company. It is used in the fields of business and marketing.
- **Behavioral segmentation:** is the process of dividing customers into groups based on their behavior. This approach enables the business to design marketing strategies and promotional offers more precisely. It enables the business to meet the specific needs of customers segments.
- **Data Visualization:** It is the process of creating graphical representation of data and information. It involves various visual elements like charts, graphs, and maps.
- **Methods of Data Visualization:** Methods of Data Visualization are Bar Chart, Line Chart, Pie Chart, Scatter Plot, Histogram, Box Plot, Heatmap, Bubble Chart etc.
- **Quantitative visualization** is used to represent numerical data. It focuses on quantities or numbers to show measurable data. It is used to display data that can be measured or counted.
- **Categorical visualization** is used to represents data that falls into distinct categories. It helps to proportions or parts of a whole. This type is ideal for displaying nominal or ordinal data.
- **Temporal visualization** is used to display data that changes over time. It is used for time-series data. Line graphs are usually used to represent temporal data
- **Spatial visualization:** is used to represent data related to physical locations or spaces, visualizing geographic or spatial data. For example, a heatmap showing population density across different regions. **Multivariate visualization:** is used to represents data involving more than two variables or dimensions. Scatter plots and heatmaps: are effective tools to represent such data. For example, a scatter plot matrix showing relationships between income, age, and spending habits.

- **Interactive Visualization** Interactive visualization allows users to interact with the data, through digital platforms. These digital platforms can be dashboards and filters. A dashboard helps the user to filter and manipulate data visualizations and explore different trends and insights is
- **Statistical Visualization** Statistical visualization is used to present data to show statistical properties, such as distribution or correlation. Histograms, box plots, and scatter plots are popular choices.
- **Information Visualization** Information visualization is used to present complex data sets in an easier way, often for abstract or conceptual data. Network diagrams, tree maps, and word clouds are effective tools. For example, a network diagram showing relationships between entities, such as a social network.
- **Business Intelligence:** Data visualization helps to make data driven, well informed decisions. It is used to find market trends and helps to track and improve performance.
- **Database** is collection of related data stored in the form of tables. Various computer software is used to create databases to store data in organized form so that it can be managed, retrieved and stored efficiently.
- **Data science life cycle** is an iterative process. It has various stages; each has certain steps to be taken to move forward. It requires a structured approach to solve data driven problems.
- **Problem Definition:** At this stage the business problem or research question is defined with clear objectives and outcomes. The scope and limitations of the problem are determined.
- **Data Collection:** At this stage, data is gathered by using various available, reliable and useful sources. The way data is collected depends on the kind of problem. For simple problems, we can observe and write down what we see, while more complex problems might need surveys, experiments etc.
- **Data Cleaning:** Also called data preprocessing, this step is about fixing the data to make sure it's ready for analysis. Any errors, such as wrong information or duplicates, are corrected or removed. Missing values, which might cause problems, are either filled in with estimated values or taken out altogether.
- **Data Analysis:** After cleaning the data, we have to analyze it. This is done using tools like statistics or machine learning techniques, which help in finding patterns, trends, or important details.
- **Data Modeling:** In this stage, the data is organized into a model, which is a structure that represents the data and how different parts relate to each other. This could involve creating diagrams that show the relationships between different entities (like customers and the products they purchase) and their attributes.

Exercise

Q1. Select the best answer for the following MCQs.

- Which of the following is the primary benefit of integrating Mathematics and Statistics with Computer Science in Data Science?
 - Improved data visualization
 - Better forecasting
 - Increased accuracy
 - Better decision making
- Which of the following best describes the relationship between Data Science and Artificial Intelligence?
 - Data Science is a subset of Artificial Intelligence
 - Artificial Intelligence is a tool used in Data Science
 - Data Science and Artificial Intelligence are unrelated
 - Data Science enables Artificial Intelligence
- The Turing Test, proposed by Alan Turing in 1950, measures a machine's ability to exhibit intelligent behavior. Which of the following is the fundamental assumption underlies this test?
 - Humans are better
 - Machines are equal
 - Intelligence levels vary
 - Machines copy humans
- Which of the following should be considered critically while developing AI-powered chatbots and virtual assistants?
 - User experience
 - Data security
 - Contextual awareness
 - Emotional intelligence
- What ethical consideration arises from the integration of Artificial Intelligence (AI) into daily life devices?
 - Job displacement due to automation.
 - Increased energy consumption.
 - Improved customer service.
 - Enhanced data security.
- Which of the following fields of Artificial Intelligence (AI) enables smartphones to recognize faces and unlock devices?
 - NLP
 - Computer vision
 - Deep learning
 - Neural networks
- A company wants to develop a system that categorizes customer feedback into positive, negative, or neutral. Which learning model would be most suitable?
 - Supervised learning
 - Unsupervised learning
 - Reinforcement learning
 - Deep learning

Q3. Write answers of the following extended response questions.

1. Analyze the interrelationship between Data Science, Machine Learning, and Artificial Intelligence.
2. Identify any three types of data visualization, give their applications as well.
3. Discuss the way data visualization can be used to communicate data uncertainty, provide two specific examples.
4. Describe the key considerations in selecting appropriate visualizations for different types of data and analyses?
5. Explain the uses of data visualization in detail
6. What are the potential consequences of poor data quality on model performance?



Activity-1

Predicting Pet Preferences:

Objective: To help students understand the usage of data science, machine learning and artificial intelligence by analyzing and predicting pet preferences in their daily lives.

Make the groups of students, to collect data from younger kids on their preferences about pet. The students will collect the age and gender of the younger kids and write down their preferred pet, which they want to have.

Ask the students to calculate the mean median and mode of the collected data after cleaning data and removing errors or duplication from their collected data.

Create a bar graph or pie graph to display the results and ask them to apply ML and AI on it.

Guide them to use a simple algorithm like decision tree to predict the pet preference for new data. For example, take the age and gender of a new kid which was not part of the survey, apply the algorithm and predict that which pet would be preferred by this kid. Compare the results with the actual choice of the kid.

To apply artificial intelligence concepts, ask them to imagine virtual pet assistant, that uses AI to suggest a pet based on the kids' preferences.

Outcome: This activity will help students with the implementation of machine learning, data science and artificial intelligence in daily life.



Activity-2

Visualize Favorite Foods:

Objective: To help students understand significance and application of data visualization to understand and compare data. They will learn how to find the opinion of people if they want to start some business somewhere.

Make the groups in the class, each group may contain 3 to 4 students. Ask them to conduct a survey of students' favorite food like biryani, nihari, pizza, ice cream etc. Each group will design different questions for the survey but overall it will be about food preferences.

Calculate the frequency of each food, like how many students like biryani, nihari, pizza, ice cream etc.

Ask the students to clean the data and create a graph best suitable for the collected data.

Let them visualize their data and check which food is more popular.

Let them compare the results of one group with the results of another group.

They will understand the differences in the results based on the differences in the questions.

Outcome: This activity will help students understand how data visualization is helpful to start some food business in some area. They will also learn that their results may vary depending upon their questions and methods of data collection.



Activity-3

Churn Prediction:

Objective: To help students understand how churn prediction can be helpful for any business.

This activity can be assigned to the students on an individual basis. Ask them to choose the business being conducted by some of their family member or someone in their friends' circle.

Students will collect the data about the products or services provided by the business they chose.

They will collect data about the customers as well.

By following the method explained in the case study given in this unit, they will make predictions about the customers who are likely to stop taking the product or services from that business.

Students will design affordable business offerings for the potential customers who are likely to leave that business.

They will compare the results of their predictions. And improve their model if they can.

Outcome: This activity will help students understand usage of churn predictions.

5

Applications of Computer Science



Learning Outcomes

At the end of this unit students will be able to:

- describe uses and applications that are enabled by technologies like IoT and Blockchain.
- explain that AI can be applied to specific applications in areas like NLP, Robotics, Speech Recognition, etc.
- demonstrate the social implications of AI.

INTERNET
OF
THINGS

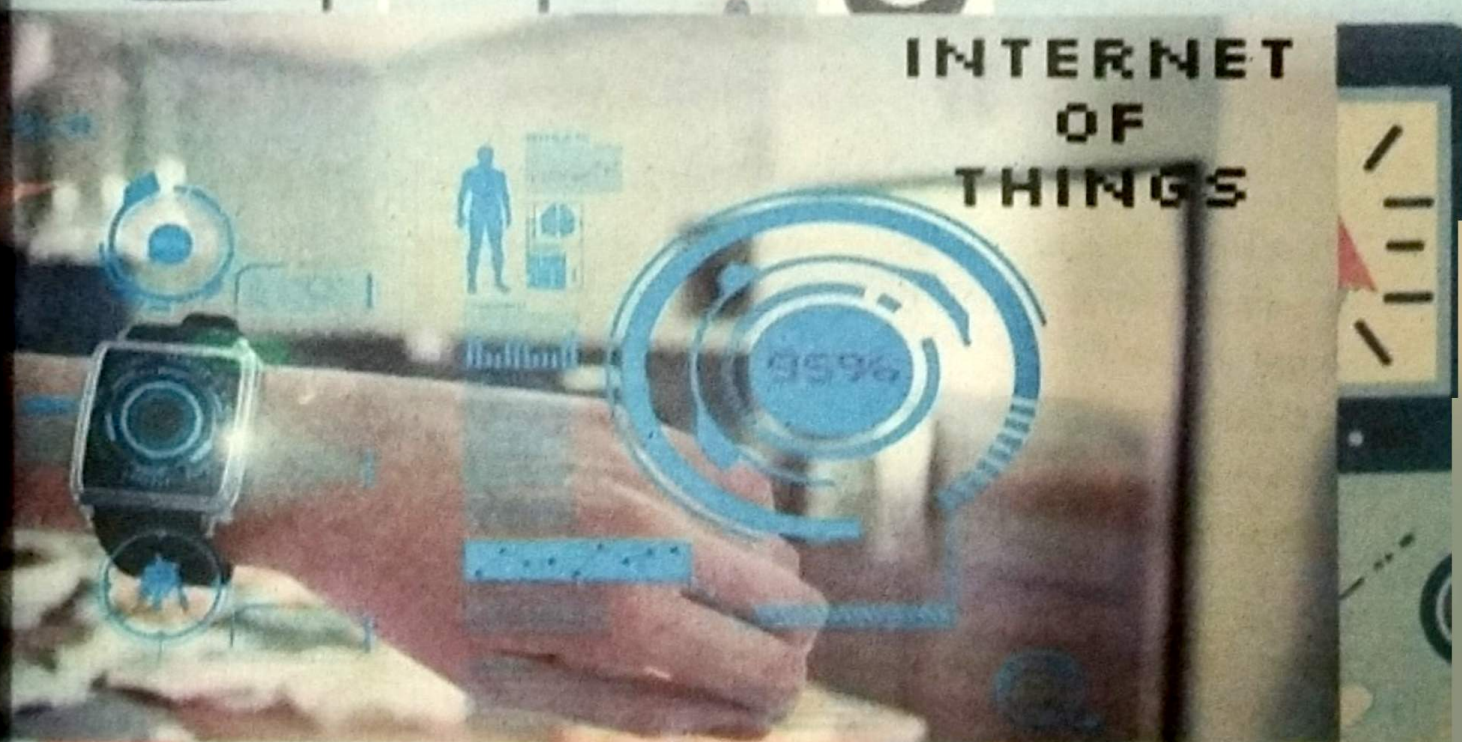

5.1 Internet of Things (IoT)

IoT is an infrastructure that consists of network of servers that provides connectivity between multiple devices and facilitates man to machine and machine to machine interaction. It collects data from multiple IoT devices, stores it in cloud storage and processes it using technologies such as data analytics and machine learning algorithms. The aim of IoT is to provide automation in various areas such as home automation, automation in manufacturing industry, healthcare, traffic monitoring, hospitality, etc.

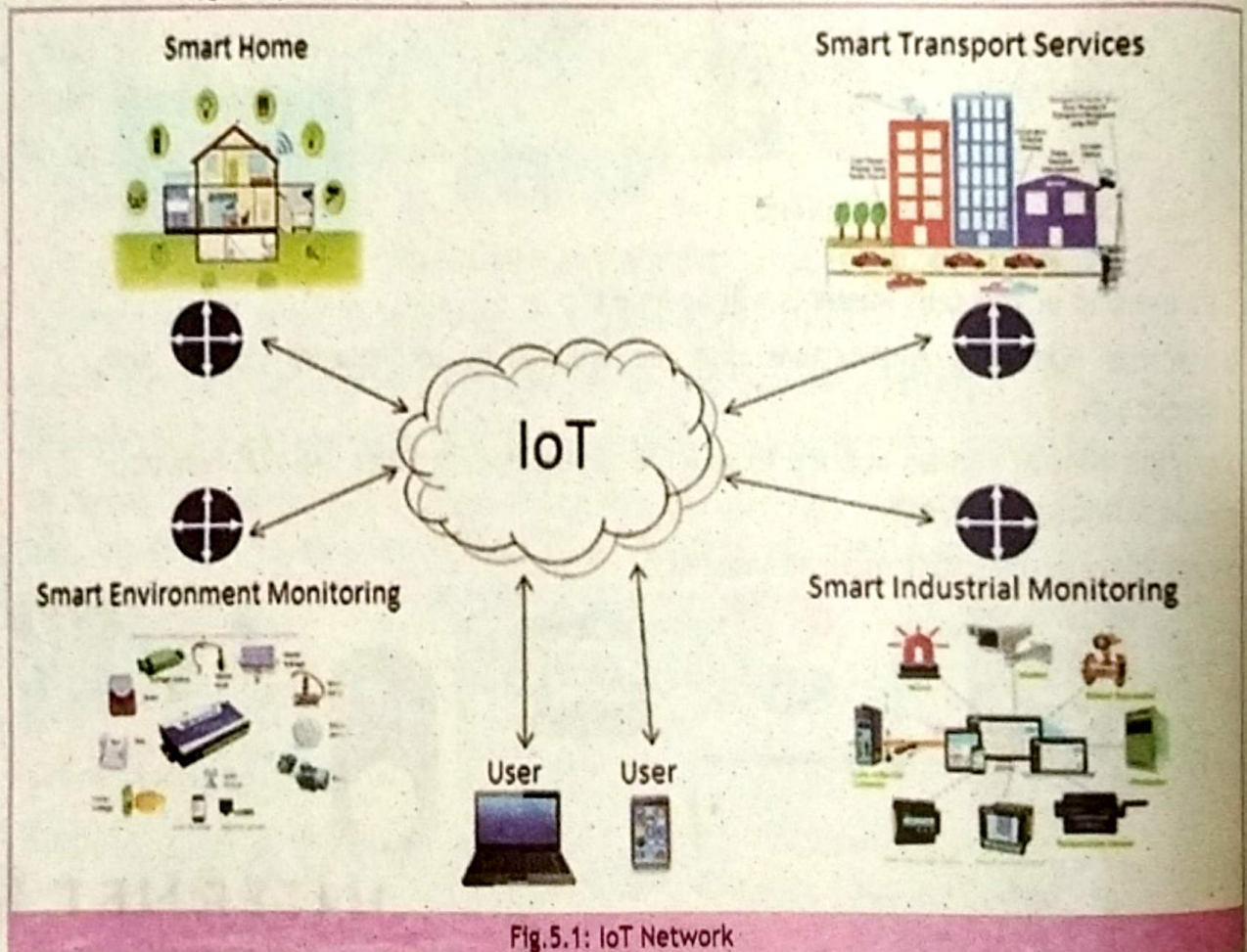

Fig.5.1: IoT Network

5.2 Foundational Components of IoT

There are five foundational components of IoT that make it work.

- Sensors/Devices
- User Interface
- Cloud
- Connectivity
- Data Processing

5.2.1 Sensors/Devices

Sensors or devices are used in IoT system to collect data from our surroundings. This data come from a large variety of sensors.

Some commonly used sensors are:

- Temperature sensors
- Humidity/Moisture level detection sensors
- Pressure sensors
- Light intensity sensors
- Proximity detection sensors

These sensors are simple ones but it can be complex as well such as surveillance camera paired with IoT devices like alarm to take action when criminal activity takes place. A device can be more than just sensing various types of data. For example, a smart phone is a device that has multiple sensors which include camera, light, proximity, temperature, heart rate, etc. A sensor can be a standalone device or a multiple device like a smart phone.



Fig.5.2: IoT based video surveillance



Fig.5.3: IoT based weather monitoring system

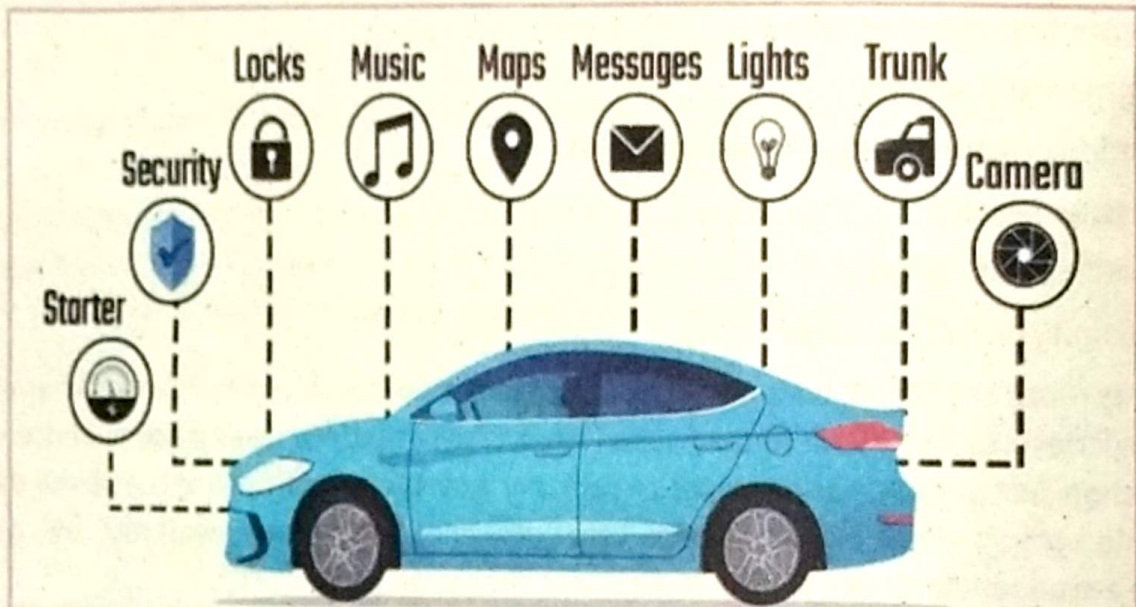

Fig.5.4: IoT application in automobile

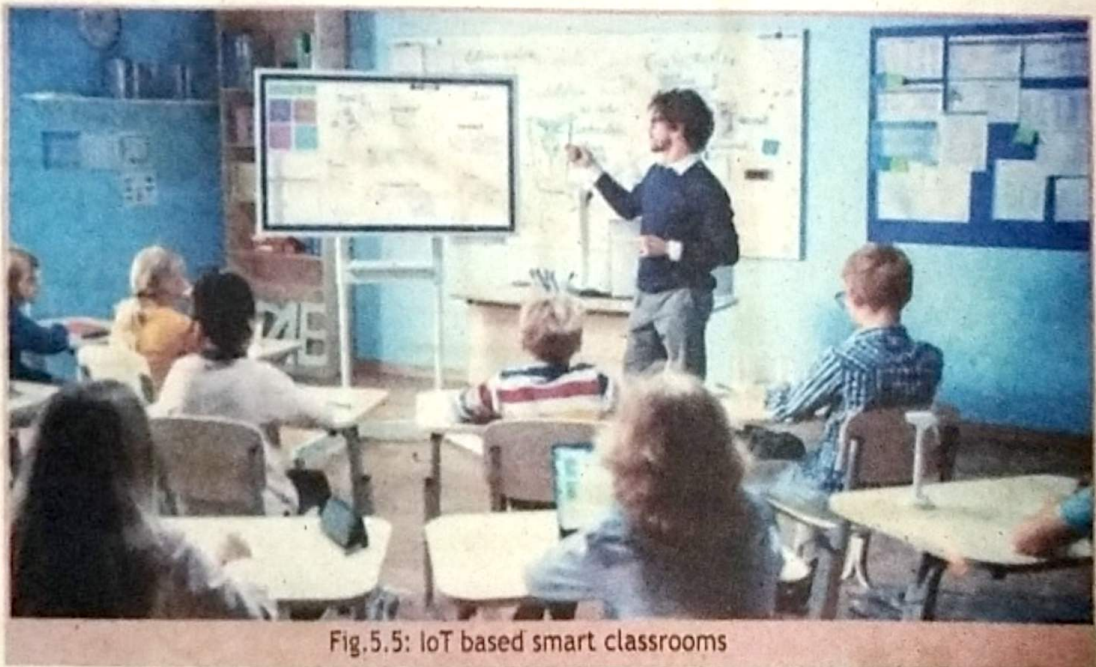

Fig.5.5: IoT based smart classrooms

5.2.2 User Interface

User interface provides user-friendly interface and functionalities that allows users to access and control the IoT devices.

For examples, a user has a camera installed in his home, he can check the video recordings through a web server. As another example, in case any intruders are sensed, the IoT system can generate an alert to the owner.

5.2.3 Cloud

The data collected from different devices is stored on the cloud storage. Cloud computing or cloud infrastructure is a set of servers that works continuously (24x7) over the Internet. IoT cloud is responsible for data collection from devices, processing of data and management. The data can be accessed remotely from the cloud storage at any time by the users to take decisions.

IoT cloud is a network of servers that efficiently handles data at high speeds for a large number of devices and analyzes it.

5.2.4 Connectivity

The data collected by IoT has to be sent to the cloud infrastructure through some type of communication media. Devices are connected to the cloud through cellular networks, satellite networks, Wi-Fi, Bluetooth, Wide Area Network (WAN), etc.

5.2.5 Data Processing

Data processing is the process of analyzing and interpreting the data stored in the cloud storage using software. Data processing is responsible for receiving raw data from the IoT devices, processing it and making it available for action. A variety of technologies such as analytics platforms and machine learning algorithms are used for data processing.

Do you know?

An analytics platform is an integration of multiple application software that provides comprehensive capabilities to connect, organize, visualize and analyze data. It helps organizations to build their strategies based on data.

Do you know?

Machine learning algorithms are computational models that allow computers to understand data patterns and make decisions or predict output based on it. These algorithms form the foundation of artificial intelligence.

5.3 Applications of IoT

The following are common applications of IoT.

5.3.1 IoT Wearables



Fig.5.6: IoT Wearables

Many small wearable devices equipped with sensors have been developed by many companies for measurements and readings of users' data. Some examples include wearable bands used for monitoring heart beat rate, calorie expenditure and GPS tracking belts. Samsung, Apple and Google have developed many wearable Internet of Things that are used in our daily life.

5.3.2 Healthcare

Special IoT devices are used in hospitals to enhance the quality of healthcare services for patients. In modern hospitals smart beds are used that are equipped with various types of sensors to observe vital signs of patients in real-time. These sensors continuously monitor patient's vital signs such as blood pressure, oxygen level in blood, temperature, etc. and alert the nurse or doctor to urgently attend the patient if needed. Wearable sensors are also connected to patients outside the hospital that allow doctors to monitor them in real-time.

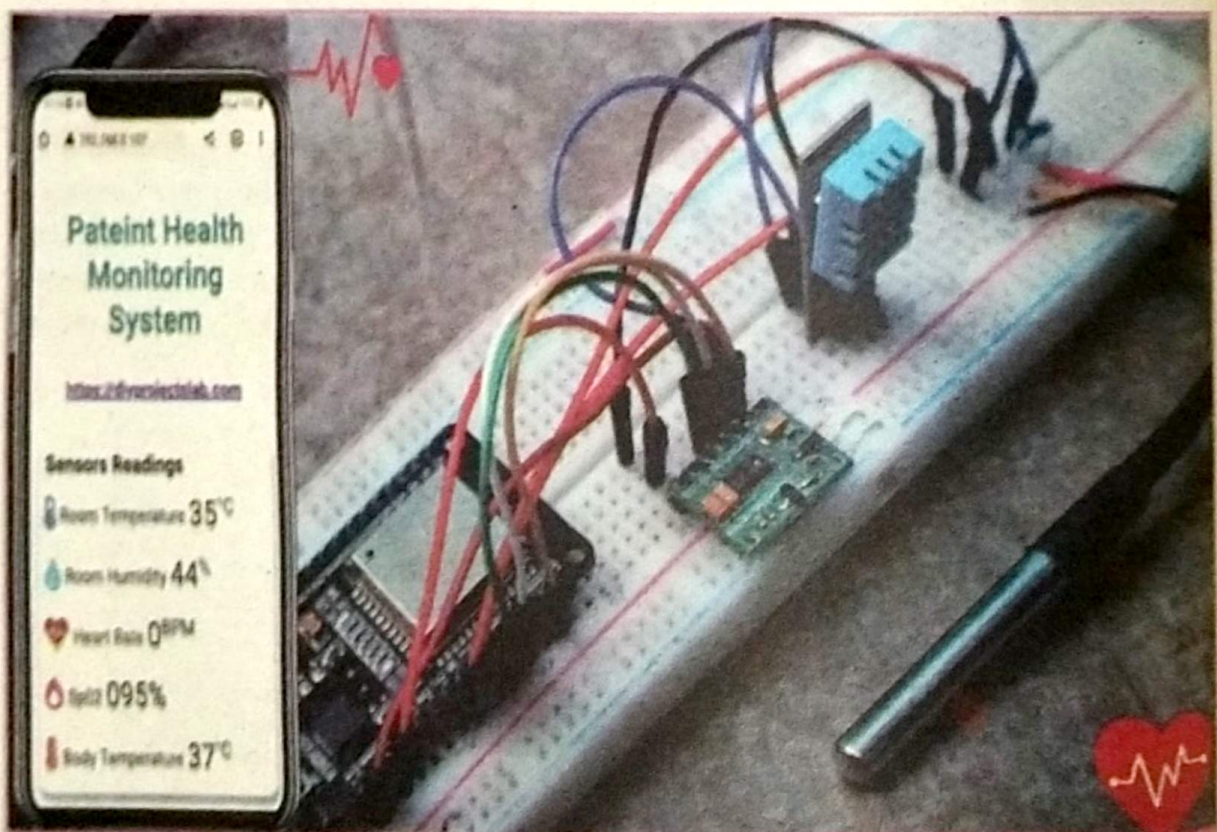

Fig.5.7: IoT based Patient Health Monitoring System

5.3.3 Traffic Monitoring

Traffic jams have become a big issue in big cities. IoT allows authorities to monitor and analyze real-time traffic data. It helps in improving the flow of traffic in areas with congestion and ensures road safety for drivers. Cameras and sensors are used to detect accidents, vehicle breakdowns and road hazards. The traffic data collected by IoT devices is transmitted to the traffic management control center for quick action to resolve issues. Moreover, IoT devices provide real-time updates on weather conditions for safety of drivers.



Fig.5.8: IoT based traffic monitoring

5.3.4 Hospitality

Smart hotels are using IoT technology to improve the quality of services for guests by automating many things.



Fig.5.9: Robot providing service in hotel room

The following are some applications of IoT in hotels.

- Some hotels are staffed with robots that help in performing various tasks such as cleaning rooms, transporting guest's luggage, providing location-relevant information, etc.
- Hotels use sensors to detect when the guest enters the room and automatically adjust the room temperature and lighting.
- Sensors can detect whether the guest is in the room or not. When he leaves, appliances used by him are automatically switched off, saving electricity.
- Using IoT technology, hotels can automatically send a digital key to guest's mobile phone that can communicate with the door to open or close. It is also a security feature enabled by IoT.

5.3.5 Industrial Automation

There are various applications of IoT technology in automation of various tasks in industry. These tasks include quality control, product flow monitoring, supply chain optimization, inventory management, packaging of products, safety of products, etc. IoT sensors can collect and analyze data on machine performance, temperature, vibration and other factors. Application of IoT in industrial automation has enhanced efficiency, productivity and safety in manufacturing.

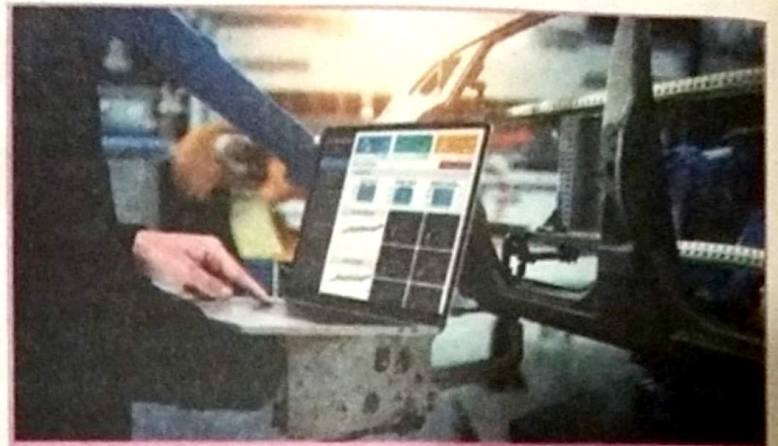

Fig.5.10: IoT in automotive industry

5.3.6 Smart Grid

Smart grids and traditional electrical grids use the same transmission lines, transformers, etc., for supply of electricity. The only difference is that smart grids use IoT devices that can communicate with each other and also with the consumer. It provides valuable information to the consumer about their electricity consumption and how they can reduce their electricity expenditure. Smart grids can monitor and analyze the production of electricity and make predictions when power supply may not be available. This will allow power companies to take quick actions to reduce chances of this happening. Traditional grids generate estimated bills whereas smart grids can generate more accurate as it measures electrical usage in real-time for each household.

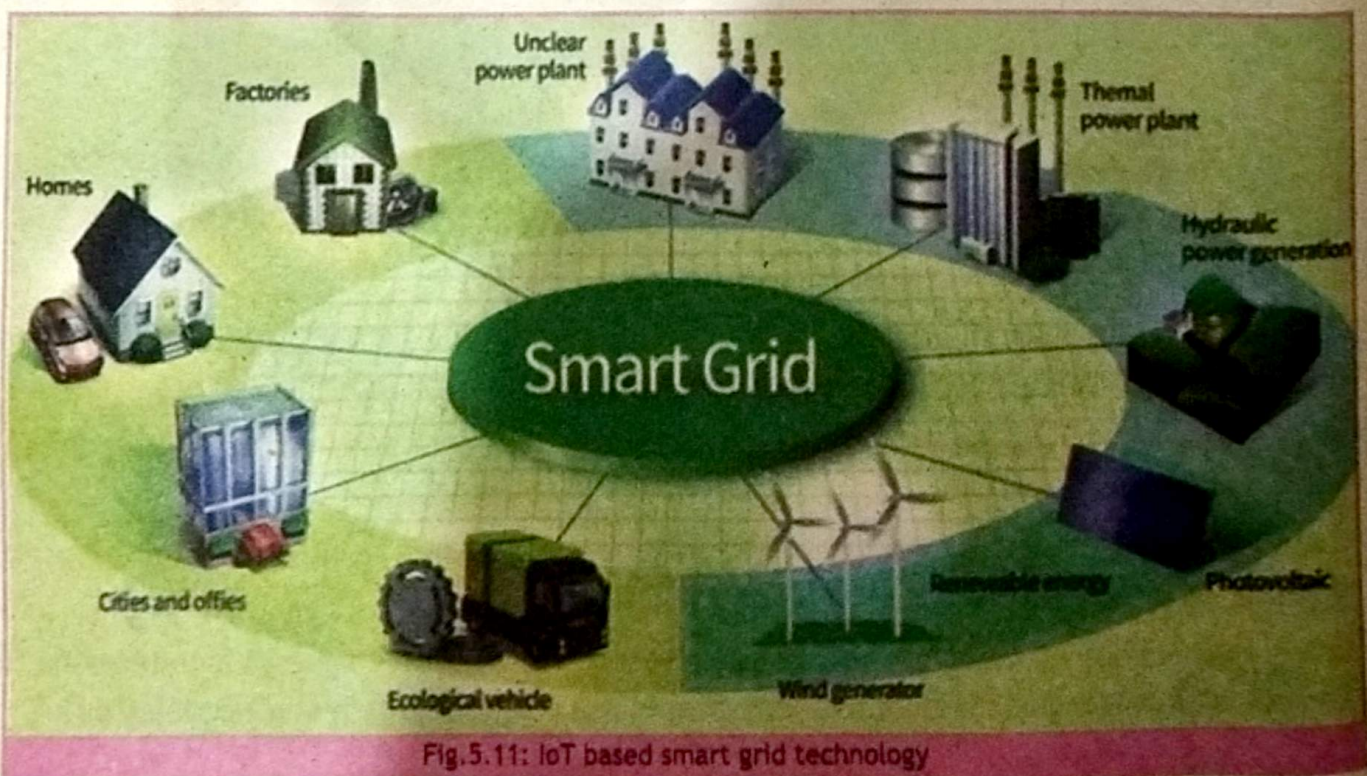

Fig.5.11: IoT based smart grid technology

5.3.7 Smart Farming

IoT-based smart farming uses various sensors that provide detailed information about soil condition to farmers. It uses sensors that monitor light, humidity, temperature, moisture, level of acidity, etc. Smart farming helps farmers control irrigation. It helps in making more efficient use of water, specify best time to start sowing and discover the presence of diseases in plants and soil.



Fig.5.12: IoT based Smart Farming

5.3.8 Smart Home

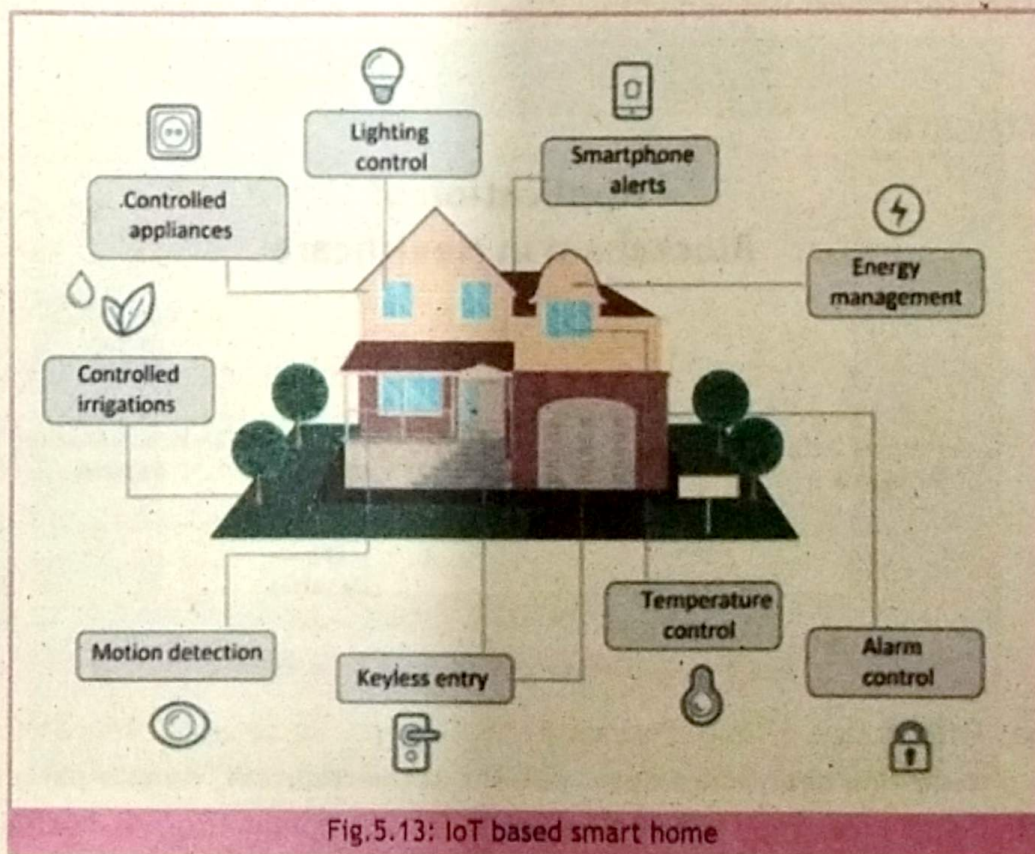

Fig.5.13: IoT based smart home

A smart home is based on IoT technology to provide convenience to home owners in using home appliances. All the appliances equipped with sensors are connected with each other to collect and share information and automatically perform specific tasks. The smart home system consists of devices such as smart light bulbs, smart security system having cameras, smart door locks, television, refrigerator, air-conditioner, etc. All these devices are remotely controlled using Internet connection from anywhere through an app installed on mobile phone, tablet or computer.

5.4 Blockchain Technology

Blockchain technology has become popular during the recent years. A Blockchain is a digital ledger or database of transactions that continuously grows. It is created, maintained and shared by network users. It plays an important role in cryptocurrency networks such as Bitcoin. It is very safe to use Blockchain for recording sensitive transactions as it is difficult to modify or delete the contents of a block (transaction) after it has been added at the end of the Blockchain. It also provides quick and easy transactions for individuals when needed.

5.5 Applications of Blockchain

The following are common applications of Blockchain:

5.5.1 Management of Supply Chain

Blockchain technology is very useful for real-time tracking of products during their journey across the supply chain. Blockchain helps in allocating the current location of products as products change hands between different parties in the supply chain. It also provides increased transparency and security as it is very difficult to change or delete contents of transaction data in the ledger.

5.5.2 Healthcare

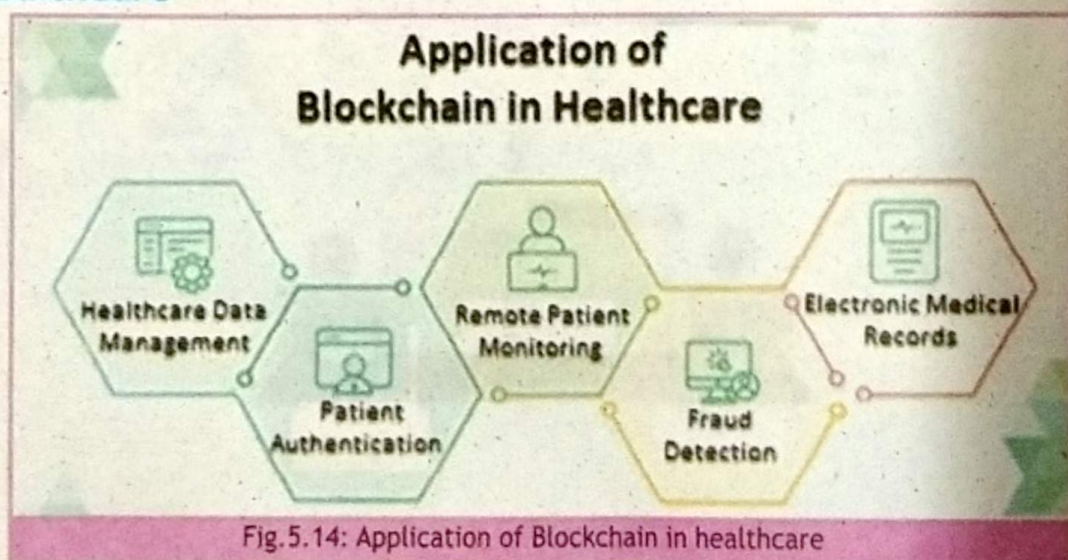

Fig.5.14: Application of Blockchain in healthcare

Blockchain has wide range of applications in healthcare. Some applications of Blockchain in healthcare are managing healthcare data, patient authentication, remote patient monitoring, fraud detection and electronic medical records. It is implemented in healthcare for data

Integrity, access control and data logging. Blockchain provides patient data security which aids in improving healthcare services in hospitals and research institutes.

5.5.3 Protection of Copyright and Intellectual Property

Blockchain technology makes it easy to protect copyright and intellectual property rights internationally on music, films, books, blogs and other internet contents as it operates globally. It is very useful in protecting people's creative work by making it easy to apply copyright regulations. It helps in reducing copyright violations due to its secure and transparent nature. Any type of unauthorized download of digital material can be traced easily.

5.5.4 Voting

Blockchain technology helps in building trust and satisfaction of citizens on Election Day and speeding the time for announcing the final results. It is useful in solving issues related with manual and digital voting systems such as voter privacy and fraud. Through encryption Blockchain makes voting safer, more transparent, protects privacy of voters and it is more cost effective as well. Application of Blockchain technology in voting is still under research.

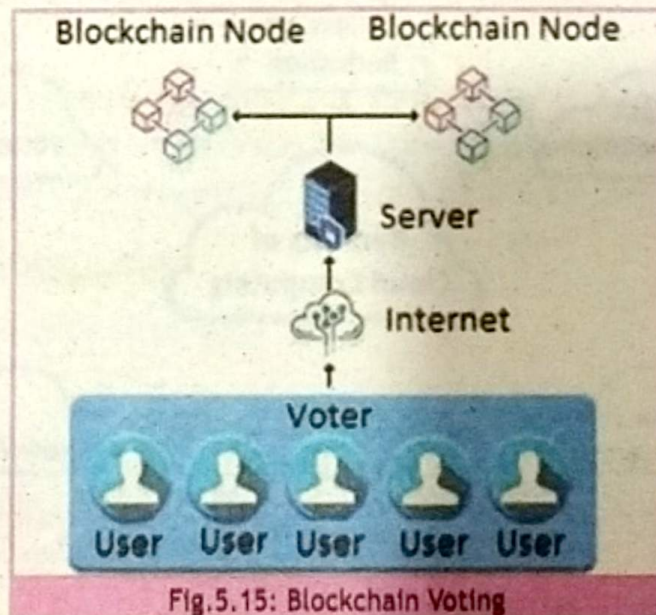

Fig.5.15: Blockchain Voting

5.5.5 Cryptocurrency

Blockchain technology has enabled the existence of cryptocurrency. Bitcoin is the best-known cryptocurrency. Cryptocurrency is a digital (or virtual) currency that facilitates direct payment without the involvement of intermediaries such as bank. It works through peer-to-peer global network without central clearing authority. Global peer-to-peer network is a worldwide network of computers in which all the computers have the same capabilities. In a peer-to-peer network, each computer can access the shared resources of other computers and share its own resources with other computers as well. In this type of network there is no need of a central computer or server. Cryptocurrency uses Blockchain technology to record and process transactions while maintaining transparency and security of financial information. Blockchain has the ability to improve business processes between companies by providing a direct and quick way of making payments.

5.5.6 Asset Administration

The key features of Blockchain technology such as decentralization, transparency and security create efficient and trustworthy system for managing assets. It is a new approach to managing digital assets. Digital assets means anything that is created and stored digitally, has value and ownership. Digital assets include photos, videos, books, cryptocurrency, music, illustrations, logos, etc.

Today, our lives are more digitally based. For example, when we are looking for information about anything, we turn to the Internet that stores digitally hosted information on any topic because it is easier and quicker than going to a library.

5.6 Cloud Computing

Cloud computing is the delivery of computing services such as servers, storage, database, networking and application software over the cloud (Internet). It is an alternative to on-premises computing in business. It enhances business productivity in various ways.

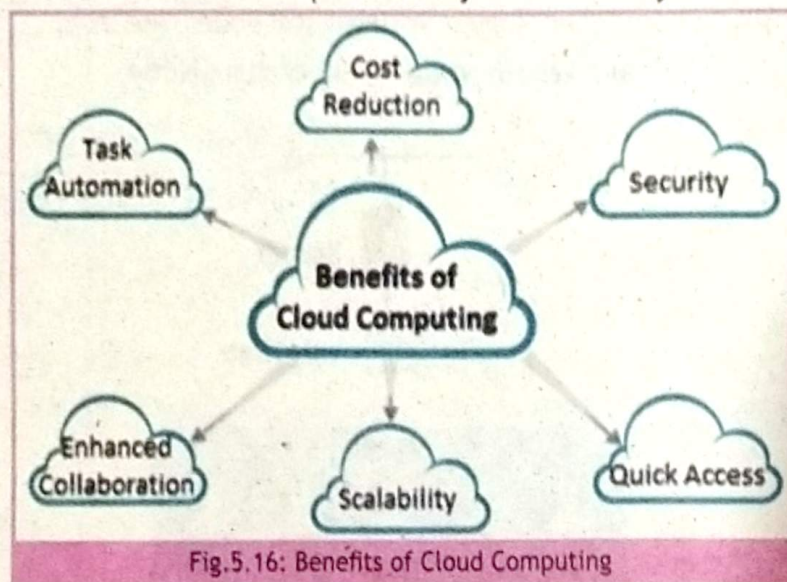

Fig.5.16: Benefits of Cloud Computing

5.6.1 Benefits of Cloud Computing

Cost Reduction

With on-premises computing, we have to purchase and install hardware, install the operating system and required applications and set up the whole infrastructure. Cloud computing reduces huge cost of buying hardware, software and setting up the networking infrastructure. Besides, the cloud provider is responsible for the maintenance of hardware and software.

Security

Cloud providers provide better security than on-premises systems. Cloud service providers follow best security practices and take active steps to defend against modern-day cyber-attacks. It is the responsibility of cloud providers to update cloud systems, fix bugs and resolve security issues. Data stored in cloud storage is at low risk. Cloud providers can restore the data from backups maintained in cloud storage.

Quick Access

Cloud computing provides quick access to resources, within few clicks. Employees can easily connect to cloud services from anywhere using devices like smartphones, tablets and laptops. Clients and customers can also log in and access their information.

Scalability

Cloud computing allows businesses to scale up or scale down in response to the changing circumstances and requirements. If business grows and demands increase, the cloud capacity can be easily increased without having to invest in physical infrastructure. Scalability minimizes the risks associated with on-premises operational issues and maintenance.

Enhanced Collaboration

In cloud computing, employees have easy access to essential business information whether they are working in the same office or remotely, increasing productivity. It enhances collaboration among teams anywhere in the world at any time. This leads to more efficient and effective performance.

Automation of Tasks

Cloud computing helps in streamlining business operations. It allows automation of time-consuming tasks. Cloud-based tools and services can automate companies tasks like data backups and software updates, freeing employees to focus on more important business activities.

5.6.2 Uses of Cloud Computing

The following are the uses of cloud computing

File Storage

Files storage is the most common use of cloud computing. Cloud-based storage system enables users to store and access files from any location. All you need is an Internet connection. Cloud-based storage is secure and affordable.

Data Backup

It is essential for individuals, organizations and businesses to backup data for protection and recovery in case of disaster. Cloud computing provides solution to this. It allows users to backup important files to cloud-based storage systems. Data on cloud-based storage systems can be encrypted to make it impossible for hackers to access. Some examples of cloud-based storage systems are Dropbox, Google Drive, OneDrive, iCloud, and Amazon.

Education

Cloud computing has revolutionized education. It is very effective in teaching and learning process. Cloud computing platforms store course material such as assignments, videos and quizzes in the cloud. It enables students and teachers all over the world to access educational material from leading institutions from anywhere. Some examples of cloud-based education solutions are Khan Academy, Coursera, edX, and Google Classroom.

eCommerce

Cloud computing provides cloud-based solutions for buying and selling products and services over the Internet which is known as eCommerce. It provides fast and secure shopping to customers. Shopify, WooCommerce and BigCommerce are some examples of cloud-based eCommerce solutions.

Social Networks

Social networks are one of the most popular uses of Internet. Cloud-based social networking platforms allow users to connect and share information with friends, family and customers and form relationships. There are many social networking platforms. These include Facebook, WhatsApp, Instagram, Tiktok, YouTube, LinkedIn and X which is the new name of Twitter.

Communication

Cloud computing provides reliable, secure and cost-effective communication services over the Internet. It uses various methods for communication such as email, chat, voice, video conferencing and social media. Cloud-based communication services are provided by Microsoft Teams, Zoom and Google Workspace.

Gaming

Gaming refers to playing video games for entertainment and education. Cloud computing provides cloud-based gaming solutions. It provides access to a variety of high-quality games on any device and from anywhere. Some examples of cloud-based gaming services are Microsoft Xbox Cloud Gaming, Amazon Luna, PlayStation Plus Premium and Nvidia GeForce Now.

5.7 Speech Recognition and Voice Recognition

Speech recognition and voice recognition are two different technologies though they are closely related.

Speech Recognition

Speech recognition is a form of artificial intelligence. It is a software that converts human speech into text form or commands that devices can understand and respond to. It provides hands-free control of various devices and equipment. It provides an easy way to operate devices and some hands-free equipment is very helpful for disabled persons.

The software used for speech recognition is quite complex as it involves signal processing, machine learning and natural language processing. The output accuracy of speech recognition software may depend on the quality of original recording and the complexity of the language. After the conversion of spoken words into text, the user can further process the text to correct the mistakes by running it through spelling and grammar check.

Voice Recognition

Voice recognition software converts voice into digital data based on the user's unique voice characteristics. Voice recognition is a biometric system. It is used to verify a person's identity based on unique features of his voice such as tone, pitch, etc.

Both speech and voice recognition technologies are used for interaction between humans and machines. These technologies are used in various fields to automate various tasks, create convenience, save people's time and improve productivity.

The following are the applications of speech recognition.

5.7.1 Speech to Text Typing Applications (Dictation Software)

There are a variety of speech to text typing software which is also known as dictation software. Dictation software was used in the early days but they had little accuracy. Now, dictation apps are AI-based and give better results but still cannot provide 100% results. Dictation software is very helpful for people with disabilities as they can use it to type more easily.

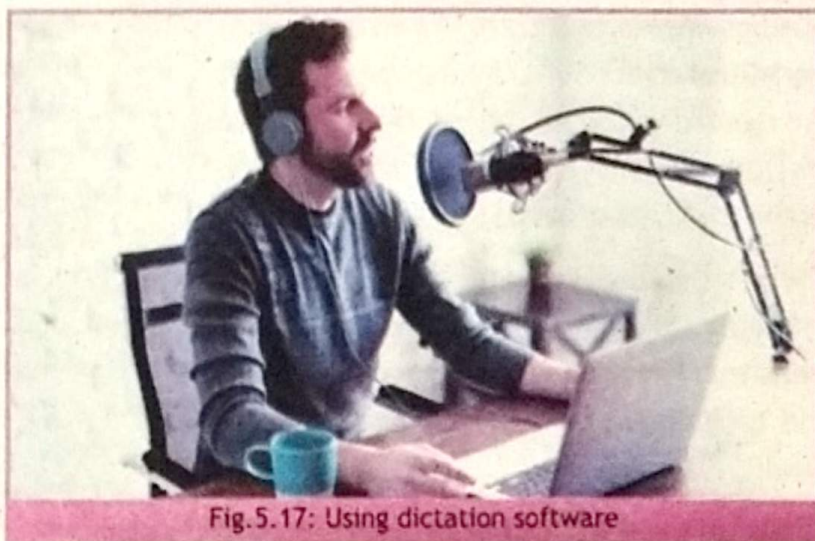

Fig. 5.17: Using dictation software

The following are some popular dictation software.

- Apple Dictation: It is a dictation software on Apple devices.
- Windows 11 Speech Recognition: It is a dictation software for Windows.
- Google Docs: It is a voice typing software for dictating Google Docs.
- Gboard: It is a dictation app for mobile phones.

5.7.2 Calls Centers

Speech recognition systems are used in calls centers to automate customer interactions. They are used to respond to customers' requests and improve productivity.

5.7.3 Healthcare

Automatic speech recognition systems are used in healthcare for efficiency and accuracy. Doctors use it to convert speech in to text for medical reports and updating patients' electronic health records.

5.7.4 AI Assistants

AI Assistants such as Siri, Cortana and Alexa are commonly used to help us in carrying out various tasks at home and at work. For example, AI Assistants can help us to turn lights on in our home, search for something on the Internet, give directions while driving and adjust thermostat. Thermostat is a device connected to central heating/cooling systems in homes and offices to control the temperature.

5.7.5 Quran Memorization Applications

Memorization of Quran is an important religious and spiritual practice in Islam. It is the Holy Book of Allah Subhanahu Wa Ta'ala and is reserved in the hearts of Muslims. Memorization of Quran is an act of worship and those who memorize it will get the reward in the hereafter. Memorization of Quran opens the doors of goodness, virtue, righteousness and morality.

There are many Quran memorization apps available on App Store, Google Play and websites. These apps use creative methods and techniques for easy memorization of Quran.

They provide features like audio recitation, interactive learning tools, progress tracking, selection of reciter and selection and repetition of verses. It can

also detect mistakes and provide feedback for correction. Some popular Quran memorization apps are Tarteel, Al Murqi, Quran Companion, Al Muhaffiz, Ayat-Al Quran and Quran Pro.



Fig.5.18: Ayat-Al Quran Memorization App

5.7.6 Language Translation

Speech Recognition systems are also used with machine translation software to convert human speech from one language to another. It helps to have conversation with someone who does not understand our language. It is very helpful for international business and organizations.

The following are applications of voice recognition.

5.7.7 Voice Recognition for Security

Voice recognition systems are used in various fields such as banking to recognize a specific voice for authentication and work as unique password to unlock protected account. The account cannot be unlocked by other people as their voice sound is different. Sometimes voice recognition is used along with facial recognition for identification of people.



Fig.5.19: Voice Recognition

5.7.8 Criminal Investigation and National Security

Voice recognition is used all over the world to solve crimes. If voice recording of a crime suspect is available, voice recognition technology can be used to provide evidence and identify criminals. Voice recognition can be helpful in investigating telephone-based fraud. It can also be used for surveillance of organized crimes on telephone and the Internet.

National security agencies use voice recognition technology to identify terrorist and government spies.



Fig.5.20: Voice recognition for criminal investigation

5.8 Natural Language Processing

Natural Language Processing (NLP) is a branch of Artificial Intelligence. It gives computers the ability to understand text and spoken words the same way humans do. Writing AI-based NLP software is extremely difficult task. The NLP software has to accurately understand the intended meaning of text or voice data for interaction between computers and humans. It is about making computers learn, process and manipulated natural language just like human brain.

NLP plays a growing role in increasing efficiency and productivity in business. It is very helpful in streamlining business operations and simplifying business processes.

The following are some common applications of NLP.

5.8.1 Email Filtering

We receive pile of emails every day which are related with our work, studies or many other things. Some emails are important to use and some promotional or spam. Spam is unwanted junk email sent in bulk. Spam can be advertisement, marketing message or even malware (malicious software) that can be harmful. The NLP email filtering software uses artificial intelligence to identify the incoming emails as important or spam and places them into their respective folders. This is done by detecting certain words or phrases in the emails that signal a spam message. Email filtering is not 100% accurate. Sometimes an important email is wrongly identified as spam.

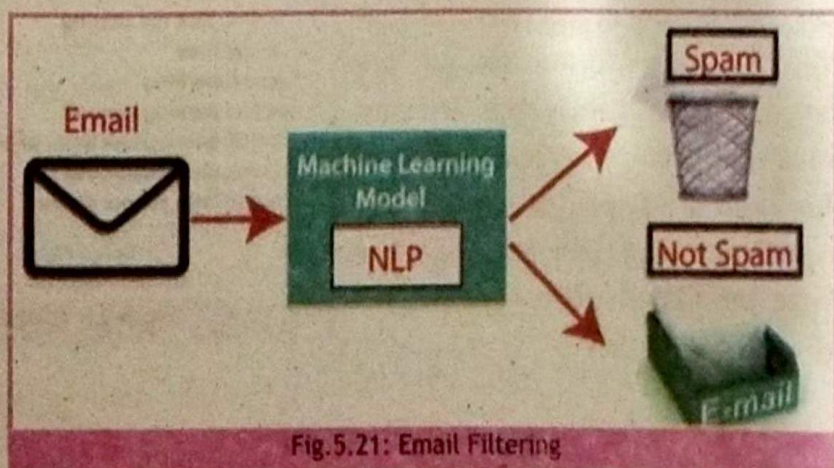

Fig.5.21: Email Filtering

5.8.2 Language Translation

NLP language translation software can translate written or spoken words from one language to another. It uses AI technologies known as Machine Learning (ML) and Deep Learning (DL). It is very helpful in removing language barriers. For example, it enables world leaders to participate in meetings where everyone speaks a different language. Here computer software and human interpreters work together to translate the speech into other languages. NLP programs can translate many other things such as books, business letters, websites, etc. and reduce cost of translation as well. The level of accuracy has increased as the technology is growing and advancing.

5.8.3 Document Analysis

Document analysis is an important application of NLP. Organizations, businesses, institutions and many such places have pile of documents stored in computers. The data stored in documents is properly organized, searched for and maintained using NLP. The NLP software extracts specific information from documents and categorizes it according to the user's requirements. It is very helpful in analyzing the data and making decisions and important predictions. It also helps in finding a person's information from pile of files.

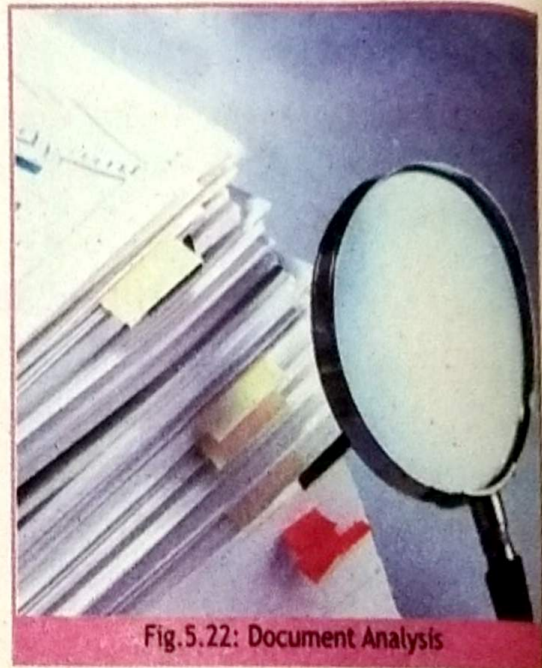

Fig.5.22: Document Analysis

5.8.4 Predictive Text

Making online searches is a very common task we perform on our smartphones and laptops. The NLP algorithms generate a list of predictive text, that is, probable next words or phrases as soon as we type anything in the search bar. We can click on any predictive text that matches the information we are looking for to display the relevant websites. Predictive text improves the search speed, enhances our experience and ensures that the suggestions align with our intention.

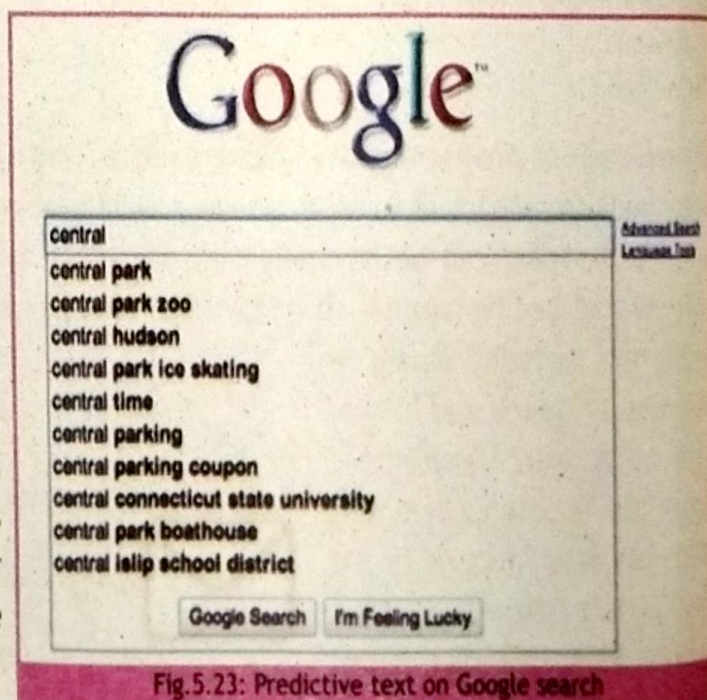

Fig.5.23: Predictive text on Google search

5.8.5. Sentiment Analysis

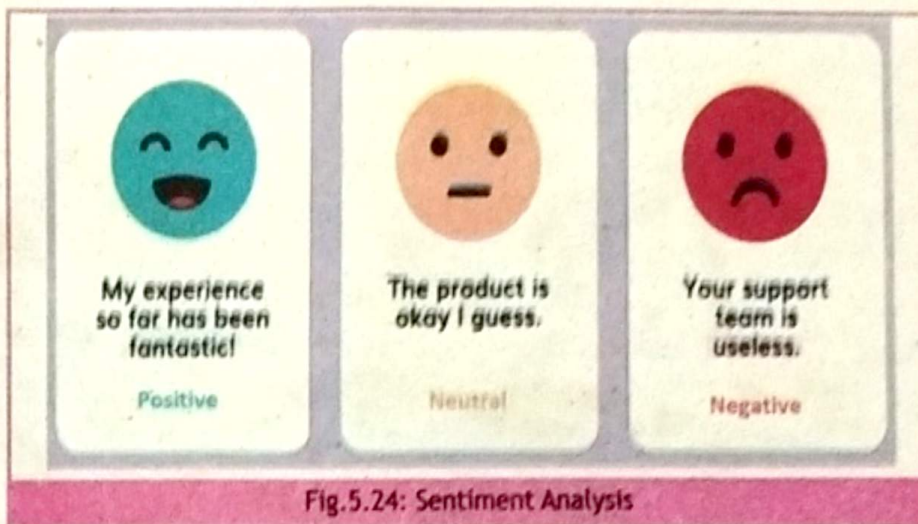

Fig.5.24: Sentiment Analysis

Sentiment analysis is an application of NLP technology to analyze text like humans and determine if the emotional tone of the message is positive, negative or neutral. Companies and business have huge amount of data like emails, reviews, social media comments and articles. Sentiment analysis on this data can be performed to identify the emotional tone of people and determine their opinions about a product, service or idea. For example, sentiment analysis can be performed on customer service to understand customer satisfaction levels and identify the areas for improvement. It can also be performed on a car model, smartphone or any other product to know whether people have positive or negative views about it.

5.9 Robotics

Robotics is a combination of artificial intelligence and engineering. It involves designing, creation and operation of automated machine programmed to perform tasks like humans. Over the years, robotics has developed sophisticated machines to assist humans in a wide range of industries all over the world.

The following are some applications of robotics.

5.9.1 Robots in Rescue Operations

Rescue robots are used for a variety of rescue operations. Firefighting robots are used to combat fire and rescue humans. Rescue robots are also used in natural disasters such as earthquakes, floods, landslides, hurricanes, cyclones and tornadoes to rescue people by searching, removing rubble, delivering supplies and medical treatment.



Fig.5.25: Rescue robot

5.9.2 Robots in Manufacturing Industries

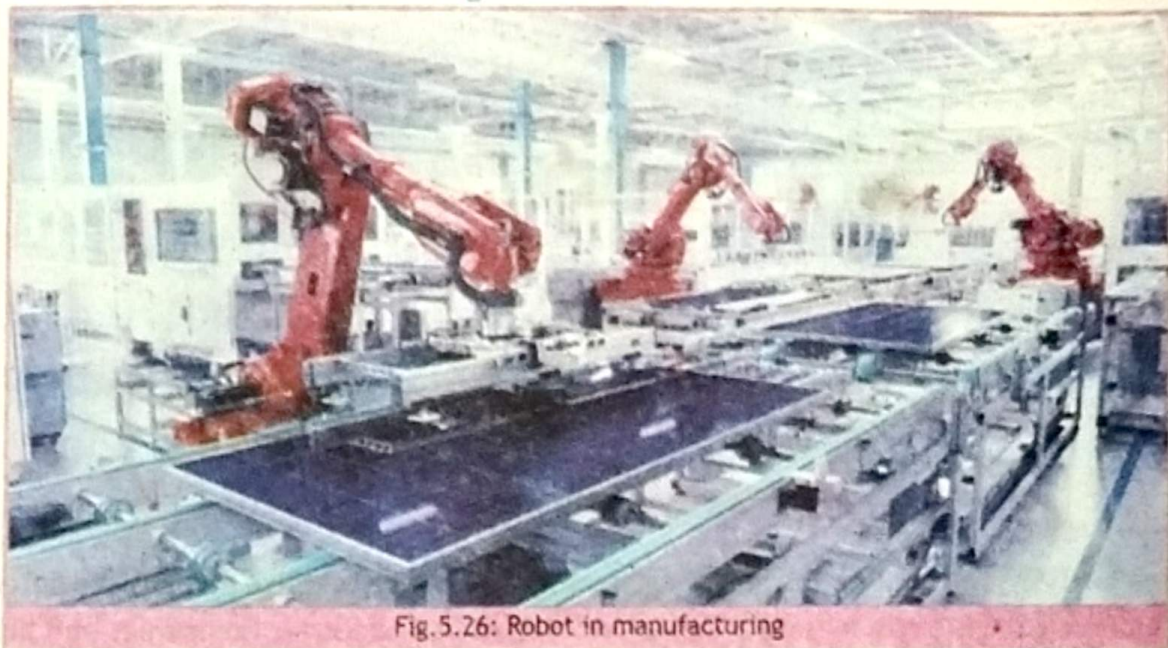

Fig. 5.26: Robot in manufacturing

Robots are used in manufacturing industry for automation of a variety of tasks. These tasks include assembly, welding, painting, product packaging, shipping, loading and unloading parts, etc. They are used to perform repeated tasks and to streamline assembly workflow. Robots replace human workers in some manufacturing industries performing dangerous tasks that may cause injury. Robots generally work in collaboration with human workers. Use of robots has increased productivity and reduced operation cost.

5.9.3 Roomba Robots

Roomba robot is a popular autonomous vacuum cleaner. It is a disk-shaped machine capable of picking dirt, dust, hair, etc. It is usually smaller than a traditional vacuum cleaner. It moves around the cleaning area and under furniture cleaning floors and returns to its dock when finished. While cleaning, it automatically turns away when approaching obstacles. Cleaning area boundaries can be set to restrict its movement. The direction of Roomba robot can be controlled by remote controller.



Fig. 5.27: Roomba Robot

5.9.4 Robots in Farming

Robots are used in farming for planting, harvesting, soil analysis, surveillance and monitoring. The purpose of using robots in farming is to reduce cost, optimize harvest and improve working conditions for farmers and workers.

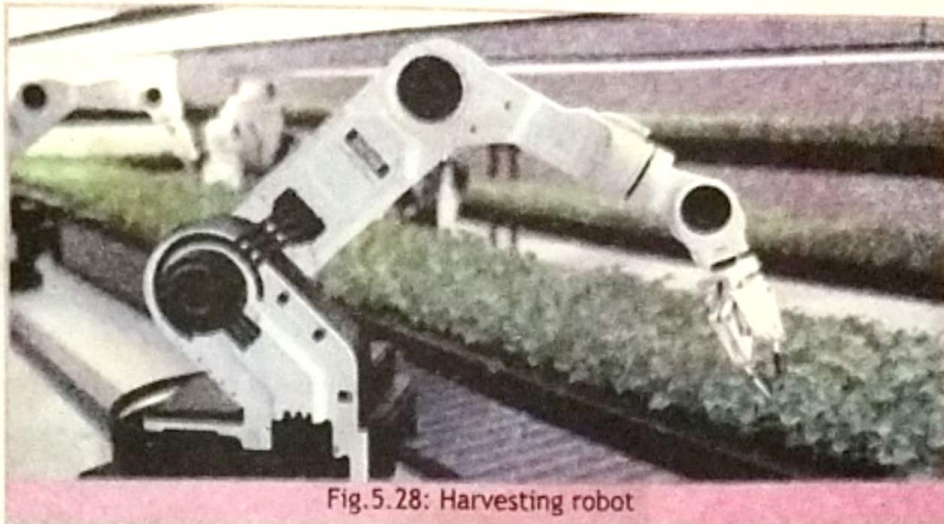

Fig.5.28: Harvesting robot

Various types of robots are designed and programmed to perform specific tasks on farms and agricultural environment.

- Robots developed for harvesting are used for picking fruits and vegetables.
- Spraying robots are used for spraying water and pesticides to plants that need it.
- Grafting robots automate the process of grafting, improve crop quality and reduce labor requirements.
- Palletizing robots are used for stacking and arranging harvest onto pallets for storage or transport.
- Drone robots are used to provide surveillance and monitoring.

5.9.5 Robots in Space Exploration

Robots play an important role in space exploration. Robots help astronauts in performing tasks such as collecting of soil samples, taking pictures of rock formation and sending them back on earth for scientists to study.

Robots help in repair and maintenance of spaceships and space vehicles millions of miles away from earth. Using unmanned space missions using robots are common today to learn about our universe. Robots can work in dangerous space environment as they don't need food, water or oxygen. They can work in extreme temperatures and radiation levels which is not possible for humans.

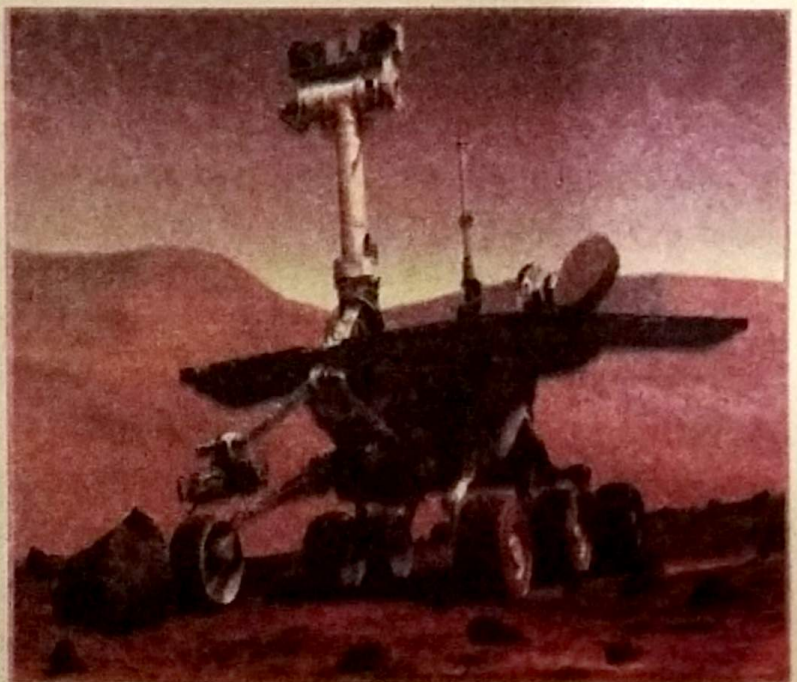

Fig 5.29: Robot in space exploration

5.9.6 Robots in Healthcare

Use of robots in modern hospitals is transforming the way surgeries and many other tasks are performed by healthcare professionals.

- Partially automated robots are used by surgeons to assist in performing high-precision operations in less time.
- Robots are used to replace healthcare professionals and perform their tasks in unsafe environment such as treatment of COVID-19 infected patient.



Fig.5.30: Robots used in operation room

- Automated Mobile Robots (AMRs) are used to sanitize hospital rooms and make them ready for patients.
- AMRs are also used to deliver medication and medical supplies and move heavy items such as beds.
- Hospital pharmacies utilize robots to store, pick and refill pharmaceuticals.

5.10 Bias and Unethical use of Artificial Intelligence

Artificial Intelligence has become integral part of modern society. It has brought positive impact in many areas of our daily lives but has some negative impact as well. Biased and unethical use of AI based systems has become a big concern all over the world as it can result in injustice to specific people. AI algorithms are developed by humans who can intentionally or unintentionally introduce bias in them. Bias means unfairness or discrimination against someone based on race, ethnicity, gender, age, etc. Unethical means something that is not morally correct such as unfair usage of AI related with violation of personal data or gaining unauthorized access to other's systems. AI based systems are not thoroughly checked for racial or gender biases. If the data used in training an AI system is incorrect, impartial, incomplete or biased in any way then the resulting AI system can cause injustice, hurt people and cause harm.

In, 2015, Amazon realized that their AI algorithm used for hiring employees favored men over women. The reason for this injustice was that the algorithm was based on the number of resumes submitted over the past ten years mostly belonged to male applicants.

As another example, it was observed that the facial recognition technology has sometimes produced wrong results for people with darker skin tones. This can cause injustice to people who are misidentified by the system in a criminal investigation.

The following are some examples of bias and unethical use of AI systems.

➤ Privacy Breaches

Privacy breaches are concerned with the violation of protection of personal data. AI systems have the ability to store and process huge amount of data which is vulnerable to privacy violation.

➤ Social Manipulation and Misinformation

AI systems can spread propaganda and manipulate social media trends such as peoples' likes and dislikes or changing their opinions related with all the aspects of society.

➤ Cyber Security Threats

AI system can employ techniques that can be used in cyber-attacks to gain unauthorized access to other's computer systems. This can lead to financial loss, privacy invasion or identity theft.

➤ Financial Market Manipulation

AI systems can be used to manipulate stock market that can lead to economic instability.

➤ Deepfake Videos

Deepfake videos are computer created AI based realistic fake videos. These videos misrepresent someone or saying something that was not actually done or said. Such videos can spread misinformation, defamation or change public opinion.

5.11 Responsibilities of AI System Designers

AI technology is shaping the future of humanity. It improves efficiency and provides innovative solutions in various sectors of our society. The designers of AI systems must keep in mind the ethical and social responsibilities while developing AI systems.

The following are the responsibilities of AI system designers:

➤ They must ensure that the use of AI technology does not result in injustice to specific groups of people.

➤ They are responsible for safeguarding user data privacy. The use of AI systems should not endanger people's privacy.

➤ AI system designers must ensure fairness, transparency and impartiality while developing AI algorithms.

➤ They should take into considerations the ethical values to prevent harm to anyone.

➤ They should ensure that the use of AI systems benefits humanity and improves people's quality of life.

➤ They should ensure that AI systems are designed to gain the trust of people and shape our future in positive direction.

Unit Summary

- IoT is an infrastructure that consists of network of servers that provides connectivity between multiple devices and facilitates man to machine and machine to machine interaction.
- IoT cloud is a network of servers that efficiently handles data at high speeds for a large number of devices and analyzes it.
- Smart grids and traditional electrical grids use the same transmission lines, transformers, etc., for supply of electricity. The only difference is that smart grids use IoT devices that can communicate with each other and also with the consumer.
- Smart home is based on IoT technology to provide convenience to home owners in using home appliances.
- Blockchain is a digital ledger or database of transactions that continuously grows. It is created, maintained and shared by network users.
- Cryptocurrency is a digital (or virtual) currency that facilitates direct payment without the involvement of intermediaries such as bank. It works through peer-to-peer global network without central clearing authority.
- Cloud computing is the delivery of computing services such as servers, storage, database, networking and application software over the cloud (Internet).
- Speech recognition is a form of artificial intelligence. It is a software that converts human speech into text form or commands that devices can understand and respond to.
- Voice recognition software converts voice into digital data based on the user's unique voice characteristics. Voice recognition is a biometric system.
- Natural Language Processing (NLP) is a branch of Artificial Intelligence. It gives computers the ability to understand text and spoken words the same way humans do.
- The NLP algorithms generate a list of predictive text, that is, probable next words or phrases as soon as we type anything in the search bar.
- Sentiment analysis is an application of NLP technology to analyze text like humans and determine if the emotional tone of the message is positive, negative or neutral.
- Robotics is a combination of artificial intelligence and engineering. It involves designing, creation and operation of automated machine programmed to perform tasks like humans.
- Roomba robot is a popular autonomous vacuum cleaner. It is a disk-shaped machine capable of picking dirt, dust, hair, etc.

Exercise

Q1. Select the best answer for the following MCQs.

- The technology used for management of supply chain is known as:
a. IoT b. Blockchain c. Cloud Computing d. AI Assistant
- The technology that provides automation in manufacturing industry, healthcare, home, traffic monitoring, etc. is known as:
a. IoT b. Blockchain c. Cloud Computing d. Robotics
- The technology that is an alternative to on-premises computing in business is:
a. AI Computing b. Server Computing
c. Cloud Computing d. Network Computing
- Branch of AI that gives computer the ability to understand text and spoken words like humans is known as:
a. Language Translation b. Digital Language Processing
c. Robotics d. Natural Language Processing
- The technology that enabled the existence of Cryptocurrency is:
a. Cloud Computing b. Blockchain c. Robotics d. IoT
- The virtual assistant developed by Microsoft is:
a. Cortana b. Siri c. Alexa d. Bixby
- The probable next words or phrases that are displayed as we type anything in the search bar is called:
a. Document Analysis b. Sentiment Analysis
c. Predictive Text d. Internet Suggestion
- AI based realistic videos that are not genuine are known as:
a. Privacy Breach Videos b. Social Manipulation Videos
c. Misinformation Videos d. Deepfake Videos

Q2. Write answers of the following short response questions.

1. Describe how IOT can help traffic monitoring.
2. Describe the benefits of using Blockchain technology in maintaining a digital ledger (database) of transactions.
3. Differentiate between speech recognition and voice recognition.
4. Describe the features available in Quran memorization apps that help in the memorization of Quran.
5. Briefly describe how AI-based systems can cause injustice to some people.
6. Describe how predictive text based on NLP algorithms helps in making online searches.

Q3. Write answers of the following extended response questions.

1. Briefly describe the application of IoT in the following areas.
 - a) Healthcare
 - b) Hospitality
 - c) Smart farming
2. Briefly describe how Blockchain technology is useful in the following areas.
 - a) Management of supply chain
 - b) Voting
 - c) Protection of copyrighted and intellectual property
3. Describe any three benefits of cloud computing.
4. Describe the use of voice recognition for security and criminal investigation.
5. Briefly describe how NLP helps in email filtering and language translation.
6. Describe two applications of robots that are not mentioned in this unit.



Activity-1

Students should use online tools like Google Docs and Google sheets to show the benefits of cloud computing.



Activity-2

Present to students an IoT application like smart parking. Each parking spot has a sensor that can detect if the spot is occupied and users have applications that can check open parking spots in a parking lot or garage. The students are then presented with a scenario of a smart home with temperature sensors, fans and ACs that can be remote controlled from a smartphone, and other household items like umbrellas, lunch boxes, fridges that are connected. Ask students to imagine applications that are enabled in such an environment.



Activity-3

Students can watch different videos on how technology in different fields is automating tasks that were once done by humans.



Activity-4

Read or explain case studies of how AI has discrimination. For example, the COMPAS algorithm used in US course system. Amazon's hiring system was biased against women is another case study.

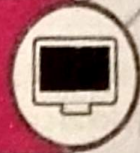

Learning Outcomes

At the end of this unit students will be able to:

- understand and apply safe & responsible use of the internet to prevent addiction, promote information and data security
- evaluate the impact of and apply strategies to prevent cyberbullying/harassment
- analyze the impacts of the digital divide on access to critical information



UNIT INTRODUCTION

Using the internet safely is very important today. This unit will help you learn how to be careful and responsible online. We will discuss here how to avoid internet addiction and keep your personal information safe. It is also important to protect your personal information. Using strong passwords, looking out for scams, and keeping your privacy settings updated can help protect you from online threats and keep your digital identity safe.

Spending too much time online can harm your mental health and lesser your productivity. By noticing when you are spending too much time online and finding ways to reduce it, you can keep a healthy balance in life.

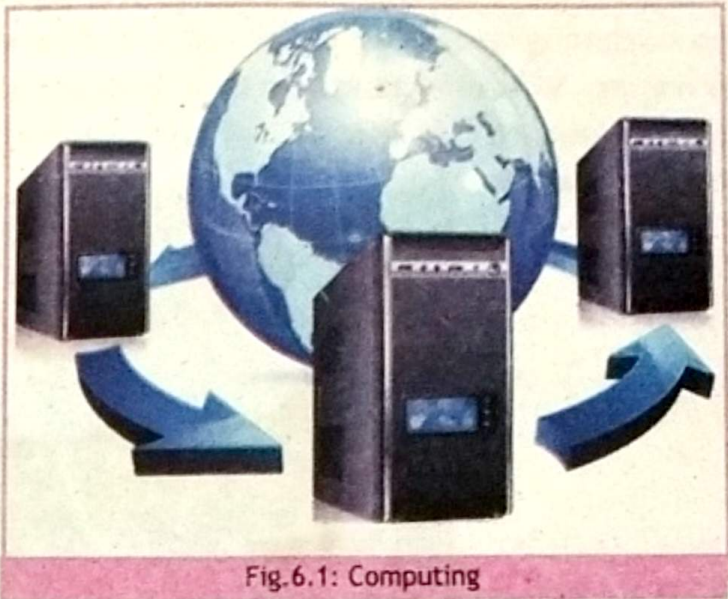

Fig.6.1: Computing

6.1 What is Technology Addiction

Technology addiction, also known as digital or internet addiction, refers to the excessive and compulsive use of devices like smartphones, computers, video games, and social media. This type of addiction can disrupt a person's daily life, relationships, and overall well-being, similar to other behavioral addictions like gambling or compulsive shopping.

Activities that often lead to technology addiction include heavy use of social media, online gaming, video streaming, endless web browsing, and constant texting or messaging. However, not everyone who uses technology a lot is addicted. The key difference is



Fig.6.2: Technology addiction

whether the technology use negatively affects one's life and if the person struggles to control it. Technology addiction is a serious issue that might require treatment through counseling, therapy, support groups, and strategies to use technology more responsibly.

Teacher Point:

In a remote village, Sara struggles to access online educational resources due to limited internet availability, while her friend in the city excels with high-speed connectivity. The teacher helps students analyze how the digital divide creates unequal opportunities, affecting access to critical information for education, healthcare, and job opportunities, emphasizing the need for equitable solutions.

6.1.1 Concern of technology addiction

Technology addiction is a rising question in today's world. It affecting people of all ages. Spending too much time on devices, social media, and games can make people excessively dependent on technology, which can harm both their mind and body. It is important to understand this problem and find ways to control technology use to keep a healthy balance between online activities and real-life relations.

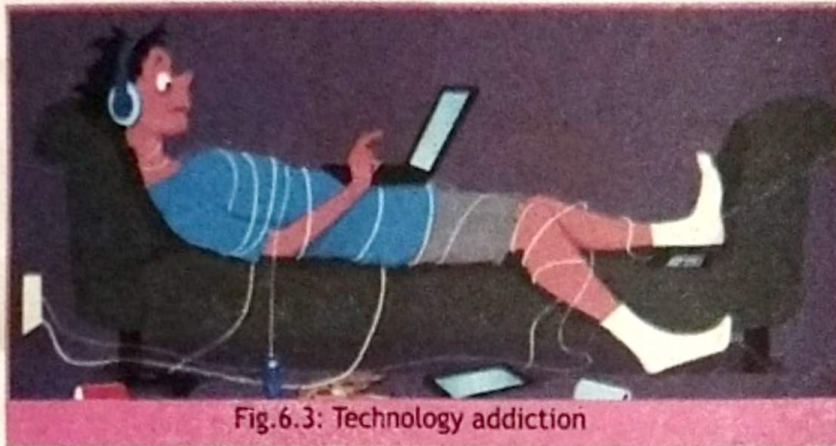

Fig.6.3: Technology addiction

Mental Health Challenges:

Depression and Anxiety:

Technology addiction can make feelings of depression and anxiety worse because always comparing yourself on social media, dealing with cyberbullying, and facing online harassment can hurt your mental health.

Isolation:

Excessive screen time can cause social isolation and loneliness. When people spend too much time on screens, they have less face-to-face interaction. Technology addiction can also harm relationships with family and friends. This happens because people may choose their devices over real conversations.

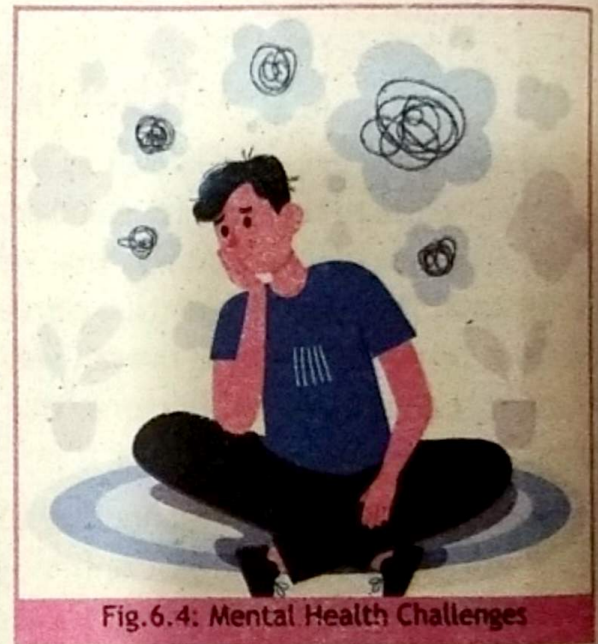

Fig.6.4: Mental Health Challenges

Academic and Occupational Problems:

Decreased Productivity:

Technology addiction can lead to decreased productivity at work or in school due to constant distractions.

Academic Underperformance:

Students addicted to technology may find it hard to focus on their studies, which can affect their grades and academic performance.

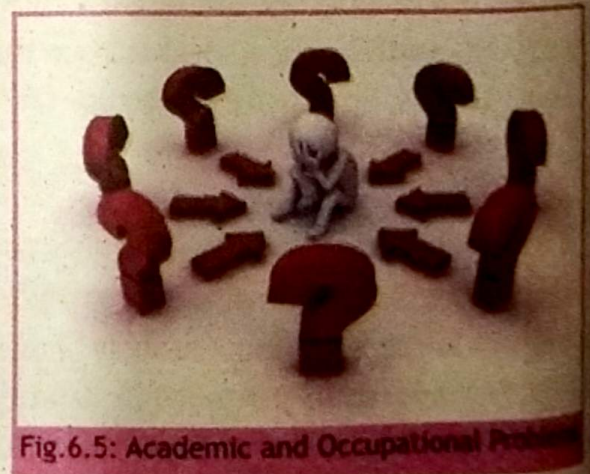

Fig.6.5: Academic and Occupational Problems

Privacy and Security Concerns:

Oversharing:

People who are addicted to social media might share too much personal information, which can put their privacy and security at risk.

Online Scams and Cybersecurity Risks:

People who are addicted to technology might be at higher risk of falling for online scams and cyberattacks because they spend too much time online.

Analyze the impact of new technology laws on digital privacy:

New technology laws have changed digital privacy and security in both good and bad ways. These laws, such as GDPR in Europe and CCPA in the U.S., help people control their personal information and require companies to protect data more carefully. They also help by making companies report data leaks quickly. However, finding a balance between privacy and letting law enforcement access data is tough and can impact people's privacy. For businesses, following these rules can be expensive, and different laws in each country make it harder to manage data internationally.

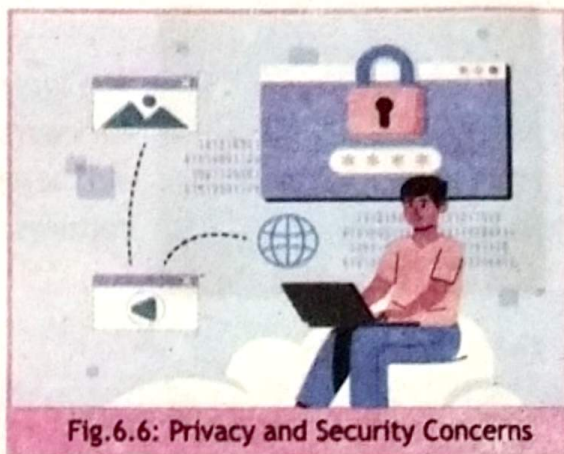

Fig.6.6: Privacy and Security Concerns

6.2 Internet

The internet is like a giant web connecting computers and devices everywhere. It allows us to share information, communicate, online buying and selling, and watch videos etc. Think of it as a massive library where you can find almost anything you want to learn. The internet has revolutionized how we live and work, continuously improving with new advancements. It is now a crucial part of our daily lives, making tasks quicker and simpler than ever before.

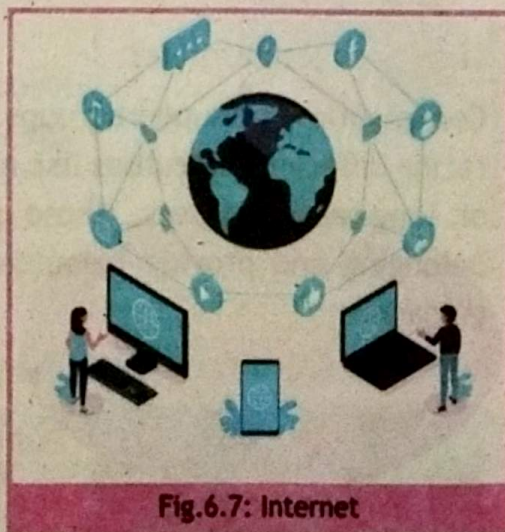

Fig.6.7: Internet

6.2.1 Use internet for beneficial purposes

Using the internet for good purposes like to help people and communities. This includes using online tools for learning, health, social interaction, and caring for the environment. The internet connects people, making it easy to share ideas and work together. This introduction explores how the internet can bring positive changes, inspire people, and improve lives.

Information and Education:

The internet provides access to a vast amount of information and educational resources. It has made learning more accessible through online courses, tutorials, and educational websites, enabling people to acquire new skills and knowledge.

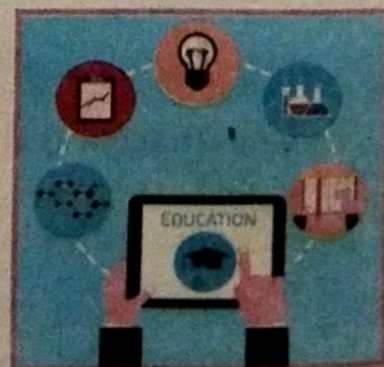



Global Communication:

The internet links people from all over the world, making it simpler for individuals to talk with family and friends who are far away. It has also helped people work together internationally and share different cultures.

Social Activism:

Social media sites and online groups have played a big role in making people more aware of social and environmental problems. Activities like climate change activism have become more popular and have made a difference because of online efforts.



Medical Information and Telemedicine:

Getting medical information and using telemedicine services online has made it easier for people to get healthcare, especially in areas where there are not many doctors or hospitals nearby. Patients can talk to healthcare professionals and find medical help online.

Support Communities:

Communities and support groups online are available for individuals facing different difficulties like mental health problems, addiction, or long-term illnesses. These groups give people a feeling of belonging and provide resources for those needing support and guidance.



Political Engagement:

The internet has boosted citizen involvement in politics by giving them places to chat about political topics, sign up for voting, and join in elections. Plus, it is made government actions more visible and open.

Cultural Exchange:

The internet allows people from different cultures to connect and share their traditions, art, and ideas. It promotes cultural understanding and appreciation.



Hate Speech and Disinformation:

Some individuals and groups use the internet to spread hate speech, misinformation, and disinformation, which can contribute to social division and tension.

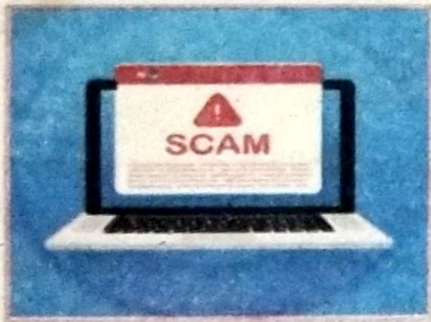

Online Scams:

Scammers often use the internet to trick individuals into giving away personal information or money through various fraudulent schemes including phishing (Phishing is a scam that tricks people into giving away personal information, like passwords, by pretending to be someone trustworthy) emails and fake websites (Fake websites are imitation sites designed to look real but are created to steal personal

information or spread malware).

Privacy Violations:

There are instances where the internet is exploited to invade people's privacy, such as by hacking into personal devices or leaking sensitive information.



Cyber Espionage:

Nation-states and other entities may engage in cyber espionage to steal sensitive information, intellectual property, and government secrets.

6.3 The Effects of Threats to Individual Privacy and Security

Threats to individual privacy and the security of data from spam, spyware, and cookies are significant concerns in the digital age. Each of these threats has distinct implications and can pose various risks to users:

Spam:

Spam emails usually have annoying ads or harmful stuff. If you receive spam, it could mean someone got your email without your permission, which can put your privacy at risk. Some spam emails even have viruses or try to trick you into giving personal info by clicking immoral links or downloading corrupt files. To deal with spam, you can use spam filters, be careful who



Fig.6.8: Spam emails

share your email with, and tell your email provider about spam. Using temporary email addresses for online stuff can also help avoid spam.

Spyware:
Spyware is software that spies on what you do on your device, takes your personal info, and sends it to unauthorized people. This invasion of privacy can lead to someone stealing your identity or money. Spyware can also make your device unsafe by letting people access important information. It can see what you type, take pictures of your screen, and remember your passwords. To stay safe from spyware, always update your antivirus and anti-spyware software. Do not download software from places you do not trust, and be careful with links and files you click on.

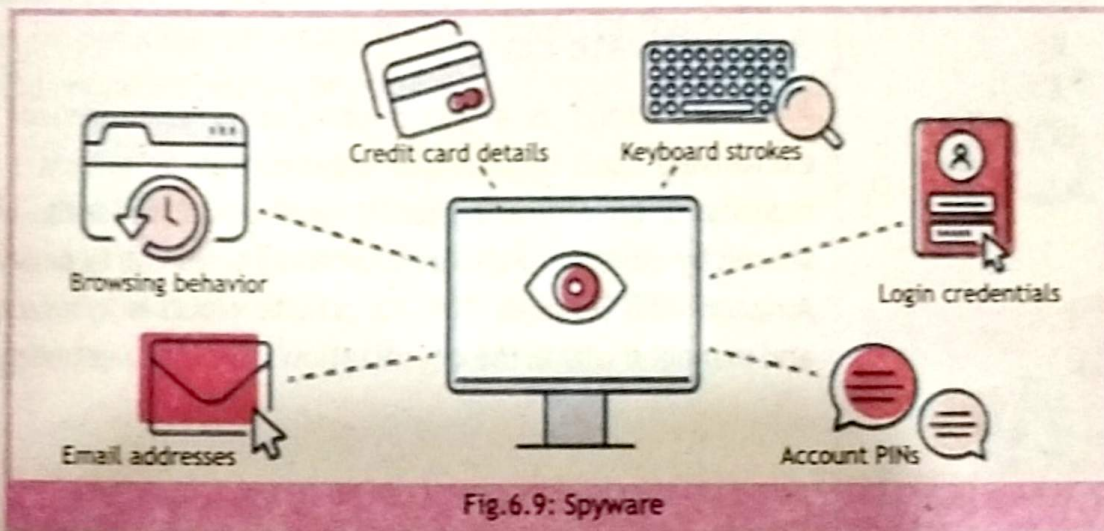

Cookies:
Cookies are tiny files saved on your device to remember what you do online. Some cookies are helpful, but others collect your information without asking, which is not good for your privacy. You can control and remove cookies in your web browser settings. Also, turning on settings to block cookies from other websites can help keep privacy safe.

6.4 Cloud Computing

Cloud computing is a way to use computer resources like servers, storage, and software over the Internet. Instead of having to buy and maintain all the hardware yourself, you can rent it from companies that offer cloud services. This setup has many advantages, like being able to change how much you use based on your needs, saving money, being flexible, and accessing your stuff from anywhere with an Internet connection.

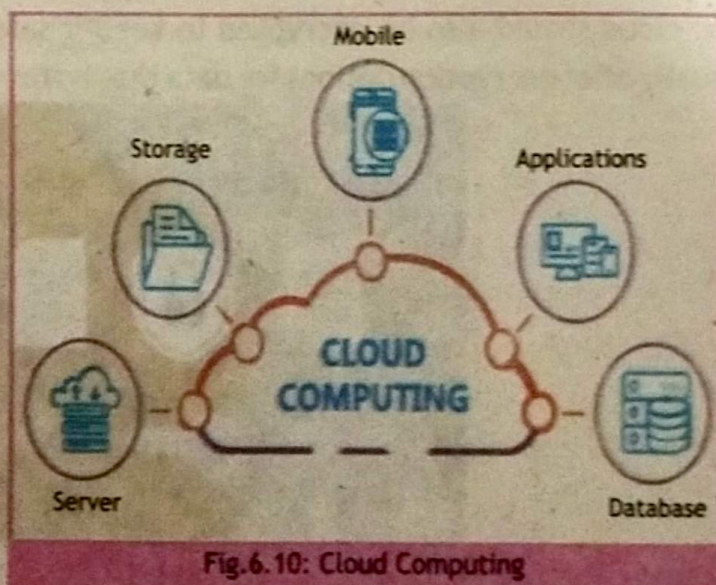

6.4.1 Public cloud

A public cloud is a type of cloud computing service that provides resources and services over the internet to multiple users and organizations. It is called "public" because the cloud infrastructure is owned and operated by a third-party cloud service provider and is made available to the general public or a wide range of customers. These cloud providers typically have vast data centers with a multitude of servers, storage, and networking equipment that they use to deliver various cloud services.



6.4.2 Private cloud

A private cloud is a cloud computing environment that is exclusively used by a single organization or entity, such as a business or government agency. Unlike public clouds, which are shared by multiple users and hosted by third-party providers, a private cloud is typically hosted and managed within the organization's own data centers. For example, Amazon Web Services (AWS) is a public cloud, while a private cloud is typically hosted and managed within the organization's own data centers.

6.4.3 Basics of security and privacy of cloud computing

Security and privacy are critical aspects of cloud computing. When using cloud services, whether for personal or business purposes, it is essential to understand the basics of how security and privacy are managed. Here are the key concepts and considerations:

Data Encryption:

Make sure that data sent to and from the cloud is encrypted using secure methods. Data stored in the cloud should also be encrypted to keep it safe from unauthorized access. Cloud providers usually offer encryption options for data that is stored.



Access Control:

Create strong access control rules to limit who can use resources in the cloud. Use tools like Identity and Access Management (IAM) to manage user permissions. Use strong authentication methods, like multi-factor authentication (MFA), to improve security when accessing accounts.

Incident Response and Monitoring:

Set up tools to watch for any strange or suspicious actions in your cloud system. Create a plan to quickly handle any security problems if they happen.

Privacy Policies and Data Handling:

Review the privacy policies of cloud provider to understand how they handle data. Minimize the amount of personal or sensitive data stored in the cloud and only store what is necessary.

Network Security:

Use firewall rules, network segmentation, and Virtual Private Cloud (VPC) to secure your cloud resources. Keep an eye on network traffic and use tools to detect and respond to any suspicious activity.

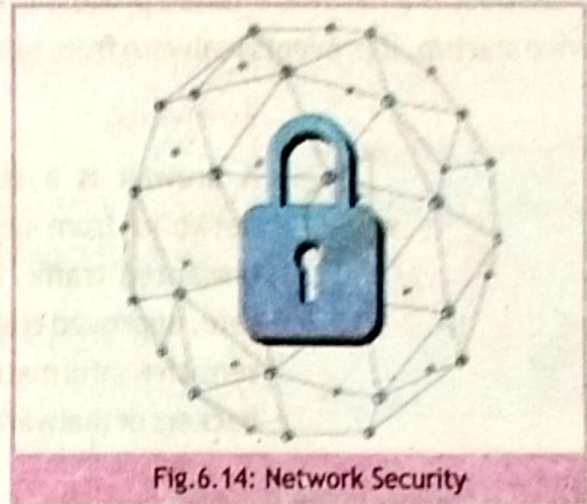

Fig.6.14: Network Security

6.5 Hardware and Software Method to Protect Devices

Using both hardware and software is really important to keep devices safe from different kinds of dangers. Hardware methods include things like using your fingerprint to unlock your device, or special technology to keep your information safe. It also means using special walls for your internet to stop bad things from getting in. Software methods are different; they involve installing programs on your device to stop viruses and other bad stuff. It also means updating your programs often to fix any problems and adding extra steps to make sure it is really you logging in. By using both hardware and software approaches, devices can stay safe from online dangers and people trying to get in without permission.

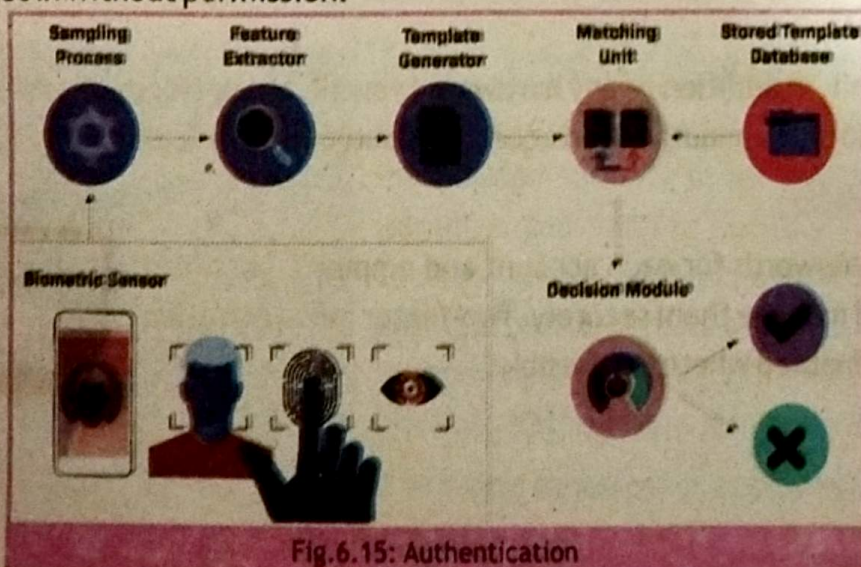

Fig.6.15: Authentication

6.5.1 Hardware Methods

Biometric Authentication:

Many modern devices come equipped with biometric sensors, such as fingerprint scanners or facial recognition cameras. These hardware components provide an extra layer of security by ensuring that only authorized users can access the device.



Secure Boot:

Secure boot is a hardware-based process that ensures only trusted software is loaded during the device startup. It prevents malware from infecting the boot process.

Firewalls:



A firewall is a security system that helps protect computers and networks from unauthorized access. It acts like a barrier, blocking unwanted traffic from entering or leaving a network while allowing safe, approved traffic to pass through. Firewalls help keep personal and sensitive information secure by filtering out potential threats, such as hackers or malware, before they can reach your device or network.

6.5.2 Software Methods

Antivirus and Antimalware Software:

Install reputable antivirus and antimalware software to regularly scan and protect the device from known threats. Keep these programs up to date to defend against new threats.



Operating System Updates:

Regularly update the operating system and software applications. Updates often include security areas that address weaknesses that hackers can exploit.

Firewalls (Software):

Use a software firewall, in addition to any hardware firewall, to control the traffic to and from the device. Configure it to block unauthorized access and outgoing data leaks.

Password Management:

Use strong, unique passwords for each account and employ a password manager to store and manage them securely. Two-factor authentication (2FA) should also be enabled wherever possible.



Virtual Private Network (VPN):

A VPN encrypts your internet connection, making it more difficult for cybercriminals to intercept your data. It also helps maintain anonymity and protects your online activities from curious eyes.

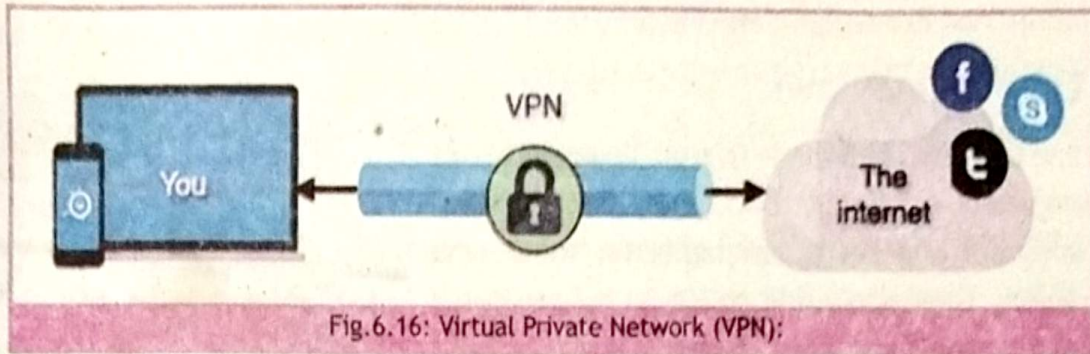

Fig.6.16: Virtual Private Network (VPN):

Data Backup:

Regularly back up your important data to an external device or cloud storage service. In the event of data loss due to malware or hardware failure, you can restore your information.

6.6 Cybersecurity

Cybersecurity refers to the practice of protecting computer systems, networks, and data from unauthorized access, cyberattacks, and other malicious activities. It involves implementing a range of technologies, processes, and practices to safeguard digital assets and ensure the confidentiality, integrity, and availability of information. Cybersecurity measures aim to defend against various threats, including malware, phishing scams, ransomware, and insider threats, among others. By implementing robust cybersecurity measures, individuals, organizations, and governments can mitigate risks, prevent data breaches, and preserve trust in the digital ecosystem.



Fig.6.17: Cybersecurity

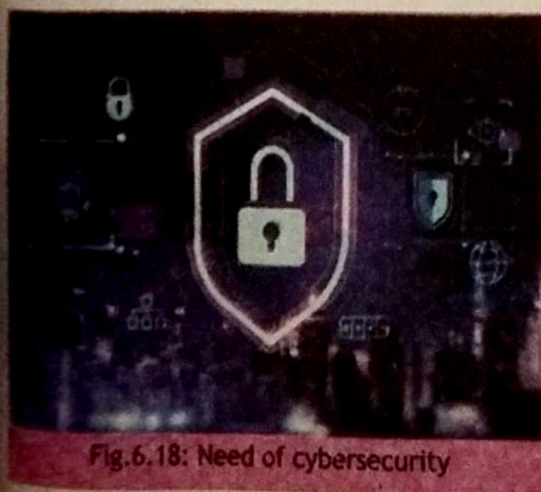

Fig.6.18: Need of cybersecurity

6.6.1 Need of cybersecurity

Cybersecurity is crucial for protecting privacy and information security in our digital era. As technology advances and systems become more interconnected, the amount of data exchanged online grows rapidly, posing significant challenges for privacy and security. Without strong cybersecurity measures, personal data like financial records and medical histories are at risk.

It is being accessed or exploited by malicious actors,

leading to identity theft and other serious consequences. Additionally, cybersecurity is closely linked to data security, which involves safeguarding information from unauthorized access or alteration. In conclusion, by prioritizing cybersecurity measures, we can protect sensitive data and maintain trust in our digital world.

6.6.2 Cybercrimes laws

Cybercrime laws are rules made to stop illegal activities using computers or digital tools. They explain what cybercrimes are and set punishments for those who commit them. They also guide police on how to catch and punish cybercriminals. Cybercrimes include hacking, identity theft, fraud, data breaches, cyberbullying, online harassment, stealing intellectual property, and cyber terrorism. Examples are breaking into computer systems, phishing scams, malware attacks on websites.



Fig.6.19: Cybercrimes laws

6.6.3 Instances of Cybercrimes

Cybercrimes involve various illegal activities done online. Examples include stealing personal information like social security or bank details to impersonate someone. Tricking people through emails or fake websites to get sensitive data is another example. Deploying harmful software like viruses to steal data or disrupt systems is also a cybercrime. Hacking into networks to steal important information is common. Running scams online to deceive and extort money is another form of cybercrime. Harassing or threatening others through social media is also included. Flooding websites with traffic to make them unusable is a type of attack. Stealing information or government secrets through espionage is another example. Misusing access to systems or data is also a cybercrime. Exploiting minors through online platforms is a serious cybercrime. These examples show the different types of cybercrimes that exist today.

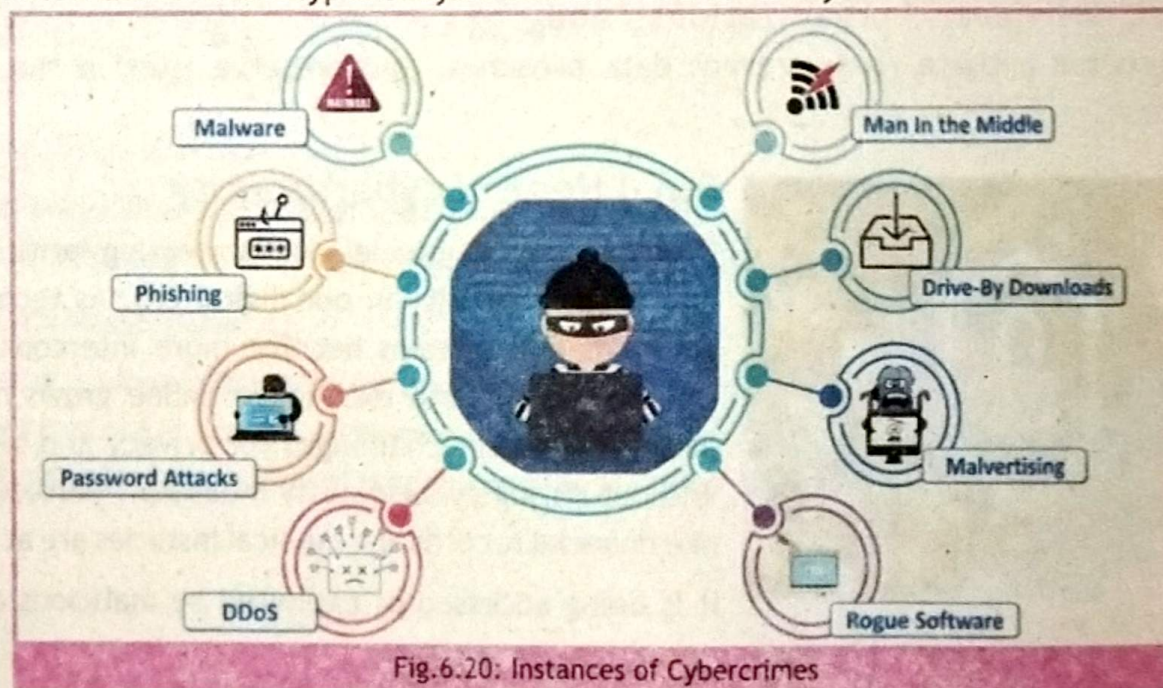

Fig.6.20: Instances of Cybercrimes

6.6.4 Common methods of reporting cybercrimes

Law Enforcement Agencies:

Reporting Cybercrime Contacting local police departments or national law enforcement agencies to report cybercrimes. Many countries have specialized cybercrime units or task forces dedicated to investigating and prosecuting cybercrimes.

Government Agencies:

Reporting cybercrimes to government agencies responsible for cybersecurity and digital crimes. These agencies often have dedicated hotlines, online reporting portals, or email addresses where individuals can report incidents and seek assistance.

Internet Service Providers (ISPs):

Informing ISPs about cybercrimes, especially if the incidents involve illegal activities conducted through their networks or services. ISPs may take action against malicious users or provide assistance in reporting incidents to relevant authorities.

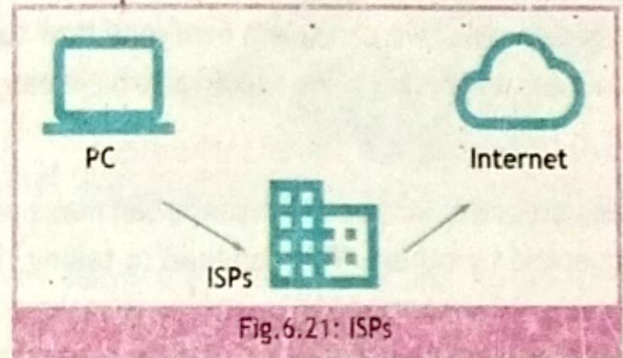

Fig.6.21: ISPs

Financial Institutions:

Notifying banks or financial institutions if cybercrimes involve unauthorized access to accounts, fraudulent transactions, or other financial crimes. Financial institutions often have procedures in place to investigate and address such incidents.

Online Reporting Portals:

Report cybercrimes using online portals set up by government agencies, law enforcement, or cybersecurity organizations. These platforms allow to report crimes anonymously or ask for help with cyber threats. By using these reporting methods, people and organizations help detect, investigate, and prosecute cybercrimes. This effort helps fight cyber threats and improve cybersecurity.

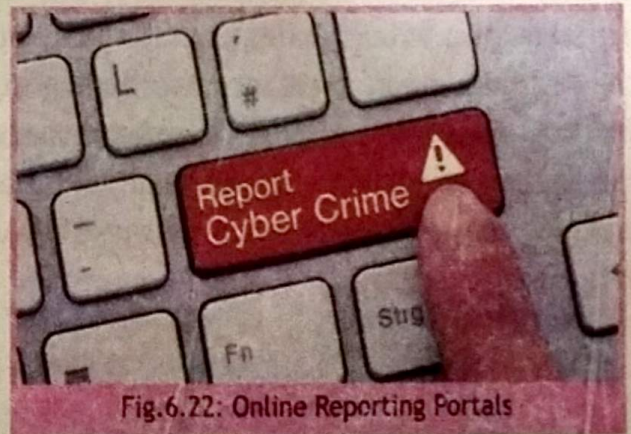

Fig.6.22: Online Reporting Portals

6.7 Safety and Security Concept

Safety and security on social media involve many challenges, such as protecting privacy, dealing with online harassment, cyberbullying, and peer pressure. To solve these problems, everyone needs to work together, including platform operators, policymakers, teachers, parents, and users. Promoting digital literacy and building supportive communities can make a difference. It is also important to put strong safety measures in place. By working together, we can create a safer and more positive online space for everyone.

Privacy Protection:

Social media platforms collect a lot of personal data, which raises privacy concerns. Users can protect their privacy by adjusting privacy settings. They should be cautious about sharing sensitive information. Regularly reviewing online profiles for publicly visible content is also important.

Online Harassment and Cyberbullying:

Online Harassment/Cyberbullying is when people use the internet to bully or scare others. This can really hurt the feelings and mental health of the victims. To stop cyberbullying, we can teach everyone how to behave nicely online. It's important to encourage kindness and respect. We should also have easy ways for people to report bullying and get help.



Fig.6.23: Privacy Protection

Peer Pressure and Social Influence:

Peer pressure and social influence can make people feel like they need to act a certain way to be accepted by others. This can lead to taking risks or making unhealthy choices. To stay safe and secure, it is important to learn how to make good decisions on your own. Building self-confidence helps you resist pressure. Creating supportive groups where everyone feels valued can also reduce the negative effects of peer pressure.

6.8 Cyberbullying

Cyberbullying is when someone uses the internet or digital devices to hurt, harass, or intimidate others. This can include mean messages, spreading rumors, or sharing private information to embarrass someone. It can happen on social media, through text messages, or in online games. Cyberbullying can make the victim feel very upset and unsafe.

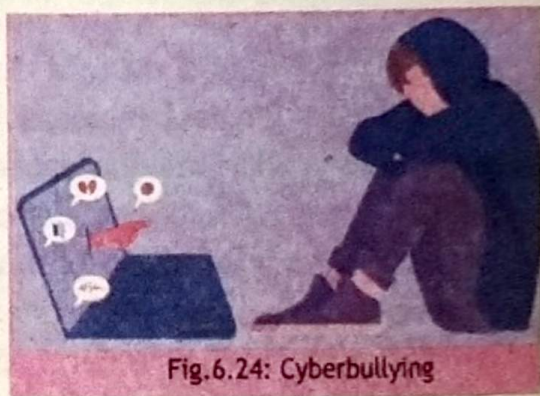

Fig.6.24: Cyberbullying

6.8.1 Impact of Cyberbullying/Harassment

Psychological Effects:

Victims often experience anxiety, depression, low self-esteem, and even suicidal thoughts. The constant fear and humiliation can have long-lasting psychological consequences.

Academic and Professional Impact:

Cyberbullying can make it hard for someone to focus on school or work, causing their performance to drop. It can also damage their professional reputation and future job opportunities.

Social Isolation:

Victims may stop joining social activities and feel alone. They might lose trust in others and find it hard to make new friends or relationships.

Physical Health:

The stress from online harassment can lead to physical health problems, such as headaches, sleep disturbances, and stomach issues.

Consequences of Cyberbullying:

Cyberbullying and harassment can have serious effects on a person. It can lead to stress, anxiety, and depression. Victims might struggle to focus on school or work, and their performance may suffer. They may feel alone, lose confidence, and have trouble trusting others or making new friends. In some cases, it can even harm their reputation and future job opportunities. Overall, it can deeply hurt both their mental health and social life.



Fig.6.25: Impact of Cyberbullying/Harassment

6.8.2 Strategies to Prevent Cyberbullying/Harassment

Education and Awareness:

Promote digital literacy and raise awareness about the consequences of cyberbullying among both children and adults. Teach responsible online behavior and empathy.

Parental Involvement:

Parents should be actively involved in their children's online activities. Setting rules and monitoring their internet usage.

School and Workplace Policies:

Schools and workplaces should have clear anti-cyberbullying policies in place. These policies should outline consequences for criminals and provide support for victims.

Reporting Mechanisms:

Establish anonymous reporting systems for victims and witnesses to report cyberbullying incidents. Ensure that reports are taken seriously and acted upon promptly.



Social Media Regulation:

Encourage social media platforms to implement stricter policies against cyberbullying and harassment. Platforms should swiftly remove harmful content and ban repeat lawbreakers.

6.9 The Environmental, Cultural and Human Impact of Computing and Assistive Technologies

Computing and assistive technologies affect the environment, culture, and people in many ways. They can improve lives by making tasks easier, especially for those with disabilities. However, producing and using these technologies can impact the environment due to energy use and electronic waste. They also influence cultures by changing how we communicate, learn, and work.

6.9.1 Environmental Impact

The environmental impact of computing and assistive technologies includes high energy use and electronic waste. Devices like computers and data centers need a lot of electricity, which can lead to pollution and greenhouse gas emissions. As technology advances, devices are often quickly replaced, creating electronic waste (e-waste) with harmful materials that can harm the environment if not safely recycled. Efforts are being made to reduce these impacts, but challenges remain.

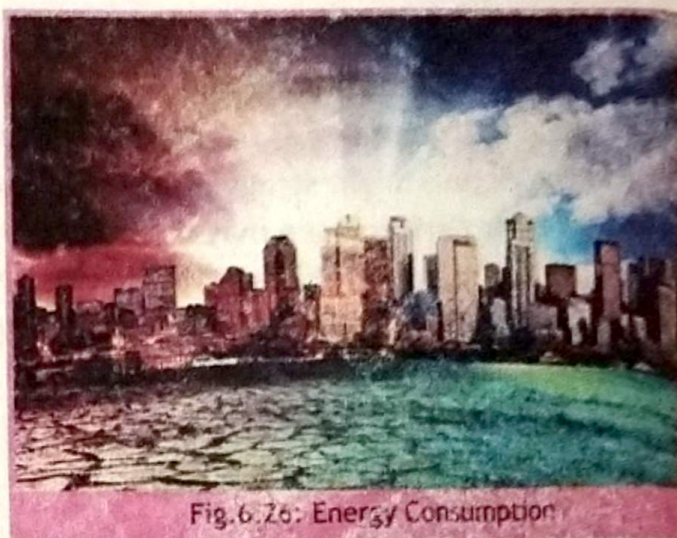

Fig. 6.26: Energy Consumption

6.9.2 Cultural Impact

The cultural impact of computing and assistive technologies is seen in how they change the way people interact, learn, and work. These technologies make it easier to connect across distances, share information, and access educational resources. They also help people with disabilities participate more fully in society. However, they can also lead to less face-to-face communication and may create a digital divide. This gap can make cultural and economic differences.

6.9.3 Human Impact

The human impact of computing and assistive technologies is both positive and challenging. These technologies make tasks easier, especially for people with disabilities, helping them to communicate, learn, and work better. However, using technology too much can cause problems like addiction, stress, and less physical activity. Also, technology is always changing, which can lead to job changes and challenges in learning new tools.

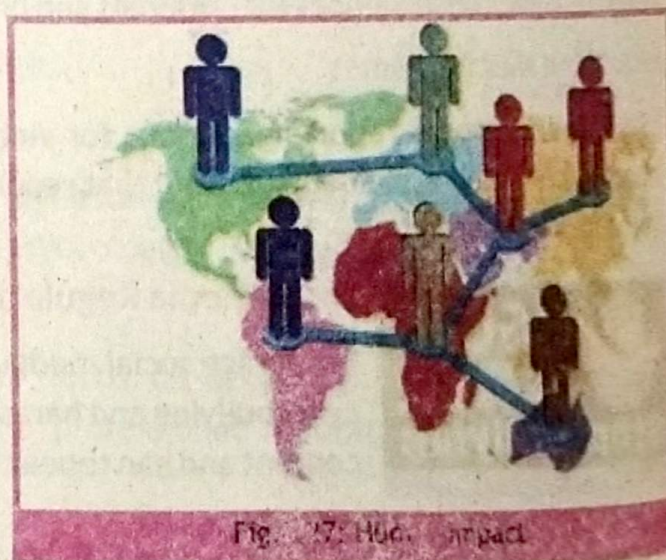

Fig. 6.27: Human Impact

6.10 Digital Divide

The digital divide means some people or groups have less access to technology, like the internet, compared to others. This gap can show up in different ways and affect individuals, groups, or even whole areas. It is a big deal because it can cause problems in society, the economy, and politics.

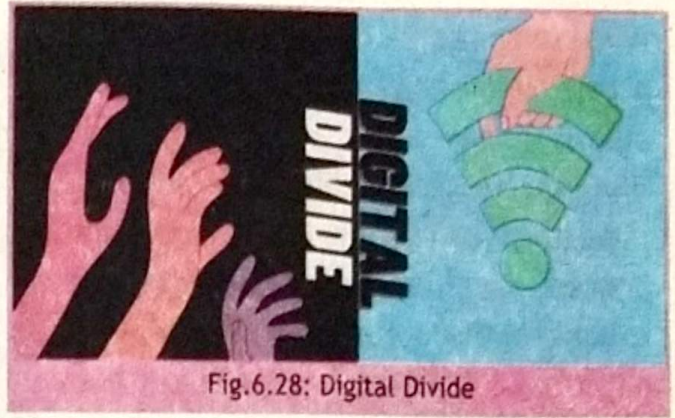

Fig.6.28: Digital Divide

Analyze the impacts of the digital divide on access to critical information:

The digital divide limits access to critical information, especially for those without reliable internet, devices, or digital skills. People in low-income, rural, or underserved areas often miss out on essential services like online education, healthcare, and job opportunities. This divide worsens social inequalities, leaving some groups without important resources or timely information. Bridging the digital divide can improve equity, giving everyone a fair chance to connect, learn, and grow.

6.10.1 Access Divide

Infrastructure:

One aspect of the digital divide is access to the physical infrastructure. The infrastructure required for digital connectivity, including broadband internet, computers, and mobile devices. Rural or remote areas often have limited or no access to high-speed internet, creating an urban-rural divide.

Affordability:

Even when infrastructure is available, cost can be a barrier. Internet service, computers, and smartphones can be expensive for low-income individuals and families, making them inaccessible.

6.10.2 Usage Divide

Digital Literacy:

Just having access to technology is not enough. People also need to know how to use it well. Some, especially older people, might not have the skills to use digital tools and the internet properly.

Relevance of Content:

Some people can use the internet, but they might not see it as important for their everyday life. This could be because there is not much content available in their language or about things that matter to them.



6.11 Inequitable Access to Information

When some people do not have the same access to information or technologies as others, it can really affect their lives. Imagine if you could not find out important things or learn new stuff because you did not have the same access to books or the internet as other people. It might make it harder to do well in school or find a good job. Having fair access to information is really important for everyone to have the same opportunities.



Fig. 6.29: Inequitable Access to information

Case Study

Apply Safe & Responsible Use of the Internet

Scenario:

Ali, a Grade 10 student, loves using the internet for studying, gaming, and socializing with friends. However, he recently noticed that he spends too much time online, which affects his studies and sleep. Additionally, he sometimes receives strange friend requests and messages from unknown people on social media, which makes him feel uncomfortable. He is also unsure if the websites he visits are safe and if his personal information is secure.

Ali's school has introduced a session on responsible internet use, focusing on the importance of balancing online activities, recognizing safe websites, and protecting personal information.

Objective:

To help Ali and his classmates "apply safe & responsible use of the internet to prevent addiction, promote information and data security." Demonstrates how students can apply safe and responsible internet practices to balance their online activities, avoid addiction, and ensure information and data security.

Unit Summary

- ▶ **Internet Safety:** The practice of using the internet in a secure and responsible manner to protect personal information and avoid online threats.
- ▶ **Internet Addiction:** Compulsive and excessive use of the internet that interferes with daily life, relationships, and well-being.
- ▶ **Cyberbullying:** Online harassment or bullying that can cause emotional distress and has significant negative impacts on individuals.
- ▶ **Technology Addiction:** Compulsive and excessive use of digital devices and platforms, leading to negative effects on mental health, productivity, and relationships.
- ▶ **Internet:** A global network of interconnected computers and devices that allows for the sharing of information and communication.
- ▶ **Spam:** Unwanted and often malicious emails that compromise user privacy and security.
- ▶ **Spyware:** Malicious software that secretly monitors and collects personal information from users.
- ▶ **Cookies:** Small text files stored on a user's device to track online activity, which can raise privacy concerns.
- ▶ **Cloud Computing:** Technology that provides access to computing resources and services over the internet, allowing for scalable and flexible use of IT infrastructure.
- ▶ **Public Cloud:** Cloud computing services offered over the internet by third-party providers to multiple users.
- ▶ **Private Cloud:** A cloud computing environment exclusively used by a single organization, offering more control over data and security.
- ▶ **Data Encryption:** The process of converting data into a coded format to prevent unauthorized access.
- ▶ **Access Control:** Policies and mechanisms that restrict access to resources based on user roles and permissions.
- ▶ **Network Security:** Measures taken to protect data during transmission over networks, including firewalls and intrusion detection systems.
- ▶ **Biometric Authentication:** Security measures that use biological characteristics, such as fingerprints or facial recognition, to verify identity.
- ▶ **Secure Boot:** A hardware-based process ensuring only trusted software is loaded during startup, protecting against malware.
- ▶ **Antivirus Software:** Programs designed to detect, prevent, and remove malware from devices.

- **VPN (Virtual Private Network):** A service that encrypts internet connections, enhancing privacy and security.
- **Data Backup:** The practice of regularly saving copies of important data to prevent loss due to cyber threats or hardware failures.
- **Cybersecurity:** The practice of protecting computer systems, networks, and data from unauthorized access, cyberattacks, and other malicious activities.
- **Cybercrime Laws:** Rules designed to prevent illegal activities using computers or digital tools, defining cybercrimes and setting punishments for offenders.
- **Digital Divide:** The gap between individuals or communities with access to digital technologies and those without, affecting societal, economic, and political opportunities.
- **Access Divide:** The disparity in access to physical infrastructure and affordability of digital technologies between urban and rural areas and among different income groups.
- **Usage Divide:** The gap in digital literacy and relevance of content, impacting individuals' ability to effectively use technology.
- **Participation Divide:** The disparity in engagement in online activities, economic opportunities, and access to online services due to lack of technology or skills.
- **Global Divide:** The worldwide disparity in access to technology and digital resources between richer and poorer countries.

Exercise

Select the best answer for the following Multiple-Choice Questions (MCQs).

1. _____ is a key reason for being careful and responsible online?
- a) To save money
 - b) To avoid technology addiction and protect personal information
 - c) To become more popular
 - d) To learn new skills
2. Spending too much time online be harmful for?
- a) Mental health and productivity
 - b) Physical fitness and diet
 - c) Shopping habits
 - d) Travel plans
3. Which of the following is NOT a way to protect personal information online?
- a) Using strong passwords
 - b) Being alert for scams
 - c) Sharing your passwords with friends
 - d) Keeping privacy settings updated
4. Technology addiction is well described by
- a) Using technology occasionally
 - b) Excessive use of digital devices
 - c) Avoiding all forms of technology
 - d) Only using technology for work purposes
5. What is a common result of excessive screen time?
- a) Enhanced social skills
 - b) Social isolation and loneliness
 - c) Improved academic performance
 - d) Increased physical activity
6. Which of the following is a way to reduce technology addiction?
- a) Increasing online gaming hours
 - b) Practicing mindful use of technology
 - c) Ignoring signs of addiction
 - d) Sharing personal information online
7. Select one benefit of using the internet for good purposes?
- a) Increasing online fraud
 - b) Access to educational resources
 - c) Spreading misinformation
 - d) Cyberbullying
8. _____ of the following is a positive use of the internet?
- a) Cybercrime
 - b) Online harassment
 - c) Supporting social meeting
 - d) Distributing illegal content
9. _____ is a way to protect your device from online threats?
- a) Avoid using antivirus software
 - b) Ignore software updates
 - c) Use biometric authentication
 - d) Share passwords freely

10. Which method is a hardware method to protect devices?

- a) Biometric authentication
- b) Secure boot
- c) Firewalls
- d) All

11. What is a public cloud?

- a) A cloud environment used by one organization
- b) A cloud service offered to the general public by a third-party provider
- c) A private network for personal use
- d) A secure boot process for devices

12. ____ is the primary goal of cybersecurity?

- a) To increase internet speed
- b) To protect computer systems and networks
- c) To develop new software applications
- d) To create more social media platforms

13. Which of the following is an example of a legal online activity?

- a) Hacking into a network to steal information
- b) Tricking people through phishing scams
- c) Developing a new mobile app
- d) Deploying malware to disrupt systems

14. Why is cybersecurity essential in the digital era?

- a) It helps in faster data transmission
- b) It reduces the need for technical support
- c) It decreases the cost of internet services
- d) It ensures that personal data is protected. from malicious actors

15. Role of students which can minimizing the digital divide?

- a) Developing new gaming applications
- b) Providing technology training and support to those who need it
- c) Reducing the prices of digital devices
- d) Creating more social media accounts

Give short answers to the following Short Response Questions (SRQs).

1. List the importance of safely use of internet today?
2. State four ways to protect personal information online?
3. Mention three benefits of cloud computing?
4. Why is cybersecurity essential in today's digital era?
5. Name three common types of cybercrimes.
6. What would you do if your friend faced cyberbullying?

Give long answers to the following Extended Response Questions (ERQs).

1. What are the impacts of cyberbullying and online harassment, and what strategies can be implemented to prevent them?
2. Describe the various threats that cybersecurity measures aim to defend against.
3. Explain the role of cybercrime laws in addressing illegal activities conducted through digital tools.
4. Analyze the cultural impact of computing technologies. How do these technologies facilitate global connectivity and cultural exchange.
5. Examine the effects of the digital divide on access to information. How does this divide affect education, employment, healthcare?



Activity-1

Safe and Responsible Use of the Internet

Grade 10 students will learn about safe internet use to prevent addiction and enhance data security. Over two class periods, students will discuss internet safety, research related topics, and present their findings. They will create posters promoting responsible internet use and participate in a gallery walk to view and comment on their peers' work. Assessment includes participation, presentations, and creative posters. A reflection homework assignment will reinforce the principles learned.



Activity-2

Preventing Cyberbullying and Harassment

Grade 10 students will evaluate the impact of cyberbullying and learn strategies to prevent it. In groups, they will research the effects of cyberbullying and present their findings. Each group will create an anti-cyberbullying campaign poster. The class will discuss effective prevention strategies and display their posters around the school to raise awareness.



Teacher Points:

"Evaluate the impact of and apply strategies to prevent cyberbullying/harassment"

1. Understanding Cyberbullying

- Define cyberbullying and explain how it can occur on various online platforms (social media, messaging apps, games, etc.).
- Discuss the forms it can take, such as harassment, spreading rumors, impersonation, and exclusion.

2. Evaluating the Impact

- Explain the effects of cyberbullying on victims, including emotional stress, anxiety, depression, and academic struggles.
- Share real-life examples or case studies to illustrate the seriousness of these impacts.

3. Recognizing Signs of Cyberbullying

- Teach students how to recognize if they or others are being cyberbullied (e.g., feeling scared to check messages, changes in mood or behavior).

4. Strategies to Prevent Cyberbullying

- Encourage respectful communication and responsible online behavior.
- Teach students how to adjust privacy settings, block/report users, and avoid engaging with negative comments.
- Discuss the importance of supporting peers who may be victims of cyberbullying.



Learning Outcomes

At the end of this unit students will be able to:

- communicate and publish key ideas and details to a variety of audiences using appropriate digital tools and media-rich resources.

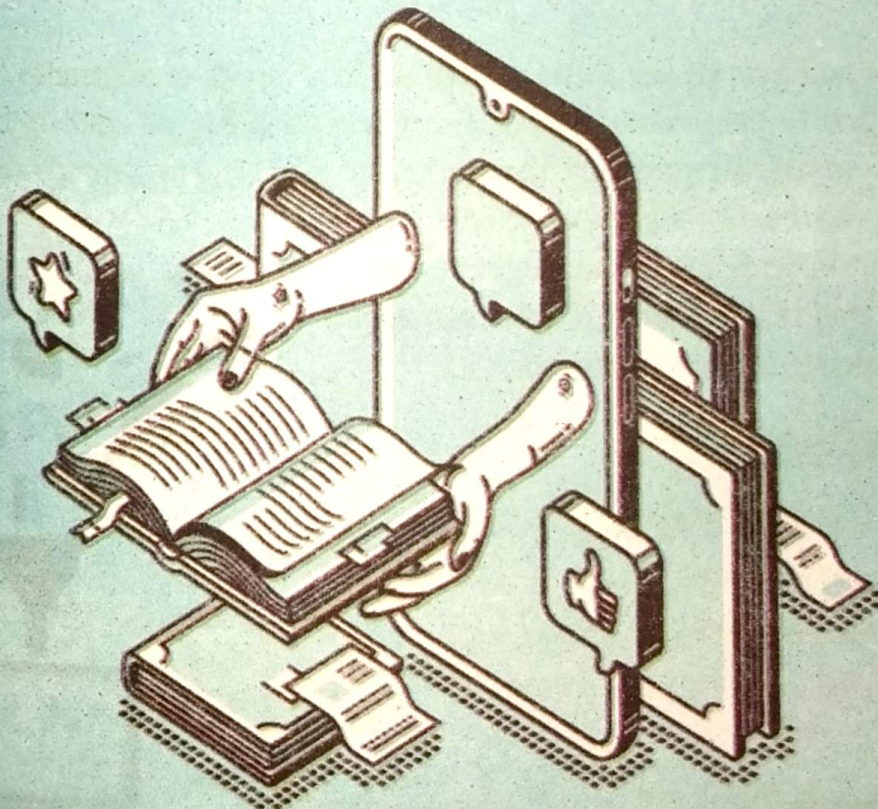

Introduction

Literacy is the term used for the ability to read, write and communicate information effectively. In today's life, digital literacy is as important as basic literacy. Digital literacy is the ability to create information in a digital environment. It refers to the ability to effectively use digital technologies to access information. This information can be converted into meaningful and appealing way after careful evaluation.

Now a days, data is available everywhere. When we send a text message, create a bank account, register for a course in some college or university, book a ticket for movie, make an appointment to the cardiologist, apply for the visa to travel, we are creating data form.

It is nearly impossible to be digitally illiterate. Digital literacy enables us to access, navigate, evaluate and create information in an effective way. There are several methods in which digital literacy is playing an important role in our daily lives. For example, if we want to search for some good restaurants around, the easiest and simplest choice is to explore via cellphone. We will search through some search engine, or we will check from some food service providers applications.

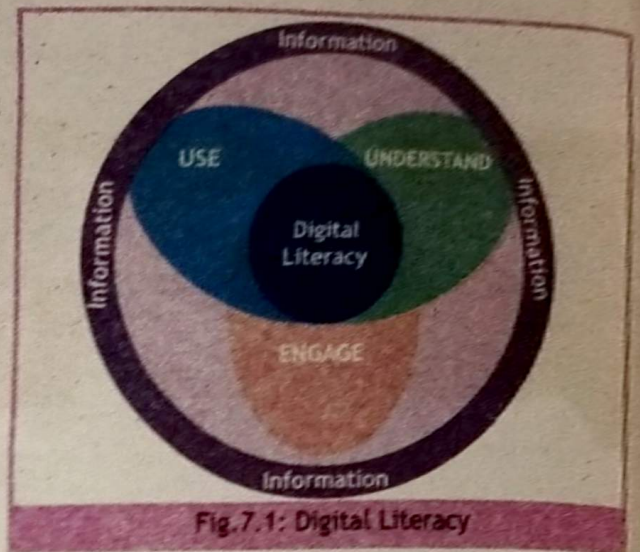

Fig.7.1: Digital Literacy

7.1 Information Collection

To communicate and publish key ideas and details to a variety of audiences, first we need to collect information to be communicated. This information can be collected through various sources. In other words, we must have some information in hand to communicate it. The role of digital literacy is how beautifully and effectively we can communicate this information to our target audience. We will see the traditional sources of information and types of information to be communicated.



DO YOU KNOW?

Facebook: was introduced on February 4, 2004.

YouTube: was introduced in 2005.

Twitter: was introduced on March 21, 2006.

Instagram: was introduced on October 6, 2010.

In the current time as the world has become a global village, the sources of information seem to be unlimited. However, here we will discuss some common



Fig.7.2: Information Collection

sources of information as follows:

Books: Despite all the modern advancements in science and technology, books are still thought to be the most reliable and authentic source of information. Even in some fields of life, books are considered to be more reliable as compared to the internet and other web sources e.g. religion and history etc. Therefore, books are the most reliable, common and authentic source of information to be communicated to the target audience. Whenever you are supposed to communicate with a huge audience, create any digital content or find some information, you can collect information from books related to that topic. For example, you have an assignment to prepare a presentation on the topic of (اردو ادب میں خواتین کا کردار) (Role of Women in Urdu Literature).

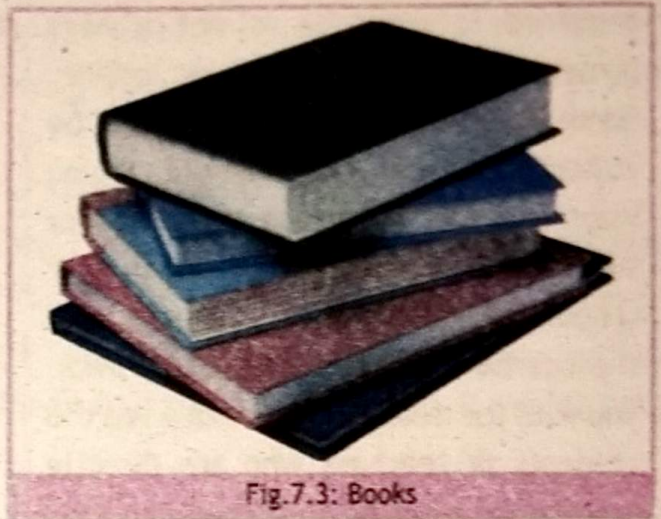

Fig.7.3: Books

To prepare the presentation you will find the Urdu literature books from your school library. These books can be written about the women or by the women, who had prominent role in Urdu Literature. After collecting relevant data, you will organize them in the form of digital presentation by using some tools like MS-PowerPoint, Canva or any other software of your choice.



DO YOU KNOW?

First Animation: The first viral video on the internet was the "Dancing Baby" animation, released in 1996.

Digital Native: This term was used in 2001 to describe people who grew up with the internet.

Web Sources: The internet is the most common source of information now a days. Suppose you want to find some entertainment point for a person of any age or want to find or confirm some information, the internet is the most commonly available source.

Let's suppose you want to find information on some latest international scholarships for the subject of computer science. The web sources from international universities will be more reliable as compared to local websites. To find this information type the search string "International undergraduate scholarships for Pakistani Students" on the Google home page. You will get many results.

Explore the suggested results and open the webpages displayed as a search result. In the same way you can find information on various topics, from the Internet.



Fig.7.4: Web Sources

Surveys and Google Forms: All the required information is not always present in books or available online. Some information is supposed to be collected by you. For example, if you want to know about the popularity or success of a new course offered in your school, you cannot get information from the internet. The right people to provide you with the desired information are the students or teachers who are directly learning or teaching that course in your school. You can conduct a survey to collect that information. There are various methods to conduct a survey e.g.:

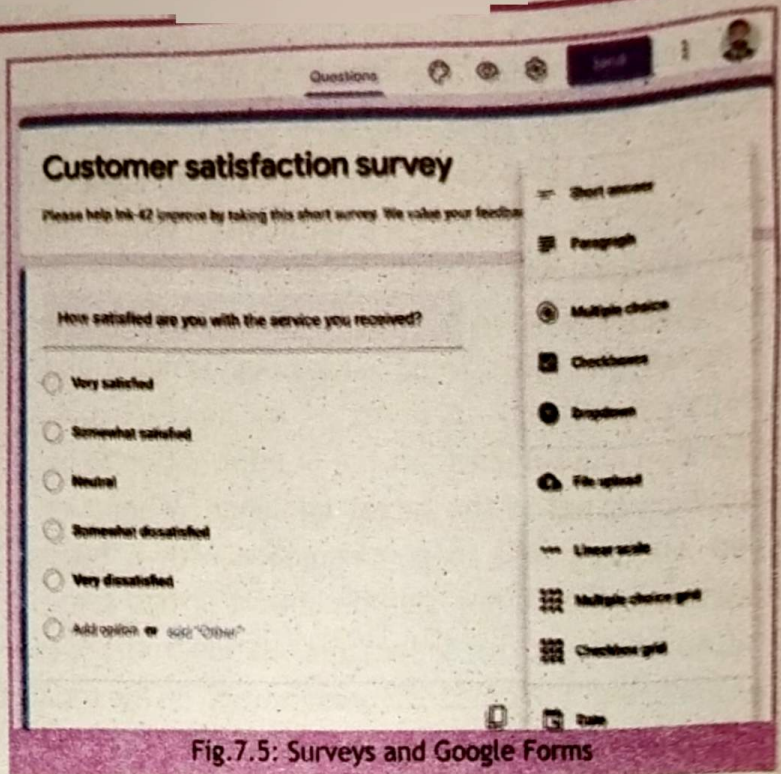

Fig.7.5: Surveys and Google Forms

- Design a google form and distribute it online to collect information.
- Design a form in some document editor and distribute its printout to collect the information

There are some key differences between survey and Google form.

Survey is used for:

- Research purposes
- Data collection on a large scale
- Statistical analysis
- Data analysis

Google form is used for:

- Data collection on small scale
- Event registration
- Feedback collection
- Quick polls and quizzes

7.1.1 Components of Digital Literacy

There are certain components which play an important role in digital literacy. Some of them are as follows:

Digital Search/Information Literacy: It is the ability to collect, understand and evaluate information from various sources. This unit emphasizes this component of digital literacy. Other components will be discussed in detail in advance grades.

Digital literacy begins with knowing how to find information online. You can find information by using search engines like Google, Bing, yahoo etc. or websites to look for relevant information. Various companies provide their personalized applications to provide services and information like if you want to check for any popular Bus service from Islamabad to Karachi, you can install their dedicated app and check their schedule. You can also make your reservations and even buy online tickets with the help of digital payment methods like Easypaisa, Jazzcash, Upay etc.

- Example: If you want to find out how to solve a math problem, you can use Google to search for tutorials or watch a YouTube video explaining the steps.

Technical Skills: The technical knowledge and skill to use digital devices is required to communicate the information in digital form. The ability to use smartphone, digital cameras, computers, microphone and related devices is needed for digital literacy. Technical skills can be listed as follows:

- The ability to use computer and smartphones.
- The skill to navigate on internet and find relevant information while keeping your personal information and devices safe from cyberattacks.
- The ability to find and install relevant software and mobile applications to perform specific tasks. e.g. to install zoom, WhatsApp, or MS Teams to communicate with personal or official contacts to share digital information.
- Advanced skills include use of word processing and presentation software to develop digital content. To create vlogs, webpages, digital images and videos for social media marketing or interaction to communicate digital information.

Communication: The objective of digital literacy is to communicate the collected information to the target audience effectively. Good communication skills clearly express thoughts and opinions. It also includes appropriate online behavior, etiquette, netiquette and other digital communication protocols. Good digital communication skills include:

- Preparation of digital contents like images, videos
- Preparation of word processing documents
- Designing good PowerPoint presentations
- Sending and receiving emails
- Creating google forms, and google sheets for data collection

All these digital content helps to communicate digital information by using digital devices like computer, smartphones etc.

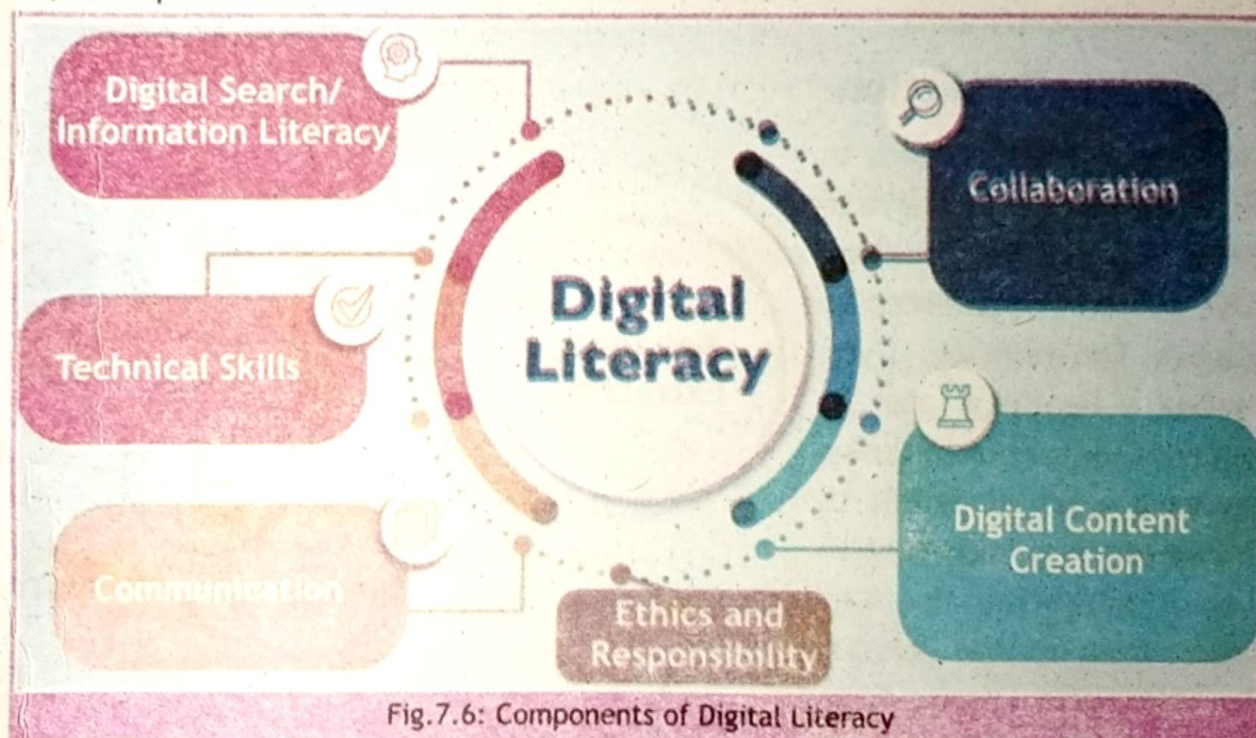

Fig.7.6: Components of Digital Literacy

Collaboration: The use of digital devices involves networking and collaboration with other people across distances. Online meetings, documents sharing, shared projects and activities are part of digital literacy. To develop digital citizenship and responsibility for correct information is also required in a healthy collaborative environment. Collaboration includes:

- Sending messages by using digital devices e.g. WhatsApp, Zoom, Google Chat etc.
- Editing and sharing google docs, sheets, slides and other real time collaboration platforms like LinkedIn, GitHub, Facebook, YouTube etc.

Digital Content Creation: The final product of the entire process is the digital content created for the audience. This content can be in the form of a graphical poster, Facebook post, YouTube video or some research paper. The other form of digital contents can be presentations, videos, interactive stories, online tutorials, webinars, audiobooks, blog posts, infographics, animations, quizzes, simulations, and games etc.

Ethics and Responsibility: The digital content has no boundaries. Therefore, higher standards of ethics and responsibility are required. These ethical standards involve cultural, social, and religious boundaries. Some important aspects of ethics are as follows:

- Ethical standards must respect cultural differences, as people from various backgrounds may interpret content differently.
- Cultural norms should be respected in digital content, ensuring that traditions, customs, and practices from different cultures are acknowledged and not misrepresented or disrespected.
- Social norms and values also vary, so content should be shared responsibly, ensuring it does not harm or offend different communities.
- Religious beliefs should be considered when sharing digital content to avoid disrespecting or infringing on the values of diverse faiths.

Overall, creators and users of digital content should be mindful of the global audience and act with responsibility and respect.

7.1.2 Key Ideas Extraction

When you are given some data to display it in digital form you have to analyze it. All the information cannot be posted or presented to the audience. For example, if you are creating a Facebook post to invite your friends to your birthday, you may have a lot of details to share. However, it is important to focus on highlighting the key information from all the details. This key information varies from

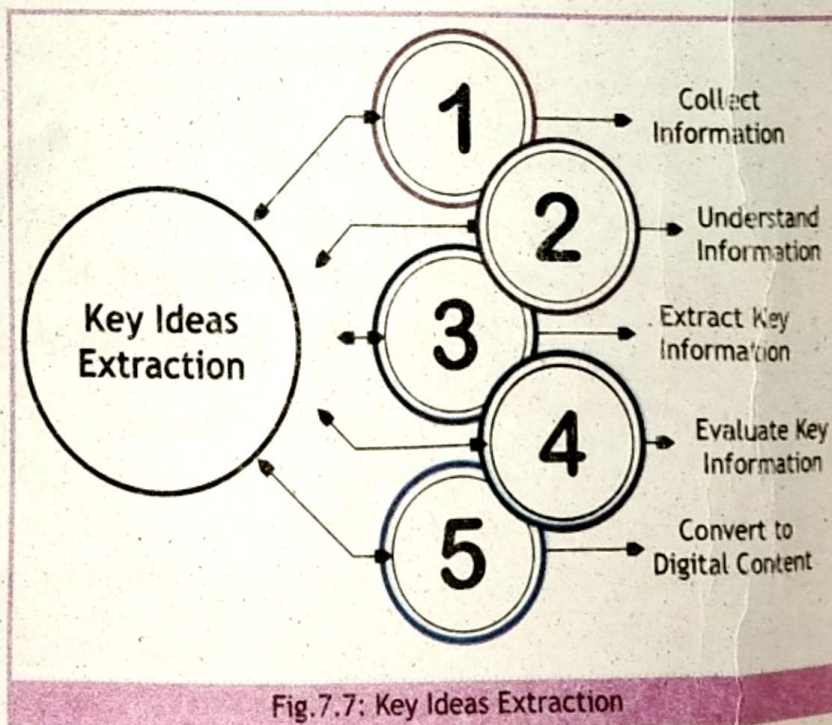

Fig.7.7: Key Ideas Extraction

data to data. In this example of a birthday party, the most important or key information is the date, time and venue of the party. Other minor details might include some theme or costumes or weather conditions etc. To extract key information from the data following are some guidelines:

1. Collect Information

- ▶ Begin by gathering relevant information from various sources such as books, articles, websites, and videos.
- ▶ Ensure diversity in your sources to gain a well-rounded understanding of the topic.
- ▶ To extract key information from the data, read it carefully to ensure a thorough understanding.

2. Understand Information

- ▶ Carefully read the collected data to fully comprehend the content.
- ▶ After reading the material, critically analyze it to identify any incorrect information or gaps that need addressing.
- ▶ Look for any missing information that is necessary for clarity.

3. Extract Key Information

- ▶ Focus on identifying the main points that are most relevant to your purpose.
- ▶ Determine the objective of sharing this information.
- ▶ Consider your audience's perspective: what important insights or results will they gain from the information shared digitally?

4. Evaluate Key Information

- ▶ Assess the relevance and reliability of the extracted key points.
- ▶ Ensure the information is accurate and effectively represents the core ideas.

5. Convert to Digital Content

- ▶ Summarize the key ideas in a clear and concise manner.
- ▶ Use graphical representations, such as charts or infographics, to make the content visually appealing.
- ▶ To convert the information or idea into graphics, decide on an appropriate tool for designing.
- ▶ Traditionally, information has been presented using charts and diagrams to convey messages effectively. However, in the digital realm, there are endless options available.
- ▶ For example, you can create a presentation in MS PowerPoint or design a poster in MS Paint.
- ▶ Visualize your design with creativity and critical thinking before starting with any tool.
- ▶ Be prepared to adjust your design due to the limitations of the graphics tool but ensure that the key information remains intact.
- ▶ Any changes in design should not affect the effectiveness and meaningfulness of the graphics design.

➤ This approach enhances engagement and helps convey information more effectively.

7.1.3 Ideas Presentation by Graphics

To convert the information/idea into graphics, the first step is to decide an appropriate tool for designing. Traditionally the information has been presented by charts and diagrams to convey the message. To convey the message in digital format, there are endless options. As discussed earlier there are five general steps shown in the figure: Collect Information, Evaluate, Visualize, Create Design and Present the information. The first two steps are already discussed in this unit. Here we will discuss the last three steps:

Visualize

Before selecting a design tool, visualize your graphic concept creatively. Consider how the information can be represented through traditional means, like charts and diagrams, as well as through modern digital formats like digital image, presentation, or video.

Create Design

Once you have a clear visualization, choose an appropriate tool for creating your design. Whether you opt for MS PowerPoint or MS Paint, ensure that your chosen method allows you to effectively convey your message while keeping the key information intact.

Present

Finally, present your design in a way that captures your audience's attention. Be prepared to adjust your design if necessary due to tool limitations. However, it is important that any changes should not compromise the effectiveness or meaningfulness of your graphics. This thoughtful approach will enhance your digital literacy skills by effectively communicating your ideas through visual means.

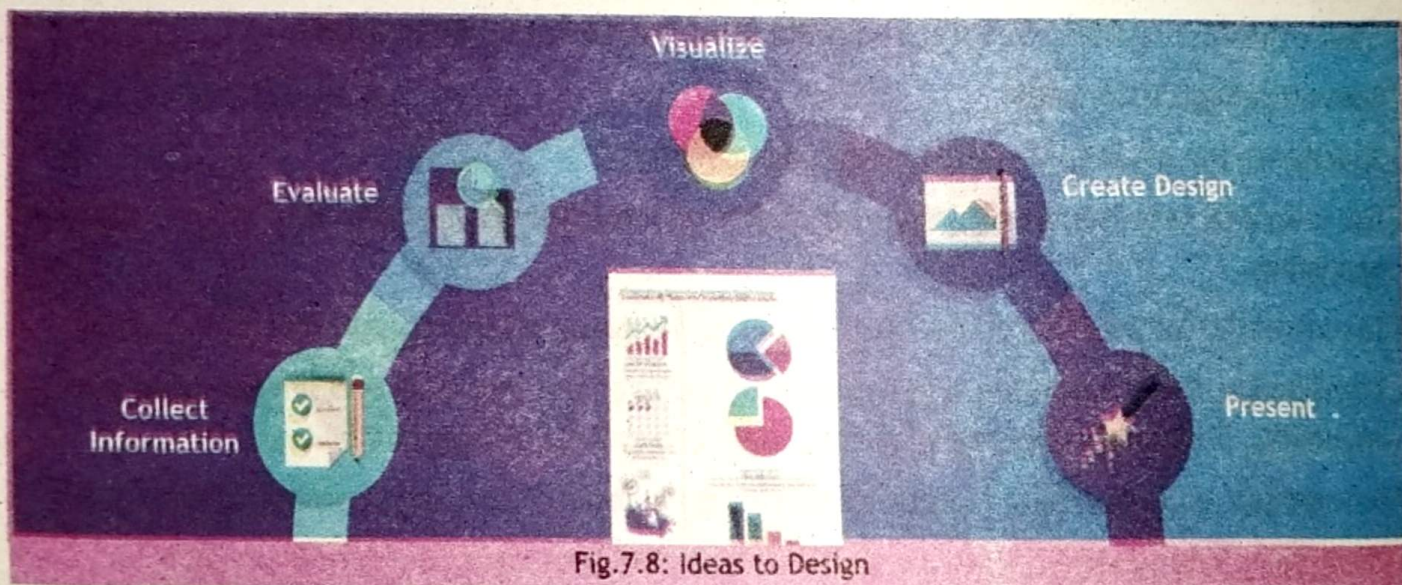

Fig.7.8: Ideas to Design

7.1.4 Poster Designing

To design an effective poster, certain principles should be kept in mind. First the poster should present the clear purpose of its creation. It should give the message for which it is designed. It should be simple and concise as well as attractive to capture the attention of the audience. It

should be visually appealing. The color scheme should be according to its topic/genre. For example, if a poster is designed to announce some social gatherings, it should give pleasing and lively feelings. Most of the time the response of the audience depends on the visual appeal of the digital content. The text and graphics should have some balance and alignment in size, colors, and other aspects.

Different design elements, like shapes, text, graphics should have harmony. They should not give scattered or disconnected feelings with respect to various elements. It should be legible and convey the correct information for which it has been designed. There are several software available to design digital graphics contents, like Adobe Photoshop, Adobe Illustrator, Corel Draw and Canva etc.

7.1.5 Billboard Designing

Like a digital poster, simplicity is a key step in billboard designing as well. The billboards are huge in size and made to attract the audience on the go. Therefore, an attractive billboard design will attract the audience otherwise it might be ignored and does not serve its purpose.

Billboard should contain the logo and other brand recognition elements. The key message should be highlighted, and other picture elements should not overshadow the key message. The demographics and interests of the target audience are important to consider. For example, in any billboard design the cultural values should be taken care of, otherwise it might become ineffective as well as have a bad impact on the company's name. The key message, objective, graphical elements, and color scheme should be in coordination.

Regarding billboard designing there might be certain rules and laws of the local authorities. Those limitations should be considered in advance.

7.1.6 Social Media as a Communication Tool

Now a days social media is an inevitable part of daily life. There is hardly any individual who is not using social media regularly. The most common usage of social media is audio and video calls and other necessary communication. Currently, social media is one of the most effective tools of



communication. Different people are using social media for different purposes. For example, businesses are using it to reach their potential customers. The customers are using social media to find their favorite products, without leaving the comfort of their home, or without disturbing their work routine.

We can use social media as a communication tool with ease, but there are certain limitations. As social media is not directly controlled by any country or local laws, it may communicate wrong information. Disinformation and misinformation are the most common characteristics of social media. Therefore, while conveying your message via social media you should share authentic, and undoubted contents.

Here we will discuss some commonly used social media platforms.

YouTube

It is a social media platform commonly used for reels and video sharing. It is also used for live streaming. This platform is open for all the users across the world. People or users can upload their personal or professional video content. You can communicate your message across the world, by using this platform. Similarly, you can watch content shared by other users as well. This platform is effectively used for learning and entertainment purposes. To upload your video content on YouTube, you are supposed to create a channel. After creating your channel on YouTube, you can upload your video content on it. It is used for marketing purposes as well. The following are the steps to create a YouTube Channel:



DO YOU KNOW?

Disinformation: It refers to a deliberate false or misleading information designed/spread to mislead and manipulate the people.

Misinformation: It refers to an honest mistake spread by someone in ignorance. There is no hidden objective behind this wrong information.

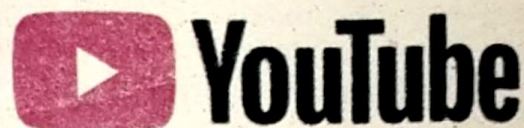

1. Open YouTube Studio by downloading the app from the Google Play Store (Android), App Store (iOS), or visiting www.youtube.com on your browser (Chrome, Safari, Firefox etc.).
2. Click on the Sign In option.
3. YouTube is a digital tool/platform provided by Google, you need to give your Gmail id and password to login. Type your existing Gmail id and password. Or you can create an ID if you don't have it.
4. Set your profile picture by clicking on the profile picture option or you can skip this step by clicking "Not Now" option.
5. On the top right corner of the browser click on your profile and click on "Create Channel" option.
6. Give the name of your channel and handle and click on "Create Channel" option. Note you can change the name of your channel at any time, the channel handle is the string which you can directly type in the browser address to see the public contents uploaded on your channel.

7. On the next screen you will see the message, “Your channel is being created. Check back in a few moments.”

8. Now on the Channel Dashboard you can see the analytics of your channel. You can upload various video contents, shorts, reels etc.

Note: The interfaces of all web platforms keep on changing and updating from time to time and from device to device. A sequence of steps is shown graphically in the following figures 1 through 6.

1

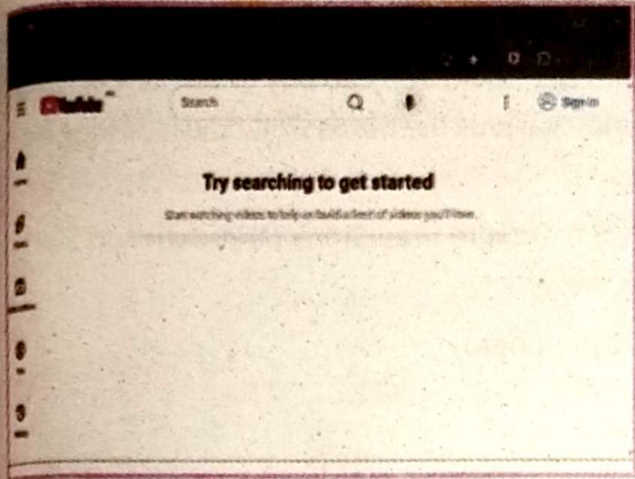

2

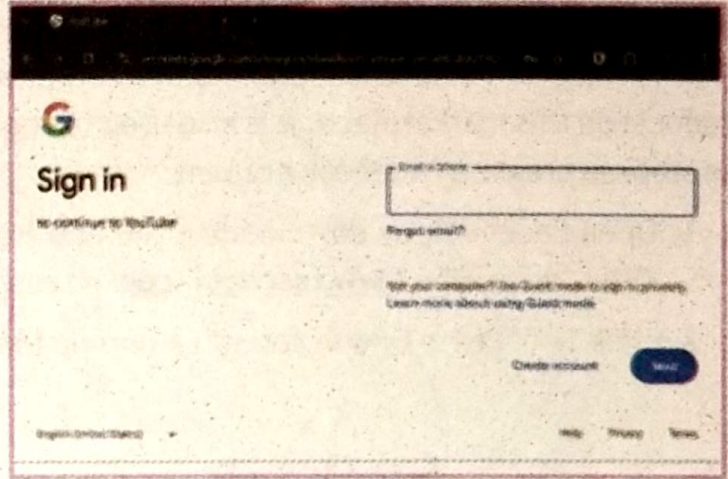

3

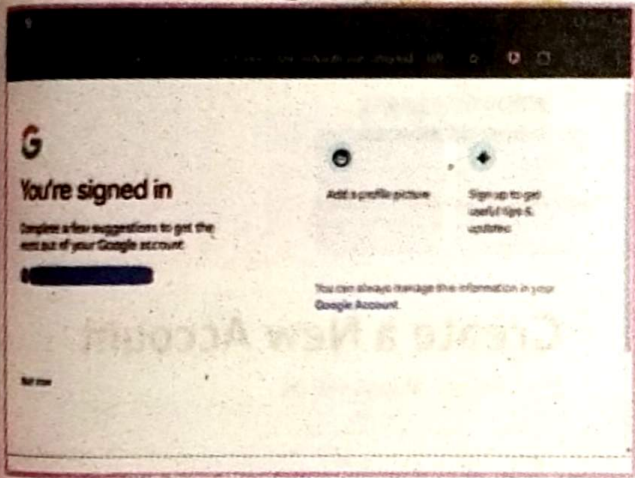

4

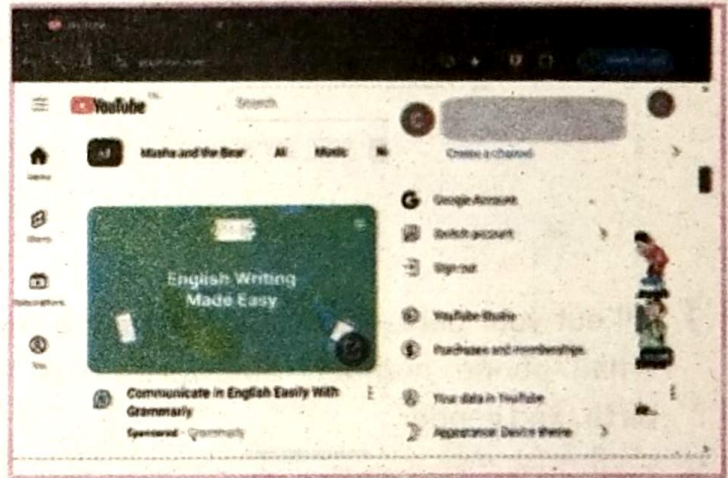

5

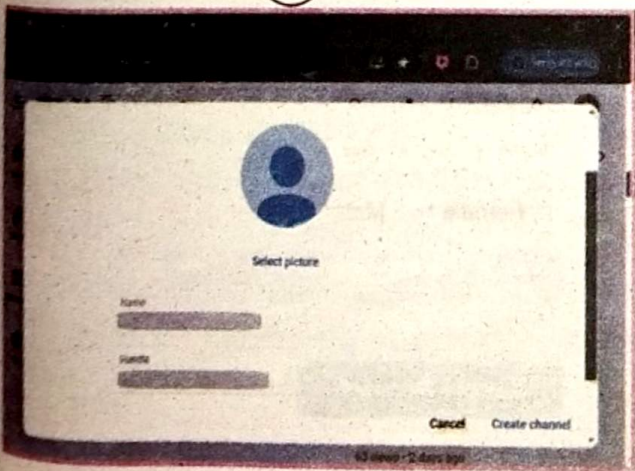

6

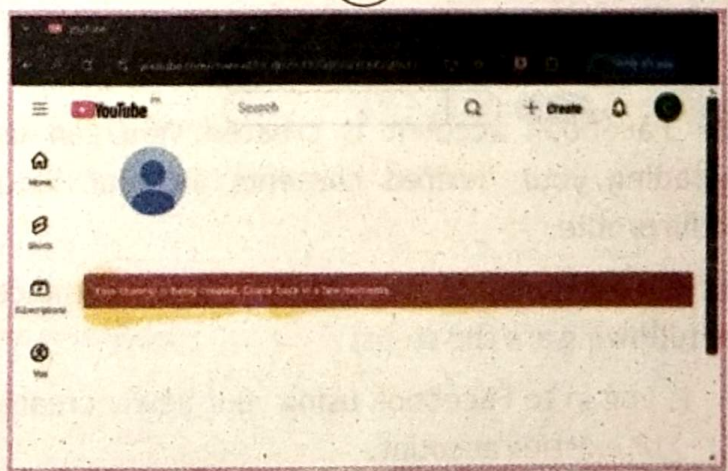

Facebook

This social media platform is used for networking purposes. You can use it by creating your personal profile on Facebook and sharing your pictures, videos, reels, and live streaming with trusted friends and family members. It is also used for marketing purposes. Various businesses can create their Facebook page, where they can display their messages, advertisements and other information. This information is visible to all the people who are members of that Facebook page. Companies can advertise by using reels, posters and video messages. There is a section of marketplace on Facebook. You can buy or sell new or used products on this marketplace. It is also used to announce various events as well. The following are the steps to create a Facebook account:



1. Open Facebook by downloading the app from the Google Play Store (Android), App Store (iOS), or visiting www.facebook.com on your browser.
2. Click on "Create New Account": A sign-up form will appear.

A screenshot of the Facebook login and sign-up page. On the left, the Facebook logo is displayed above the text "Connect with friends and the world around you on Facebook." On the right, there are input fields for "Email or Phone Number" and "Password", a blue "Log In" button, and a green "Create New Account" button. Below the "Create New Account" button, there is a link that says "Create a Page for a celebrity, band or business."

3. Fill out your personal details like your name, email/phone number, password, date of birth, and gender.
4. Click "Sign Up" option and follow the on-screen instructions.
5. To verify your account, enter the code sent to your email or phone number.

Your Facebook account is created. You can use uploading your desired contents on your social media profile.

To create a Facebook page to use the marketplace, the following are the steps:

1. Log in to Facebook using your newly created or existing account.

A screenshot of the "Create a New Account" form on Facebook. The title "Create a New Account" is in large, bold, black font, followed by the tagline "It's free and always will be." Below this are input fields for "First name" and "Last name", a "Mobile number or email" field, and a "New password" field. There is a "Birthday" section with dropdown menus for "Month", "Day", and "Year", and a note "Why do I need to provide my birthday?". Below the birthday section are radio buttons for "Female" and "Male". At the bottom, there is a green "Create Account" button and a small disclaimer: "By clicking Create Account, you agree to our Terms and that you have read our Data Policy, including our Cookie use. You may receive SMS notifications from Facebook and can opt out at any time."

2. Go to "Pages" from the left menu (on desktop) or in the menu bar (on mobile).
3. Click on "Create New Page."
4. Enter your page details i.e.
 - i. Page Name: Provide a suitable name for your page.
 - ii. Category: Select a category that fits your page's purpose.
 - iii. Description: Write a short description about your page.
5. Click on the "Create Page" button.
- 6 Upload a profile picture and cover photo to personalize your page.
7. Save the changes and publish your page.

Your Facebook page is now live. You can start posting content to engage with your audience.

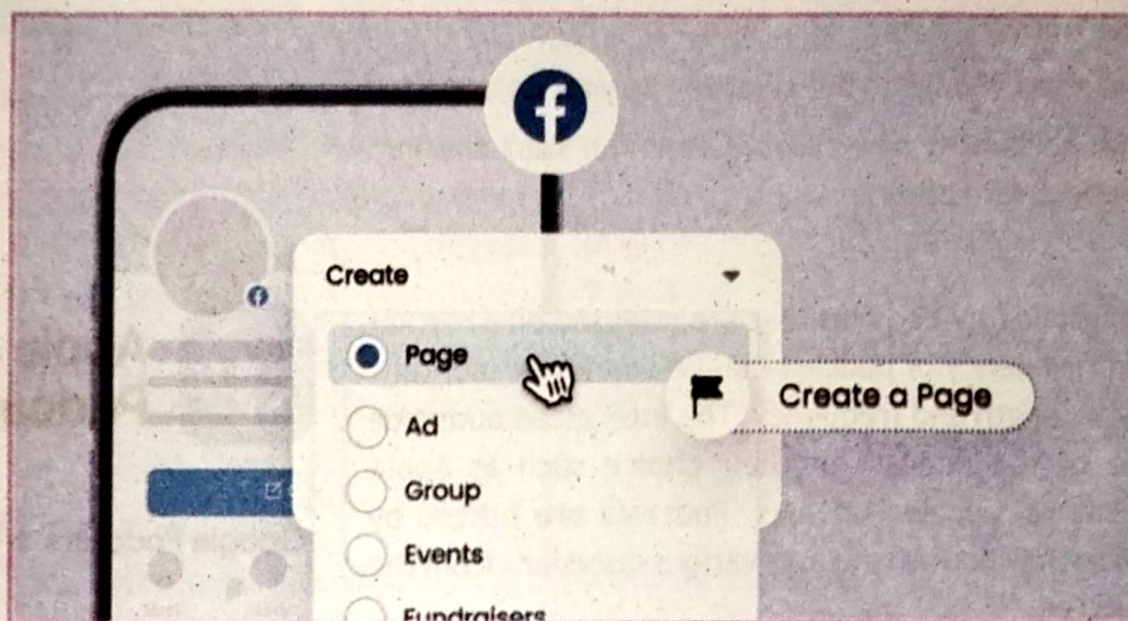

Instagram

This social media platform is used to share photos, videos, reels and stories. It is used to stay connected with friends and family members. It is used for community building as well. People with similar interests can create community and communicate with each other. It is a place to share your daily highlights and thoughts. Instagram is a hub for influencer marketing and sponsored content. It heavily relies on hashtags for discovery and categorization information. The following are the steps to create an Instagram account:



1. Open Instagram by downloading the app from the Google Play Store (Android), App Store (iOS), or visiting www.instagram.com on your browser.
2. Click or tap on "Sign Up."
3. Enter your details:

i. Email Address or Phone Number: Provide a valid email or phone number.

ii. Full Name: Enter your name.

iii. Username: Choose a unique username.

iv. Password: Create a strong password.

4. Follow the on-screen instructions to complete the registration process.
5. Add a profile picture by uploading an image or you can skip this step for later.
6. Fill in optional details like information about your work/page or website link if you have your personal business website.
7. Click or tap on "Done" to finish setting up your account.

Your Instagram account is now created. You can start sharing content to connect with others.

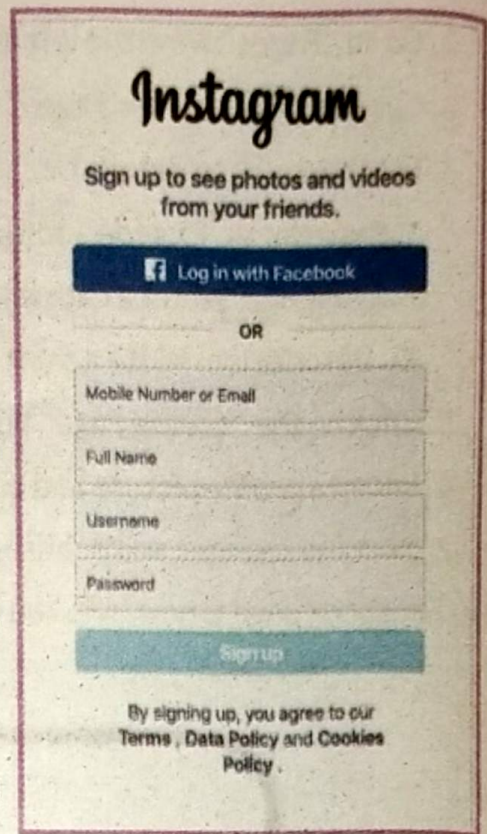

Podcast

It is a series of audio or video files that are released on a regular schedule. The frequency of podcast can be weekly or monthly. Podcasts vary in length and frequency. The interested audience can subscribe to the podcast of their choice such as Apple podcast, Spotify or Google Podcasts. Podcasts are hosted by some individuals in which he/she asks various questions from the guest. It is used for

showing interviews of celebrities online. Podcasts are usually live streamed; however, these can be downloaded as well. Sometimes the download feature is subject to the subscription as well. For example, if you want to create a podcast about the Quaid's day celebration held in your school on 25th December, you can follow the steps:

1. Decide the focus of your podcast, such as the highlights of the Quaid's Day celebration at your school, and plan what you'll talk about.
2. Write a simple script, starting with an introduction, talking about the event, and ending with a conclusion.
3. Use a smartphone, laptop, or any recording device in a quiet place.
4. Record your podcast by speaking clearly and including event highlights, sound clips, or interviews from teachers or students.
5. Edit your podcast using available video editing tools like CapCut/InShotAudacity/Anchor to trim, add music, or enhance the audio.
6. Give your podcast a title, such as "Quaid's Day Celebration at Govt School Lahore". The



title may include your name, the name of other student or teacher if he/she is part of this podcast. You can add name of your school as well. A short description about the podcast can also be provided.

7. Publish your podcast on a platform like YouTube, Facebook etc.

8. Share the link with classmates, teachers, and family to reach your audience.

X(Twitter)

It is a social media platform used for sharing short text messages called tweets. The name twitter was changed to X in July 2023. It is well known for its real-time update nature. Users share news, opinions and events more frequently as compared to other social media platforms. The short message known as tweets are limited to 280 characters. Users can mention other users' profile in their messages/tweets. It offers live streaming feature through

its Periscope feature. It also allows users to share short videos called Vines. It is a popular platform for news, discussions, and debates. Many celebrities and influencers use X to connect with their fans. The following are the steps to create a twitter account:

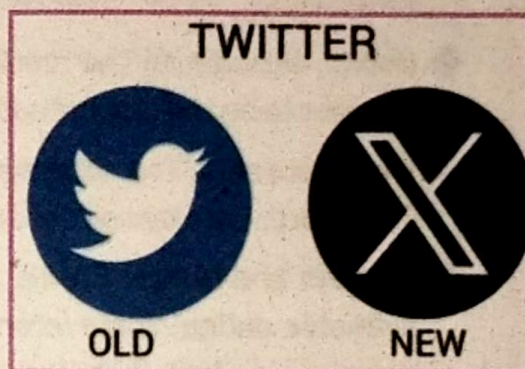

1. Open X (formerly Twitter) by downloading the app from the Google Play Store (Android), App Store (iOS), or visiting www.twitter.com on your browser.

2. Click or tap on "Sign Up."

3. Enter your details:

i. Name: Provide your name or the name you want to display.

ii. Phone Number or Email: Enter a valid phone number or email address.

iii. Set your Date of Birth and click or tap "Next."

4. Follow the on-screen instructions and review the suggested settings.

5. Create a strong password for your account.

6. Verify your account by entering the code sent to your email or phone number.

7. Customize your profile:

i. Profile Picture: Upload an image.

ii. Bio: Write a short description about yourself.

iii. Header Image: Add a background photo (optional).

8. Click or tap on "Done" to complete the setup.

Your X account is created. You can share your thoughts by tweeting and engaging with others on the platform.

The image shows a screenshot of the 'Create your account' form on the X app. At the top is the 'X' logo. Below it is the heading 'Create your account'. There are three input fields: 'Name', 'Phone', and 'Date of birth'. The 'Date of birth' field has a note: 'This will not be shown publicly. Confirm your own age, even if this account is for a business, a pet, or something else.' Below the 'Date of birth' field are three dropdown menus for 'Month', 'Day', and 'Year'. At the bottom is a blue button labeled 'Next'.

Unit Summary

- **Digital literacy:** It is the ability to create information in a digital environment. It refers to the ability to effectively use digital technologies to access information, evaluate it and convert it into meaningful and appealing ways. Now a days, data is available everywhere.
- **Information Collection:** We need to collect information to be communicated. This information can be collected through various sources like books, websites, and surveys.
- **Books:** Despite all the modern advancements in science and technology, books are still thought to be the most reliable and authentic source of information.
- **Web Sources:** The internet is the most common source of information now a days. Therefore, data can be collected from various websites
- **Surveys and Google Forms:** All the required information is not always present in books or available online. Some information is supposed to be collected by you. You can conduct a survey to collect that information. There are various methods to conduct a survey e.g. Design a google form and distribute it online to collect information or design a form in some document editor and distribute its printout to collect the information.
- **Digital Search/Information Literacy:** It is the ability to collect, understand and evaluate information from various sources.
- **Technical Skills:** It is the technical knowledge to use digital devices to communicate information in digital form. It is the skill to use smartphones, digital cameras, computers, microphones and related devices.
- **Communication:** Good communication skills clearly express thoughts and opinions. It also includes appropriate online behavior, etiquette, netiquette and other digital communication protocols.
- **Collaboration:** The use of digital devices involves networking and collaboration with other people across distances. It is achieved with the help of online meetings, document sharing, shared projects and activities etc.
- **Digital Content:** It can be in the form of a graphical poster, Facebook post, YouTube video or some research paper. The other form of digital contents can be presentations, videos, interactive stories, online tutorials, webinars, audiobooks, blog posts, infographics, animations, quizzes, simulations, and games etc.
- **Ethics and Responsibility:** The digital content has no boundaries. Therefore, higher standards of ethics and responsibility are required. These ethical standards involve cultural, social, and religious boundaries.
- **Key Ideas Extraction:** It is the most important information to be extracted from the available information and convert or present it into digital content.
- **Poster Designing:** It should be visually appealing. The color scheme should be according to

its topic/genre. For example, if a poster is designed to announce some social gatherings, it should give pleasing and lively feelings. Most of the time the response of the audience depends on the visual appeal of the digital content. The text and graphics should have some balance and alignment in size, colors, and other aspects.

- **Billboard Designing:** Simplicity is a key step in billboard designing as well. The billboards are huge in size and to attract the audience on the go. Therefore, an attractive billboard design will attract the audience otherwise it might be ignored and does not serve its purpose.
- **Social media as a communication Tool:** It is a very common and effective communication tool now a days. There is hardly any individual who is not using social media regularly. The most common usage of social media is audio and video calls and other necessary communication.
- **YouTube:** It is a social media platform commonly used for reels and video sharing. It is also used for live streaming. This platform is open for all the users across the world. People or users can upload their personal or professional video content.
- **Facebook:** It is used for networking purposes. You can use it by creating your personal profile on Facebook and sharing your pictures, videos, reels, and live streaming with trusted friends and family members. It is also used for marketing purposes. In the Facebook marketplace you can buy or sell new or used products on this marketplace. It is also used to announce various events as well.
- **Instagram:** It is used to share photos, videos, reels and stories. It is used to stay connected with friends and family members. It is used for community building as well. Instagram is a hub for influencer marketing and sponsored content. It heavily relies on hashtags for discovery and categorization information.
- **Podcast:** It is a series of audio or video files that are released on a regular schedule. Podcasts are hosted by some individuals in which he/she asks various questions from the guest. Podcasts are usually live streamed; however, these can be downloaded as well. Sometimes the download feature is subject to the subscription as well.
- **X(Twitter):** It is used for sharing short text messages called tweets. The short message known as tweets are limited to 280 characters. Users can mention other users' profile in their messages/tweets. It is a popular platform for news, discussions, and debates. Many celebrities and influencers use X to connect with their fans.

Exercise

Q1. Select the best answer for the following MCQs.

1. Which term is used for the ability to effectively use digital technologies to access information, evaluate it and convert it into meaningful and appealing format?

- a) Literacy b) Digital Literacy c) Social Media d) Information

What is the best way to collect information about a topic you are interested in?

- a) Ask your friend b) Read a random book
c) Search online and ask experts d) Guess the information

3. What is the benefit of using Google forms for information collection?

- a) Collect small amount of data b) Quickly analyze and summarize data
c) Get historical data d) Visualize data

4. What is the most important step to convert information into graphics?

- a) Decide the purpose of graphics tool b) Select the right tool
c) Check the local laws c) Decide the number of design elements

5. Which of the following is the primary purpose of billboard design?

- a) Showcase company's identity b) Entertain the audience
c) Grab attention of the audience d) Provide details of the company

6. What is the primary benefit of using podcast as a learning tool?

- a) To provide brief overview of a topic b) To present information in interactive way
c) To provide platform for international news d) To facilitate language learning

7. What is the role of a podcast host?

- a) To present their own opinion
b) To facilitate discussion and guide the conversation
c) To criticize the guest speaker
d) To praise the guest speaker

8. Which is the most common usage of social media besides audio and video calls?

- a) Education b) Sharing necessary updates
c) Translation d) Web Surfing

9. Which social media platform is mostly used for educational tutorials, skill teaching, and entertainment video contents?

- a) YouTube b) Facebook c) Instagram d) Podcast

10. Which social media platform is mostly used for news, discussion and opinions?

- a) Facebook b) YouTube c) X (Twitter) d) Instagram

Q2. Write answers of the following short response questions.

1. Differentiate between basic literacy and digital literacy.
2. Suggest strategies for integrating digital literacy into computer graphics.
3. Describe the role of books in verifying information for academic purposes.
4. Discuss the relationship between communication, collaboration, and digital literacy.
5. Do you think that X(Twitter) plays vital role in opinion making about any social issue? Support your answer with three arguments.
6. Outline effective strategies for identifying and countering online disinformation.
7. Differentiate between poster designing and billboard designing.
8. Define social media and describe the significance of YouTube and Facebook.

Q3. Write answers of the following extended response questions.

1. Explain the role of information collection in the field of digital literacy.
2. Analyze the key components of digital literacy and their significance.
3. Define information extraction and its purpose.
4. Illustrate the use of images and graphics in billboard design.
5. Discuss the impact of social media on contemporary communication, referencing YouTube and WhatsApp as examples.



Activity 1: Billboard Design Challenge:

Objective: To create a visually appealing billboard design for a popular brand.

Steps:

- Make groups of students according to the strength of the class. And let them choose a topic of their choice to design a billboard.
- Supervise them to collect necessary information about the design, company profile, product features for which they are going to design a billboard.
- Provide them with certain standard steps to follow at your convenience, so that all the students can follow the same pattern.
- Ask the groups to design the billboard with the help of chart papers and color.
- Ask them to convert it into digital form by using any graphics designing tool like Adobe Photoshop, Illustrator, CapCut or Canva.
- Put all the designs in an exhibition and display them at some appropriate place in your institution to encourage the efforts of the class.

Outcome: This activity will help students to understand the process of billboard designing. They will learn the utilization of this topic in their daily life.



Activity 2: Social media post for a popular brand:

Objective: To help students understand the significance of social media posts.

Steps:

- Divide the class into groups of 3 to 4 students each.
- Ask them to choose a topic of their choice from some popular fields of life around you, like bakery, super store, poultry form/shop, pizza shop, stationary shop etc.
- The students will collect data about their specific topic, for example the student with the topic of poultry form will collect the information that what are the positive features of poultry products which they can highlight in their Facebook post.
- The students will create the post with the help of collected information, and other digital tools like ChatGPT and Meta AI. They will create the post by using smartphones at home.
- Ask students to share this post as class project, on their Facebook profile. They will share the link with the teacher.
- The students will collect the response of other Facebook users on their post, and they will improve it according to positive criticism received as comments.

Outcome: This activity will help students to learn that how digital literacy will be effectively helpful for them to express their thoughts and messages.



Activity 3: Create a new product for a popular brand and present it to the company management using a presentation, create an Instagram post, and a short advertisement video:

Objective: To help students understand how new products are launched by the companies to increase their profits and grow the business.

Steps:

- This activity can be assigned to the students on an individual basis. Ask them to choose the popular business which they want to own in the future, like Apple, HP, Nike, Chanel, Honda, Service etc.
- Ask the student to brainstorm ideas for new products that align with the brand they chose.
- They will create a rough design of their idea with the help of paper and pencil.
- At next step they will write detailed description of the product from dimension to detailed working/usage
- Ask them to create a presentation and present in the class.
- After presentation, they will create an Instagram post and advertisement video and will share on their Instagram and Facebook profile as class activity.

Outcome: This activity will encourage the students to practice their creativity skills and boost their confidence for their future activities related to job/business.



Learning Objectives

- At the end of this unit students will be able to:
 - digital tools to conduct research to gather market insights for an entrepreneurial venture.
 - Identifying Problems and finding solutions.
 - pitch a business idea.



Introduction

What is research?

Research is a systematic process of inquiry aimed at discovering, interpreting, or revising facts, theories, or applications. It involves identifying a specific question or problem, gathering data or information, analyzing that data, and drawing conclusions based on the findings. Research can be conducted in various fields, including science, social science, humanities, and more

8.1 Qualitative vs. Quantitative Research | Differences, Examples & Methods

When collecting and analyzing data, quantitative research deals with numbers and statistics, while qualitative research deals with words and meanings. Both are important for gaining different kinds of knowledge.

Quantitative research

- ▶ Quantitative research is expressed in numbers and graphs. It is used to test or confirm theories and assumptions. This type of research can be used to establish generalizable facts about a topic.
- ▶ Common quantitative methods include experiments, observations recorded as numbers, and surveys with closed-ended questions.
- ▶ Quantitative research is at risk for research biases including information bias, omitted variable bias, sampling bias, or selection bias.

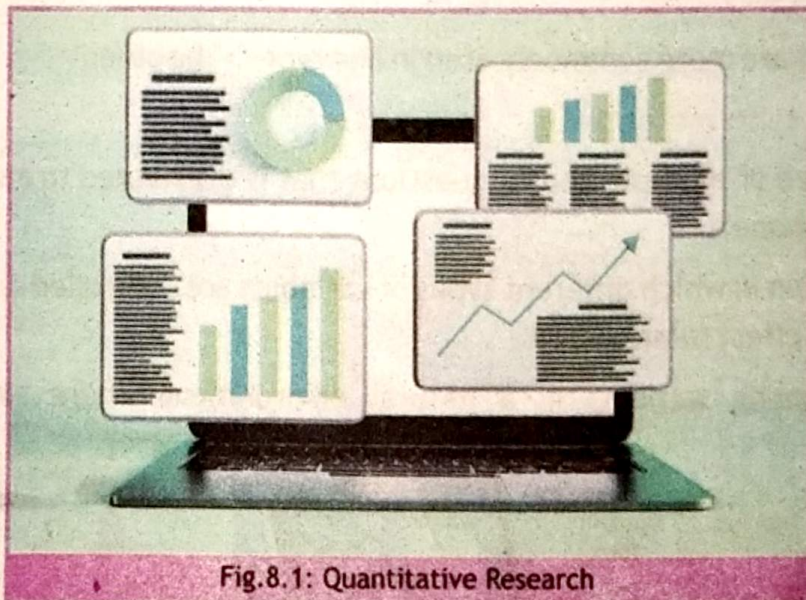

Fig.8.1: Quantitative Research

Qualitative research

- ▶ Qualitative research is expressed in words. It is used to understand concepts, thoughts or experiences. This type of research enables you to gather in-depth insights on topics that are not well understood.
- ▶ Common qualitative methods include interviews with open-ended questions, observations

described in words, and literature reviews that explore concepts and theories.



Fig.8.2: Qualitative Research

8.2 The differences between quantitative and qualitative research

Quantitative and qualitative research use different research methods to collect and analyze data, and they allow you to answer different kinds of research questions.

Data collection methods

Quantitative and qualitative data can be collected using various methods. It is important to use a data collection method that will help answer your research question(s).

Many data collection methods can be either qualitative or quantitative. For example, in surveys, observational studies or case studies, your data can be represented as numbers (e.g., using rating scales or counting frequencies) or as words (e.g., with open-ended questions or descriptions of what you observe).

However, some methods are more commonly used in one type or the other.

Quantitative data collection methods

- Surveys: List of closed or multiple choice questions that is distributed to a sample (online, in person, or over the phone).
- Experiments: Situation in which different types of variables are controlled and manipulated to establish cause-and-effect relationships.
- Observations: Observing subjects in a natural environment where variables can't be controlled.

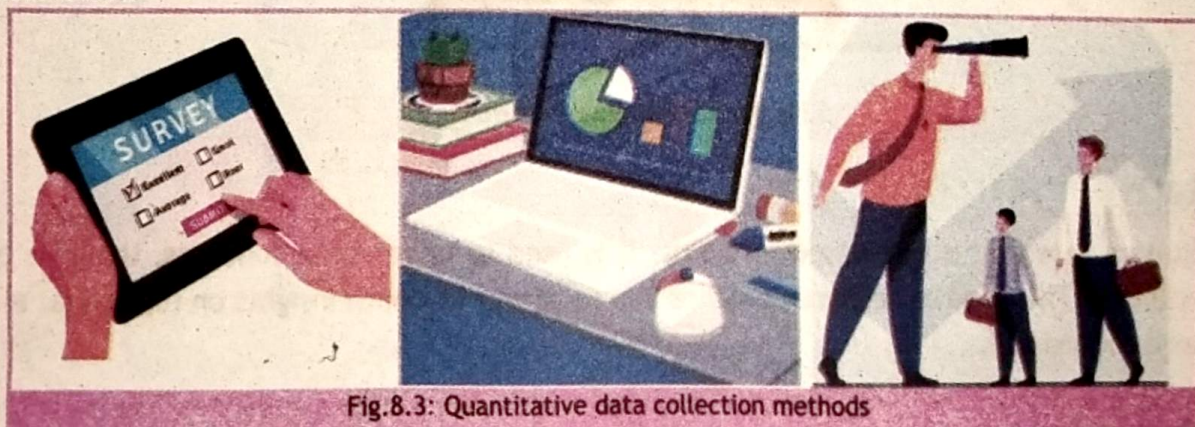

Fig.8.3: Quantitative data collection methods

Qualitative data collection methods

- Interviews: Asking open-ended questions verbally to respondents.
- Focus groups: Discussion among a group of people about a topic to gather opinions that can be used for further research.
- Ethnography: Participating in a community or organization for an extended period of time to closely observe culture and behavior.
- Literature review: Survey of published works by other authors.

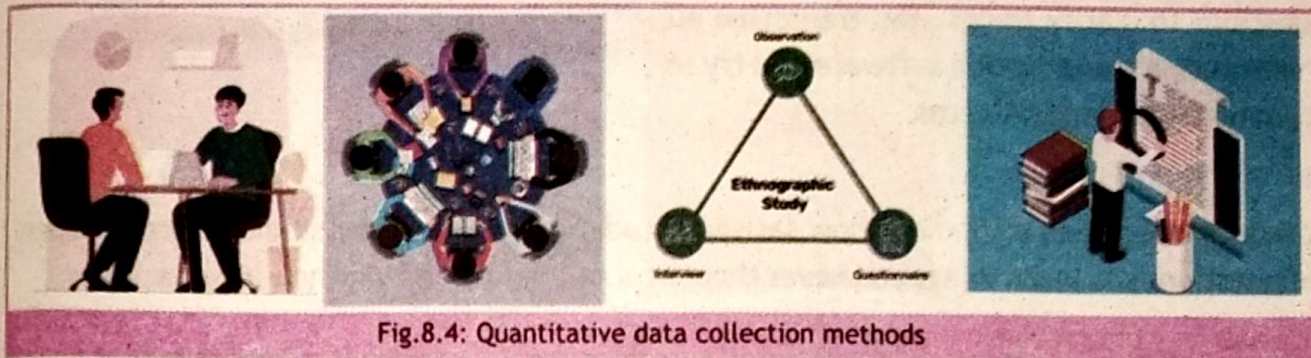

Fig.8.4: Quantitative data collection methods

When to use qualitative vs. quantitative research

A rule of thumb for deciding whether to use qualitative or quantitative data is:

- Use quantitative research if you want to confirm or test something (a theory or hypothesis)
- Use qualitative research if you want to understand something (concepts, thoughts, experiences)

For most research topics you can choose a qualitative, quantitative or mixed methods approach. Which type you choose depends on, among other things, whether you're taking an inductive vs. deductive research approach; your research question(s); whether you're doing experimental, correlational, or descriptive research; and practical considerations such as time, money, availability of data, and access to respondents.

Research question How satisfied are students with their studies?

Quantitative research approach

You survey 300 students at your university and ask them questions such as: "on a scale from 1-5, how satisfied are you with your professors?"

You can perform statistical analysis on the data and draw conclusions such as: "on average students rated their professors 1.4".

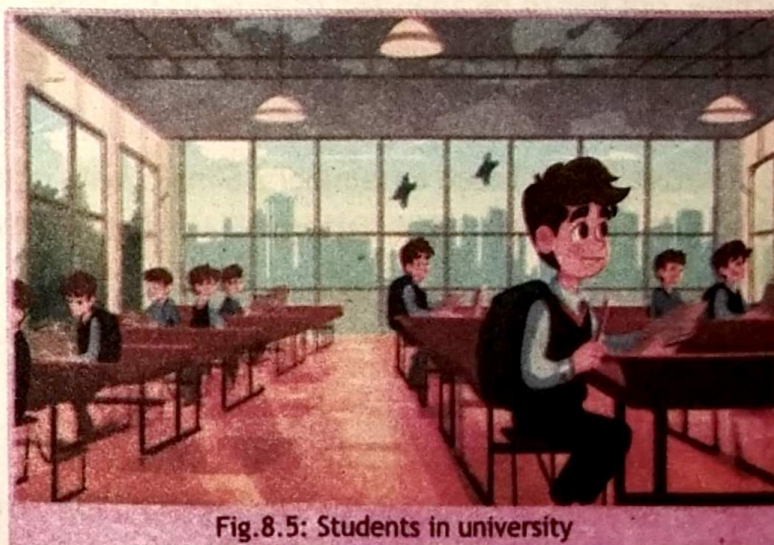

Fig.8.5: Students in university

Qualitative research approach

You conduct in-depth interviews with 15 students and ask them open-ended questions such as: "How satisfied are you with your studies?", "What is the most positive aspect of your study program?" and "What can be done to improve the study program?"

Based on the answers you get you can ask follow-up questions to clarify things. You transcribe all interviews using transcription software and try to find commonalities and patterns.

Mixed methods approach

You conduct interviews to find out how satisfied students are with their studies. Through open-ended questions you learn things you never thought about before and gain new insights. Later, you use a survey to test these insights on a larger scale.

It's also possible to start with a survey to find out the overall trends, followed by interviews to better understand the reasons behind the trends.

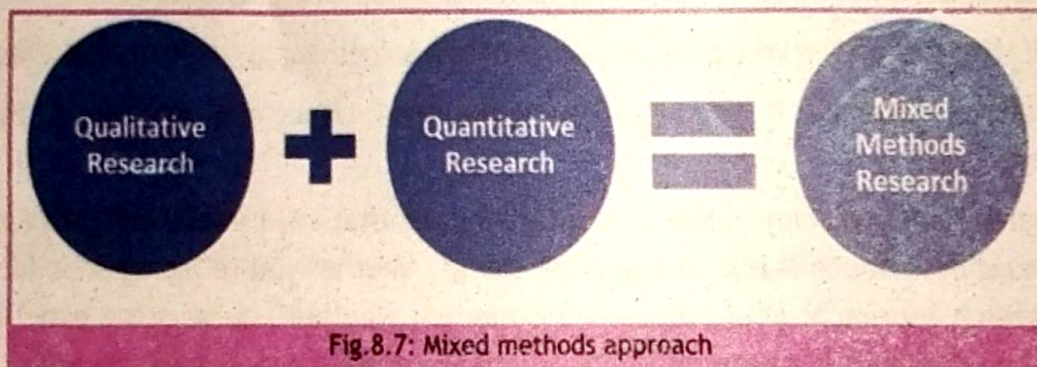
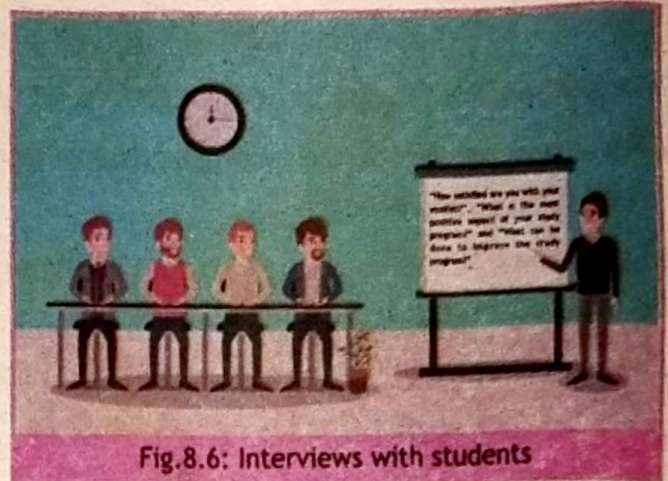

How to analyze qualitative and quantitative data

Qualitative data (soft data) or quantitative data (hard data) by itself can't prove or demonstrate anything, but has to be analyzed to show its meaning in relation to the research questions. The method of analysis differs for each type of data.

Analyzing quantitative data

Quantitative data is based on numbers. Simple math or more advanced statistical analysis is used to discover commonalities or patterns in the data. The results are often reported in graphs and tables.

Applications such as Excel, SPSS, or R can be used to calculate things like:

- Average scores (means)
- The number of times a particular answer was given
- The correlation or causation between two or more variables
- The reliability and validity of the results

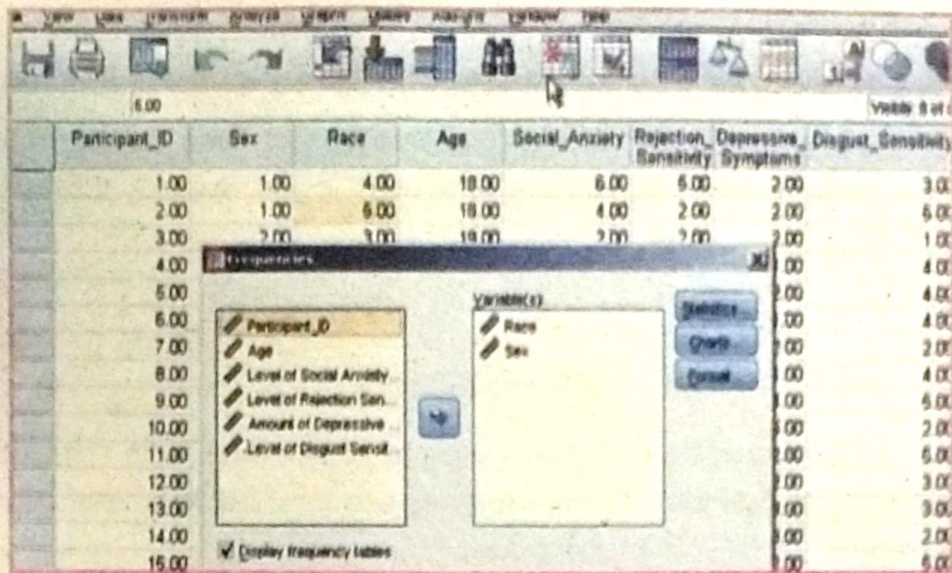

Fig.8.8: Quantitative analysis through SPSS

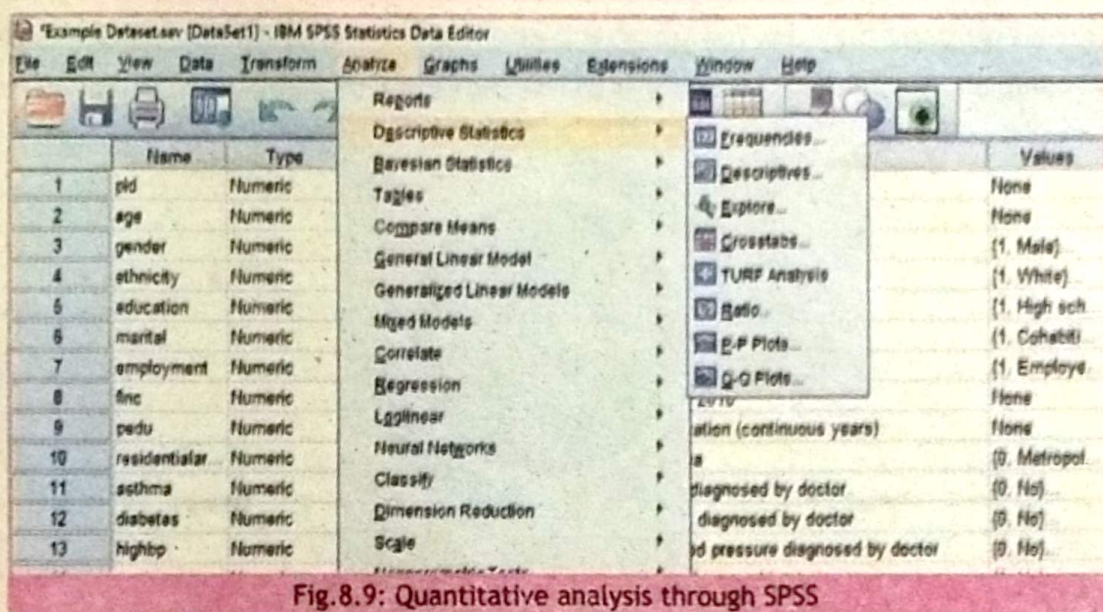

Fig.8.9: Quantitative analysis through SPSS

Analyzing qualitative data

Qualitative data is more difficult to analyze than quantitative data. It consists of text, images or videos instead of numbers.

Some common approaches to analyzing qualitative data include:

- Qualitative content analysis: Tracking the occurrence, position and meaning of words or phrases
- Thematic analysis: Closely examining the data to identify the main themes and patterns
- Discourse analysis: Studying how communication works in social contexts

How do I decide which method to use?

The research methods you use depend on the type of data you need to answer your research question.

- If you want to measure something or test a hypothesis, use quantitative methods. If you want to explore ideas, thoughts and meanings, use qualitative methods.

- If you want to analyze a large amount of readily available data, use secondary data. If you want data specific to your purposes with control over how it is generated, collect primary data.
- If you want to establish cause and effect relationships between variables, use experimental methods. If you want to understand the characteristics of research subject, use descriptive methods.

8.3 Questionnaire Design | Methods, Question Types & Examples

A questionnaire is a list of questions or items used to gather data from respondents about their attitudes, experiences, or opinions. Questionnaires can be used to collect quantitative and/or qualitative information.

Questionnaires are commonly used in market research as well as in the social and health sciences. For example, a company may ask for feedback about a recent customer service experience, or psychology researchers may investigate health risk perceptions using questionnaires.

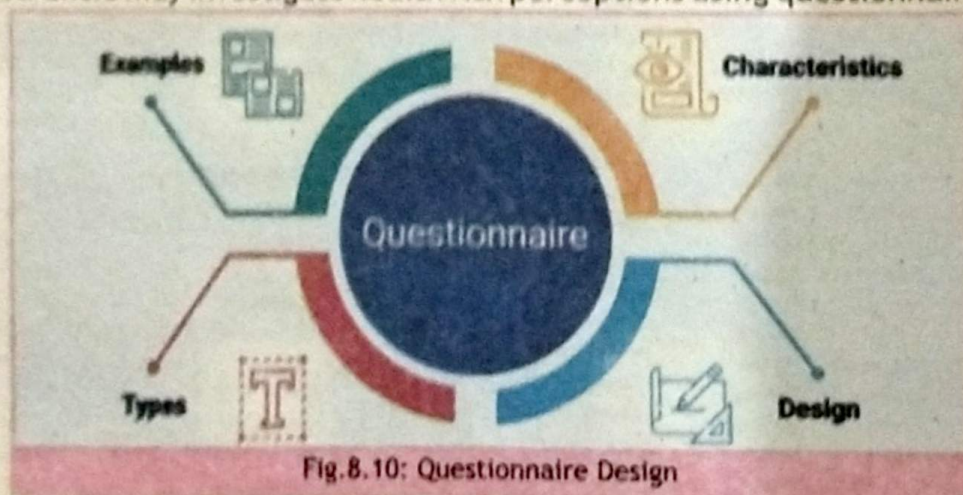

Fig.8.10: Questionnaire Design

Questionnaires vs. Surveys

A survey is a research method where you collect and analyze data from a group of people.

A questionnaire is a specific tool or instrument for collecting the data.

Designing a questionnaire means creating valid and reliable questions that address your research objectives, placing them in a useful order, and selecting an appropriate method for administration.

But designing a questionnaire is only one component of survey research. Survey research also involves defining the population you're interested in, choosing an appropriate sampling method, administering questionnaires, data cleansing and analysis, and interpretation.

	Survey	Questionnaire
Individual questions	✓	✓
Used for gathering data	✓	✗
Analyzes responses	✓	✗
Provides insights about an individual	✓	✓
Provides insights about a group of people	✓	✗

Fig.8.11: Questionnaires vs. Surveys

Sampling is important in survey research because you'll often aim to generalize your results to the population. Gather data from a sample that represents the range of views in the population for externally valid results. There will always be some differences between the population and the sample, but minimizing these will help you avoid several types of research bias, including sampling bias, ascertainment bias, and undercoverage bias.

Questionnaire methods

Questionnaires can be self-administered or researcher-administered. Self-administered questionnaires are more common because they are easy to implement and inexpensive, but researcher-administered questionnaires allow deeper insights.

Self-administered questionnaires

Self-administered questionnaires can be delivered online or in paper-and-pen formats, in person or through mail. All questions are standardized so that all respondents receive the same questions with identical wording.

Self-administered questionnaires can be:

- cost-effective
- easy to administer for small and large groups
- anonymous and suitable for sensitive topics
- self-paced

but they may also be:

- unsuitable for people with limited literacy or verbal skills
- susceptible to a nonresponse bias (most people invited may not complete the questionnaire)
- biased towards people who volunteer because impersonal survey requests often go ignored.

Researcher-administered questionnaires

Researcher-administered questionnaires are interviews that take place by phone, in-person, or online between researchers and respondents.

Researcher-administered questionnaires can:

- help you ensure the respondents are representative of your target audience
- allow clarifications of ambiguous or unclear questions and answers
- have high response rates because it's harder to refuse an interview when personal attention is given to respondents

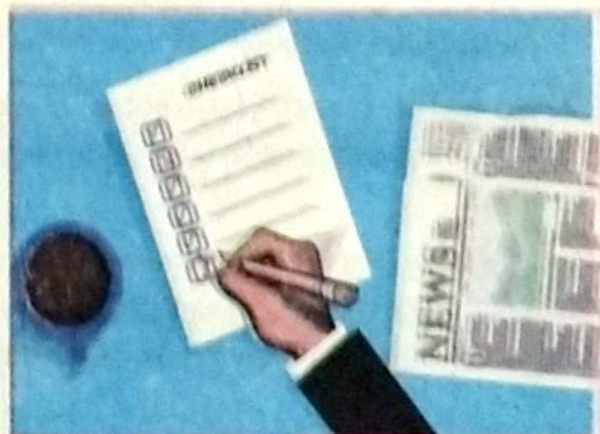

Fig. 8.12: Self-administered questionnaires



Fig. 8.13: Researcher-administered questionnaires

Surveys for administrative questionnaires can be limiting in terms of resources. They are:

- costly and time-consuming to perform
- more difficult to analyse if you have qualitative responses
- likely to contain experimenter bias or demand characteristics
- likely to encourage social desirability bias in responses because of a lack of anonymity

Open-ended vs. closed-ended questions

Your questionnaire can include open-ended or closed-ended questions or a combination of both. Using closed-ended questions limits your responses, while open-ended questions enable a broad range of answers. You'll need to balance these considerations with your available time and resources.

Closed-ended questions

Closed-ended, or restricted-choice, questions offer respondents a fixed set of choices to select from. Closed-ended questions are best for collecting data on categorical or quantitative variables.

Categorical variables can be nominal or ordinal. Quantitative variables can be interval or ratio. Understanding the type of variable and level of measurement means you can perform appropriate statistical analyses for generalizable results.

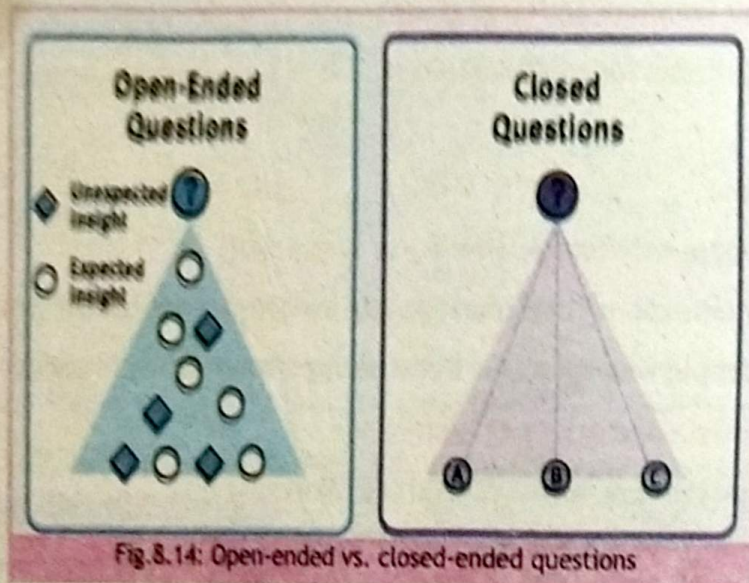

Fig. 8.14: Open-ended vs. closed-ended questions

Examples of closed-ended questions for different variables

Nominal variables include categories that can't be ranked, such as race or ethnicity. This includes binary or dichotomous categories.

It's best to include categories that cover all possible answers and are mutually exclusive. There should be no overlap between response items.

In binary or dichotomous questions, you'll give respondents only two options to choose from.

Example: Nominal variables What is your race?

- a) White b) African c) American d) Asian

Are you satisfied with the current work-from-home policies?

Yes

b) No

Ordinal variables include categories that can be ranked. Consider how wide or narrow a range

you'll include in your response items, and their relevance to your respondents.

Example: Ordinal variables What is your age?

a) 16-35

b) 36-60

c) 61-75

d) 76 or older

Rating scale questions collect ordinal data using rating scales with 5 or 7 points.

Example: Likert-type questions How satisfied or dissatisfied are you with your online shopping experience today?

a) Very dissatisfied

b) Somewhat dissatisfied

c) Somewhat satisfied

d) Very satisfied

When you have four or more Likert-type questions, you can treat the composite data as quantitative data on an interval scale. Intelligence tests, psychological scales, and personality inventories use multiple Likert-type questions to collect interval data.

Pros and cons of closed-ended questions

Well-designed closed-ended questions are easy to understand and can be answered quickly. However, you might still miss important answers that are relevant to respondents. An incomplete set of response items may force some respondents to pick the closest alternative to their true answer. These types of questions may also miss out on valuable detail.

To solve these problems, you can make questions partially closed-ended, and include an open-ended option where respondents can fill in their own answer.

Open-ended questions

Open-ended, or long-form, questions allow respondents to give answers in their own words. Because there are no restrictions on their choices, respondents can answer in ways that researchers may not have otherwise considered. For example, respondents may want to answer "multiracial" for the question on race rather than selecting from a restricted list.

Example: Open-ended questions

▶▶▶ How do you feel about open science?

▶▶▶ How would you describe your personality?

▶▶▶ In your opinion, what is the biggest obstacle for productivity in remote work?

Open-ended questions have a few disadvantages.

They require more time and effort from respondents, which may deter them from completing the questionnaire.



Activity 1

Discuss in Class different types of variables which we deal in our daily life.

Are you satisfied with the current work-from-home policies?

a) Yes

b) No

Ordinal variables include categories that can be ranked.

Consider how wide or narrow a range

you'll include in your response items, and their relevance to your respondents.

Example: Ordinal variables What is your age?

a) 16-35

b) 36-60

c) 61-75

d) 76 or older

Likert scale questions collect ordinal data using rating scales with 5 or 7 points.

Example: Likert-type questions How satisfied or dissatisfied are you with your online shopping experience today?

a) Very dissatisfied

b) Somewhat dissatisfied

c) Somewhat satisfied

d) Very satisfied

When you have four or more Likert-type questions, you can treat the composite data as quantitative data on an interval scale. Intelligence tests, psychological scales, and personality inventories use multiple Likert-type questions to collect interval data.

Pros and cons of closed-ended questions

Well-designed closed-ended questions are easy to understand and can be answered quickly. However, you might still miss important answers that are relevant to respondents. An incomplete set of response items may force some respondents to pick the closest alternative to their true answer. These types of questions may also miss out on valuable detail.

To solve these problems, you can make questions partially closed-ended, and include an open-ended option where respondents can fill in their own answer.

Open-ended questions

Open-ended, or long-form, questions allow respondents to give answers in their own words. Because there are no restrictions on their choices, respondents can answer in ways that researchers may not have otherwise considered. For example, respondents may want to answer "multiracial" for the question on race rather than selecting from a restricted list.

Example: Open-ended questions

▶▶▶ How do you feel about open science?

▶▶▶ How would you describe your personality?

▶▶▶ In your opinion, what is the biggest obstacle for productivity in remote work?

Open-ended questions have a few disadvantages.

They require more time and effort from respondents, which may deter them from completing the questionnaire.



Activity 1

Discuss in Class different types of variables which we deal in our daily life.

For researchers, understanding and summarizing responses to these questions can take a lot of time and resources. You'll need to develop a systematic coding scheme to categorize answers, and you may also need to involve other researchers in data analysis for high reliability.

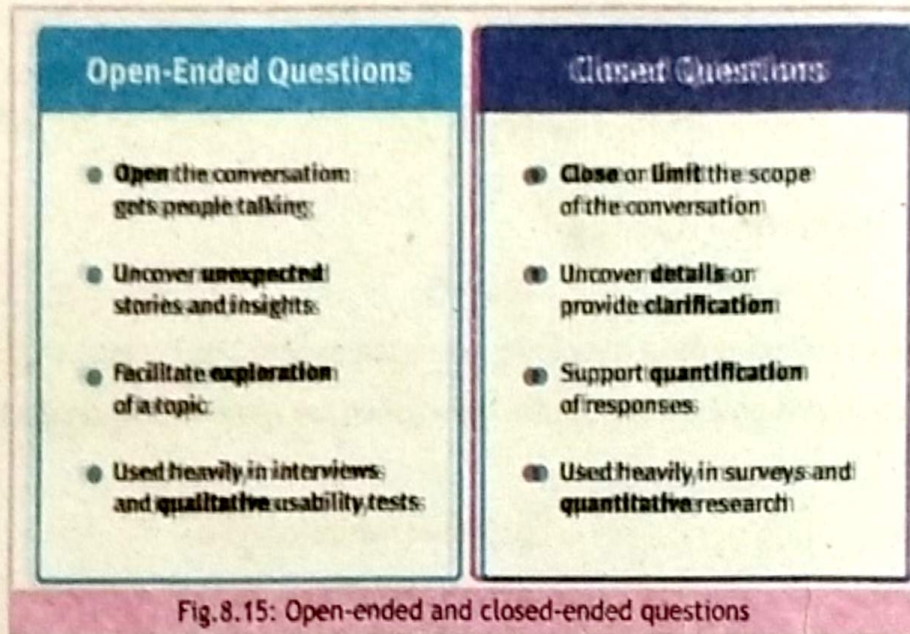

Question wording

Question wording can influence your respondents' answers, especially if the language is unclear, ambiguous, or biased. Good questions need to be understood by all respondents in the same way (reliable) and measure exactly what you're interested in (valid).

Use clear language

You should design questions with your target audience in mind. Consider their familiarity with your questionnaire topics and language and tailor your questions to them.



For readability and clarity, avoid jargon or overly complex language. Don't use double negatives because they can be harder to understand.

Use balanced framing

Respondents often answer in different ways depending on the question framing. Positive frames are interpreted as more neutral than negative frames and may encourage more socially desirable answers.

Example: Positive vs negative frames

Positive frame	Negative frame
Should protests of pandemic-related restrictions be allowed?	Should protests of pandemic-related restrictions be forbidden?

Use a mix of both positive and negative frames to avoid research bias, and ensure that your question wording is balanced wherever possible.

Unbalanced questions focus on only one side of an argument. Respondents may be less likely to oppose the question if it is framed in a particular direction. It's best practice to provide a counter argument within the question as well.

Example: Unbalanced vs balanced frames

Unbalanced	Balanced
Do you favor...?	Do you favor or oppose...?
Do you agree that...?	Do you agree or disagree that...?

Avoid leading questions

Leading questions guide respondents towards answering in specific ways, even if that's not how they truly feel, by explicitly or implicitly providing them with extra information.

It's best to keep your questions short and specific to your topic of interest.

Example: Leading questions

- » Experts agree that a well-balanced diet provides sufficient vitamins and minerals, and multivitamins and supplements are not necessary or effective. Do you agree or disagree that multivitamins are helpful for balanced nutrition?

8.4 What is Market Validation?

Market validation is the process of determining if there's a need for your product in your target market. Validating your business idea can enable you to reasonably predict whether people will buy your product or service, and whether your business will be profitable.

It's important to validate your idea early in the entrepreneurial process to ensure you don't waste time and resources creating a product that isn't a good fit. Securing market validation can also instill confidence among investors, crowdfunding, and banks that are considering funding your startup.

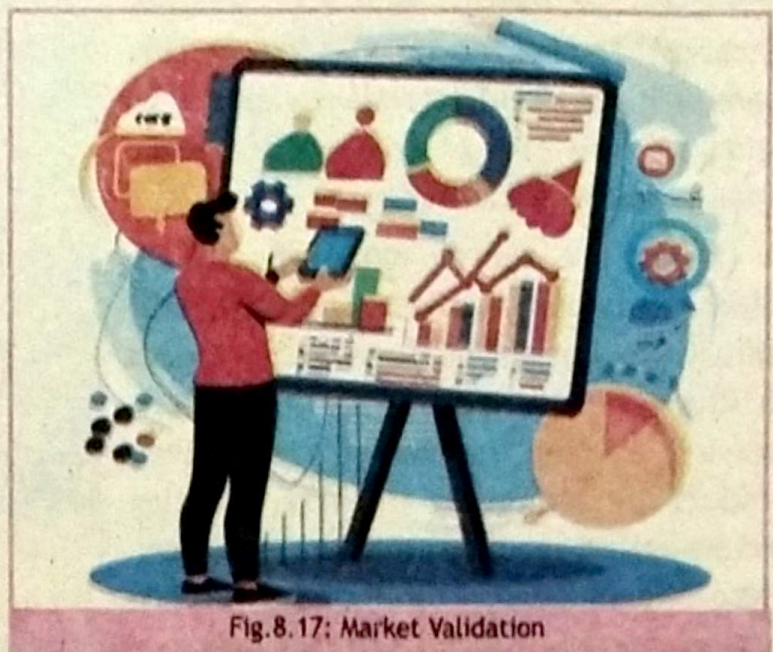

Fig.8.17: Market Validation

By going through the process of validating your business idea, you can gain a deeper understanding of how your product does or doesn't meet your target customers' pain points. The insights you gain can help you create an offering that not only addresses your market segment's needs, but earns you your first paying customers.

Here are five steps to determine the market validity of your venture.

5 Steps To Determine Market Validation

1. Write Down Goals, Assumptions, and Hypotheses

Writing down the goals of your business is the first step in market validation. The process of articulating your vision can illuminate any assumptions you have

provide an end goal.

yourself:

- What's the value of my product?
- Who's the target audience, and what assumptions have I made about them?
- What differentiates my product from existing ones?
- What hypotheses do I have about my product, pricing, and business model?

Answering these questions can help you communicate the value and differentiating factors of your product, and illuminate assumptions and hypotheses you've made that are yet to be tested and verified.

2. Assess Market Size and Share

Before moving forward with your venture, estimate the size of your target market and the share of it you could potentially capture. By doing so, you can gauge your business's potential and justify its launch.

In the online course *Entrepreneurship Essentials*, Harvard Business School Professor William Sahlman uses mattress retailer Casper to illustrate this idea. In 2014, Casper's founders assessed the market size for their product by comparing its differentiating factors against the larger market. For Casper, these differentiating factors included its online business model, 100-day return window, and the viscoelastic foam material used in its mattresses.

Based on statistics for the mattress market at the time—including units sold per year, the percentage of the market owned by foam mattresses, and the number of mattress retailers that were e-commerce brands—Casper's founders narrowed down which segments they should target, and determined they could own a few percentage points of the total mattress market share.

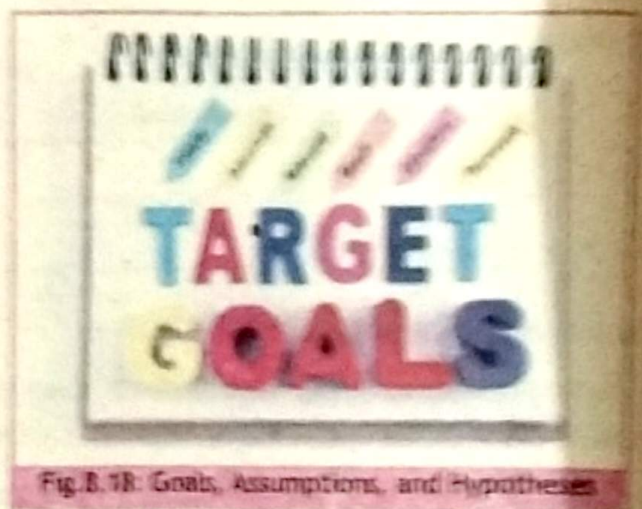

Fig. 8.18: Goals, Assumptions, and Hypotheses

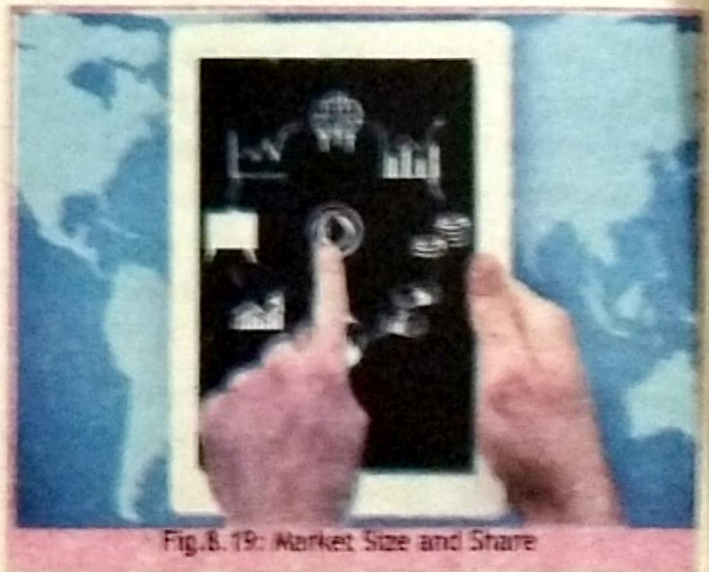

Fig. 8.19: Market Size and Share

3. Research Search Volume of Related Terms

Another way to gauge the market validity of your business idea is to research the monthly search volume of terms related to your product or mission. When consumers need a product or service, they often use a search engine to see what the market has to offer.

If there's not a lot of search volume surrounding your product, use terms that express customer intent. For instance, if you design a mattress made from a new, extra supportive material, you could look up how many people search for "best mattress for lower back pain sufferers."

This type of search volume for a longer, specific query isn't negligible. In fact, it can be used to bolster your hypothesis that there's a need for your product.

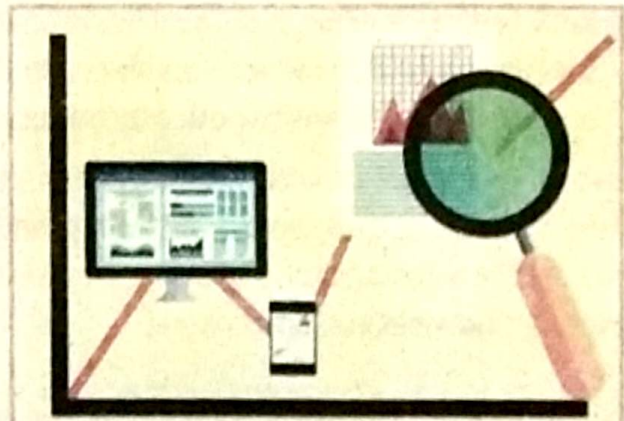

Fig.8.20: Research Search Volume of Related Terms

4. Conduct Customer Validation Interviews

Conducting interviews with your target market segment can be an effective way to learn about your product's potential. This initiative might include hiring a market research company to conduct focus groups, sending out an online survey, or simply requesting a conversation with someone.

Ask potential customers about their motivations, preferences, needs, and the products they currently use. Circle back to the list you created in the first step of the market validation process, and frame any assumptions or hypotheses you made as questions to your interviewees. Be open to the feedback you receive and record it for future use.

The feedback may reflect that your product doesn't have strong market validity, in which case, you can use it to improve your offering and repeat the market validation process.



Fig.8.21: Conduct Customer Validation Interviews

5. Test Your Product or Service

Once you've determined there's space for your product in the market, ensure you're putting the most useful, intuitive version of it into the world. You can achieve this through alpha and beta testing.

Alpha testing is when internal employees test a product in a staged setting. The purpose of alpha testing is to eliminate any bugs, issues, or



Fig.8.22: Test Your Product or Service

idiosyncrasies in the product before it's available to outside users.

- Beta testing is when a product is tested by a limited group of real, external users who are specifically told to identify problems. In the case of a software or app, beta testing might be open to the public with a notice letting users know the version they're testing is unfinished.

Testing your product with real users can prove invaluable when assessing market validity. If there's a need in the market, but your product is faulty, complex, or difficult to use, customers may opt for a competitor's offering. The feedback you get from beta testers can help you better leverage and meet customer needs.

8.5 How to Use Research to Create Customer Profiles

Businesses often use a combination of quantitative and qualitative research, such as data analysis, surveys, and customer interviews, to create and continuously update their ideal customer profile.

Customer profiling is an essential aspect of serving customers. But what is customer profiling?

As a small business owner, understanding customers' specific demographics, tendencies, and pain

points is indispensable in meeting their needs. Defining your ideal customer entails gathering and analyzing data about your customers' characteristics, behaviors, attributes, and needs. This information is used to create profiles representing your customer segments.

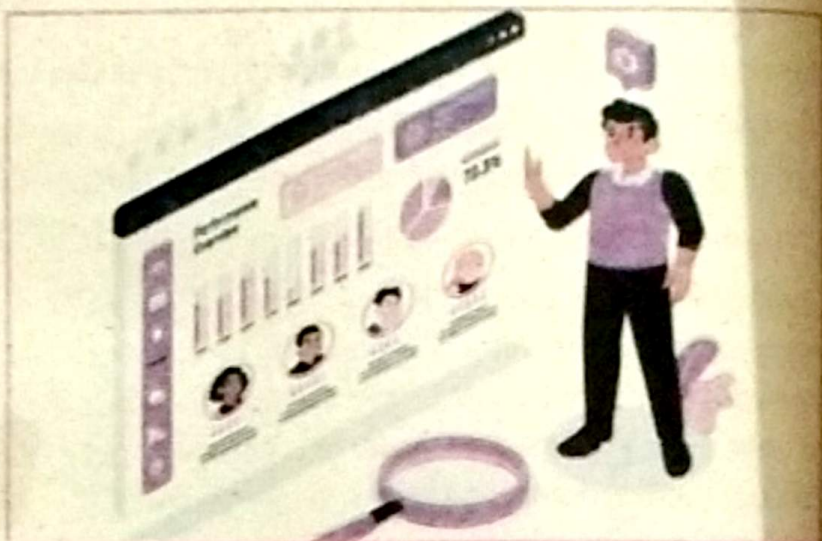

Fig.8.23: Research to Create Customer Profiles

Products/Services Used

This section of the customer profile template describes which of your services your customers rely on and how they use them. You can also include other products or services customers use with your service.

If your product can be integrated with another service and customers are successfully meshing your service with another, add that to this section. This will help you better market to other companies or individuals later.



Fig.8.24: Customer Products/Services Used

Demographics

Your customers' demographics are an essential piece of your customer profile, include your customer's career, industry, location, and gender identity.

For Example, if i run a music backline rental company, and my customers range from High Schools to Weddings to Touring Bands. I've found that outlining the demographics of each customer segment helps me better anticipate their needs.

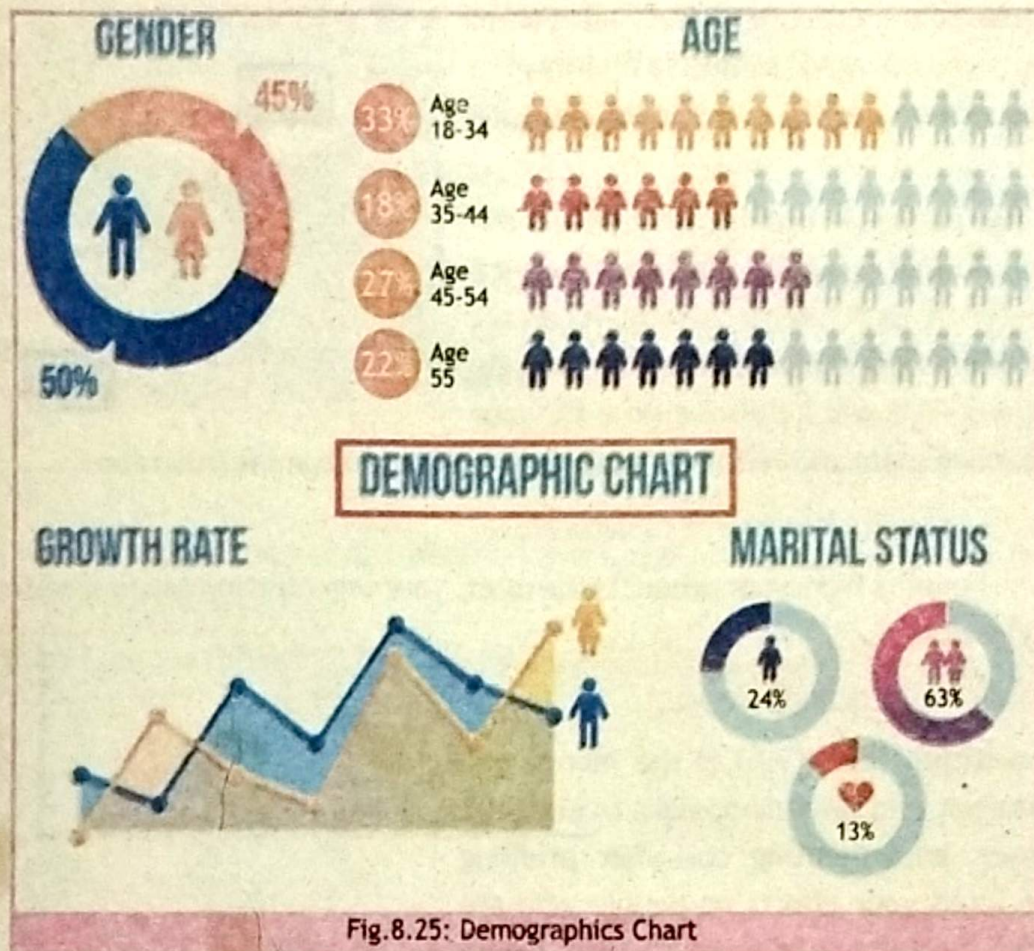

Fig.8.25: Demographics Chart

Customer Benefits

Your customer profile should also include a list of benefits customers receive by using your product or service. How does your product or service provide value to your customers?

Think about how your product or service adds value for your customers and describe it in this section. The best way to answer this question is to ask your customer base. Compile and compare their answers and add a summary here.

Customer Profiling Benefits

Creating customer profiles is crucial for taking your business to the next level. 66% of customers expect companies to understand their needs; customer profiling helps you do that.

It helps all departments become more efficient.

The benefits of customer profiling are impactful across your entire company. Each department in your company will use your customer profiles differently, but they will improve the bottom line.

➤ **Marketing:** Understanding the client is vital to creating engaging advertisements or emails for potential prospects and current clients. Marketers use customer profiles to customize messaging to most effectively speak to customer needs.

➤ **Sales:** With a customer profile in hand, your sales team will be able to highlight customer pain points and help better sell your product or service as the solution to their problems. Your sales team may even use the customer profile to find ways to create connections with current and future clients.

➤ **Support:** The customer profile contains all the necessary information your customer service team will need to assist clients in need. It can act as a record of queries, complaints, and previously tried solutions. This will help save time for your customer service team and keep everyone involved from becoming frustrated.



Fig.8.26: Customer Profiling Benefits

It allows you to identify better-fit prospects.

By knowing who benefits from your products the most, your organization can find better prospects and increase close rates.

It lowers customer acquisition cost.

Customer acquisition cost (CAC) is the money you spend on marketing and sales campaigns to attract a single customer. Implementing customer profiling allows you to focus your efforts on people who are more likely to become customers, which brings customer acquisition costs down in the long run.

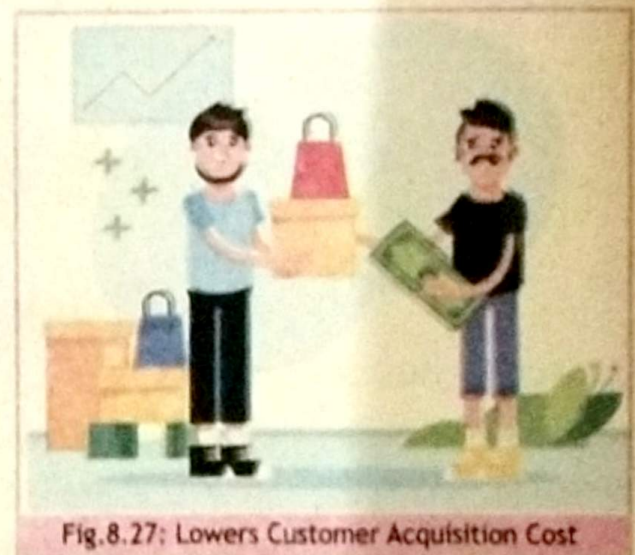

Fig.8.27: Lowers Customer Acquisition Cost



Activity 2

Design a Media Marketing Campaign for a Product and Calculate its Customer Acquisition Cost (CAC)

It empowers you to serve customers better.

Knowing your customers is critical to serving them better. I found this accurate, having worked on the Support Team at HubSpot at the beginning of my career. We always kept detailed notes on each customer, including the issues they had in the past and their needs/goals. Armed with this information, I was much better equipped to meet customers where they were and guide them to success.

You can predict issues before they arise, provide

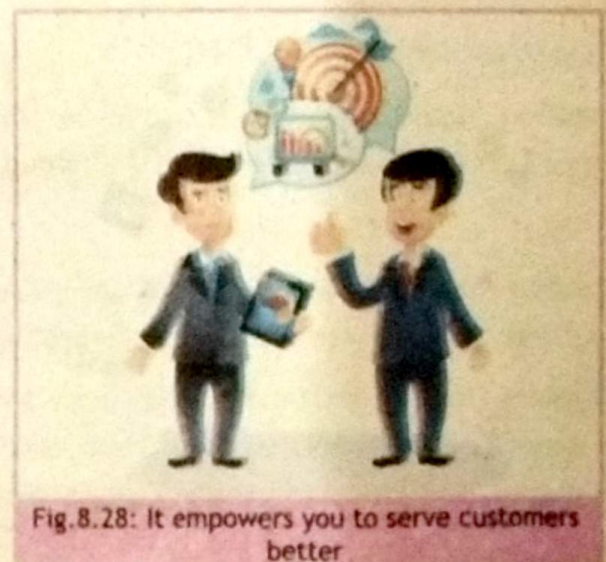

Fig.8.28: It empowers you to serve customers better

practical self-help resources, and better align with their needs if they reach out to your service team.

It reduces customer churn.

Customer churn refers to losing customers. We can all agree we want to keep that number as low as possible!

By creating strong customer profiles from the start, you can attract and serve customers who actually want to use your product or service – reducing customer churn in both the short and long term.

Now that you know the benefits of customer profiling, which data should you gather for your customer profiles?

Let's take a look.

Demographic

Demographic data are the concrete characteristics of a customer and can be used to understand consumer behavior, albeit broadly.

Demographics include the following traits (and more):

- Age.
- Sex.
- Job title.
- Income.
- Education level.
- Family status.

For example, my music backline rental business is technically B2B, and my customer demographics are segmented by Events such as Weddings/Bar Mitzvahs/Graduations, Music Festivals, and Touring Artists who can't travel or fly with all their gear. Each type of customer has different needs, and understanding customer segments helps me anticipate and meet them.

Psychographic

Demographics alone aren't enough to understand how, when, and why people make purchasing decisions, and that's where psychographics come in.

These factors relate to the attitudes and psychological makeup of a customer and may include: Lifestyle, Goal, Pains, Habits, Values, Interests etc.

Behavioral

While psychographics relate to psychological attributes, behavioral segments look at how that's manifested in action.

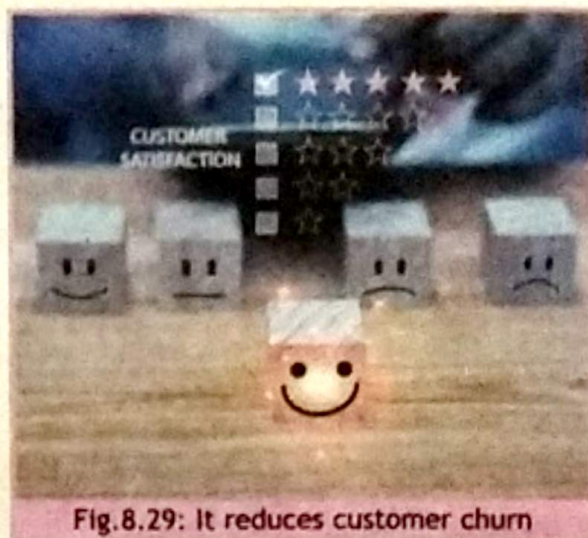

Fig.8.29: It reduces customer churn

You may consider segmenting by:

Engagement, Readiness to buy, Purchasing history, Product usage, Satisfaction, Loyalty or account age, Attention required etc.

Segments based on behavioral traits are some of the most valuable in customer support. It can help service teams find insights about customer interaction and how these trends manifest into recurring revenue and satisfaction rates.

And once those things are measured, they can be improved.

Geographic

Geographical factors are relevant when location affects how customers interact with a brand or receive their products.

Here are popular ways to segment based on geography:

City, Area, Region, Country etc.

Gaining insights based on geography can help your organization think through logistics, support implementation, and marketing.

The relevance of Geographical data varies depending on the type of business you run. In my experience running a music backline rental company, geographic data is hugely relevant because I can only serve customers within a certain radius of where my gear is located.

However, if you run a software business or sell products online, geographical data has a different level of relevance. Regardless, knowing where your customers are is helpful in understanding more about them and their needs.

Once you have this data, you can profile customers based on specific types or "segments."

Segments help you unearth trends in satisfaction, churn, and lifetime value that help you understand more about your ideal customer profiles.

8.6 Business Pitching: Identifying Problems and Creating Solutions

Introduction:

In today's fast-paced and competitive business environment, the ability to effectively pitch a business idea is crucial. Whether you are an aspiring entrepreneur seeking investment or a professional aiming to present a project to stakeholders, mastering the art of the pitch is essential. This document outlines a standard for students to learn how to identify problems and create and present business solutions, focusing on understanding the components of a successful business pitch and elevator pitch, and distinguishing between a business plan and a pitch document.

For example, "Hello, I'm Omalma, the founder of FirGrow, a startup dedicated to enhancing financial literacy through engaging seminars and webinars." This sets the stage and gives a quick

insight into who you are and what your business is about, establishing a connection with your audience from the outset.

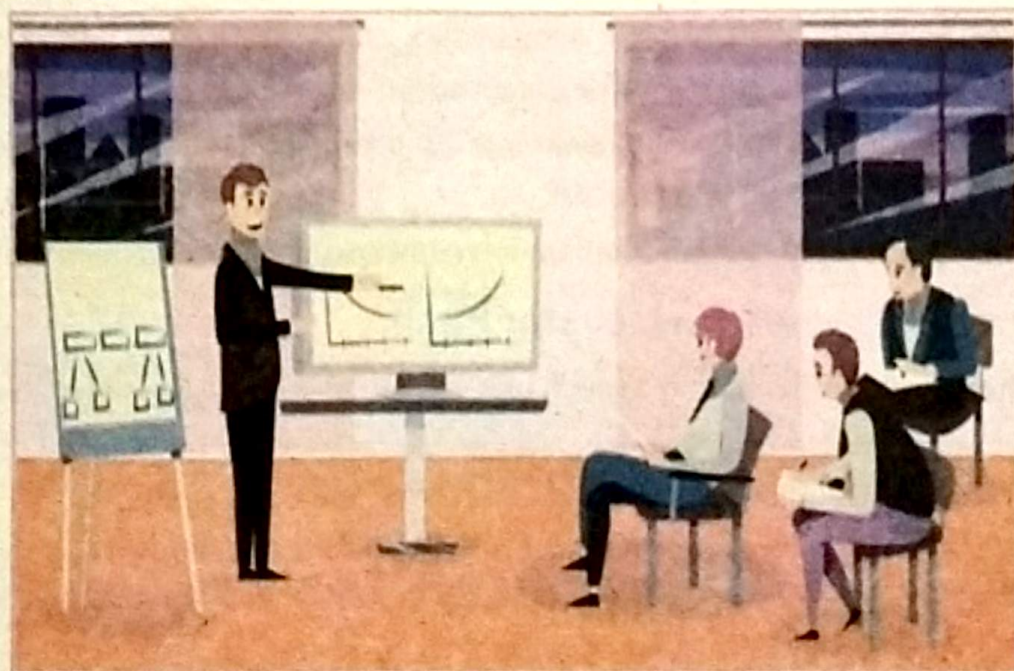

Fig.8.30: Identifying Problems and Creating Solutions

Components of a Successful Business Pitch:

A successful business pitch conveys the value of your idea clearly and concisely, capturing the interest of investors or stakeholders. Key components include:

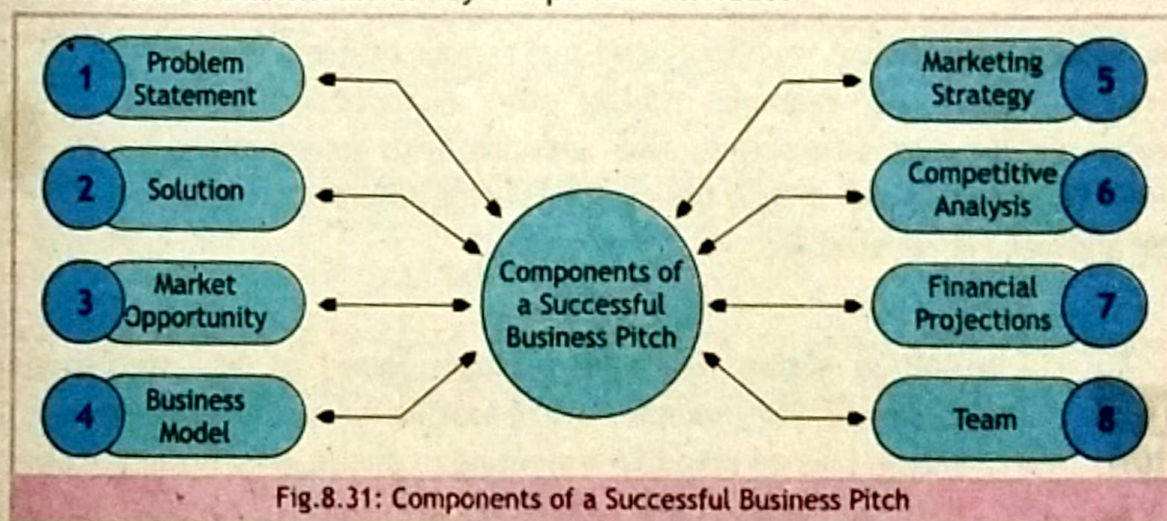

Fig.8.31: Components of a Successful Business Pitch

- **Problem Statement:** Clearly define the problem your business aims to solve. This helps your audience understand the relevance of your business.
- **Solution:** Describe your product or service and how it solves the problem. This is your chance to showcase your innovation.
- **Market Opportunity:** Explain the market size and potential for growth. This shows investors the business potential.
- **Business Model:** Explain how your business will make money. Describe how your business makes money. This is crucial for demonstrating sustainability.

- **Marketing Strategy:** Outline how you plan to attract and retain customers. This shows your approach to growth.
- **Competitive Analysis:** Identify your competitors and explain what makes your business unique. This highlights your competitive advantage.
- **Financial Projections:** Provide an overview of your expected revenue, expenses, and profitability. This gives a financial forecast.
- **Team:** Introduce key team members and their qualifications. This builds credibility and trust.

Components of a Successful Elevator Pitch:

An elevator pitch is a brief, persuasive speech that you use to spark interest in your idea.

- **Hook:** Start with an attention-grabbing statement or question to pique interest. For example, "Did you know that 3 out of 5 adults struggle with managing their finances?" A compelling hook immediately engages your audience and sets the tone for the rest of your pitch, making them want to hear more.

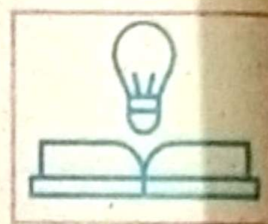

- **Brief Introduction:** Introduce yourself and your business in a concise manner. This quick introduction provides context and lets your audience know who you are and what you represent without taking too much time.

- **Unique Selling Proposition:** Highlight what makes your business unique compared to others. For example, "Unlike other financial education programs, we provide interactive, live sessions with personalized coaching." Emphasizing your unique selling points helps differentiate your business and make it memorable.

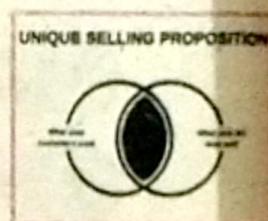

- **Call to Action:** End with a clear request or next step to guide your audience. For example, "We're looking for partners to help us expand our reach. Can we schedule a meeting to discuss this further?" A direct call to action provides a clear path forward, making it easier for your audience to respond positively to your pitch.

Difference Between a Business Plan and a Pitch Document

While both a business plan and a pitch document aim to convey the viability of a business, they serve different purposes:

Business Plan: A comprehensive document that details the business strategy, market analysis, financial projections, and operational plan. It is typically lengthy and used for internal planning and detailed investor reviews.

Pitch Document: A concise presentation, often in slide format, designed to quickly convey the

key aspects of the business to potential investors or stakeholders. It is shorter, more visual, and focuses on high-impact information.

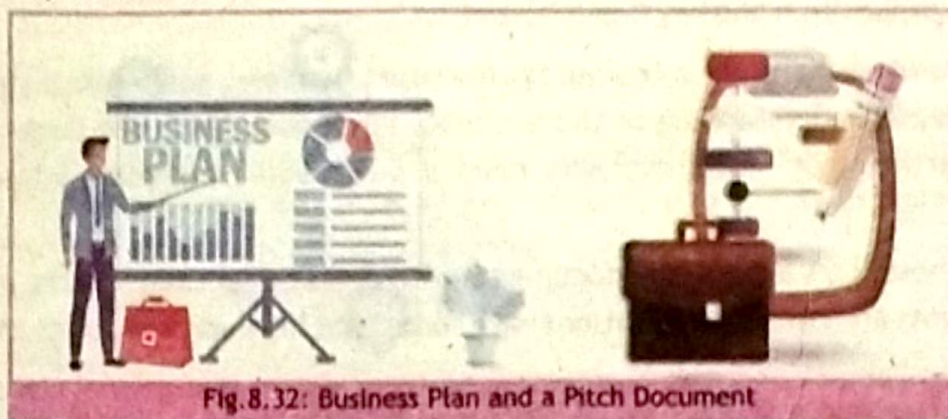

Fig. 8.32: Business Plan and a Pitch Document

Effective Communication Skills to Articulate a Business Idea

- ▶ **Clarity:** Communicate your ideas clearly and concisely to avoid misunderstandings. This is especially important when discussing complex topics, as it makes your ideas accessible to everyone.
- ▶ **Confidence:** Speak with confidence to convey credibility and persuade your audience. Confidence can be contagious and help build trust with your audience.
- ▶ **Engagement:** Keep your audience engaged with compelling stories and examples. Engaging your audience helps maintain their attention and makes your message more impactful.
- ▶ **Active Listening:** Listen to feedback and questions from your audience to address their concerns. Active listening helps build rapport and can provide valuable insights for improving your pitch.
- ▶ **Body Language:** Use positive body language to reinforce your message and convey confidence. Non-verbal cues are a powerful part of communication and can significantly influence how your message is received.
- ▶ **Adaptability:** Be prepared to adjust your pitch based on your audience's reactions. Being adaptable shows that you are attentive and capable of responding to different situations effectively.
- ▶ **Storytelling:** Use storytelling to make your pitch more relatable and memorable. Stories are a powerful way to illustrate your points and make your message more engaging and impactful.

Difference Between a Business Plan and a Pitch Document

- ▶ **Purpose:** A business plan is a comprehensive document that outlines the details of your business, including goals, strategies, and financial projections. In contrast, a pitch document is a concise and persuasive presentation designed to attract interest and secure a meeting or investment.
- ▶ **Length:** Business plans are typically 20-40 pages long, with detailed sections on various aspects of the business. Pitch documents, on the other hand, are usually 10-15 slides or 2-3 pages, focusing on the most critical points.

- **Detail:** Business plans include detailed market research, financial projections, and comprehensive strategies. Pitch documents provide a high-level overview, emphasizing the unique value proposition and key financial metrics.
- **Audience:** Business plans are intended for investors, lenders, and internal stakeholders who need an in-depth understanding of the business. Pitch documents are targeted at potential investors, partners, or customers who need a quick and compelling introduction to the business.
- **Format:** Business plans are written documents with detailed sections, charts, and appendices. Pitch documents are visual presentations with slides that highlight key points and data.
- **Focus:** Business plans cover the business's long-term vision, operational plans, and financial details. Pitch documents focus on the problem, solution, market opportunity, and the ask (e.g., investment or partnership).

Case Study

Startup Journey: Turning a Hobby into a Business

Ayesha, a young and enterprising individual, has successfully transformed her passion for baking into a thriving business. Her journey exemplifies the power of digital marketing and sustainable practices in modern entrepreneurship. Ayesha recognized the potential of the digital age and employed several strategies to grow her business:

Social Media Mastery:

She consistently shared visually appealing posts of her baked goods on Instagram and Facebook, using relevant hashtags to reach a wider audience. Ayesha ran contests and giveaways to encourage user engagement and generate buzz. She collaborated with local food bloggers and influencers to promote her products to their followers.

E-commerce Platform:

Ayesha created an online store to sell her products directly to customers, offering a convenient shopping experience. She integrated secure payment gateways to facilitate online transactions. She partnered with a reliable delivery service to ensure timely delivery of orders.

Marketing:

Ayesha optimized her website and social media content with relevant keywords to improve search engine visibility. She started a blog to share baking tips, recipes, and behind-the-scenes stories, attracting organic traffic.

Ayesha's commitment to sustainability has further enhanced her brand image:

- She prioritized sourcing ingredients from local farmers and suppliers to support the community and reduce carbon footprint.
- She used eco-friendly packaging materials, such as biodegradable containers and recyclable paper bags.
- Ayesha implemented strategies to minimize food waste, including composting and donating excess products to local charities.

Despite her success, Ayesha faced challenges:

- The bakery industry is competitive, but Ayesha differentiated herself by offering unique flavors and personalized services.
- She ensured consistent quality while scaling the business required careful planning and efficient operations.
- Ayesha learned to prioritize tasks, delegate responsibilities, and maintain a healthy work-life balance.

Unit Summary

- **Research:** A systematic process to discover, interpret, or revise facts. It includes identifying a problem, gathering data, analyzing it, and drawing conclusions.
- **Qualitative Research:** Research expressed in words to understand concepts or experiences. Uses interviews, observations, and literature reviews.
- **Quantitative Research:** Research based on numbers, using statistical analysis. Methods include surveys, experiments, and observations.
- **Data Collection Methods:** Various methods, such as surveys and interviews, collect data as numbers (quantitative) or words (qualitative).
- **Closed-Ended Questions:** Questions offering fixed responses, useful for collecting categorical or numerical data.
- **Open-Ended Questions:** Questions allowing broader answers, useful for understanding opinions but requiring more effort to analyze.
- **Analyzing Quantitative Data:** Uses statistical tools to find patterns and report results with graphs or tables.
- **Analyzing Qualitative Data:** Involves identifying themes in text or visual data. Methods include content or discourse analysis.
- **Market Validation:** A process to test a product's market need by collecting feedback or conducting surveys.
- **Business Pitch:** A brief presentation showcasing a business idea, including its problem, solution, market, and financial model.
- **Effective Communication Skills:** Clarity, active listening, and positive body language are essential for delivering a successful business pitch.
- **Research bias:** Systematic errors that can distort findings, such as information bias, sampling bias, or omitted variable bias.
- **Survey:** A research tool involving questions distributed to a sample to collect quantitative or qualitative data.
- **Sampling bias:** A type of bias where the sample does not represent the population being studied.
- **Ethnography:** A qualitative research method where researchers immerse themselves in a community to observe behaviors and culture.
- **Open-ended questions:** Questions that allow respondents to provide detailed, unrestricted answers.
- **Closed-ended questions:** Questions that offer a fixed set of responses for participants to choose from.

- **Likert scale:** A survey tool where participants rate their level of agreement or satisfaction on a scale.
- **Market validation:** The process of evaluating a product's feasibility and demand in the target market.
- **Nominal variable:** A categorical variable without a specific order, such as ethnicity or gender.
- **Ordinal variable:** A categorical variable with a clear order, like rankings (e.g., "satisfied" to "dissatisfied").
- **Quantitative analysis:** Analyzing numerical data to identify patterns, correlations, or causations.
- **Qualitative content analysis:** A method to identify themes or patterns in textual or visual data.
- **Discourse analysis:** Study of communication within social contexts to understand meanings and relationships.
- **Customer profiling:** Analyzing customer characteristics such as demographics, behavior, and preferences to understand their needs better.
- **Business pitch:** A concise presentation that outlines a business idea, problem, solution, and market opportunity.
- **Financial projections:** Estimated future financial performance, such as revenue or profit, used to assess business viability.
- **Active listening:** The practice of attentively listening to others to understand and respond effectively.
- **Body language:** Non-verbal communication through gestures, posture, and expressions to convey confidence and clarity.

Exercise

Q1. Select the best answer for the following MCQs.

1. What is the primary goal of quantitative research?
 - a) To understand concepts and experiences
 - b) To test or confirm theories and assumptions
 - c) To explore cultural and behavioral patterns
 - d) To gather in-depth insights on subjective topics
2. Which of the following is a common method in qualitative research?
 - a) Statistical analysis
 - b) Surveys with closed-ended questions
 - c) Thematic analysis
 - d) Experiments
3. In quantitative research, what type of data is typically used for statistical analysis?
 - a) Textual descriptions
 - b) Words and meanings
 - c) Numerical values
 - d) Visual images
4. Which method would you use if you want to understand how people feel about a new product?
 - a) A survey with Likert scale questions
 - b) A series of in-depth interviews
 - c) An experimental study
 - d) Observational data analysis
5. Which type of question is best suited for collecting detailed feedback and open-ended responses?
 - a) Closed-ended question
 - b) Likert scale question
 - c) Open-ended question
 - d) Binary question
6. What is a common problem with self-administered questionnaires?
 - a) High cost
 - b) High response rates
 - c) Nonresponse bias
 - d) Experimenter bias
7. Which method is typically used to ensure that the results of a questionnaire are not influenced by how questions are framed?
 - a) Using leading questions
 - b) Using double negatives
 - c) Balanced framing
 - d) Avoiding jargon

8. Which step in market validation involves estimating the potential market size and share for your product?

- a) Conducting customer validation interviews
- b) Writing down goals, assumptions, and hypotheses
- c) Testing your product or service
- d) Assessing market size and share

9. What type of data is useful for researching the search volume of related terms?

- a) Qualitative feedback from interviews
- b) Secondary data from market reports
- c) Monthly search volume data from search engines
- d) Customer demographic data

10. What information is typically included in a customer profile?

- a) Financial statements of the business
- b) Demographics, behaviors, and pain points of customers
- c) Market trends and competitive analysis
- d) Internal company processes

11. What is one benefit of creating customer profiles?

- a) Reduces the need for market research
- b) Decreases customer acquisition costs
- c) Eliminates the need for customer service
- d) Increases product complexity

12. What is the primary purpose of a business pitch?

- a) To provide a comprehensive analysis of the business strategy.
- b) To persuade investors or stakeholders of the business's potential and value.
- c) To detail the day-to-day operations of the business.
- d) To outline the long-term financial projections and market analysis.

13. Which component of a business pitch addresses how your business will make money?

- a) Problem Statement
- b) Solution
- c) Business Model
- d) Market Opportunity

14. In an elevator pitch, what is the primary purpose of the "hook"?
- a) To introduce the team members.
 - b) To provide detailed financial projections.
 - c) To grab the audience's attention and spark interest.
 - d) To explain the competitive analysis.
15. What is the main difference between a business plan and a pitch document?
- a) A business plan is more concise and visually appealing than a pitch document.
 - b) A pitch document includes detailed market research and financial projections.
 - c) A business plan is used for internal planning and detailed investor reviews, while a pitch document is designed for a quick, compelling introduction.
 - d) A business plan is shorter and less detailed than a pitch document.
16. Which of the following is NOT a key component of a successful elevator pitch?
- a) Unique Selling Proposition
 - b) Detailed Financial Projections
 - c) Brief Introduction
 - d) Call to Action
17. What should be the focus of a pitch document?
- a) Long-term operational plans
 - b) Detailed market research
 - c) High-impact information and key points to spark interest
 - d) Extensive financial data and projections
18. Which of the following best describes the term "Market Opportunity" in a business pitch?
- a) The financial model of the business
 - b) The potential market size and growth prospects for the business
 - c) The competitors in the industry
 - d) The unique features of the business's product or service

19. What role does "Active Listening" play in pitching a business idea?

- a) It helps to provide detailed financial data.
- b) It allows for better adaptation based on audience feedback.
- c) It focuses on presenting a detailed operational plan.
- d) It ensures that the pitch remains under 10 minutes.

20. Which of the following is an example of a call to action in an elevator pitch?

- a) "Our team has extensive experience in finance."
- b) "We project a revenue of \$500,000 in the first year."
- c) "Can we schedule a meeting to discuss potential investment opportunities?"
- d) "Our solution is unique compared to others."

Q2. Write answers of the following short response questions.

1. Explain how a mixed-methods approach combines qualitative and quantitative research.
2. List two potential biases in quantitative research and briefly describe their impact.
3. Identify the main difference between open-ended and closed-ended questions in a questionnaire?
4. Describe one advantage and one disadvantage of researcher-administered questionnaires.
5. Explain why alpha and beta testing are important in the product validation process.
6. How can customer validation interviews contribute to market validation?
7. What role do customer profiles play in marketing strategies?
8. Discuss how customer profiling can reduce customer churn.

Q3. Write answers of the following extended response questions.

1. What is research? Discuss the differences between quantitative and qualitative research.
2. What is market validation. Discuss how market validation is determined.
3. Discuss how customer profiles are created.
4. What is business pitching. Discuss the components of a successful business pitch.
5. Discuss the difference between a business plan and a pitch document.



Activity 3

Do research for your target market? For products similar to yours, research sales data, the number and share of current manufacturers, and what percentage of the total market your segment holds. Determine where your product fits into the market and assess how much of it your business could own.



Activity 4: Pitch Practice Session

Objective: To practice delivering a business pitch effectively.

Instructions:

Preparation: Choose a business idea or use a provided scenario. Prepare a pitch using the components discussed (Problem Statement, Solution, Market Opportunity, etc.).

Delivery: Deliver your pitch to a group of peers or mentors. Focus on clarity, confidence, and engagement.

Feedback: After the pitch, receive feedback from your audience on what worked well and what could be improved.

Revision: Revise your pitch based on the feedback and practice delivering it again.



Activity 5: Elevator Pitch Writing

Objective: To develop a concise and engaging elevator pitch.

Instructions:

Scenario: Imagine you have 60 seconds in an elevator with a potential investor. Write an elevator pitch that includes a hook, brief introduction, unique selling proposition, and call to action.

Peer Review: Share your pitch with a classmate or group for feedback on its effectiveness and clarity.

Refinement: Refine your pitch based on feedback and practice delivering it.



Activity 6: Comparative Analysis

Objective: To understand the differences between a business plan and a pitch document.

Instructions:

Research: Find examples of both a business plan and a pitch document online.

Comparison: Create a comparison table highlighting key differences in purpose, length, detail, audience, format, and focus.

Presentation: Present your findings to the class, explaining how each document serves its intended purpose.



Activity 7: Competitive Analysis Exercise

Objective: To identify and analyze competitors and define a unique selling proposition.

Instructions:

Research: Identify at least three competitors in a chosen industry or field.

Analysis: Analyze their strengths, weaknesses, and market positioning.

Unique Selling Proposition: Define what makes your business different and better than these competitors.

Presentation: Create a brief report or presentation summarizing your competitive analysis and unique selling proposition.



Activity 8: Financial Projection Workshop

Objective: To create basic financial projections for a business.

Instructions:

Scenario: Use a fictional business scenario or a real business idea you are familiar with.

Projection: Develop basic financial projections including expected revenue, expenses, and profitability for the first year.

Review: Compare your projections with classmates or a mentor to evaluate their realism and accuracy.



Activity 9: Storytelling Practice

Objective: To use storytelling to make a pitch more engaging.

Instructions:

Personal Story: Choose a personal story related to your business idea or a success story from your industry.

Integration: Integrate this story into your pitch to illustrate a key point or emotional connection.

Presentation: Share your pitch with the integrated story and receive feedback on how it impacted the overall message.



Activity 10: Problem Identification Brainstorming Session

Objective: To help students identify real-world problems that can be addressed through innovative business solutions.

Materials Needed:

Whiteboard or flip chart

Markers

Sticky notes

Timer

Instructions:

1. **Introduction (10 minutes):** Briefly explain the importance of identifying problems in the business world. Discuss examples of successful businesses that solved specific problems.
2. **Brainstorming (15 minutes):** Divide students into small groups. Give each group a set of sticky notes. Set a timer for 10 minutes and ask them to write down as many problems they can think of in their community or school (one problem per sticky note).
3. **Group Sharing (15 minutes):** After time is up, each group takes turns sharing their problems. Write the problems on the whiteboard, categorizing them (e.g., environmental issues, education gaps, health concerns).
4. **Reflection (10 minutes):** As a class, discuss which problems resonate most with them and why. Encourage students to think about potential business solutions for these problems.



Activity 11: Create a Business Pitch

Objective: To teach students how to structure and deliver a business pitch.

Materials Needed:

Pitch template handouts (including sections like Problem, Solution, Market Opportunity, etc.)

Access to research tools (books, internet, etc.)

Presentation tools (poster boards, markers, or digital presentation software)

Instructions:

1. **Introduction (10 minutes):** Explain the components of a successful business pitch, using examples from the provided material.
2. **Team Formation (5 minutes):** Divide students into small groups of 3-4.
3. **Pitch Development (30 minutes):** Each group selects one problem from the previous activity and creates a business pitch using the provided template. They should clearly define their problem, solution, market opportunity, business model, and marketing strategy.
4. **Presentation (20 minutes):** Each group presents their pitch to the class, aiming for 3-5 minutes each. Encourage students to use engaging storytelling techniques and positive body language.
5. **Feedback Session (10 minutes):** After each presentation, allow time for questions and constructive feedback from peers.



Activity 12: Elevator Pitch Challenge

Objective: To practice delivering a concise and impactful elevator pitch.

Materials Needed:

Timer

Evaluation criteria handouts (clarity, engagement, uniqueness, call to action)

Prize (optional, for motivation)

Instructions:

1. **Introduction (10 minutes):** Explain what an elevator pitch is and its importance in the business world. Share tips for creating an effective pitch.
2. **Pitch Preparation (15 minutes):** Each student chooses a business idea (either their own or one from the previous activities) and prepares a 30-second elevator pitch.
3. **Pitching Round (20 minutes):** Students take turns delivering their elevator pitches in front of the class. Use a timer to keep each pitch to 30 seconds.
4. **Peer Evaluation (10 minutes):** After all pitches are delivered, students use the evaluation criteria to provide feedback on their peers' pitches.
5. **Reflection and Discussion (10 minutes):** Conclude with a discussion on what makes a pitch effective and how students can improve. Optionally, recognize the best pitch with a small prize to encourage participation.

Annexure 1

ASCII Non-Printing Control Codes Chart

Decimal	Hex	Oct	Abbr.	Description	Decimal	Hex	Oct	Abbr.	Description
0	0	000	NUL	null	16	10	020	DLE	data link escape
1	1	001	SOH	start of heading	17	11	021	DC1	device control 1
2	2	002	STX	start of text	18	12	022	DC2	device control 2
3	3	003	ETX	end of text	19	13	023	DC3	device control 3
4	4	004	EOT	end of transmission	20	14	024	DC4	device control 4
5	5	005	ENQ	inquiry	21	15	025	NAK	negative acknowledge
6	6	006	ACK	acknowledge	22	16	026	SYN	synchronous idle
7	7	007	BEL	bell	23	17	027	ETB	end of transmission block
8	8	010	BS	backspace	24	18	030	CAN	cancel
9	9	011	TAB	horizontal tab	25	19	031	EM	end of medium
10	A	012	LF	line feed/new line	26	1A	032	SUB	substitute
11	B	013	VT	vertical tab	27	1B	033	ESC	escape
12	C	014	FF	form feed/new page	28	1C	034	FS	file separator
13	D	015	CR	carriage return	29	1D	035	GS	group separator
14	E	016	SO	shift out	30	1E	036	RS	record separator
15	F	017	SI	shift in	31	1F	037	US	unit separator

Annexure 2

Extended ASCII Printing Characters Chart (character codes 128-255)

This has many variations - below is the Microsoft variation and is called ANSI or Windows-

Decimal	Character	Decimal	Character	Decimal	Character	Decimal	Character
128	€	160		192	À	224	à
129		161	¡	193	Á	225	á
130	,	162	¢	194	Â	226	â
131	f	163	£	195	Ã	227	ã
132	"	164	¤	196	Ä	228	ä
133	...	165	¥	197	Å	229	å
134	†	166		198	Æ	230	æ
135	‡	167	§	199	Ç	231	ç
136	^	168	"	200	È	232	è
137	‰	169	©	201	É	233	é
138	Š	170	ª	202	Ê	234	ê
139	‹	171	«	203	Ë	235	ë
140	Œ	172	¬	204	Ì	236	ì
141		173	-	205	Í	237	í
142	Ž	174	®	206	Î	238	î
143		175	¯	207	Ï	239	ï
144		176	°	208	Ð	240	ð
145	´	177	±	209	Ñ	241	ñ
146	ˆ	178	²	210	Ò	242	ò
147	"	179	³	211	Ó	243	ó
148	"	180	´	212	Ô	244	ô
149	•	181	µ	213	Õ	245	õ
150	—	182	¶	214	Ö	246	ö
151	—	183	·	215	×	247	+
152	~	184	,	216	Ø	248	ø
153	™	185	í	217	Ù	249	ù
154	š	186	º	218	Ú	250	ú
155	›	187	»	219	Û	251	û
156	œ	188	¼	220	Ü	252	ü
157		189	½	221	Ý	253	ý
158	ž	190	¾	222	Þ	254	þ
159	ÿ	191	¿	223	ß	255	ÿ

Annexure 3

ASCII Printing Characters Chart

Decimal	Hex	Oct	Character	Decimal	Hex	Oct	Character	Decimal	Hex	Oct	Character
32	20	040	space	64	40	100	@	96	60	140	,
33	21	041	!	65	41	101	A	97	61	141	a
34	22	042	"	66	42	102	B	98	62	142	b
35	23	043	#	67	43	103	C	99	63	143	c
36	24	044	\$	68	44	104	D	100	64	144	d
37	25	045	%	69	45	105	E	101	65	145	e
38	26	046	&	70	46	106	F	102	66	146	f
39	27	047	'	71	47	107	G	103	67	147	g
40	28	050	(72	48	110	H	104	68	150	h
41	29	051)	73	49	111	I	105	69	151	i
42	2A	052	*	74	4A	112	J	106	6A	152	j
43	2B	053	+	75	4B	113	K	107	6B	153	k
44	2C	054	,	76	4C	114	L	108	6C	154	l
45	2D	055	-	77	4D	115	M	109	6D	155	m
46	2E	056	.	78	4E	116	N	110	6E	156	n
47	2F	057	/	79	4F	117	O	111	6F	157	o
48	30	060	0	80	50	120	P	112	70	160	p
49	31	061	1	81	51	121	Q	113	71	161	q
50	32	062	2	82	52	122	R	114	72	162	r
51	33	063	3	83	53	123	S	115	73	163	s
52	34	064	4	84	54	124	T	116	74	164	t
53	35	065	5	85	55	125	U	117	75	165	u
54	36	066	6	86	56	126	V	118	76	166	v
55	37	067	7	87	57	127	W	119	77	167	w
56	38	070	8	88	58	130	X	120	78	170	x
57	39	071	9	89	59	131	Y	121	79	171	y
58	3A	072	:	90	5A	132	Z	122	7A	172	z
59	3B	073	;	91	5B	133	[123	7B	173	{
60	3C	074	<	92	5C	134	\	124	7C	174	
61	3D	075	=	93	5D	135]	125	7D	175	}
62	3E	076	>	94	5E	136	^	126	7E	176	~
63	3F	077	?	95	5F	137	_	127	7F	177	DEL

Annexure 4

256: Å	512: Ä	768: Ɔ	1024: É	1280: d	1536: 𑂀	1792: 𑂀
257: å	513: ä	769: Ɔ	1025: Ê	1281: d	1537: 𑂀	:1793
258: Å	514: Ä	770: Ɔ	1026: Ğ	1282: du	1538: 𑂀	:1794
259: å	515: ä	771: Ɔ	1027: Ğ	1283: du	1539: 𑂀	:1795
260: A	516: Ê	772: Ɔ	1028: Ğ	1284: Ɔ	1540: 𑂀	:1796
261: a	517: ê	773: Ɔ	1029: S	1285: Ɔ	𑂀:1541	:1797
262: C	518: Ê	774: Ɔ	1030: I	1286: Ɔ	𑂀:1542	:1798
263: c	519: ê	775: Ɔ	1031: Ī	1287: Ɔ	𑂀:1543	:1799
264: Ć	520: Ī	776: Ɔ	1032: J	1288: Ĭ	𑂀:1544	:1800
265: ċ	521: ĩ	777: Ɔ	1033: Ĭ	1289: Ĭ	𑂀:1545	:1801
266: Ć	522: Ī	778: Ɔ	1034: Ĭ	1290: Ĭ	𑂀:1546	:1802
267: c	523: ĩ	779: Ɔ	1035: Ĭ	1291: Ĭ	𑂀:1547	:1803
268: Ć	524: Ō	780: Ɔ	1036: Ĭ	1292: Ĭ	:1548	:1804
269: ċ	525: ō	781: Ɔ	1037: Ĭ	1293: Ĭ	𑂀:1549	:1805
270: Đ	526: Ō	782: Ɔ	1038: Ÿ	1294: Đ	𑂀:1550	:1806
271: đ	527: ô	783: Ɔ	1039: Ÿ	1295: Đ	𑂀:1551	:1807
272: Đ	528: Ŕ	784: Ɔ	1040: A	1296: E	𑂀:1552	:1808
273: đ	529: ŕ	785: Ɔ	1041: B	1297: E	𑂀:1553	:1809
274: Ê	530: Ŕ	786: Ɔ	1042: B	1298: Ĳ	𑂀:1554	:1810
275: ê	531: ŕ	787: Ɔ	1043: Ğ	1299: Ĳ	𑂀:1555	:1811
276: Ê	532: Ū	788: Ɔ	1044: D	1300: Ĳ	𑂀:1556	:1812
277: ê	533: ū	789: Ɔ	1045: E	1301: Ĳ	:1557	:1813
278: Ê	534: Ū	790: Ɔ	1046: Ж	1302: Ĳ	𑂀:1558	:1814
279: e	535: ū	791: Ɔ	1047: 3	1303: Ĳ	𑂀:1559	:1815
280: E	536: S	792: Ɔ	1048: И	1304: Ɔ	𑂀:1560	:1816
281: e	537: s	793: Ɔ	1049: Ĭ	1305: Ɔ	𑂀:1561	:1817
282: Ê	538: T	794: Ɔ	1050: K	1306: Q	𑂀:1562	:1818
283: ê	539: t	795: Ɔ	1051: Л	1307: q	:1563	:1819
284: Ğ	540: 3	796: Ɔ	1052: M	1308: W	𑂀:1564	:1820
285: ğ	541: 3	797: Ɔ	1053: H	1309: w	𑂀:1565	:1821
286: Ğ	542: H	798: Ɔ	1054: O	1310: K	𑂀:1566	:1822
287: ğ	543: h	799: Ɔ	1055: П	1311: k	𑂀:1567	:1823
288: G	544: Ŋ	800: Ɔ	1056: P	1312: Ĭ	𑂀:1568	:1824
289: g	545: g	801: Ɔ	1057: C	1313: Ĭ	:1569	
290: G	546: 8	802: Ɔ	1058: T	1314: H	:1570	

Glossary

Access Control	Policies and mechanisms that restrict access to resources based on user roles and permissions.
Algorithm	A well-defined, step-by-step procedure or set of rules for solving a specific problem or performing a task.
Binary Arithmetic	Computers perform addition, subtraction, multiplication, and division in binary.
Blockchain	A digital ledger or database of transactions that continuously grows. It is created, maintained and shared by network users.
Churn Prediction	The technique to find out the possibility of a customer, to stop taking the services or products of a certain company. It is used in the fields of business and marketing.
Cloud computing	The delivery of computing services such as servers, storage, database, networking and application software over the cloud (Internet).
Collaboration	The use of digital devices involves networking and collaboration with other people across distances.
Combination	A selection of items from a set where the order of selection does not matter.
Computer vision	It is a specialized branch of AI that teaches computers to draw meaningful results from digital images, videos and other visuals.
Computing problem	In computer science is one that is solved step-by-step through computation.
Computational Thinking	A way of solving problems by using ideas from computer science.
Cookies	Small text files stored on a user's device to track online activity, which can raise privacy concerns.
Cybersecurity	The practice of protecting computer systems, networks, and data from unauthorized access, cyberattacks, and other malicious activities.
Cryptocurrency	A digital (or virtual) currency that facilitates direct payment without the involvement of intermediaries such as bank.
Cyberbullying	Online harassment or bullying that can cause emotional distress and has significant negative impacts on individuals.
Database	A collection of related data stored in the form of tables.

Data Cleaning	Is about fixing the data to make sure it's ready for analysis.
Data Encryption	The process of converting data into a coded format to prevent unauthorized access.
Data Modeling	A structure that represents the data and how different parts relate to each other.
Debugging	IDEs provide tools for finding and fixing bugs by stepping through code.
Digital literacy	It is the ability to create information in a digital environment.
Digital Search/Information Literacy	It is the ability to collect, understand and evaluate information from various sources.
IoT	An infrastructure that consists of network of servers that provides connectivity between multiple devices and facilitates man to machine and machine to machine interaction.
Natural Language Processing (NLP)	A branch of Artificial Intelligence which gives computers the ability to understand text and spoken words the same way humans do.
Permutation	An arrangement of all the members of a set into a specific sequence or order.
Podcast	It is a series of audio or video files that are released on a regular schedule.
Robotics	A combination of artificial intelligence and engineering which involves designing, creation and operation of automated machine programmed to perform tasks like humans.
Searching	The process of finding a particular item within a set.
Sorting	The process of arranging items in a specific order.
Spam	Unwanted and often malicious emails that compromise user privacy and security.
Spyware	Malicious software that secretly monitors and collects personal information from users.
VPN (Virtual Private Network)	A service that encrypts internet connections, enhancing privacy and security.

Content Authors

Dr. Saleem Iqbal received both his BS and MS in Computer Science from the COMSATS, Pakistan and PhD from UTM, Malaysia in 2015. He has a diversified experience of over 18 years comprising academic, development, research and administrative. Currently, he is an Associate Professor and Chairman of Computer Science Department at Allama Iqbal Open University. Previously he was with PMAS-Arid Agriculture University Rawalpindi and COMSATS, Islamabad.



Mohammad Khalid, a luminary in the field of Computer Science and Assistant Professor at OPF Boys College. Professor Khalid's rich pedigree, boasting an M.Sc. in Computer Science and B.Ed. qualifications, infuses every page of these meticulously crafted textbooks for Grades IX to XII. Collaborating with the prestigious National Book Foundation (NBF), Professor Khalid's work epitomizes innovation, excellence, and pedagogical mastery. Dive into a realm of unparalleled insight, where theoretical depth converges with practical application, propelling students towards digital fluency and technological prowess.



Dr. Faraz Ahsan is an Educational and IT Specialist with more than 20 years of experience of both academia and industry. He worked as a Software Engineer and Network Administrator in the industry. Later, he completed his PhD from COMSATS Institute of Information Technology and specialized in the field of Network Security. He is currently associated as Consultant with a USA based firm.



Lubna Kousar Janjua is an educationist and IT professional, with more than 20 years of experience. She received her MCS degree from IIUI and completed MS coursework from NUST with a specialization in Intelligent Information System. She worked as a software engineer for a multinational company and is currently serving as a Computer Science professor.



Mohammad Sajjad Heder has done Master (MS) in Computer Science from George Mason University, Virginia, USA and B.E. Mechanical Engineering from Kim Chaek University of Technology, Korea. He has 25 years' experience of teaching the subject of Computer Science to students of SSC and HSSC. He has written 8 textbooks of Computer Science for grades 9 to 12.



Shah Islam Khan, a distinguished author renowned for his groundbreaking 'IQ Series' books. His academic journey boasts a breadth of qualifications, from an MPhil in Higher Education to a range of degrees including BS(CS), DIT, MEd, and BEd. His diverse expertise enriches his literary contributions, promising readers a depth of knowledge and insight unparalleled in his field. Prof Shah Islam has been working in OPF BOYS COLLEGE ISLAMABAD for the last twenty years.



Dr. Mian Hamid Hassan is an Educational Specialist with more than 19 years of diversified experience in the field of Education specially teachers training and education. He did Masters in Technology Education from University of the Punjab with distinction and was awarded University Grants Commission's research scholarship for Ph.D. studies. Dr. Hassan is working as an Associate Professor at Federal College of Education and is involved in Teachers Training (In/ Pre - Service) especially in the Field of Technical, Elementary, Secondary and Science education.



Approved by National Curriculum Council, Secretariat
Ministry of Federal Education & Professional Training
vide letter No. F.No.1-2/2024/NBF-CS, Dated: December 09, 2024

پاک سر زمین شاد باد! کشورِ حسین شاد باد!
تو نشانِ عزمِ عالی شان ارضِ پاکستان
مركزِ یقین شاد باد!

پاک سر زمین کا نظام قوتِ اخوتِ عوام
قوم، ملک، سلطنت پائندہ تابندہ باد!
شاد باد منزلِ مسراد!

پرچمِ ستارہ و ہلال رہبرِ ترقی و کمال
ترجمانِ ماضی، شانِ حال جانِ استقبال
مایہ خدائے ذوالجلال!



National Book Foundation
as
Federal Textbook Board
Islamabad

