

بِسْمِ اللَّهِ الرَّحْمَنِ الرَّحِيمِ

(In the Name of Allah, the Most Merciful, the Most Compassionate.)

CHEMISTRY

12



**PUNJAB EDUCATION, CURRICULUM,
TRAINING AND ASSESSMENT AUTHORITY**

This textbook is based on updated / Revised National Curriculum of Pakistan 2023 and has been approved by Punjab Education, Curriculum, Training and Assessment Authority (PECTAA).

All rights are reserved with PECTAA.

No part of this textbook can be copied, translated, reproduced or used for preparation of test papers, guidebooks, keynotes and helping books.

AUTHORS

- **Dr. Ch. Jamil Anwar**, Prof. Emeritus, University of Punjab, Lahore
- **Dr. Muhammad Monim-ul-Mehboob**, Prof. of Chemistry, Govt. Graduate College of Science Wahdat Road, Lahore
- **Dr. Bushra Maliha**, A levels teacher & trainer, BCP liberty Campus, Lahore & LGS, 55 main, Gulberg Lahore
- **Dr. Abid Zia** Prof. of Chemistry (Rtd.) Govt. College of Science Wahdat Road, Lahore
- **Dr. Saman Jamil**, (Rtd.) SSS, PCTB
- **Tafazzal Hussain Bhutta**, SSS, DPS and Inter College, Lahore
- **Ms. Samina Gull**, Chemistry Coordinator, PECTAA

REVIEWERS

- **Dr. Iftikhar Hussain**, Associate Professor, Govt. Graduate College of Science, Wahdat Road, Lahore
- **Dr. Rubina Munir**, Assistant Professor, Head of the Department of Chemistry, Kinnaird College for Women, Lahore
- **Dr. Imtiaz Hussain**, Principal (Rtd.), Govt. Graduate College Sumandari, District Faisalabad.
- **Dr. Tariq Mehmood**, Assistant Professor, Govt. Graduate College of Science Wahdat Road, Lahore
- **Imran Shakoor**, International A Level Examiner, Head of the Department of Chemistry Myer's College Chakwal

CONSULTANT

- **Ms. Muzamal Tehzeeb**, M. Phil (Applied Chemistry), UET Lahore

EDITOR

- **Dr. Azmat Mehmood Asim**, Associate Professor, Govt. Islamia Associate College (B) Lahore Cantt.

Director (Curriculum & Compliance)

○ Mr. Aamir Riaz

Deputy Director (Compliance – Sciences)

○ Syed Saghir-ul-Hassnain Tirmizi

Coordinator

○ Ms. Samina Gull, AD (C-Sc.),

Incharge Art Cell

○ Ms. Aisha Sadiq

Composing and layout Designing

○ Mr. Tahir Sarfraz Butt

Illustrator

○ Mr. Tahir Sarfraz Butt

**Edition
Experimental**

Date of Printing	Edition	Impression	Copies	Price

Contents

UNIT 17 Page No
1 - 13
GROUP 2 ELEMENTS

UNIT 18 Page No
14 - 34
TRANSITION METALS

UNIT 19 Page No
35 - 55
BASICS OF ORGANIC CHEMISTRY

UNIT 20 Page No
56 - 71
AROMATIC HYDROCARBONS

UNIT 21 Page No
72 - 84
HALOGENOALKANES

UNIT 22 Page No
85 - 97
HYDROXY COMPOUNDS

UNIT 23 Page No
98 - 114
**CARBONYL COMPOUNDS AND
CARBOXYLIC ACIDS**

UNIT 24 Page No
115 - 130
ORGANIC NITROGEN COMPOUNDS

UNIT 25 Page No
131 - 141
ORGANIC SYNTHESIS

UNIT 26 Page No
142 - 156
POLYMERS

UNIT 27 Page No
157 - 174
BIOCHEMISTRY

UNIT 28 Page No
175 - 182
CHROMATOGRAPHY

UNIT 29 Page No
183 - 198
SPECTROSCOPY-1

UNIT 30 Page No
199 - 213
SPECTROSCOPY-2 NMR

UNIT 31 Page No
214 - 228
MATERIALS AND ENERGY

UNIT 32 Page No
229 - 243
**MEDICINE, AGRICULTURE
AND INDUSTRY**

UNIT 33 Page No
244 - 258
WATER

17

GROUP 2
ELEMENTS

Student Learning Outcomes

[C-12- B-01 to C-12-B-15]

- ⊙ Describe the properties and trends of Group 2 elements, including their electron configurations, reactivity, and common compounds such as oxides, hydroxides and carbonates.
- ⊙ Explain the reactivity of Group 2 elements in terms of their electron configuration and valence electrons.
- ⊙ Explain the chemical reactivity of Group 2 elements, including their reactions with oxygen, water, and acids (Be, Mg, Ca).
- ⊙ Explain the term reactivity series and its application in predicting the outcome of chemical reactions.
- ⊙ Explain the term basic oxide and its application in the formation of Group 2 compounds.
- ⊙ Compare the properties and reactivity of Group 2 elements with group 1 in the periodic table.
- ⊙ Understand the term thermal decomposition and its application in the analysis of Group 2 compounds especially carbonates and nitrates.
- ⊙ Use the term thermal decomposition and its application in the analysis of Group 2 compounds especially carbonates and nitrates.
- ⊙ Describe qualitatively the trend in the thermal stability of the nitrates and carbonates including the effect of ionic radius on the polarization of the large anion.
- ⊙ Explain the trend in solubility of group 2 sulphates and hydroxides using terms enthalpy of hydration and enthalpy of solution.
- ⊙ Describe qualitatively the variation in solubility and of enthalpy change of solution, ΔH_{sol} , of the hydroxides and sulphates in terms of relative magnitudes of the enthalpy change of hydration and the lattice energy"
- ⊙ Explain the term complex ion and its application in the formation of Group 2 compounds.
- ⊙ Explain the extraction and purification process of Group II elements and their compounds.
- ⊙ Describe the industrial and everyday uses of Group 2 compounds, including their role in medicine and agriculture.

Group 2 elements are s block elements in Group 2 of the periodic table. They are also called the alkaline earth metals due to their metallic nature and occurrence in the earth crust. These elements present a class of metals having reactivity between highly reactive alkali metals and less reactive transition metals. Ca and Mg are among the eight most widely occurring elements in the earth crust.



Most firework colours are due to Group 2 element



Be is used to make copper alloys harder for aerospace materials, while Mg is an important part of chlorophyll, the green matter in plants. Mg, Ca, Sr, and Ba are essential components of fireworks due to their vibrant flame colours.

17.1 PROPERTIES AND TRENDS OF GROUP 2 ELEMENTS

All these elements have two electrons in their outermost 's' subshells (ns^2), therefore, they exhibit similar chemical properties. However, the properties of the elements vary from top to bottom in the group. Salient characteristics of Group 2 elements are given in **Table 17.1**. The trend in melting point and density are related to the different packing of the metal atoms down the group.

Table 17.1 Properties of Group 2 (Be–Ba)

Property	Beryllium (Be)	Magnesium (Mg)	Calcium (Ca)	Strontium (Sr)	Barium (Ba)
Atomic Number	4	12	20	38	56
Electron Configuration	[He] $2s^2$	[Ne] $3s^2$	[Ar] $4s^2$	[Kr] $5s^2$	[Xe] $6s^2$
Metallic Radius (pm)	112	160	197	215	222
Ionic Radius (M^{2+})	31	65	99	113	135
1 st Ionization Energy	900	738	590	550	503
2 nd Ionization Energy	1757	1451	1145	1064	965
Electronegativity	1.5	1.2	1.0	1.0	0.9
Melting Point ($^{\circ}C$)	1287	650	842	777	727
Density (g/cm^3)	1.85	1.74	1.54	2.64	3.51
Standard Electrode Potential (E°)	-1.97	-2.34	-2.87	-2.89	-2.91

17.1.1 Chemical reactivity of Group 2 Elements

The reactivity of Group 2 elements can be explained based on their electronic configuration. There are two electrons in their outermost subshells (ns^2). After losing these two electrons, they become stable ions with a +2 charge (M^{2+}). This makes them react quickly with other substances. The reactivity increases from Be to Ba due to the increase in size, shielding effect and decrease in the ionization energy down the group. This makes the removal of electrons easier, and the reactivity increases.



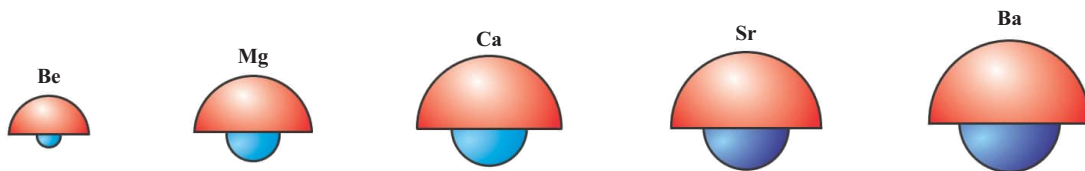


Figure 17.1: Relative sizes of the atoms of the Group 2 elements

Based on the above factors, the reactivity series can be presented in the increasing order from Be to Ba as given below. It shows that Be is the least reactive and Ba is the most reactive element of Group 2.



17.2 CHEMICAL REACTIONS OF GROUP 2 ELEMENTS

17.2.1 Reactions with Oxygen

All Group 2 metals burn in oxygen to form metal oxides (MO).



Beryllium (Be) reacts with oxygen at high temperatures (above 600 °C) to form (BeO). A thin, strong oxide layer usually protects it, making it less reactive than the other group members.



Magnesium (Mg) burns brightly in air or oxygen to form magnesium oxide (MgO). The reaction of calcium (Ca) with oxygen is more vigorous to give a brick red flame.

The oxides of the Group 2 elements are generally white solids and basic in nature and their basic character increases down the group. The basic character in water is due to the reaction between the oxide ion and water to produce the OH⁻ ion.

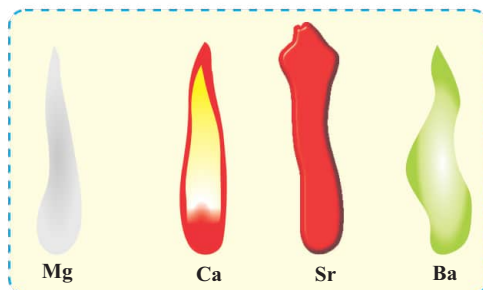
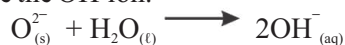
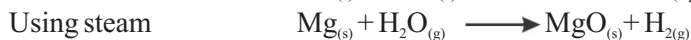


Figure 17.2: Flames of Group 2 elements

17.2.2 Reactions with Water

Except beryllium (Be), other Group 2 metals react with water to produce metal hydroxides, M(OH)₂ and hydrogen gas (H₂). Beryllium (Be) does not react with water or steam, even when heated. This is due to its protective oxide layer.

Magnesium (Mg) reacts very slowly with cold water, forming Mg(OH)₂ and H₂. With steam, it reacts faster to form magnesium oxide (MgO) and hydrogen.



Calcium (Ca) reacts with cold water and steam more vigorously than magnesium, forming Ca(OH)_2 and H_2 . The calcium hydroxide is sparingly soluble, forming a white precipitate.



The hydroxides of Group 2 are less basic than the Group 1 elements. However, the basic character of the hydroxides of Group 2 elements increases down the group due to the increasing solubility.

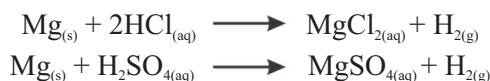
17.2.3 Reactions with Acids

Group 2 metals react with dilute acids to produce a salt and hydrogen gas (H_2).



Reactivity increases down the group. Beryllium (Be) reacts with dilute acids to form BeCl_2 and hydrogen gas, but its protective oxide layer can slow this reaction.

Magnesium (Mg) reacts readily with dilute acids (e.g., hydrochloric acid, sulphuric acid) to form magnesium salts and hydrogen gas.



Calcium (Ca) reacts vigorously with dilute acids to form calcium salts and hydrogen gas.



However, with sulphuric acid, the reaction can stop early because the calcium sulphate (CaSO_4) formed is sparingly soluble and coats the metal surface with a protective layer.



Figure 17.3 Calcium forms a sparingly soluble hydroxide with water



Quick Check

17.1


- Write equations for the following reactions:
 - Ca with oxygen
 - Ba with water
- Predict the extent of the reactions of Sr and Ba with H_2SO_4 .
- Explain why Group 2 elements are reactive, based on their electron configuration and ion formation.
- Write a balanced equation for calcium and barium burning in air and compare their reactivity.
- Predict the density and melting point of the radioactive radium (Ra) following the trend in Group 2.

17.3 COMPARISON OF GROUP 2 ELEMENTS WITH GROUP 1 ELEMENTS

Group 1 (alkali metals) and Group 2 (alkaline earth metals) both include highly reactive metals, but they show key differences due to the difference in their ionization energies. Group 1 metals have only one electron to lose, making them extremely eager to react and form a +1 ion.



Group 2 metals lose two electrons, which requires more energy, so they are reactive but generally less so than their Group 1 counterparts in the same period. Both groups show increasing reactivity going down their respective groups due to increasing atomic size, and decreasing ionization energy.

Table 17.2 Comparison of Group 2 elements with Group 1 elements

Feature	Group 1 (Alkali Metals)	Group 2 (Alkaline Earth Metals)
Valence Electrons	1 (ns^1)	2 (ns^2)
Ion Formation	Forms +1 ions (M^+)	Forms +2 ions (M^{2+})
Reactivity	More reactive	Less reactive (compared to Group 1 elements in the same period)
Reason for Reactivity	Low ionization energies	Higher ionization energies
Hardness	Very soft (can be cut with a knife).	Harder than Group 1 metals.
Density	Low densities.	Higher densities than Group 1 metals.
Melting/Boiling Points	Lower melting/boiling points.	Higher melting/boiling points.
Reaction with Water	Very vigorous, often explosive (e.g., Na with water).	Less vigorous (e.g., Ca with water, Mg with steam).
Oxides	Form M_2O (e.g., Na_2O); highly basic.	Form MO (e.g., CaO); less basic than Group 1 oxides.
Hydroxides	Highly soluble, strong bases.	Less soluble than Group 1, but solubility increases down the group. Less basic than Group 1 hydroxides

17.4 THERMAL DECOMPOSITION OF CARBONATES AND NITRATES

Thermal decomposition is a chemical reaction, where a single compound breaks down into two or more simpler substances when heated. This process usually requires energy (endothermic) to break the chemical bonds within the compound.



Thermal decomposition is very useful for understanding and analyzing Group 2 carbonates and nitrates because their thermal stability follows a clear trend down the group.

Group 2 carbonates decompose upon heating to form a metal oxide (MO) and carbon dioxide gas (CO₂). The thermal stability of carbonates increases down the group. This means that BeCO₃ decomposes at a lower temperature than MgCO₃, which decomposes at a lower temperature than CaCO₃, and so on.



BaCO₃ requires the highest temperature to decompose.

The above discussed trend is due to the size of the M²⁺ ion. Smaller and highly charged cations (like Be²⁺) have a greater "polarizing power." They distort the large carbonate ion (CO₃²⁻) to a larger extent, weakening its bonds and making it easier to decompose with heat. As the metal ion gets larger down the group, its polarizing power decreases, leading to more stable carbonates that require more heat for decomposition.

Group 2 nitrates decompose upon heating to form a metal oxide (MO), brown nitrogen dioxide gas (NO₂), and oxygen gas (O₂).



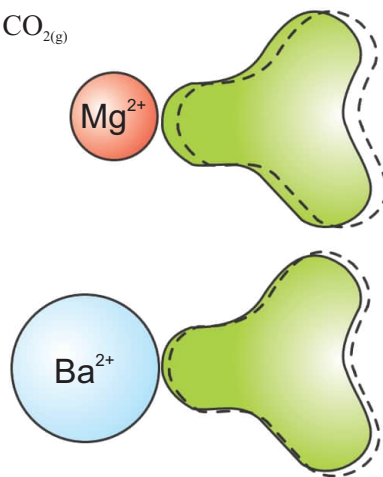
Similar to carbonates, the thermal stability of nitrates also increases down Group 2. Be(NO₃)₂ is the least stable, and Ba(NO₃)₂ is the most stable among them.

The same polarizing power argument applies here as well. The smaller M²⁺ ions at the top of the group distort the nitrate ion (NO₃⁻) more effectively, making its decomposition easier at lower temperatures.

By observing the temperature at which a Group 2 carbonates or nitrates decompose, chemists can identify the unknown compounds and confirm the presence of specific elements. The decomposition pattern helps to understand the relationship between ionic size, charge density, and thermal stability. The temperatures at which Group 2 carbonates decompose are given in **Table 17.3**

Table 17.3 Temperatures of decomposition of the Group 2 carbonates at 1 atm

Metal Carbonate	Temperature (°C)
BeCO ₃	250
MgCO ₃	540
CaCO ₃	900
SrCO ₃	1289
BaCO ₃	1360




Quick Check 17.2


- State two physical differences between Group 1 and Group 2 metals.
- State the general formula for a Group 1 oxide and a Group 2 oxide.
- Write the balanced equation for the thermal decomposition of SrCO_3 .
- Explain qualitatively why magnesium carbonate is thermally less stable than calcium carbonate.
- Write the equations for the thermal decomposition of
 - magnesium nitrate
 - Barium nitrate. Which of these decomposes at a lower temperature?

17.5 SOLUBILITY OF GROUP 2 SULPHATES AND HYDROXIDES

The solubility of an ionic compound in water depends on the balance between two main energy changes:

- Enthalpy of Hydration (ΔH_{hyd})** is the energy released when gaseous ions are surrounded and attracted by water molecules (becomes hydrated). This is always exothermic (negative value). Stronger attraction between ions and water molecules means a more negative ΔH_{hyd} . Smaller ions with higher charge density attract water molecules more strongly, leading to a more negative and higher hydration enthalpy. ΔH_{hyd} becomes *less negative* (less energy released) as you go down a group (ions get larger).
- Lattice Enthalpy ($\Delta H_{\text{lattice}}$)** is the energy required to break apart one mole of a solid ionic compound into its gaseous ions. This is always endothermic. Stronger forces in the crystal lattice imply a higher lattice enthalpy. It depends on the charges and sizes of the ions. As the sizes of the cation and the anion are comparable, the attractive forces become stronger and the lattice energy is higher. When one of the ions is larger and the other much smaller, the forces become weaker and the compound will have lower lattice energy.

The enthalpy of solution (ΔH_{soln}) is the overall energy change when a solid ionic substance is dissolved. A more negative or less positive ΔH_{soln} generally favours higher solubility.

The solubility of Group 2 hydroxides increases down the group (e.g., $\text{Mg}(\text{OH})_2$ is sparingly soluble, $\text{Ba}(\text{OH})_2$ is quite soluble). Going down Group 2, both ΔH_{hyd} (for M^{2+}) and $\Delta H_{\text{lattice}}$ decrease. However, the decrease in lattice enthalpy is more significant than the decrease in hydration enthalpy. With smaller Group 2 metal ions, the lattice energy of hydroxides is higher and vice versa.

The solubility of Group 2 sulphates, (MSO_4) in water decreases down the group (e.g., MgSO_4 is soluble and BaSO_4 is insoluble).

	Solubility of hydroxides	Solubility of sulphates
Mg	less soluble	more soluble
Ca		
Sr		
Ba	more soluble	less soluble

Figure 17.4 Trends in solubility in group 2 hydroxides and sulphates



The sulphate ion (SO_4^{2-}) is relatively larger. While going down Group 2, both ΔH_{hyd} (for M^{2+}) and $\Delta H_{\text{lattice}}$ decrease. But, for a large anion like sulphate, the decrease in hydration enthalpy is more significant than the decrease in lattice enthalpy

Table 17.4 Solubility of Group 2 hydroxides and sulphates

Group 2 Hydroxides	Solubility at 298K (mol/100 g of water)	Group 2 Sulphates	Solubility at 298K (mol/100 g of water)
$\text{Mg}(\text{OH})_2$	2×10^{-5}	MgSO_4	1.83×10^{-1}
$\text{Ca}(\text{OH})_2$	1.5×10^{-3}	CaSO_4	4.66×10^{-3}
$\text{Sr}(\text{OH})_2$	3.4×10^{-3}	SrSO_4	7.11×10^{-5}
$\text{Ba}(\text{OH})_2$	1.5×10^{-2}	BaSO_4	9.43×10^{-7}

17.6 COMPLEX ION FORMATION

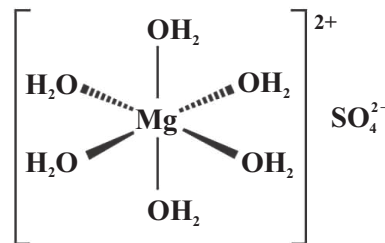
A complex ion is an ion in which a central metal is bonded to a number of surrounding electron donating species.

The central metal ion acts as a Lewis acid (electron pair acceptor), while the molecules or ions with lone pairs of electrons, e.g., H_2O , NH_3 , Cl^- , OH^- act as Lewis bases. The number of coordinate bonds formed between the central metal ion and the electron donors is called coordination number. Common coordination numbers are 2, 4, and 6.

While complex ion formation is more typical for transition metals (due to their available d-orbitals for bonding), Group 2 elements can also form complex ions, especially those at the top of the group. Their tendency to form complexes is far less pronounced than that of transition metals, but it's still significant in certain contexts.

The ability of a Group 2 metal ion to form a complex ion depends on its size and charge. Smaller ions have a higher charge density (high charge to size ratio), which makes them better at attracting electron-donating species. All Group 2 ions have a +2 charge, which provides an electrostatic attraction for electron pair donors.

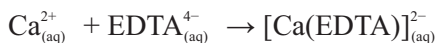
When Group 2 salts dissolve in water, the metal ions become hydrated. These are essentially complex ions where water molecules act as electron pair donors. For example, beryllium, being the smallest Group 2 ion, has a high charge density. It strongly attracts water molecules and forms a hydrated ion with a coordination number of 4 ($[\text{Be}(\text{H}_2\text{O})_4]^{2+}$). Magnesium ions are larger and usually form hexahydrate complexes, with a coordination number of 6 ($[\text{Mg}(\text{H}_2\text{O})_6]^{2+}$).



Larger ions like Ca^{2+} , Sr^{2+} , and Ba^{2+} also form hydrated ions, mostly with a coordination number of 6, though the strength of the interaction decreases down the group.

Group 2 ions, especially the smaller ones, can form stable complexes with the donors having more than one donatable electron pairs. These species can form more than one coordinate bonds to the same metal ion, creating a ring-like structure.

Calcium ion forms a complex ring structure with a six electron pair donor, EDTA (ethylenediaminetetraacetic acid).



This complex formation is used in water softening where EDTA removes Ca^{2+} and Mg^{2+} ions from hard water. EDTA can be used to remove toxic metal ions (including sometimes Ca^{2+} if levels are too high) from the body.



Ca-EDTA complex is used in medicines to remove metal ions from the body



Quick Check 17.3



- Why does MgSO_4 dissolve easily as compared to BaSO_4 ?
- How does lattice energy affect the solubility of Group 2 sulphates?
- Which hydroxide is more soluble: $\text{Ca}(\text{OH})_2$ or $\text{Sr}(\text{OH})_2$? Give reason.

17.7 EXTRACTION AND PURIFICATION OF GROUP 2 ELEMENTS AND THEIR COMPOUNDS

17.7.1 Magnesium Production from Seawater (Dow Process)

This is perhaps the most famous and industrially significant process. The "Dow Process" (or variations of it) is a multi-step chemical and electrochemical process used to extract magnesium metal from the vast reserves of magnesium ions (Mg^{2+}) present in seawater.

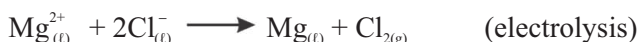
Seawater is treated with calcium hydroxide ($\text{Ca}(\text{OH})_2$), derived from limestone or oyster shells), which precipitates magnesium as insoluble magnesium hydroxide ($\text{Mg}(\text{OH})_2$).



Magnesium hydroxide is filtered and then reacted with hydrochloric acid (HCl) to form magnesium chloride (MgCl_2).



The magnesium chloride solution is then concentrated and dried. The molten MgCl_2 is subjected to electrolysis in large electrolytic cells. This is the final step that produces pure magnesium metal at the cathode and chlorine gas at the anode.



This process is famous for its ingenuity in extracting a valuable metal from an abundant, low-concentration source (sea water) on a massive industrial scale. It has revolutionized the magnesium production.

17.7.2 Production of Quicklime (CaO) from Limestone (CaCO₃)

This is one of the oldest and most fundamental industrial processes involving a Group 2 compound, calcium carbonate (limestone). Quicklime, or calcium oxide, is a vital chemical used in construction (cement, mortar), agriculture (soil treatment), metallurgy, and various chemical industries. Limestone is a naturally abundant sedimentary rock composed primarily of calcium carbonate. The production of quicklime involves heating limestone in a high-temperature furnace (a "lime kiln") to very high temperatures (typically 900-1000°C) in a process called calcination or thermal decomposition as shown in **Figure 17.5**.



In modern lime kilns, the ingredients are heated by circulating hot gases at the reaction temperature. The reaction is reversible in the closed container but is made to occur faster by removing CO₂ continuously.

This removal shifts the equilibrium to the right, resulting in a faster production of a large amount of the product.

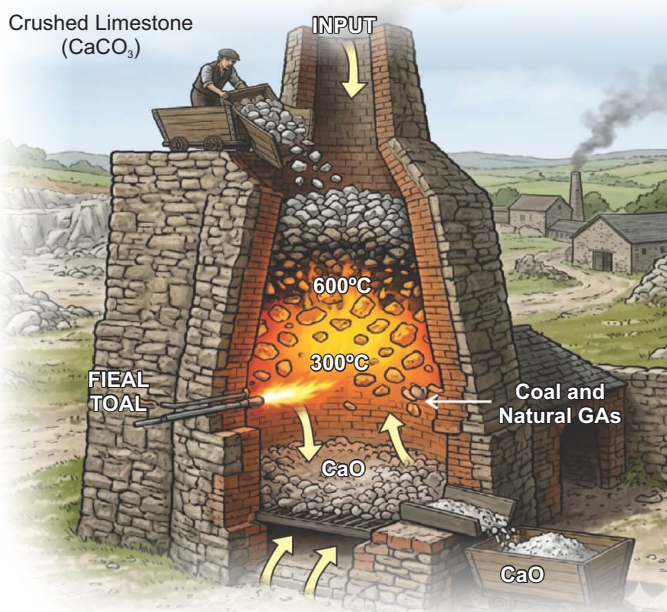


Figure 17.5 The reaction of CaCO₃ is used to produce lime (CaO), which has many applications

17.8 USES OF GROUP 2 COMPOUNDS

Group 2 compounds have diverse uses in industries, everyday life, medicine, and agriculture, largely due to their basic nature and varying solubility.

17.8.1 Role of Group 2 Compounds in Industry and Everyday Life

i. Construction

Calcium carbonate (CaCO₃) is found as limestone, marble, and chalk. This is widely used as a building material, in cement, concrete, and as a filler in paper and plastics. Calcium oxide (CaO, quicklime) and calcium hydroxide (Ca(OH)₂, slaked lime) is used in making cement, mortar, and plaster. Quicklime is also used in the steel production to remove impurities. Calcium sulphate (CaSO₄·2H₂O, gypsum) is used to make plasterboard (drywall) and plaster of Paris (CaSO₄·½H₂O).



ii. Environment

Calcium oxide (CaO) and calcium carbonate (CaCO_3) are used in "flue gas desulphurization" (wet scrubbing) to remove acidic sulphur dioxide (SO_2) from power plant emission and preventing acid rain. Magnesium oxide (MgO) is used as a refractory material (lining furnaces) due to its high melting point.



Did You Know?

Magnesium (metal) is used in lightweight alloys (e.g., aerospace, automotive), fireworks, and flares due to its bright burning. Strontium compounds are used to produce red colour in fireworks and flares. Beryllium is used in alloys to increase strength (e.g., in springs, aerospace components) and in X-ray tubes as it is transparent to X-rays.

17.8.2 Medicine

Magnesium hydroxide ($\text{Mg}(\text{OH})_2$, "Milk of Magnesia") is used to neutralize excess stomach acid and as a mild laxative. Its low solubility makes it safe to use. Calcium carbonate (CaCO_3) is also used in indigestion tablets as an antacid. Calcium compounds (calcium carbonate, calcium citrate, etc.) are essential for strong bones and teeth and are widely used as dietary calcium supplements to prevent osteoporosis. Magnesium compounds (magnesium sulphate, magnesium citrate, etc.) are important for muscle and nerve function and used to treat magnesium deficiencies.

Epsom salts ($\text{MgSO}_4 \cdot 7\text{H}_2\text{O}$) are used as a laxative and in baths. Barium sulphate (BaSO_4) is used in "barium meals" for X-ray imaging of the digestive system. It is opaque to X-rays and is safe because it's highly insoluble and passes through the body without being absorbed.



17.8.3 Agriculture

Calcium carbonate (CaCO_3) and calcium hydroxide ($\text{Ca}(\text{OH})_2$) are added to acidic soils to increase pH (neutralize acidity), making the soil more suitable for crop growth. Calcium and magnesium are essential plant nutrients. Calcium is crucial for cell wall development, while magnesium is a central atom in chlorophyll, which is vital for photosynthesis. Compounds like calcium nitrate or magnesium sulphate (Epsom salts) can be used as fertilizers.



Quick Check 17.4



- Write the balanced equation for the electrolysis step in the Dow Process.
- Write the balanced equation for producing quicklime (CaO) from limestone.
- State one agricultural use of CaCO_3 and the chemical principle involved.



- X) Why does Be^{2+} form complexes more easily than Ba^{2+} ?
- a) Larger size
b) Lower charge density
c) Higher charge density
d) More d-orbitals

Q2. SHORT ANSWER QUESTIONS

- a) Exactly 0.1 moles of calcium hydroxide and barium hydroxide are added to separate beakers containing 100 cm^3 of water and stirred to form saturated solutions. Explain which solution has the higher pH value.
- b) The size of dichromate ion is larger than the sulphate ion. Following the pattern for the solubilities of Group 2 sulphates, predict which of calcium dichromate and strontium dichromate is more soluble in water?
- c) Write balanced equations for the reaction of Ba with cold water.
- d) Why does Be metal form a protective layer on reacting with air while other members do not do so? Explain in terms of the strength of bonding between Be^{2+} and oxide ion.
- e) Predict the products of the thermal decomposition of barium nitrate. Write the chemical equation.
- f) Why does solubility of Group 2 hydroxides increase in terms of the relative changes in ΔH_{hyd} and $\Delta H_{\text{lattice}}$?
- g) In Dow Process, write the balanced equation for the precipitation of magnesium ions from seawater.
- h) State one medical use of BaSO_4 and $\text{Mg}(\text{OH})_2$ each.

Q3. CONSTRUCTED RESPONSE QUESTIONS

- a) Why the melting point and density of beryllium are higher than other Group 2 elements?
- b) Why are Group 1 metals more reactive than Group 2 metals in the same period?
- c) Explain why calcium hydroxide is used in agriculture.

DESCRIPTIVE QUESTIONS

- Q4. Describe the reactivity of Group 2 elements with water and dilute hydrochloric acid. Provide relevant chemical equations and differences in their reactivity.
- Q5. Explain the thermal decomposition of carbonates and nitrates of Group 2 elements. Give reason and relative order of the ease of thermal stability.
- Q6. Explain the solubility of sulphates and hydroxides of Group 2 elements, and discuss the trend in their solubility down the group with appropriate examples.
- Q7. Explain the process of extraction of Mg through Dow's method.



18

TRANSITION METALS

Student Learning Outcomes

[C-12- B-16 to C-12-B-46]

- ⊙ Define a transition element as a d-block element which forms one or more stable ions with incomplete d orbitals.
- ⊙ Identify the general physical and chemical properties of the first row of transition elements, titanium to copper.
- ⊙ Identify the properties of transition elements (Some examples include:
 - a) they have variable oxidation states
 - b) they behave as catalysts
 - c) they form complex ions
 - d) they form coloured compounds
- ⊙ Explain why transition elements have variable oxidation states in terms of the similarity in energy of the 3d and the 4s subshells.
- ⊙ Explain why transition elements form complex ions in terms of vacant d orbitals that are energetically accessible.
- ⊙ Explain why transition elements behave as catalysts in terms of having more than one stable oxidation state, and vacant d orbitals that are energetically accessible and can form dative bonds with ligands.
- ⊙ Define the term complex as a molecule or ion formed by a central metal atom/ion surrounded by one or more ligands.
- ⊙ Define the term ligand as a species that contains a lone pair of electrons that forms a dative covalent bond to a central metal atom/ion.
- ⊙ State what is meant by coordination number.
- ⊙ Use the term monodentate ligand including as examples H_2O , NH_3 , Cl^- and CN^- .
- ⊙ Use the term bidentate ligand including as examples 1,2 diaminoethane, $\text{H}_2\text{NCH}_2\text{CH}_2\text{NH}_2$ and the ethanedioate ion, $\text{C}_2\text{O}_4^{2-}$; polydentate ligand including as an example EDTA.
- ⊙ Describe the geometry (shape and bond angles) of transition element complexes which are linear, square planar, tetrahedral or octahedral.
- ⊙ Predict the formula and charge of a complex ion, given the metal ion, its charge or oxidation state, the ligand and its coordination number or geometry.
- ⊙ Use the terms degenerate and non-degenerate d orbitals.
- ⊙ Describe the splitting of degenerate d orbitals into two non-degenerate sets of d orbitals of higher energy, and use of ΔE in:
 - a) Octahedral complexes, two higher E and three lower E d orbitals
 - b) Tetrahedral complexes, three higher E and two lower E d orbitals
- ⊙ Explain why transition elements form coloured compounds in terms of the frequency of light absorbed as an electron is promoted between two non-degenerate orbitals.
- ⊙ Describe, in qualitative terms, the effects of different ligands on ΔE , frequency of light absorbed, and hence the complementary colour that is observed.



- ⊙ Sketch the shape of a $3d_{xy}$ orbital and $3d_z$ orbital.
- ⊙ Explain the reactions of transition elements with ligands to form complexes, including the complexes of copper(II) and cobalt(II) ions with water and ammonia molecules and hydroxide and chloride ions.
- ⊙ Explain qualitatively that ligand exchange can occur, including the complexes of copper(II) ions and cobalt(II) ions with water and ammonia molecules and hydroxide and chloride ions.
- ⊙ Use the complexes of copper(II) ions and cobalt(II) ions with water and ammonia molecules and hydroxide, chloride ions as examples of ligand exchange affecting the colour observed.
- ⊙ Define the stability constant, K_{stab} , of a complex as the equilibrium constant for the formation of the complex ion in a solvent (from its constituent ions or molecules).
- ⊙ Write an expression for a K_{stab} of a complex [H_2O] should not be included).
- ⊙ Use K_{stab} expressions to perform calculations.
- ⊙ Explain ligand exchanges in terms of K_{stab} values and understand that a large K_{stab} is due to the formation of a stable complex ion."
- ⊙ Describe the types of stereoisomerism shown by complexes, including those associated with bidentate ligands.
- ⊙ Geometrical (cis-trans) isomerism, e.g. square planar such as $[Pt(NH_3)_2Cl_2]$ and octahedral such as $[Co(NH_3)_4(H_2O)_2]^{3+}$ and $[Ni(H_2NCH_2CH_2NH_2)_2(H_2O)_2]^{2+}$
- ⊙ Deduce the overall polarity of complexes.
- ⊙ Optical isomerism, e.g. $[Ni(H_2NCH_2CH_2NH_2)_3]^{2+}$ and $[Ni(H_2NCH_2CH_2NH_2)(H_2O)_2]^{2+}$.
- ⊙ Predict, using E^0 values, the feasibility of redox reactions involving transition elements and their ions
- ⊙ Analyse reactions involving $MnO_4^- / C_2O_4^{2-}$ in acid solution given suitable data (including describing the reaction and doing calculations).
- ⊙ Analyse reactions involving MnO_4^- / Fe^{2+} in acid solution given suitable data (including describing the reaction and doing calculations).
- ⊙ Analyse reactions involving Cu^{2+} / I^- given suitable data (including describing the reaction and doing calculations).
- ⊙ Perform calculations involving other redox systems given suitable data.

Transition metals, found in d and f blocks of the modern periodic table, are characterized by their high density, conductivity, and ability to form colourful compounds. Iron stands as the backbone of human civilization; it has played a key role in the industrial revolution for the creation of durable tools and modern steel infrastructure. Copper, silver and gold are well known since ancient ages as symbols of wealth and prestige. They have been historically used for coinage and jewellery; they remain essential today in high-end electronics and dentistry due to their exceptional corrosion resistance and conductivity. From the steel in our cars to the gold in our smartphones, transition metals are highly valuable for our modern life. The transition metals can be classified on the basis of their electronic configuration into d-block (if their outermost electrons are being filled in d-orbitals) and f-block (if their outermost electrons are being filled in f-orbitals). However, as the d-block transition elements are more common in our daily life usage, and among them first row transition elements i.e., 3d-series, have a key role in human civilization and development, therefore, we shall focus on these 3d transition elements onwards in this chapter.



18.1 FIRST ROW TRANSITION ELEMENTS (3d)

First row transition elements are the elements found in the d block of the Periodic Table, having partially filled d-orbitals in any of their stable oxidation state. They are called transition elements because they show transitions between variable oxidation states. Although d-block elements are composed of groups 3 to 12, however, zinc and scandium cannot be classified as transition elements. Zn forms only one ion (Zn^{2+}), which has a complete 3d subshell, the electronic configuration of Zn^{2+} is $[Ar] 3d^{10} 4s^0$.

18.1.1 Electronic Configuration of Transition Metals and their Ions

Electronic configuration of the transition elements usually follows Aufbau principle, except in chromium and copper. These two elements show anomaly due to acquiring stability of half-filled (chromium; $3d^5$) and completely filled (copper; $3d^{10}$) d-subshell. This stabilizing factor makes the electron cloud of these two elements more symmetrical and provides a better shielding effect to nucleus. The electronic configuration of first row of transition elements in their neutral (M^0), dipositive (M^{2+}) and tripositive (M^{3+}) oxidation states are given in the following **Table 18.1**.

Table 18.1 Electronic configurations of first row transition elements

Element	Symbol	Atomic Number	Electronic Configuration		
			(M^0)	(M^{2+})	(M^{3+})
Titanium	Ti	22	$[Ar] 3d^2 4s^2$	$[Ar] 3d^2 4s^0$	$[Ar] 3d^1 4s^0$
Vanadium	V	23	$[Ar] 3d^3 4s^2$	$[Ar] 3d^3 4s^0$	$[Ar] 3d^2 4s^0$
Chromium	Cr	24	$[Ar] 3d^5 4s^1$	$[Ar] 3d^4 4s^0$	$[Ar] 3d^3 4s^0$
Manganese	Mn	25	$[Ar] 3d^5 4s^2$	$[Ar] 3d^5 4s^0$	$[Ar] 3d^4 4s^0$
Iron	Fe	26	$[Ar] 3d^6 4s^2$	$[Ar] 3d^6 4s^0$	$[Ar] 3d^5 4s^0$
Cobalt	Co	27	$[Ar] 3d^7 4s^2$	$[Ar] 3d^7 4s^0$	$[Ar] 3d^6 4s^0$
Nickel	Ni	28	$[Ar] 3d^8 4s^2$	$[Ar] 3d^8 4s^0$	$[Ar] 3d^7 4s^0$
Copper	Cu	29	$[Ar] 3d^{10} 4s^1$	$[Ar] 3d^9 4s^0$	$[Ar] 3d^8 4s^0$

18.2 PROPERTIES OF TRANSITION ELEMENTS

The first row of transition elements includes the metals from titanium to copper. The common physical and chemical properties arising due to their partially filled 3d orbitals are given as under.



18.2.1 Physical Properties

- The transition metals exist as hard and rigid solids.
- Except copper, which is reddish brown, others occur as silvery or grey lustrous metals.
- Their atomic radius usually decreases from left to right, however, at the end it increases a little. This increase may be associated to the stability acquired by copper due to its completely filled d-subshell.
- They have high melting and boiling points. The melting and boiling points of these elements show a variable trend from left to right as shown in **Figure 18.1**.
- They are good conductors of electricity and heat.
- They have high densities that generally increase across the row from titanium to copper. This is due to a regular build-up of nuclear charge and atomic size shrinkage.
- They possess a shiny surface, and are malleable (can be hammered into thin sheets), and ductile (can be drawn into wires).
- Most of them and their compounds are paramagnetic due to the presence of unpaired d electrons.

18.2.2 Chemical Properties

- Transition metals have variable oxidation states as they can lose varying number of electrons to form stable ions (e.g., Fe^{2+} and Fe^{3+}).
- They have a high tendency to form coordination compounds (complexes) by accepting lone pairs of electrons from ligands into vacant d-orbitals.
- They form coloured ions and complexes due to the transition of electrons from lower energy to higher energy level as a result of absorption of light.
- These metals and their compounds behave as catalysts because they can easily change oxidation states.

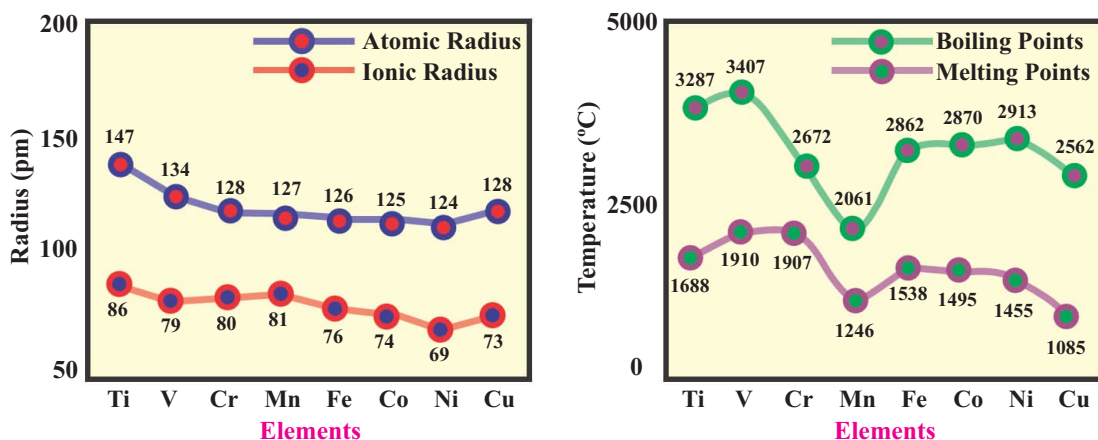



Figure 18.1 Atomic radii, ionic radii, melting points and boiling points of 3d transition elements



18.2.3 Variable Oxidation States

First row transition elements show variable oxidation states because the 3d and 4s subshells have comparable (very similar) energy. The energy difference between the inner 3d subshell and the outermost 4s subshell is very small. So, like 4s electrons, the 3d electrons can also easily be lost. This means that not only the electrons in the outermost 4s subshell but also the electrons in the partially filled 3d subshell are involved in chemical bonding.

A 3d metal atom can lose:

-  Only the 4s electrons, usually giving the common +2 oxidation state.
-  The 4s electrons plus a variable number of 3d electrons, giving the higher oxidation states.

Among these metals, Mn has the maximum oxidation state of +7. The oxidation state of transition elements varies in parabolic trend from left to right within d-block. The various oxidation states of 3d elements are provided in **Table 18.2**.

Table 18.2 Common oxidation states of 3d elements

Ti	V	Cr	Mn	Fe	Co	Ni	Cu
			+7				
		+6	+6	+6			
	+5	+5	+5	+5	+5		
+4	+4	+4	+4	+4	+4	+4	
+3	+3	+3	+3	+3	+3	+3	+3
+2	+2	+2	+2	+2	+2	+2	+2
			+1	+1			+1



Quick Check 18.1



- a) Write down electronic configuration of Co^{2+} and Co^{3+} , and find the number of unpaired electrons in d-orbitals.
- b) Why are the density and melting points of transition metals much higher than Group 1 metals?
- c) The Sc^{3+} ion is $[\text{Ar}] 3d^0 4s^0$. Why is scandium not classified as a transition element?

18.2.4 Transition Metals as Catalysts

Transition elements act as effective catalysts to carry out various chemical reactions. They can easily switch between their different stable oxidation states (e.g., $\text{Fe}^{2+} \rightleftharpoons \text{Fe}^{3+}$). This allows the metal ion to form an unstable intermediate compound with a reactant molecule. The intermediate then quickly reacts to form the final product and regenerates the catalyst back to its original oxidation state, providing a reaction pathway with lower activation energy. This process usually occurs in homogenous catalysis. For example, nickel salts are used in the preparation of acrylic acid from acetylene, involve the oxidation states of Ni(0) and Ni(II).



Another characteristic of transition metals is their vacant d-orbitals that are energetically accessible. Reactant molecules attach with the catalyst surface and form a temporary activated complex on the surface, which holds the reactants in the correct orientation, lowering the activation energy required for the reaction to occur. After the reaction, the products desorb, and the catalyst is ready for the next cycle. This process is generally observed in heterogeneous catalysis. A classic example of heterogeneous catalysis is the use of solid iron to accelerate the reaction between nitrogen and hydrogen gases to form ammonia in the Haber Process.



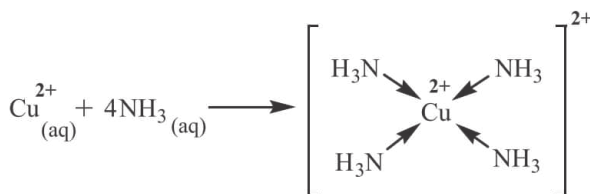
Quick Check 18.2



- How Vanadium can show the range of oxidation states from +2 to +5?
- What is the role of a ligand in forming a complex ion, and what type of bond is formed?
- Why transition metals use both 4s and 3d electrons in bonding, unlike s-block elements.
- Write the electronic configuration for Fe^{3+} . Why is the $\text{Fe}^{2+}/\text{Fe}^{3+}$ change useful in catalysis?
- Which properties of transition metals enable them to be used as heterogeneous catalysts and homogeneous catalysts.

18.3 TRANSITION METAL COMPLEXES

Transition elements form complex ions because they have vacant (empty) d orbitals that are energetically accessible to accept electron pairs. The central transition metal ion (e.g., Fe^{3+} or Cu^{2+} has partially filled or empty (n-1)d orbitals.



The energy of these empty d-orbitals is low enough (accessible) to participate in bond formation. The vacant d-orbitals on the metal ion accept the lone pairs of electrons donated by the ligands, forming coordinate covalent bonds (or dative bonds). The electron pair donor species (molecules or ions, like H_2O , NH_3 or Cl^-) are called ligands. This donation and acceptance of electron pairs create a stable complex ion (or coordination compound).

A metal complex (or coordination compound) is a molecule or ion that forms when a central metal atom or ion is surrounded by a number of electron donor species (molecules or ions). A transition element acts as a Lewis acid (electron pair acceptor) in complex formation.

A ligand is a molecule or ion (for example, H_2O , NH_3 or Cl^-) that possesses at least one lone pair of electrons and forms a coordinate covalent bond (dative bond) to the central metal atom or ion in a complex. The word "ligand" originates from the Latin "*ligare*", meaning "to bind". It acts as a Lewis base because it donates an electron pair.

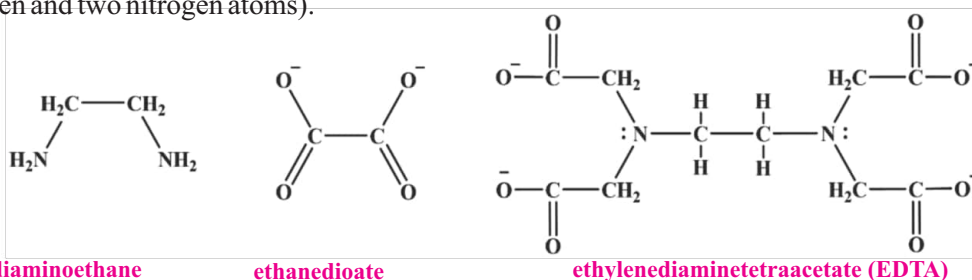
Ligands can be classified into different categories. The negatively charged electron pair donor species are called anionic ligands. These are the most abundant type of ligands. The most common examples are Cl^- , CN^- , OH^- , $\text{C}_2\text{O}_4^{2-}$ etc. Their names usually end at "-o", e.g., chloride becomes "chloro" and cyanide becomes "cyano" etc.



The neutral molecular species which are able to donate pair of electrons to form the transition metal complexes are called neutral ligands. For example, H_2O , NH_3 , CO , etc. Their names usually remain the same, though some have special names like H_2O (aqua), NH_3 (ammine) and CO (carbonyl). The positively charged electron pair donating species are called cationic ligands. They are rare and their names often ends at “-ium”. For example, NO^+ (nitrosonium), $\text{NH}_2\text{-NH}_3^+$ (hydrazinium) etc.

A monodentate ligand is a species that can donate only one pair of electrons to the central metal atom or ion. Some examples are H_2O , NH_3 , CO , Cl^- , OH^- and CN^- etc. In each case, only a single atom on the ligand forms the dative covalent bond to the metal. Bidentate ligands can donate two electron pairs to the central metal atom/ion. Typical examples are 1,2-diaminoethane (also known as ethylenediamine) and ethanedioate (or oxalate) ion. In 1,2-diaminoethane ($\text{H}_2\text{NCH}_2\text{CH}_2\text{NH}_2$, abbreviated as *en*), each of the two nitrogen (N) atoms donate a lone pair to the metal. In the ethanedioate ion ($\text{C}_2\text{O}_4^{2-}$), two oxygen (O) atoms, one from each carboxyl group, donate electron pairs.

A polydentate ligand is a general term used for any ligand that forms more than two dative bonds to a single central metal atom/ion. Ethylenediaminetetraacetate ion (EDTA) is a common example. It is a hexadentate ligand because it can attach to a metal ion using six donor atoms (four oxygen and two nitrogen atoms).



The coordination number is the total number of dative bonds formed between ligands and the central metal atom or ion in a complex. For example, in the complex ion $[\text{Fe}(\text{CN})_6]^{4-}$, the central metal ion Fe^{2+} is bonded to six CN^- ligands, so the coordination number of the metal ion is 6 as shown in **Figure 18.2**. The coordination number determines the overall structure of the complexes.

A coordination sphere is the central metal atom or ion and the directly bonded ligands (molecules or ions) surrounding it within a coordination compound. It defines the immediate chemical environment, is usually written inside square brackets [Complex].

The charge on coordination sphere is the arithmetic sum of the charges of central metal atom or ion and ligands. Whereas, the charge on the metal atom or ion will be the difference of the charge on sphere and total charge of ligands.

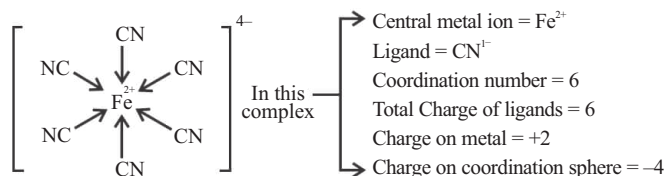


Figure 18.2 Hexacyanoferrate (II) complex and its components



18.4 PREDICTING FORMULA AND CHARGE OF A COMPLEX ION

The formula and charge of a complex ion are determined by combining the central metal ion, its oxidation state, and the ligands along with their charges. The general structure of a complex ion is $[M(L)_x]^{\pm y}$. Where, M is the central metal ion, L is the ligand, x is the number of ligand (determined by the coordination number) and $\pm y$ is the overall charge of the complex ion.

Table 18.3. Predicting formula and charge of a complex ion

Complex type	Cationic Complex	Anionic Complex	Neutral Complex
Metal Ion	Co	Fe	Ni
Oxidation state of metal	+3	+2	0
Ligand	NH ₃ (Ammine)	CN ⁻ (Cyano)	CO (Carbonyl)
Ligand type and charge	Neutral, 0	Anionic, -1	Neutral, 0
Coordination number	6	6	4
Determination of formula	Place Metal (Co) first, then Ligand (NH ₃) with its number as a subscript (6), all inside square brackets [].	Place Metal (Fe) first, then Ligand (CN) with its number as a subscript (6), inside brackets [].	Place Metal (Ni) first, then Ligand (CO) with its number as a subscript (4), inside brackets [].
Calculate the charge	$(+3) + [6 \times (0)] = +3$	$(+2) + [6 \times (-1)] = -4$	$(0) + [4 \times (0)] = 0$
Explanation of charge calculation of complex	Metal charge (+3) + (Number of ligands \times Ligand charge). A positive sum.	Metal charge (+2) + (Number of ligands \times Ligand charge). A negative sum.	Metal charge (0) + (Number of ligands \times Ligand charge). A zero sum.
Final form and charge	$[Co(NH_3)_6]^{3+}$	$[Fe(CN)_6]^{4-}$	$[Ni(CO)_4]$



18.5 GEOMETRY OF TRANSITION METAL COMPLEXES

Transition metal complexes exhibit specific geometries (shapes) depending upon the electronic configuration and coordination number (number of donor atoms attached) of the metal, and the nature of the ligands. The common geometries found in transition metal complexes are explained below:

- Linear:** In this geometry, the two ligands are attached on opposite sides of the central metal ion at an angle of 180° . Typical examples of linear complexes are $[\text{Ag}(\text{NH}_3)_2]\text{Cl}$ and $\text{K}[\text{Ag}(\text{CN})_2]$.
- Square planar:** In square planar shape, the central metal ion and the four ligands lie in the same plane, at the corners of a square with bond angle 90° . This geometry is characteristic of d^8 metal ions (e.g., Ni^{2+} and Pt^{2+}) with ligands like, NH_3 and CN^- . Examples are: $[\text{Ni}(\text{CN})_4]^{2-}$ and $[\text{Pt}(\text{NH}_3)_4]^{2+}$.
- Tetrahedral:** In tetrahedral complexes, four ligands are directed at the corners of a tetrahedron with bond angle of 109.5° . Such shapes are common when the metal ion has a d^7 , d^8 and d^{10} electron configuration for example, $[\text{CoCl}_4]^{2-}$ and $[\text{MnCl}_4]^{2-}$.

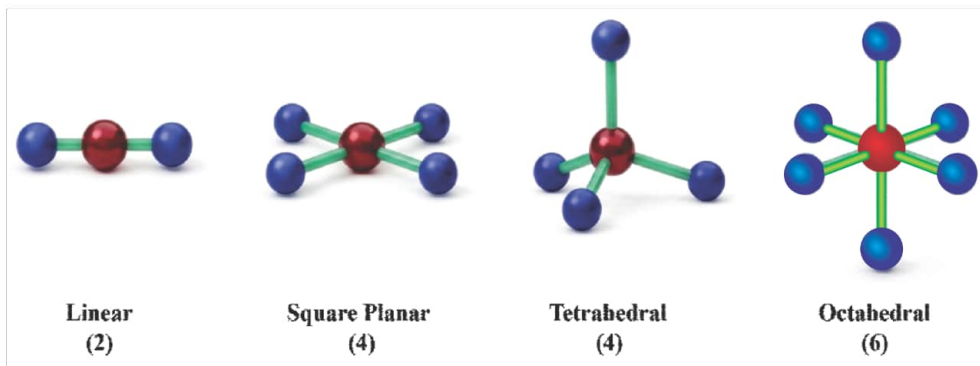


Figure 18.3 Shapes of Transition Metal complexes

- Octahedral:** In this geometry, the central metal ion is surrounded by six ligands, coming along the x, y and z axes. Four ligands form a square plane with an angle of 90° , and the other two are positioned above and below this plane at an angle of 180° . This is the most common geometry for transition metal complexes. The common examples are $[\text{Cr}(\text{NH}_3)_6]^{3+}$ and $[\text{Co}(\text{en})_3]^{3+}$.



Quick Check 18.3



- How Lewis acid base concept explains the transition metal complex formation?
- Determine the overall charge of a complex ion formed from a Cr^{3+} metal ion with six neutral H_2O ligands and a coordination number of 6. Show your calculation.
- Predict the likely geometry for the complex ion $[\text{MnCl}_4]^{2-}$, given that the central metal ion has a d^5 electron configuration and a coordination number of 4.
- EDTA is described as a hexadentate ligand. Explain what "hexadentate" means in terms of coordinate covalent bonds formed with a single metal ion.
- Identify the two essential features of a transition metal ion that enable it to form complex ions.



18.6 COLOUR OF COMPLEXES

The d-orbitals have a characteristic cloverleaf shape, generally resembling four lobes or two dumbbells in a plane, with five distinct orbitals d_{xy} , d_{xz} , d_{yz} , $d_{x^2-y^2}$, and d_{z^2} . In an isolated atom, all five d orbitals have the same energy (degenerate), but their different shapes lead to different energies in complex ions (non-degenerate). Their spatial (in space) arrangements and energy levels decide the bonding, colour, and magnetic properties of transition metals. When ligands approach the metal ion to form an octahedral or a tetrahedral complex, they create an electric field that causes the five d orbitals to split into two groups with different energies, making them non-degenerate. The energy difference is related to the extent of splitting between the two sets of orbitals and is represented by Δ .

Octahedral Complexes

In octahedral complexes (with six ligands), like $[\text{Ti}(\text{H}_2\text{O})_6]^{3+}$, the five d orbitals split into two sets; three lower-energy orbitals including, d_{xy} , d_{xz} , d_{yz} and two higher-energy orbitals; $d_{x^2-y^2}$, d_{z^2} (**Figure 18.4**).

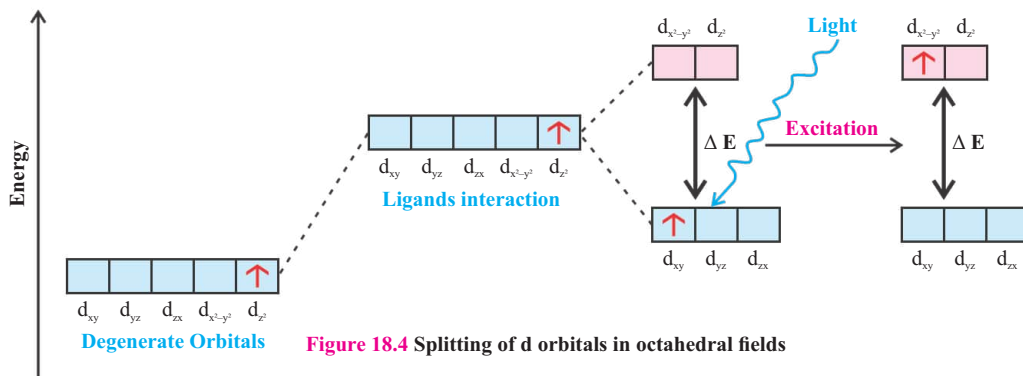


Figure 18.4 Splitting of d orbitals in octahedral fields

Tetrahedral Complexes

In tetrahedral complexes (with four ligands), like $[\text{CuCl}_4]^{2-}$, the splitting is inverted with three higher-energy orbitals d_{xy} , d_{xz} , d_{yz} and two lower-energy orbitals $d_{x^2-y^2}$, d_{z^2} . The magnitude of splitting in tetrahedral complexes is smaller than that in octahedral complexes (**Figure .18.5**).

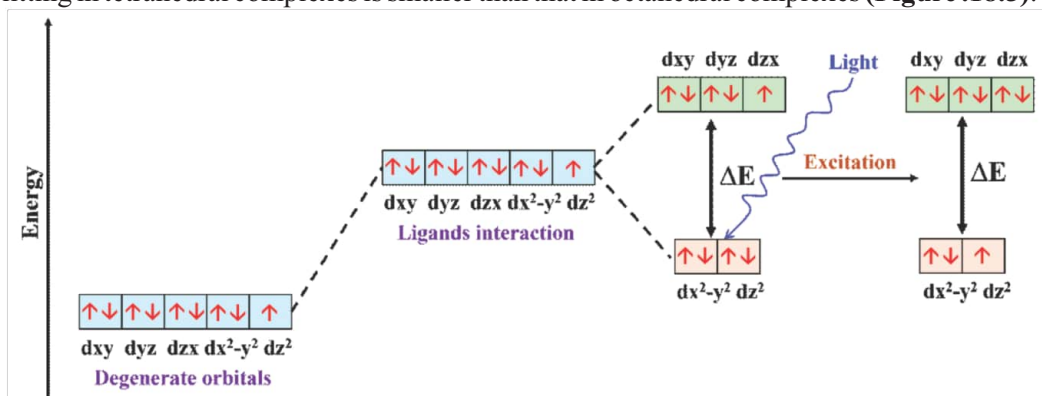


Figure 18.5 Splitting of d orbitals in tetrahedral fields



18.6.1 Colour Formation

When white light falls on the compound, it may get absorbed completely, and the complex appears black. The compound may reflect or transmit the whole light, and appears to be white. Another option is that the compound may absorb some of the light and reflect the remaining part, then complex shows different colours depending upon colour of the light reflected. The colour is produced in the substances due to absorption and emission of light in the visible region of the spectrum according to the following colour scheme (**Figure 18.6**).

The colour we see is the opposite (complementary colour) to the colour (frequency/wavelength) of light that is absorbed. For example, if a complex absorbs yellow light, it appears violet.

The electrons in a lower-energy d-orbital absorb light and are promoted (excited) to a higher-energy d-orbital. The light energy involved in the transition of electron is responsible for showing definite colour of the complex. The unabsorbed light is transmitted and it decides the nature of the colour. This process is called a d-d transition. The energy required for a d-d transition, corresponds to a specific frequency (ν) and wavelength (λ) of visible light according to the Planck's equation, $\Delta E = h\nu = hc/\lambda$ (h is Planck's constant and c is speed of light).

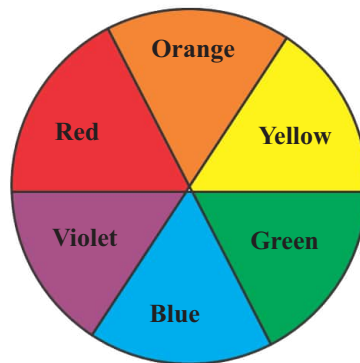
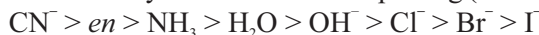


Figure 18.6 Colour wheel showing complementary colours

Effect of Different Ligands on ΔE and Colour

The nature of the ligand affects the magnitude of the splitting, ΔE . Some ligands like NH_3 , CN^- cause larger splitting, increasing the energy gap (ΔE). Whereas, for some other ligands like Cl^- , I^- , ΔE is smaller. A larger ΔE means a higher frequency, (shorter wavelength) of light must be absorbed that is in the region of violet or blue colour. Corresponding to that a yellow light is reflected giving the compound a yellow colour. Some complexes absorb low-energy light (red/orange) and appear blue or green according to the complementary colour scheme. Ligands can be arranged in order of their ability to cause d-orbital splitting (from high ΔE to low ΔE):



Quick Check 18.4



- How does the presence of ligands affect the degeneracy of d-orbitals in a complex ion?
- Describe the key difference in d-orbital splitting patterns between octahedral complexes and tetrahedral complexes.
- Explain the relationship between the absorbed light energy (ΔE) and the observed colour of a transition metal complex. Reference Planck's equation ($\Delta E = h\nu = hc/\lambda$).
- If a complex containing the ligand Cl^- absorbs light in the red/orange region of the spectrum, what general colour range would you expect the complex to appear?
- Explain the phenomenon (d-d transitions) responsible for the colour of transition metal compounds.

18.7 LIGAND EXCHANGE REACTIONS OF COMPLEXES

If new complex to be formed is more stable than substitution of ligands occurs and it will change the properties of the new complex, like colour, structure and reactivity. The complexes of copper(II) and cobalt(II) ions can be used to show ligand substitution reactions.



18.7.1 Ligand Exchange Reactions of Copper(II) Complexes

Whenever, we write $\text{Cu}_{(\text{aq})}^{2+}$, we actually refer to the complex ion $[\text{Cu}(\text{H}_2\text{O})_6]^{2+}$. This ion gives blue colour to the solution of a copper(II) salt, for example, copper sulphate. On adding sodium hydroxide to a copper(II) solution, a light blue precipitate is formed. Two water ligands are replaced by two hydroxide ions in this reaction.



If concentrated ammonia solution is added, the light blue precipitate dissolves resulting in a dark blue solution.

The structure of $[\text{Cu}(\text{NH}_3)_4(\text{H}_2\text{O})_2]^{2+}$ is shown in **Figure 18.7**. Water ligands in $[\text{Cu}(\text{H}_2\text{O})_6]^{2+}$ can also be exchanged directly with ammonia by replacing four water molecules.

For simplicity, $[\text{Cu}(\text{NH}_3)_4(\text{H}_2\text{O})_2]^{2+}$ is usually written as $[\text{Cu}(\text{NH}_3)_4]^{2+}$.

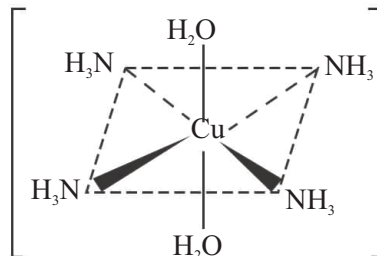
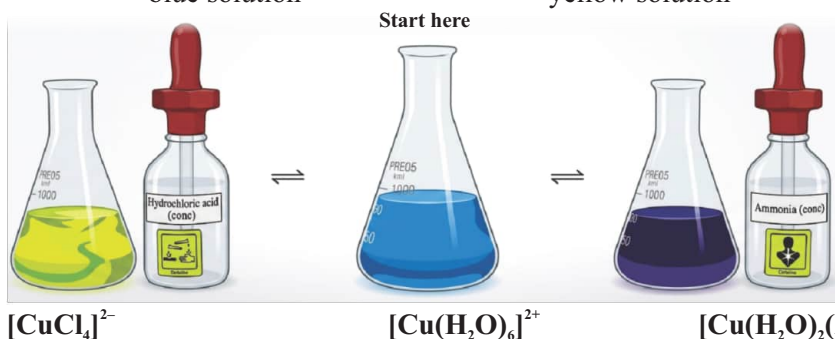
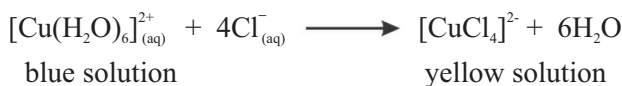


Figure 18.7 Structure of $[\text{Cu}(\text{NH}_3)_4(\text{H}_2\text{O})_2]_{(\text{aq})}^{2+}$ ion



The chloride ions can also replace water ligands in $[\text{Cu}(\text{H}_2\text{O})_6]^{2+}$ on addition of concentrated hydrochloric acid drop by drop. A yellow solution is obtained that contains the complex ion $[\text{CuCl}_4]^{2-}$ (**Figure 18.8**).



This is yellow-green complex forms on adding conc. HCl.

The well-known blue Cu^{2+} complex with water.

This dark blue complex forms on adding conc. NH_3 .

Figure 18.8 Colour changes as a result ligand exchange reaction

18.7.2 Ligand Exchange Reactions of Cobalt(II) Complexes

Cobalt(II) salts also form complex ions in aqueous solution. As mentioned in the case of copper(II), a $\text{Co}_{(\text{aq})}^{2+}$ ion refers to the complex ion $[\text{Co}(\text{H}_2\text{O})_6]^{2+}$. This ion gives a pink colour to the aqueous solution of cobalt(II) sulphate. On adding sodium hydroxide solution, we see a blue



precipitate of cobalt(II) hydroxide, which may turn pink on standing.



When excess ammonia solution is added to the cobalt(II) hydroxide precipitate, a ligand exchange reaction takes place. The ammonia ligands replace the water and hydroxide ligands, forming a soluble ammine complex, hexaamminecobalt(II) ions. The colour of the solution turns yellow (**Figure 18.9**).

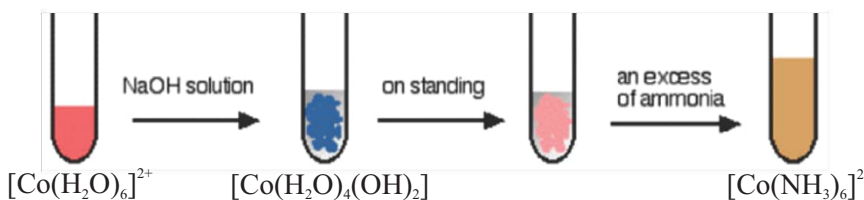
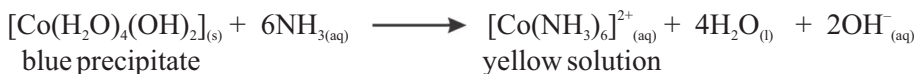


Figure 18.9 Colour changes in $[\text{Co}(\text{H}_2\text{O})_6]^{2+}$ on addition of hydroxide and NH_3

Water ligands in $[\text{Co}(\text{H}_2\text{O})_6]^{2+}$ can also be exchanged directly with ammonia ligands by adding concentrated ammonia solution.



The addition of concentrated hydrochloric acid drop by drop to an aqueous solution of cobalt(II) ions results in the formation of a blue solution containing the tetrahedral complex $[\text{CoCl}_4]^{2-}_{(\text{aq})}$ (**Figure 18.10**).

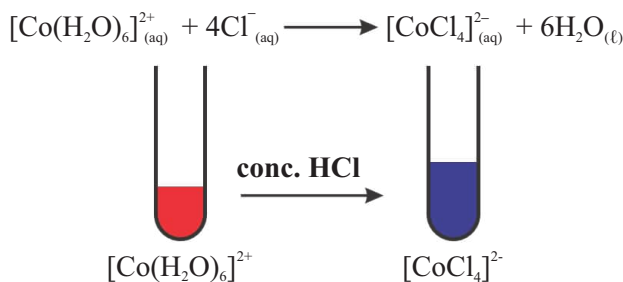


Figure 18.10 Exchange of water molecules by chloride ions in a Co(II) complex

Aqueous cobalt(II) ions usually form tetrahedral complexes with monodentate anionic ligands such as Cl^- , OH^- and SCN^- .

18.7.3 Effect of Ligand Exchange on the Colour of Complexes

The exchange of ligands in a complex changes the magnitude of splitting for the metal ion. As a result, the frequency of absorbed light also changes, leading to a change in the observed colour. In each case, the new complex has a different ΔE because the new ligands (NH_3 or Cl^-) makes more stable complex than the original H_2O ligands, leading to a different absorbed frequency and a different observed colour.



Table 18.4 Ligand exchange and colour change

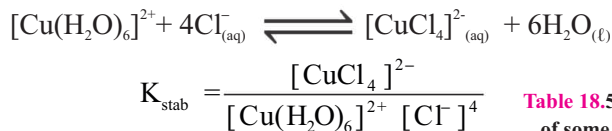
Metal ion	Initial Colour of Complex	Ligand Exchange Reaction	Final Colour of Complex
Cu^{2+}	$[\text{Cu}(\text{H}_2\text{O})_6]^{2+}$ (Blue)	Add conc. NH_3 solution	$[\text{Cu}(\text{NH}_3)_4(\text{H}_2\text{O})_2]^{2+}$ (Deep Blue)
Cu^{2+}	$\text{Cu}(\text{H}_2\text{O})_6]^{2+}$ (Blue)	Add conc. HCl solution	$[\text{CuCl}_4]^{2-}$ (Yellow/Green)
Co^{2+}	$[\text{Co}(\text{H}_2\text{O})_6]^{2+}$ (Pink)	Add conc. NH_3 solution	$[\text{Co}(\text{NH}_3)_6]^{2+}$ (Yellow)
Co^{2+}	$[\text{Co}(\text{H}_2\text{O})_6]^{2+}$ (Pink)	Add conc. HCl solution	$[\text{CoCl}_4]^{2-}$ (Blue)

**Quick Check 18.5**

- Write the equation for the reaction, where $[\text{Cu}(\text{H}_2\text{O})_4(\text{OH})_2]_s$ dissolves in excess ammonia.
- Pink $[\text{Co}(\text{H}_2\text{O})_6]^{2+}$ turns blue with conc. HCl. Explain this colour change using d-orbital splitting.
- For the reaction:** $[\text{Co}(\text{H}_2\text{O})_6]^{2+} + 4\text{Cl}^- \rightarrow [\text{CoCl}_4]^{2-} + 6\text{H}_2\text{O}$, identify the coordination number and geometry of the product complex.

18.8 STABILITY OF COMPLEXES AND STABILITY CONSTANT, K_{stab}

The stability constant (K_{stab}) is an equilibrium constant (K_c) for the formation of a complex ion. In aqueous solutions, water is the initial ligand. When we add a new ligand, it competes with water to bind with the metal ion. Let us take the example of following equilibrium complexation reaction with its K_{stab} expression;

**Table 18.5** Stability constants of some Cu(II) complexes

Concentration of water $[\text{H}_2\text{O}]$ being solvent (remains constant) is omitted from the K_{stab} expression. Stability constants are usually provided on a \log_{10} scale. This makes it easier to compare very large numbers. Higher the $\log_{10} K_{\text{stab}}$, more stable will be the complex and the equilibrium lies far to the right. And lower the $\log_{10} K_{\text{stab}}$, the complex is less stable, and the ligands can be easily displaced. The stability constant values ($\log_{10} K_{\text{stab}}$) of some copper (II) complexes are given **Table 18.5**.

Complex	$\log_{10} K_{\text{stab}}$
$[\text{CuCl}_4]^{2-}$	5.6
$[\text{Cu}(\text{NH}_3)_6]^{2+}$	13.1
$[\text{Cu}(\text{EDTA})]^{2-}$	18.8



The data shows that complexes with polydentate ligands have higher stability constant values than those with monodentate ligands. This is called chelating effect of the ligands.



A ligand with a higher K_{stab} can displace a ligand with a lower K_{stab} . For example, adding ammonia to a chloride complex will turn the solution blue because the ammonia complex is significantly more stable.



Similarly, if a stable complex is diluted with a massive amount of water, the equilibrium can be forced back to the left, re-forming the original hydrated ion.



Quick Check 18.6



- Write the K_{stab} equilibrium expression for the formation of $[\text{Cu}(\text{NH}_3)_4]^{2+}$ from $[\text{Cu}(\text{H}_2\text{O})_6]^{2+}$ and NH_3 .
- Explain why polydentate ligands form more stable complexes using K_{stab} data ($\log_{10} K_{\text{stab}}$) data for $[\text{CuCl}_4]^{2-}$ (5.6) and $[\text{Cu}(\text{EDTA})]^{2-}$ (18.8).
- Write the balanced equation for the first step of the stepwise substitution of water ligands by ammonia in $[\text{Cu}(\text{H}_2\text{O})_6]^{2+}$.

18.9 STEREOISOMERISM IN TRANSITION METAL COMPLEXES

The compounds that have the same chemical formula and bonds but differ with respect to the arrangement of ligands in space are called stereoisomers. There are two types of stereoisomerism: geometrical isomerism and optical isomerism.

18.9.1 Cis-Trans Isomerism

In these isomers, identical ligands are present at either adjacent (90° angle, cis) or opposite (180° angle, trans) positions. This is common in square planar (e.g., $[\text{Pt}(\text{NH}_3)_2\text{Cl}_2]$) and octahedral complexes (e.g., $[\text{Co}(\text{NH}_3)_4\text{Cl}_2]$).

The cis and trans isomers of $[\text{Pt}(\text{NH}_3)_2\text{Cl}_2]$ are shown in **Figure 18.11**. In *cis*- $[\text{Pt}(\text{NH}_3)_2\text{Cl}_2]$ (cisplatin), the chlorine atoms are adjacent to each other at the angle of 90° in the square complex but in *trans*- $[\text{Pt}(\text{NH}_3)_2\text{Cl}_2]$ (transplatin), they are opposite to each other at an angle of 180° . The properties of these geometrical isomers are different. It is interesting to know that cisplatin is used as an anti-cancer drug, while transplatin does not show such property.

In transplatin, the individual bond dipoles of the identical ligands are pointed in opposite direction and cancel each other, making the molecule nonpolar. In cisplatin, the similar individual bond moments do not cancel out, resulting in a non-zero dipole moment that makes it polar.

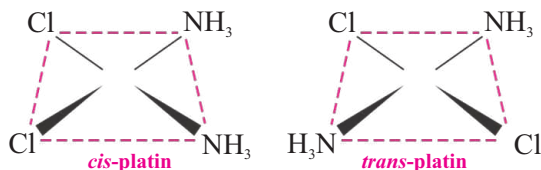


Figure 18.11 The geometrical isomers, cisplatin and transplatin



MORE INFO

Interesting Information

Cisplatin, or *cis*-diamminedichloroplatinum(II), is a landmark inorganic anticancer drug. Its discovery was accidental, found when platinum electrodes inhibited bacterial cell division. It specifically targets rapidly dividing cancer cells by entering the cell and undergoing ligand exchange, where water replaces its chloride ions. The "activated" drug then binds to guanine bases in DNA, creating cross-links that link the double helix. This structural damage prevents DNA replication, triggering programmed cell death (apoptosis).

$[\text{Co}(\text{NH}_3)_4(\text{H}_2\text{O})_2]^{3+}$ is an $[\text{MA}_4\text{B}_2]$ type octahedral complex. The *cis* and *trans* isomers of $[\text{Co}(\text{NH}_3)_4(\text{H}_2\text{O})_2]^{3+}$ are shown in **Figure 18.12**. In the *cis* isomer, the two H_2O ligands occupy adjacent positions at a 90° angle with respect to each other, while in the *trans* isomer, they occupy opposite positions at a 180° angle to each other.

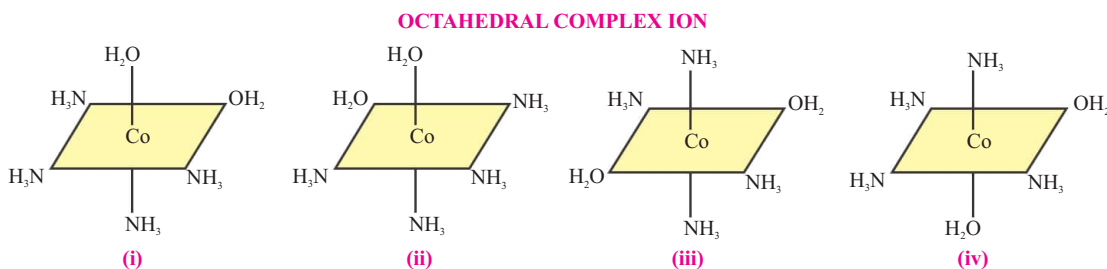


Figure 18.12 The geometrical isomers, $[\text{Co}(\text{NH}_3)_4(\text{H}_2\text{O})_2]^{3+}$

18.9.2 Optical Isomerism

Optical isomers are non-superimposable mirror images of each other. Optical isomerism is commonly shown by octahedral complexes with bidentate ligands. An example is the nickel(II) complex containing 1,2-diaminoethane ($\text{NH}_2\text{CH}_2\text{CH}_2\text{NH}_2$) as the bidentate ligand (**Figure 18.13**). The two isomers are optical isomers because the two different molecules are mirror images of each other and cannot be superimposed. Such pairs of molecules are called enantiomers. The optical isomers rotate the plane of polarized light in opposite directions. The isomer that rotates the plane in right hand direction is called dextrorotatory "+", while the one that rotates in left hand direction is called laevorotatory "-".

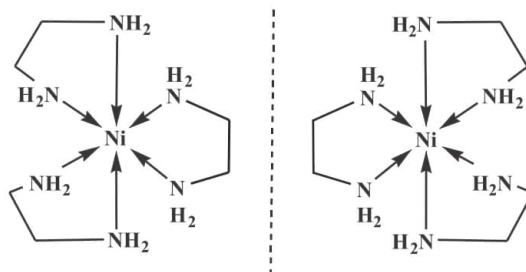


Figure 18.13 The two non-superimposable optical isomers of $[\text{Ni}(\text{en})_3]^{2+}$



**Quick Check 18.7**

- Which type of geometries shows cis-trans isomerism?
- What type of ligand is most often required for a complex to show optical isomerism?
- For the complex $[\text{Ni}(\text{en})_3]^{2+}$, state the coordination number and the type of ligand.
- Identify the type of isomerism displayed by the complex $[\text{Ni}(\text{NH}_2\text{CH}_2\text{CH}_2\text{NH}_2)_3]^{2+}$, and describe how the two different isomers interact with plane-polarized light.
- Define optical isomers (enantiomers) in terms of their mirror images and superimposability.

18.10 REDOX REACTIONS OF TRANSITION METALS

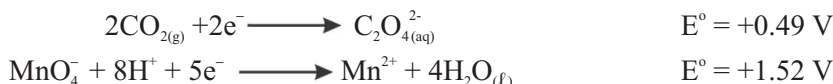
Transition elements are notable for their ability to exist in multiple oxidation states. The feasibility of a redox reaction is determined by comparing the standard electrode potentials (E°) of the half-reactions involved. A reaction is feasible if the overall cell potential (E°_{cell}) is positive.

$$E^\circ_{\text{cell}} = E^\circ_{\text{reduction}} - E^\circ_{\text{oxidation}}$$

In practice, the species with the more positive E° value will be reduced (gain electrons). The species with the more negative (less positive) value will be oxidized (lose electrons).

18.10.1 Reaction of Acidified Manganate(VII) Ions (MnO_4^-) with Ethanedioate Ions ($\text{C}_2\text{O}_4^{2-}$)

Let us take the example of the reaction between acidified MnO_4^- and $\text{C}_2\text{O}_4^{2-}$, we compare the standard reduction potentials of the two half-reactions. The half-reaction with the more positive E° value is more likely to undergo reduction (to proceed to the right). Based on the E° values, the MnO_4^- ion is more likely to be reduced to Mn^{2+} (acting as the oxidizing agent), and the $\text{C}_2\text{O}_4^{2-}$ ion must be oxidized to CO_2 (acting as the reducing agent).



The reaction with higher reduction potential is likely to occur and proceed to the right and vice versa. The given reduction potential values indicate that Mn(VII) ion should be reduced to Mn(II) acting as an oxidizing agent while oxalate must be oxidized to CO_2 and behave as reducing agent.

The number of electrons lost must be equal to number of electrons gained. It is done by multiplying the two half reactions with different coefficients. Here, oxidation half equation is multiplied by 2 and reduction half equation by 5.

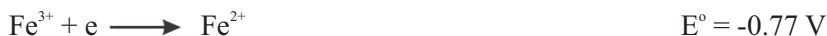
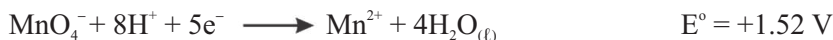


The large positive net E° value (+1.03 V) indicates that the forward reaction is feasible.

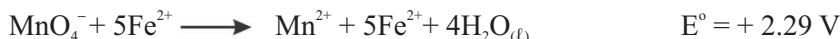
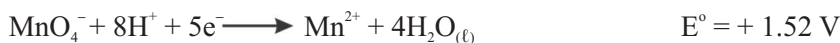


18.10.2 Reaction of Manganate(VII) Ion (MnO_4^-) with Iron(II) Ion (Fe^{2+})

This redox reaction involves the reduction of MnO_4^- and the oxidation of Fe^{2+} as indicated by the potential values. The relevant half-reactions (in reduction form) are:



Combine and balance the two equations and sum up their standard electrode potentials so that we can check feasibility of the overall reaction.



The positive value of the standard electrode potential indicates that this reaction will proceed to the right, making this reaction feasible.

18.10.3 Reaction Between Copper(II) Ion (Cu^{2+}) and Iodide Ion (I^-)

When an excess of potassium iodide is added to an aqueous solution of copper(II) sulphate, the following reaction occurs:



White ppt red-brown solution

The reaction splits into the following half-equations:



Typically, the I_2/I^- couple, with the higher E° value, would be more likely to undergo reduction. The $\text{Cu}^{2+}/\text{Cu}^+$ couple has a lower E° , suggesting Cu^+ is a better reducing agent than I^- .

However, the overall reaction proceeds forward despite a calculated **negative** net standard potential.

The reaction is driven forward because CuI formed is continuously precipitating out of the solution, which effectively removes the Cu^+ product and shifts the equilibrium to the right (Le Chatelier's principle). The amount of I_2 formed in this reaction can be quantified by titrating it with a thiosulfate solution.



Quick Check 18.8



- State the principle used to determine the feasibility of a redox reaction using standard electrode potentials (E°), as described in the text.
- For the reaction between MnO_4^- and Fe^{2+} , the relevant reduction potentials are $\text{MnO}_4^-/\text{Mn}^{2+}$ ($E^\circ = +1.52 \text{ V}$) and $\text{Fe}^{3+}/\text{Fe}^{2+}$ ($E^\circ = +0.77 \text{ V}$). Identify the oxidizing agent and the reducing agent in this specific feasible reaction.
- Explain why water is omitted when calculating the E°_{cell} for the reaction between MnO_4^- and $\text{C}_2\text{O}_4^{2-}$ ions, even though it appears in the overall balanced equation.



Exercise

Q1. Multiple Choice Questions (MCQs)

- I. Which statement about the general physical properties of the first-row transition elements (titanium to copper) is incorrect?**
- They generally have high densities.
 - They are typically soft solids at room temperature.
 - They are good conductors of heat and electricity.
 - They possess high melting and boiling points.
- II. The ability of transition elements to behave as catalysts is primarily linked to which of their properties:**
- Their high density.
 - Their ability to easily change oxidation states.
 - Their shiny surface appearance.
 - Their formation of complex ions.
- III. What is the reason for variable oxidation states in 3d transition metals?**
- High density.
 - Stable, filled 4s subshell.
 - Comparable energy of 3d and 4s subshells.
 - High ionization energies.
- IV. Which ionic configuration represents a metal that lost only its 4s electrons?**
- | | |
|---------------------------------------|----------------------------------|
| a) $\text{Ti}^{4+}([\text{Ar}])$ | b) $\text{V}^{5+}([\text{Ar}])$ |
| c) $\text{Fe}^{2+}([\text{Ar}] 3d^6)$ | d) $\text{Sc}^{3+}([\text{Ar}])$ |
- V. In the complex ion, $[\text{Fe}(\text{CN})_6]^{4-}$, what is coordination number of central metal ion?**
- | | |
|------|------|
| a) 2 | b) 4 |
| c) 6 | d) 8 |
- VI. The colour displayed by a transition metal complex is a result of electrons moving between d-orbitals. This process is called a:**
- | | |
|-------------------|------------------------------------|
| a) p-p transition | b) d-d transition |
| c) s-p transition | d) Ligand-to-metal charge transfer |
- VII. Adding excess ammonia to pink $[\text{Co}(\text{H}_2\text{O})_6]^{2+}$ gives a yellow solution. What other changes occur besides colour change?**
- Coordination number changes from 6 to 4
 - Oxidation state of Co changes from +2 to +3
 - d-orbital splitting magnitude (ΔE) changes
 - Complex becomes a precipitate



VIII. Which one of the following complex has different geometry than others?

- a) $[\text{CuCl}_4]^{2-}$
b) $[\text{Cu}(\text{H}_2\text{O})_4(\text{OH})_2]$
c) $[\text{Cu}(\text{H}_2\text{O})_6]^{2+}$
d) $[\text{Cu}(\text{NH}_3)_4(\text{H}_2\text{O})_2]^{2+}$

IX. What geometry is typical when $\text{Co}^{2+}_{(\text{aq})}$ reacts with six monodentate anionic ligands?

- a) Octahedral
b) Square Planar
c) Linear
d) Tetrahedral

X. Optical isomers are characterized by their ability to rotate plane-polarized light. The isomer that rotates light to the right is called:

- a) Laevorotatory (–)
b) Superimposable
c) Dextrorotatory (+)
d) Achiral

Q2. SHORT ANSWER QUESTIONS

- a) Why is zinc not included in the transition metals, although it shows electronic configuration with d-orbitals and also the member of d-block?
- b) What is the correlation between the ability of transition elements to exhibit variable oxidation states and their electron configuration.
- c) How do transition metals function as effective catalysts. Give some examples.
- d) Why the complex $[\text{Cr}(\text{en})_3]^{3+}$ is more stable than $[\text{Cr}(\text{H}_2\text{O})_6]^{3+}$?
- e) Define a complex and the nature of the bond between its components.
- f) What is the coordination number? Give this number for $[\text{Fe}(\text{CN})_6]^{4-}$.
- g) Define a bidentate ligand and state how many bonds it forms to the central ion.
- h) Draw the structure of EDTA ligand and label its electron pair donating sites.
- i) Draw the colour wheel used to predict the colour of transition metal complexes. Also pair up the complementary colours with each other.
- j) Define K_{stab} . How it reflects the stability of coordination complexes?
- k) How coordination number 4 has two shapes i.e., tetrahedral and square planar?
- l) Illustrate the type of isomerism shown by $[\text{Pt}(\text{NH}_3)_2\text{Cl}_2]$ complex.
- m) Give medicinal importance of cis-plantin.
- n) What happens when excess of ammonia solution is added to $\text{Co}(\text{II})$ hydroxide precipitates?
- o) Is there any effect of excessive dilution of complexes? If yes then justify how does dilution affect the position of equilibrium in ligand ion exchange reactions?

Q3. CONSTRUCTED RESPONSE QUESTIONS

- a) Discuss the two types of stereoisomerism found in transition metal complexes. Use the examples $[\text{Pt}(\text{NH}_3)_2\text{Cl}_2]$ (square planar) and $[\text{Ni}(\text{NH}_2\text{CH}_2\text{CH}_2\text{NH}_2)_3]^{2+}$ (octahedral) to illustrate the key structural differences that give rise to geometrical and optical isomerism, respectively.



- b) The reaction between Cu^{2+} and I^- results in a solid precipitate of CuI and aqueous I_2 .
- Write down the two relevant reduction half-equations and their E° values (provided in the text).
 - Explain why comparing only the E° values suggests the reaction is *not* feasible as written.
 - Use Le Chatelier's principle to explain why the reaction proceeds forward in practice.
- c) Using the examples $[\text{Co}(\text{NH}_3)_6]^{3+}$ and $[\text{Fe}(\text{CN})_6]^{3-}$, demonstrate how to predict the formula and overall charge of a complex ion. Clearly explain the role of the central metal ion charge, ligand charge, and coordination number in determining the final result for both examples.

DESCRIPTIVE QUESTIONS

- Q4. Explain the factors that determine the specific geometry (shape) of a transition metal complex.
- Q3. Describe the splitting of d-orbitals and colour formation in octahedral and tetrahedral complexes.
- Q4. Compare the reactions of conc. HCl with aqueous Cu^{2+} and aqueous Co^{2+} . Include equations, colour/geometry changes, and the reason for different colours.
- Q5. Describe the various redox reactions that takes place in transition metal complex ions?
- Q6. Explain the stereoisomerism with its types in transition metal complexes.



19

BASICS OF ORGANIC CHEMISTRY

Student Learning Outcomes

[C-12-D-01 to C-12-D-20]

- ⊙ Define catenation and explain its importance in organic chemistry.
- ⊙ Recognize that hydrocarbons are compounds made up of C and H atoms only.
- ⊙ Describe the shape of benzene and other aromatic molecules, including sp^2 hybridization, in terms of σ bonds and a delocalized π system.
- ⊙ Recognize that compounds contain a functional group which dictates their physical and chemical properties.
- ⊙ Recognize that alkanes are simple hydrocarbons with no functional group.
- ⊙ Describe the use of systematic nomenclature of simple aliphatic organic molecules with functional groups.
- ⊙ Interpret the general, structural, displayed and skeletal formulae of the classes of compounds.
- ⊙ Deduce the molecular and / or empirical formula of a compound, given its structural, displayed or skeletal formula.
- ⊙ Apply the term 'planar' when describing the arrangement of atoms in organic molecules.
- ⊙ Describe terminology associated with the types of organic compounds and reactions (some examples include: Homologous series, saturated and unsaturated, homolytic and heterolytic fission, free radical, initiation, propagation, termination, nucleophile, electrophile, nucleophilic, electrophilic addition, substitution, elimination, hydrolysis, condensation, oxidation and reduction).
- ⊙ Describe terminology associated with types of organic mechanisms (Some examples include: Free-radical substitution, electrophilic addition, nucleophilic substitution, nucleophilic addition).
- ⊙ Draw the mechanism of a chemical reaction using curly arrows to represent the movement of a pair of electrons in at least three different types of reactions, including nucleophilic substitution, electrophilic addition, and elimination reactions.
- ⊙ Describe structural isomerism (in the context of organic molecules) in its division into chain, positional, functional group isomerism, metamerism and tautomerism.
- ⊙ Explain stereoisomerism and its division into cis-trans (cis/trans) and optical isomerism.
- ⊙ Describe the effect of two optical isomers of a single substance on a plane polarised light.
- ⊙ Explain what is meant by a chiral center and that such a center gives rise to two optical isomers (enantiomers).
- ⊙ Describe that enantiomers have identical physical and chemical properties except for their ability to rotate plane-polarised light and potential biological activity.
- ⊙ Apply the terms optically active, racemic mixture and mesocompounds on given structure.
- ⊙ Describe cis-trans (cis/trans) isomerism in alkenes, and explain its origin in terms of restricted rotation due to the presence of π bonds.
- ⊙ Explain the significance of chirality in the synthetic preparation of drug molecules, including the potential different biological activity of enantiomers, the need to separate racemic mixtures, and the use of chiral catalysts to produce a single pure optical isomer using thalidomide as an example.



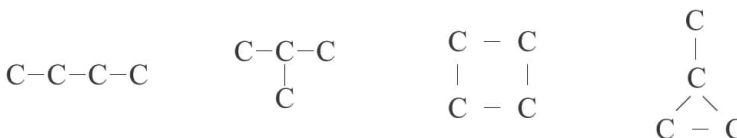
Today, we are familiar with more than 20 million carbon containing compounds. Most of these are studied in organic chemistry, which is defined by IUPAC as, “the study of compounds containing carbon, where carbon is bonded to itself, hydrogen, or other elements excluding some inorganic compounds.”

The examples of traditional inorganic compounds, which are excluded from organic chemistry are carbonates, cyanides (e.g KCl), CO_2 , CO, etc. Organic compounds can be easily distinguished from inorganic compounds by their unique properties, such as low m.p's, b.p's, low densities and low solubility in water.

19.1 CATENATION

The ability of self-linkage between the atoms of the same element is known as catenation (from the Latin: *Catena-Chain*). Carbon forms long chains and rings through the stable C – C covalent bonds. The self-linking property of carbon atoms has unique importance in organic chemistry.

Tetravalent nature of carbon enables it to have much more different ways of arrangements to give a variety of compounds. For example, with four carbon atoms, there are four different arrangements.



Catenation explains why organic compounds are complex, having large structures and vast diversity.



Quick Check 19.1

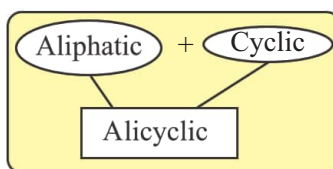


- Draw the different possible structures containing five carbon atoms.
- Give different open chain structures containing six carbon atoms.

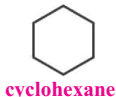
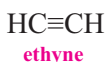
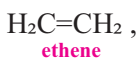
19.2 HYDROCARBONS (COMPOUNDS OF CARBON AND HYDROGEN ONLY)

Compounds containing carbon and hydrogen only in their molecules are called hydrocarbons. On the basis of carbon skeleton, hydrocarbons are broadly classified into two types:

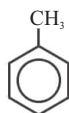
- Hydrocarbons possessing open chain of carbon atoms are called open chain or acyclic hydrocarbons, or more commonly aliphatic hydrocarbons (aleiphatos is a Greek word meaning fat; fats have open chain structure). These can be further subdivided into saturated hydrocarbons (alkanes) or unsaturated hydrocarbons (alkenes and alkynes).



- a) Hydrocarbons possessing rings of carbon atoms are called closed chain or cyclic hydrocarbons. These can be further divided into two types;
- Some cyclic hydrocarbons both saturated and unsaturated which behave like aliphatic hydrocarbons, are called alicyclic hydrocarbons e.g, cycloalkanes, cycloalkenes etc.
 - Some cyclic hydrocarbons having benzene ring or resembling structures are called aromatic hydrocarbons, e.g., benzene, naphthalene, diphenyl methane etc.

Aliphatic hydrocarbons

benzene

Aromatic hydrocarbons

methyl benzene



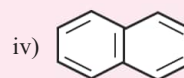
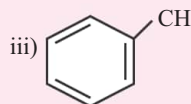
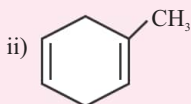
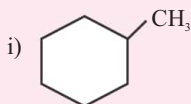
naphthalene



anthracene

**Quick Check 19.2**

- a) Classify the following compounds as an aliphatic, alicyclic or aromatic.



v)

vi)

vii) **19.3 FUNCTIONAL GROUPS**

An atom or group of atoms or presence of double or triple bond which determines the characteristic properties of an organic compound is called functional group. Both physical and chemical properties of organic compounds are highly affected by the nature of functional groups they possess.

Methanol and ethanol are liquids while methane and ethane are gases. Likewise, m.p and b.p of alcohols are higher than their corresponding alkenes. These properties are due to the presence of the hydroxyl functional group (-OH) in alcohols. The alcohol functional group has the ability to form the hydrogen bonding. Alkanes lack this ability as they have no such functional group in their molecules. Similarly, lower alcohols and carboxylic acids, glucose and sucrose etc., are soluble in polar solvents like water due to their polar functional groups.

The types of organic compounds are dictated by the following factors in their functional groups:

- Polarity of the bond
- Bond order i.e. number of bonds in the functional group

Alkanes and cycloalkanes have no functional group in them as they do not possess any charges or polarity, or double and triple bonds in their structures.



19.4 NOMENCLATURE OF ALIPHATIC ORGANIC COMPOUNDS

Since, millions of organic compounds are found in nature and hundreds and thousands of new compounds are being synthesized every year, so a need was felt to name these compounds according to their structures. A set of rules was thus formulated by IUPAC (International Union of Pure and Applied Chemistry) for systematic nomenclature of organic compounds. The systematic or IUPAC name of an organic compound is based on the parent hydrocarbon. Each name consists of the components listed below.

i) Stem or Root

It gives the longest continuous carbon chain including the carbon bearing the functional group. Lowest possible number is given to the carbon bearing the functional group. If the carbon atoms are joined in a ring, the name is started by “cyclo”.

ii) Suffix

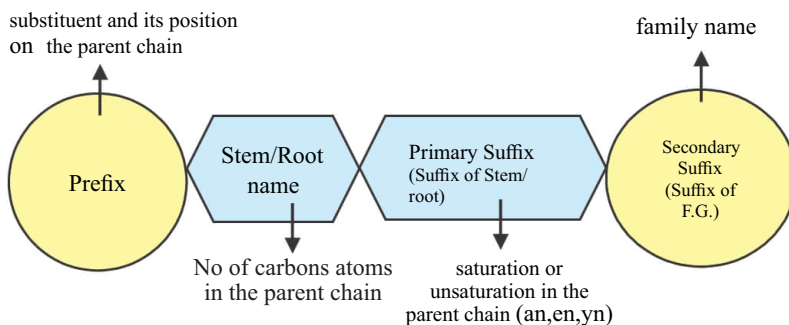
There are two types of suffixes:

a) Primary suffix, also called suffix of stem or root. It indicates whether the parent chain is saturated or unsaturated.

b) Secondary suffix, also called suffix of the key functional group. It gives family name of the compound.

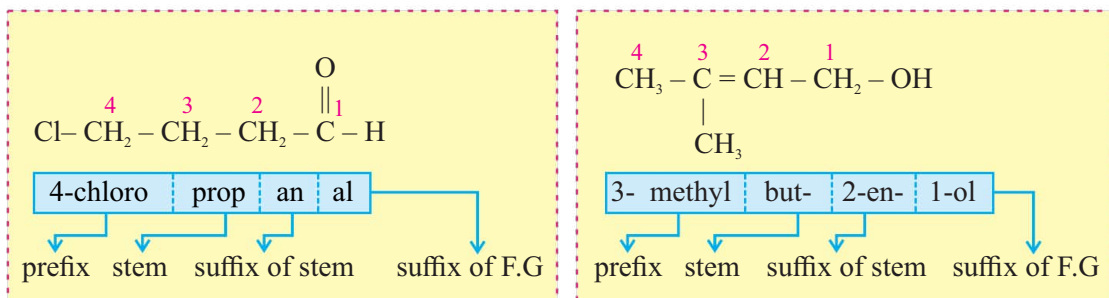
iii) Prefix

It gives the name of the side chain (alkyl group) or any substituent (e.g. some functional group like halo, nitro, etc.) along with number of carbon atom to which it is attached.



If prefix is absent, then systematic name will consist of root and suffix.

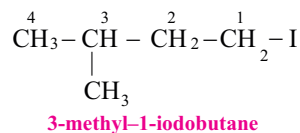
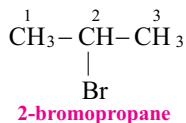
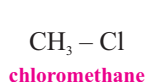
Examples:



Keeping in view, the above procedure for giving systematic or IUPAC names to various organic compounds, following different classes will be discussed one by one:

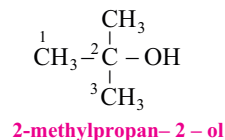
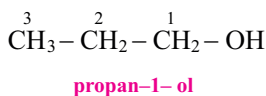
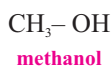
1. Alkyl halides ($C_nH_{2n+1}X$) $(-C-X)$

The IUPAC name is halogenoalkane (more precisely monohaloalkane)



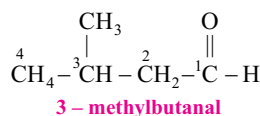
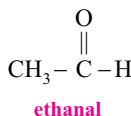
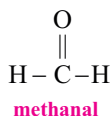
2. Alcohols ($C_nH_{2n+2}O$) $(-C-OH)$

The IUPAC name is alkanol.



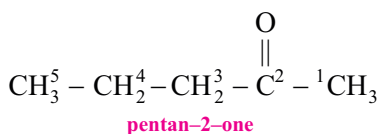
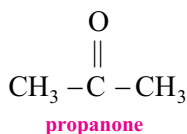
3. Aldehydes ($C_nH_{2n}O$) $(-C(=O)-H)$

The IUPAC name is alkanal.



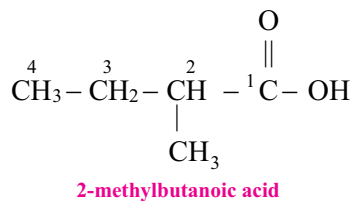
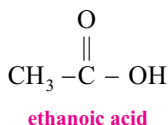
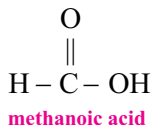
4. Ketones ($C_nH_{2n}O$) $(-C(=O)-C-C-)$

The IUPAC name is alkanone



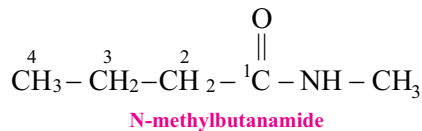
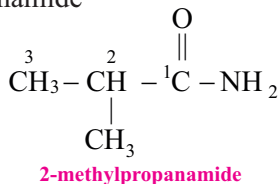
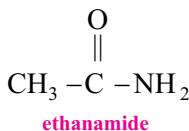
5. Carboxylic acid ($C_nH_{2n}O_2$) $(-C(=O)-OH)$

The IUPAC name is alkanonic acid



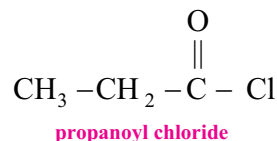
6. **Acid amides** ($C_nH_{2n-1}ONH_2$) $(-\overset{\text{O}}{\parallel}{C}-NH_2)$

The IUPAC name is alkanamide

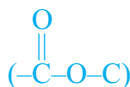


7. **Acid halides** ($C_nH_{2n-1}OX$) $(-\overset{\text{O}}{\parallel}{C}-X)$

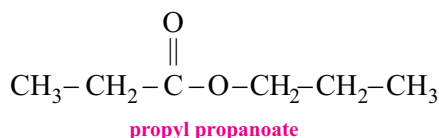
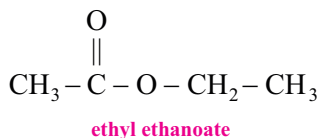
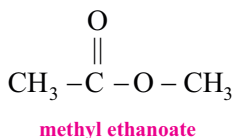
The IUPAC name is alkanoyl halides



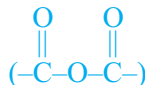
8. **Esters** ($C_nH_{2n}O_2$)



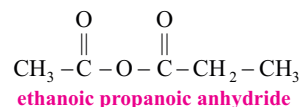
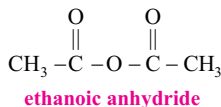
The IUPAC name is alkyl alkanoate



9. **Acid anhydrides**

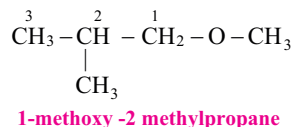
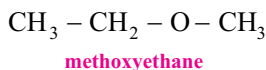
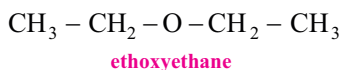
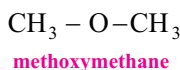


The IUPAC name is alkanic anhydride



10. **Ethers** ($C_nH_{2n+2}O$) $(-\text{C}-\text{O}-\text{C}-)$

The IUPAC name is alkoxyalkane.



11. Amines ($C_nH_{2n+1}NH_2$)

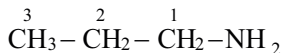
There are three types of amines

a) Primary Amines ($-C-NH_2$)

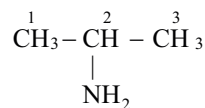
The IUPAC name is **Alkanamine**



ethanamine



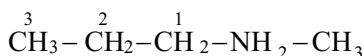
propan-1-amine



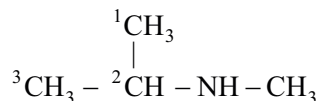
propan-2-amine

b) Secondary Amines ($-C-NH-R$)

The IUPAC name is **N-Alkylalkanamine**



N-methylpropan-1-amine



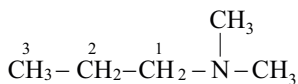
N-methylpropan-2-amine

c) Tertiary amines ($-C-N-R$)

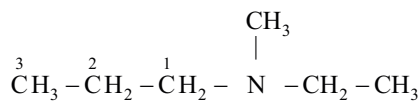
The IUPAC name may be (R=R) $\underset{\substack{| \\ R}}{N}$

N,N - Dialkylalkanamine or

(R≠R) N - alkyl - N - alkylalkanamine



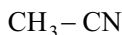
N,N - dimethylpropan-1-amine



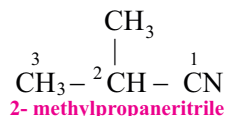
N-ethyl - N-methylpropan-1-amine

12. Alkyl cyanides ($C_nH_{2n-1}N$) ($-C\equiv N$)

The IUPAC name is **alkanenitrile**



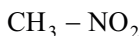
ethanenitrile



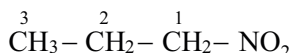
2-methylpropanenitrile

13. Nitroalkanes ($C_nH_{2n+1}NO_2$) ($-C-NO_2$)

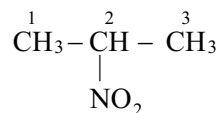
The IUPAC name is **nitroalkane**



nitromethane



nitropropane



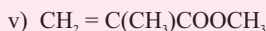
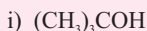
2-nitropropane



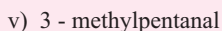
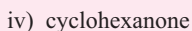
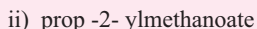
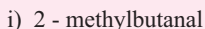
Quick Check 19.3



a) What are the systematic names of the following?



b) Draw the structures of the following.



19.5 REPRESENTING ORGANIC MOLECULES

There are different types of formulae which are used to represent organic compounds.

1. Molecular Formula

“The formula which represents the actual number of atoms of each element present in a molecule of a compound is called molecular formula.”

For example, molecular formula of butane is C_4H_{10} , for acetic acid $C_2H_4O_2$ and that of ethanol is C_2H_6O . However, molecular formula gives no information about the sequence in which atoms are linked together as well as the nature of a functional group. That is why two different compounds may have the same molecular formula e.g. ethanol and methoxymethane are represented by same molecular formula i.e; C_2H_6O .

2. Empirical Formula

The formula which represents the smallest whole number ratio of atoms of each element present in a molecule of a compound is called empirical formula. For example, empirical formula of butane (C_4H_{10}) is C_2H_5 , and for ethanoic acid (acetic acid, $C_2H_4O_2$) is CH_2O .

3. Structural Formula

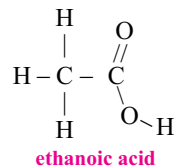
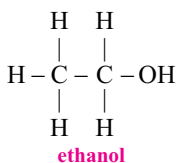
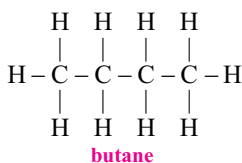
The structural formula not only shows the number of each kind of atom in the molecule but also the sequence in which atoms are joined together.

There are different types of structural formulae.

(a) Displayed formula (Graphical formula)

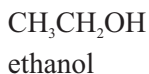
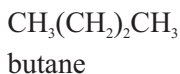
This formula is more complete and self-explanatory form of the structural formula.

“The formula which shows all the bonds between different atoms including the type of bonds as well as positions of functional groups in a molecule is called the displayed formula.”



a) Condensed formula (Linear Formula)

Displayed formula uses a lot of space, it is very often condensed in to a one – line structure called condensed or linear formula. In this kind of formula, single covalent bonds are omitted, however, branches, functional groups, double or triple bonds and separating methylene groups in the middle of the molecule are shown in brackets e.g.

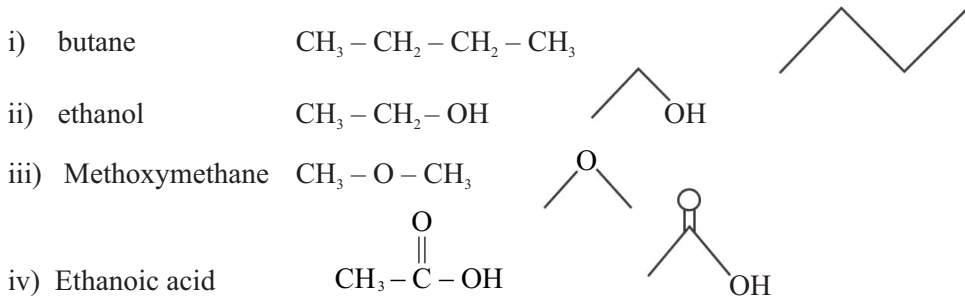


b) Skeletal Formula (Bond-line Formula)

Skeletal formula is the simplified version of displayed formula which can be used to represent more complex organic molecules.



In skeletal formula, all the symbols of carbon and hydrogen atoms as well as the carbon to hydrogen bonds are removed. Bonds between carbon atoms are shown by single lines which meet at an angle. Each carbon is assumed to form enough C – H bonds to make a total of four bonds. Double and triple bonds as well as functional groups are shown in the skeletal formula. For example:



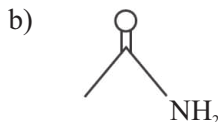
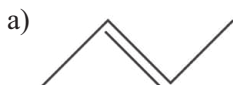
Quick Check 19.4



- Draw the displayed and skeletal formulae of the following
 - 3,5- diethylheptane
 - 2-bromo-3,3-dichlorohexane
 - 2 – methylbutanal
- Draw the displayed and condensed structures of ethanol and methoxy methane, and explain whether they are isomers of the same molecule or not.
- Draw the skeletal formula of ethanoic acid (CH_3COOH).

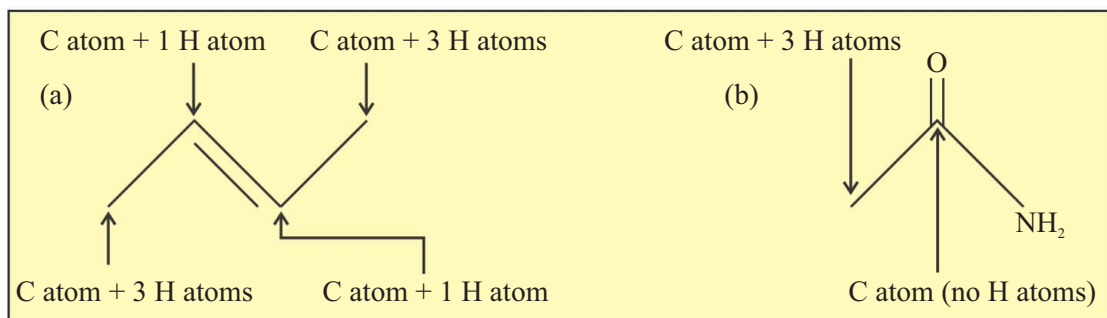
19.6 DETERMINATION OF THE MOLECULAR FORMULA

Let us write the molecular and empirical formulae for the following compounds.



Steps to find molecular formula

- Count the C atoms represented and the heteroatoms shown in the skeleton.
- Each line represents a bond and each joint shows a carbon atom. (Double lines represent double bonds). Count one C atom at the end of each line unless another atom is shown there.
- Count the number of H atoms necessary to complete the octet of each C atom:



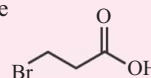
- Solution :** a) Molecular formula: C_4H_8 ; Empirical formula: CH_2 .
 b) Molecular formula: C_2H_5NO ; Empirical formula: CH_3CONH_2 .



Quick Check 19.5

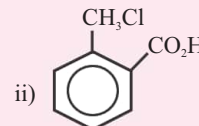
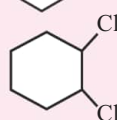


- a) Write molecular formula for the compound represented by the following bond-line structure:



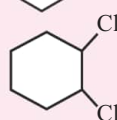
- b) Draw the skeletal formula for $(CH_3)_2C=CHNH_2$

- c) Write molecular formula for the compound represented by the following bond-line structure:

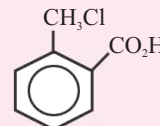


- d) Give the molecular formulae of the following.

i)



ii)



19.7 UNDERSTANDING ORGANIC REACTIONS

Since chemical reactions of organic compounds are complex in nature, therefore, in order to have a deep insight into their chemistry, we proceed further by keeping in view the following basic statements:

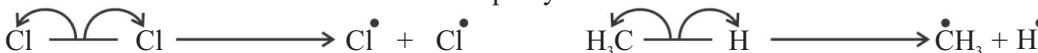
- There are two ways in which a covalent bond can break, i.e. homolytic and heterolytic
- There are basically three types of reagents, i.e. free radicals, electrophiles, and nucleophiles.
- There are four generally types of organic reactions.

A. Breaking of Covalent Bonds

There are two ways in which covalent bonds can break:

I. Homolytic Fission (Homolysis)

Homolytic fission occurs when the breaking bond is nonpolar. In this type of fission, the two shared electrons in the bond are distributed equally between the two atoms.



The dot (.) beside each atom indicates the unpaired electron that the atom has gained from the shared pair in the bond.

“These atoms or groups of atoms with unpaired electrons are called free radicals.”

Free radicals are formed when a nonpolar bond is broken. These free radicals are the reaction intermediates and are highly reactive because of the tendency of their unpaired electrons to be paired.

ii. Heterolytic Fission (Heterolysis)

In this type of fission, the two shared electrons in the bond are distributed unequally between the two atoms. One of the atoms keeps both electrons, and it acquires a negative charge. The other atom is deficient in one electron and, thus, acquires a positive charge.

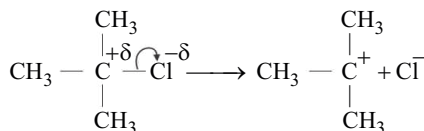
Heterolytic fission occurs when the breaking bond is polar.



iii. Carbocation Formation

A species which contains a carbon atom with a positive charge is known as carbocation:

Carbocation is formed when carbon is bonded to a heteroatom whose electronegativity is more than carbon e.g; O, N, S, P etc.



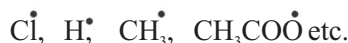
Carbanion is formed when carbon is bonded to a heteroatom (metal) whose electronegativity is lesser than carbon e.g. Li, Mg, Cd etc.

B) Types of Reagents

A chemical reaction between two reactants may be regarded as the attack of one species on the other. In this case, the attacking species is called reagent and the species which is undergoing attack is called the substrate.

i. Free Radical

An atom or group of atoms having unpaired electrons are called free radicals e.g.

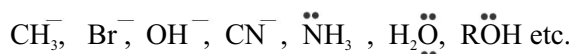


ii. Electrophile

An atom or group of atoms that is able to accept a pair of electrons to form a new bond is called an electrophile. Electrophiles (electron lovers) are either positive ions (including carbocations) or neutral molecules e.g. CH_3^+ , H^+ , Br^+ , NO_2^+ , SO_3 , BF_3 , etc.

iii. Nucleophile

An atom or group of atoms that is able to donate a pair of electrons to form a new bond is called nucleophile. Nucleophiles (nucleus lovers) are either negative ions (including carbanions) or neutral molecules e.g.



The terms electrophilic and nucleophilic do not apply only to ions. Many organic compounds are polar; they carry partial charges, which can also make them electrophilic or nucleophilic.



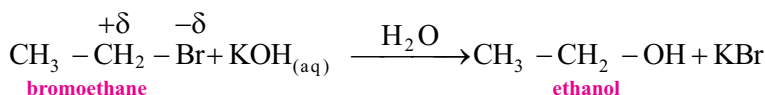
C. Types of Organic Reactions

The reactions of organic compounds can be classified into four main types:

i. Substitution Reactions

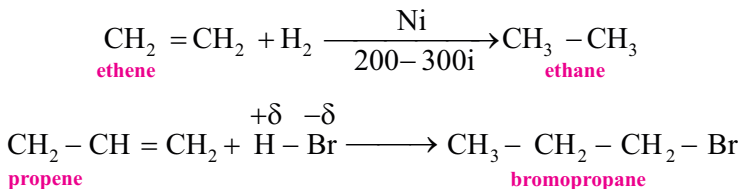
In substitution reactions, two reactants react in such a way that an atom or group of atoms in one molecule is replaced by another atom or group of atoms. Two products may be formed. For example:





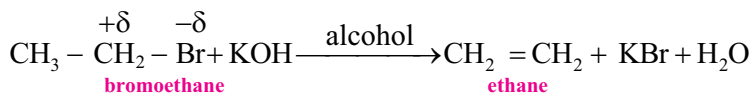
ii. Addition Reactions

In addition reactions, two reactants react to produce a single product. For example:



iii. Elimination Reactions

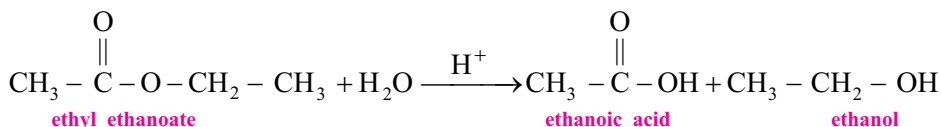
In elimination reactions, removal of atoms or groups of atoms from two adjacent atoms in the substrate molecule occurs to form a multiple bond. For example:



Elimination reactions are regarded as reverse of addition reactions.

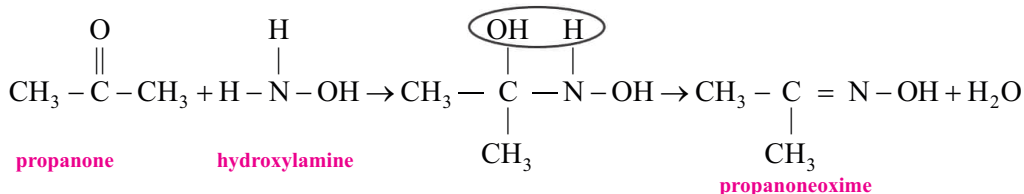
iv. Hydrolysis

In hydrolysis, a compound breaks into two on reaction with water often helped by H^+ or OH^- as catalyst. For example,



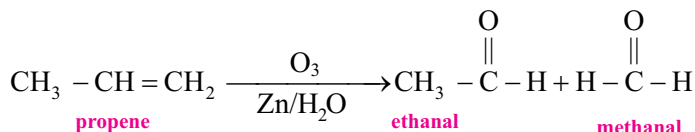
v. Condensation Reactions

In condensation reactions two molecules combine to form a bigger molecule with or without loss of a smaller molecule like H_2O , NH_3 , HCl etc. For example,



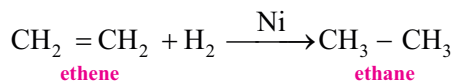
vi. Oxidation

Loss of electron is called oxidation. Moreover, if a molecule gains oxygen or loses hydrogen or there is increase in number of bonds of carbon with oxygen or increase in oxidation state of carbon, it is oxidized.



vii. Reduction

Reduction is a reaction where gain of electron, loss of oxygen or gain of hydrogen, or a decrease in the number of bonds of carbon with oxygen or decrease in oxidation state of carbon occurs.

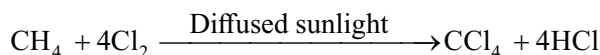
**19.8 MECHANISMS OF CHEMICAL REACTIONS**

A mechanism is the pathway adapted by a reaction showing the breaking and making of bonds in the substrate leading to the formation of the product. Depending upon the nature of reagents, reaction mechanisms are divided into two main types.

- 1) Free radical mechanism
- 2) Ionic or polar mechanism

1) Free Radical Mechanism

It involves homolysis during which free radicals are produced which attach the substrate molecule e.g.



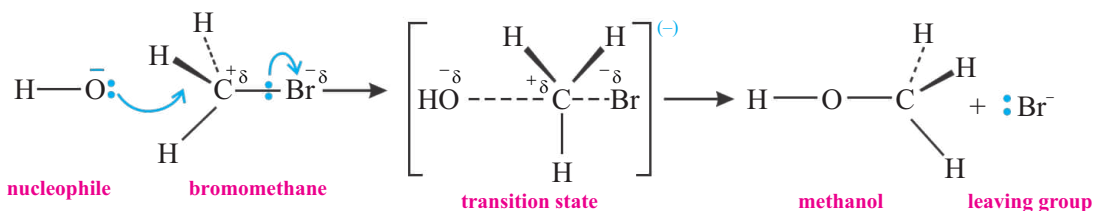
This reaction proceeds through the free radical mechanism, which was already discussed in Chemistry 11. The reaction involves initiation where initial free radicals are produced. These radicals generate more radicals in the propagation step. Finally, the reaction terminates by combining the free radicals of the same or different types.

**1) Ionic or polar mechanism**

It involves heterolysis, during which electrophiles and nucleophiles are produced, which may attack polar substrate molecules. The polar mechanism is further divided into the following types.

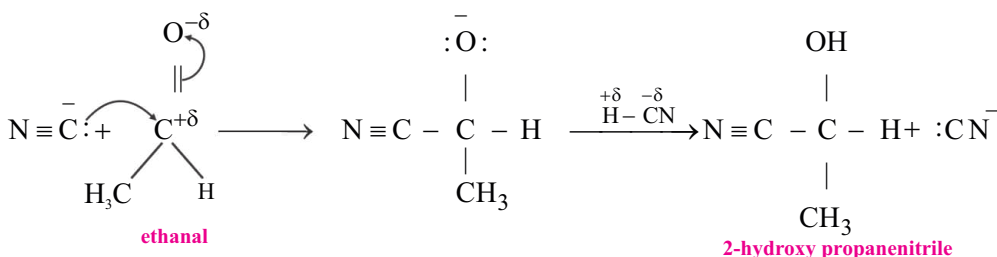
i) Nucleophilic Substitution Reactions

In this type of reaction, a nucleophile attacks on a saturated electrophilic carbon and substitutes another nucleophile called leaving group e.g.

**ii) Nucleophilic Addition Reactions**

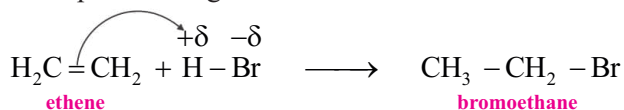
In this type of reactions, a nucleophile attacks on electrophilic carbon of a carbonyl compound to give addition product e.g.





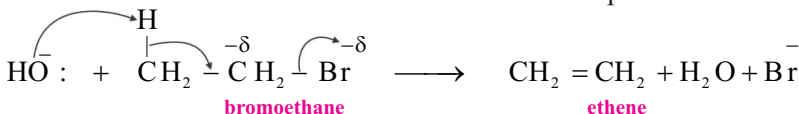
iii) Electrophilic Addition Reactions

In this type of reaction, an electrophile attacks on an electron rich position (nucleophilic) like carbon-carbon double or triple bond e.g.



iv) Elimination Reactions

In this type of reaction, two atoms or groups are removed from two adjacent carbon atoms in molecule. The removal results in the formation of a double or triple bond.



Quick Check 19.6



- Describe each of the following as electrophile, nucleophile or free radical.
 - NH_3
 - Br
 - H_2O
 - NO_2^{\oplus}
 - $\text{Cl}^{\delta\oplus}$
- Classify each of these reactions as addition, substitution, elimination or rearrangement.
 - $\text{CH}_3\text{CH} = \text{CH}_2 + \text{HBr} \longrightarrow \text{CH}_3\text{CHBrCH}_3$
 - $\text{CH}_4 + \text{Br}_2 \longrightarrow \text{CH}_3\text{Br} + \text{HBr}$
 - $\text{CH}_3\text{CH}_2\text{CHClCH}_3 \longrightarrow \text{CH}_3\text{CH}_2\text{CH} = \text{CH}_2 + \text{HCl}$
- Classify the following reactions into one (or more) of the following six categories: Substitution, addition, hydrolysis, reduction, condensation, oxidation.
 - $(\text{CH}_3)_2\text{C} = \text{O} + \text{H}_2\text{N} - \text{NH}_2 \longrightarrow (\text{CH}_3)_2\text{C} = \text{N} - \text{NH}_2 + \text{H}_2\text{O}$
 - $\text{CH}_3\text{CHO} + 2[\text{H}] \longrightarrow \text{CH}_3\text{CH}_2\text{OH}$

19.9 ISOMERISM

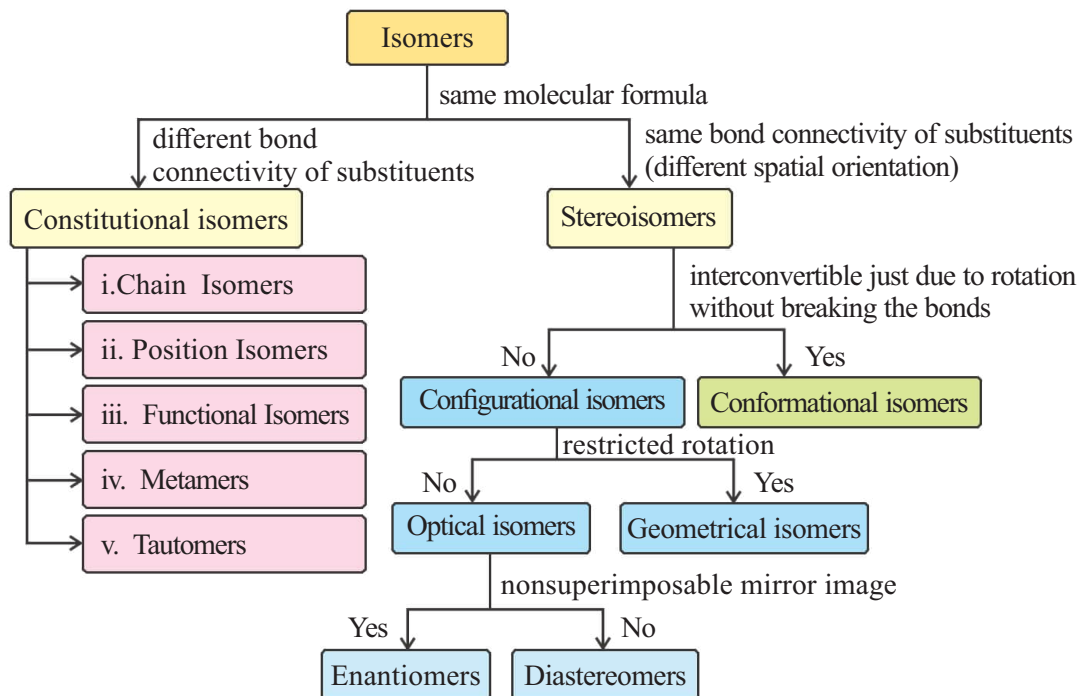
Two or more than two compounds which have same molecular formulae but different arrangement of atoms and different properties are called isomers and the phenomenon is called isomerism.

The isomerism of organic compounds stems from the two distinct features.

- When same groups or atoms are connected at different places in two or more molecules, it results in structural or constitutional isomerism. This type of isomerism has been discussed earlier in Chemistry 11.



2. When the substituents or groups have different spatial arrangement in isomers, they are said to have different configuration. This type of isomerism is called stereoisomerism.



19.9.1 Stereoisomerism

Stereoisomers are further divided into two types.

- a) Optical isomers
- b) cis-trans isomers

Optical Isomers are the stereoisomers which have identical physical and chemical properties except their ability to rotate the plane polarised light. Such isomers are said to be optically active and this property of these isomers of rotating the plane of polarization is called optical activity. Optical activity of a compound is identified by using plane polarised light (PPL). If the compound rotates the plane of polarised light to right (clockwise), it is called dextrorotatory indicated by symbol (+) and if it rotates the plane to left (anticlockwise), it is called levorotatory indicated by the symbol (-).

Keep in Mind



A polarimeter is used to identify and measure quantitatively the optical activity of a compound by using PPL. PPL is a monochromatic light having single wavelength which moves only in one plane. A solution of the compound under investigation is placed before PPL. If the compound rotates the PPL, it is optically active and if not, it is optically inactive.



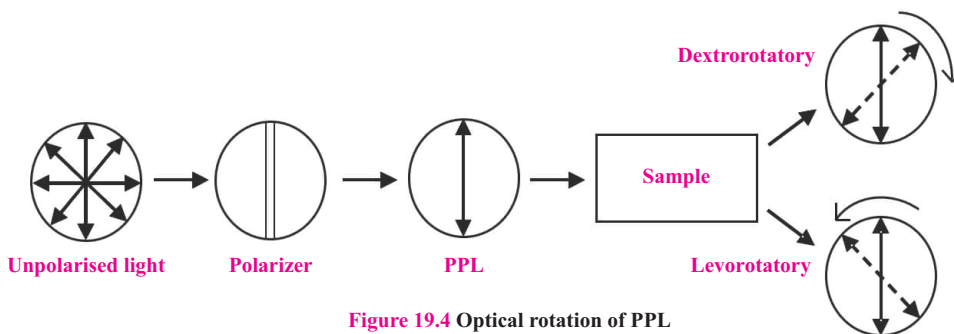


Figure 19.4 Optical rotation of PPL

Optical activity and the structure of a compound

The basic requirement for a compound to be optically active is that it is non-superimposable on its mirror image. This condition is fulfilled by asymmetric/chiral molecules. It can be understood by considering an analogy of our right and left hands, which are non-superimposable as in **Figure 19.5**. The word 'chiral' is from a Greek word 'Cheir' which means hand. Hence, chirality is also called handedness.

Molecules which are superimposable on their mirror images are achiral and they are optically inactive.

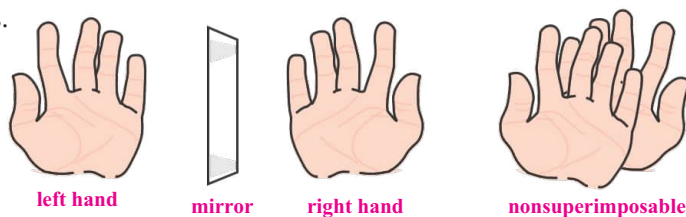
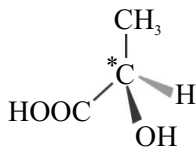
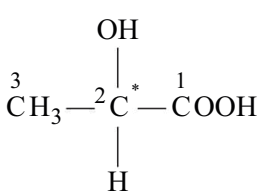


Figure 19.5 Our hands are non-superimposable on their mirror images.

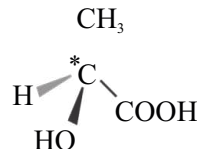
A carbon atom bearing four different atoms or group of atoms is called chiral carbon. Any organic molecule which is not symmetric and it rotates the plane polarised light is a chiral or asymmetric molecule. If a molecule has only one chiral carbon atom, it is always asymmetric and hence optically active. However, if there are more than one chiral atoms, a molecule may or not be asymmetric and optically active.

Enantiomers

If a molecule has only one chiral carbon atom, it is always chiral and hence optically active. For example consider the structure of lactic acid. It has a chiral carbon (indicated by an asterisk) bonded to four different groups, i.e., CH_3 , H, OH and COOH.



(-) lactic acid



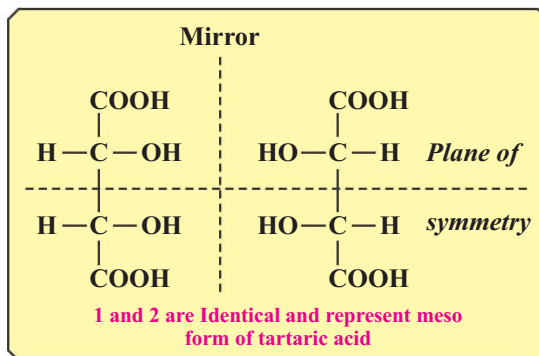
(+) lactic acid



Its three dimensional structure shows that it has two stereoisomers which are non-superimposable mirror image of each other and are called enantiomers ('enantio' means opposite). The **enantiomers** have identical physical and chemical properties but they rotate the plane of polarised light in opposite directions, with the same extent. One enantiomer is, therefore, dextrorotatory (+) and the other is levorotatory (-). When 50% dextrorotatory and 50% levorotatory enantiomers are present, they form an optically inactive mixture. Such a mixture is called a racemic mixture. A racemic mixture is symbolized by placing symbol (\pm) in front of the name of the compound. Thus, lactic acid exists in two different optically active forms i.e, (+) lactic acid, (-) lactic acid and an inactive racemic mixture (\pm).

Meso Isomers

The stereoisomers which contain at least two similar chiral carbon atoms and also possess a plane of symmetry are optically inactive. The plane of symmetry divides the molecule into two equal halves, one half of the molecule being mirror image of the other half. The two halves will rotate the plane of polarised light in opposite direction. As a result, rotation of one half of molecule is internally compensated (cancelled) by the other half and the molecule will become optically inactive. Such stereo isomers are called meso forms. Tartaric acid is the classic example of this phenomenon.



Maximum number of optical isomers of an optically active compound is given by the formula 2^n , where 'n' is the number of chiral carbon atoms. This number is reduced, however, if there are two or more similar chiral carbon atoms.



Quick Check 19.7



Q1: Classify the following objects as chiral or achiral.

- (a) Pencil (b) Book (c) Shoe (d) Cup
(e) Ear (f) Foot (g) Egg (h) Spoon

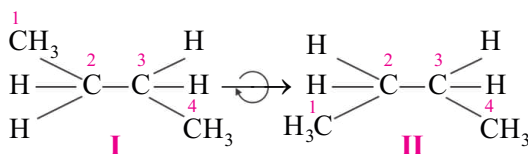
Q2: Glucose and fructose are two monosaccharides.

- How many chiral carbon atoms are there in glucose and fructose?
- Calculate the possible number of optical isomers of glucose and fructose.
- Is there any meso form in glucose or fructose? Give reason.

19.9.1 Cis-trans Isomerism

The stereoisomers having different spatial arrangement of atoms due to restricted rotation about a double bond in open chain compounds are called cis-trans isomers.

First of all we consider free rotation about C-C single bond in butane.



In butane, forms I or II are called conformational isomers because they are interconvertible into each other due to free rotation of the C-C single bond. They cannot be separated at room temperature.



When the C-C single bond between C-2 and C-3 atoms rotates, the methyl groups also rotate and structure I changes in II and II back into I due to this free rotation.

Now, consider but-2-ene $\overset{1}{\text{CH}_3} - \overset{2}{\text{CH}} = \overset{3}{\text{CH}} - \overset{4}{\text{CH}_3}$ in which both carbon atoms 2 and 3 are sp^2 hybridized. The C-C double bond consists of a σ bond formed by the linear overlap of sp^2 hybrid orbitals and a π bond formed by the parallel overlap of p orbitals. The presence of π bond locks the molecule in one position. The two carbon atoms C-2 and C-3 of the double bond and all the groups attached to them lie in the same plane and their position in space is fixed. For free rotation around the C-C double bond, π bond should be broken first. It requires energy equal to 263 kJ/mol, which is not possible at room temperature. The rotation about C-C double bond is therefore restricted. This restriction of rotation about the C-C double bond is responsible for the cis-trans isomerism (**Figure 19.6**).

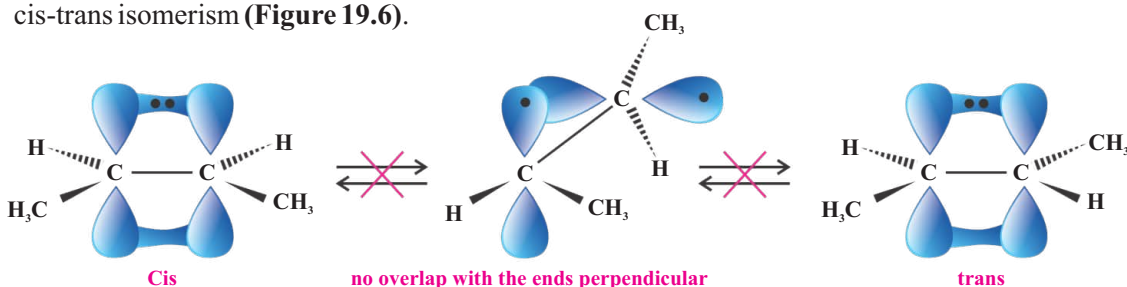
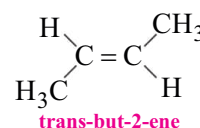
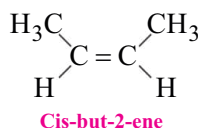
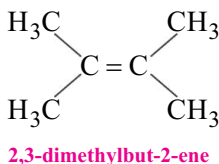
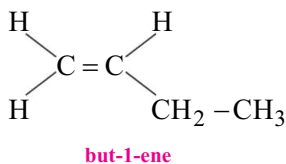


Figure 19.6 The two isomers of but-2-ene cannot interconvert by rotation about the C-C double bond without breaking the π bond

Now the above structures can be considered as cis-trans isomers and named as follows.



The cis isomer is one in which two similar groups are on the same side of the double bond. The trans isomer is that in which two similar groups are on the opposite side of the double bond. It is important to note that cis-trans isomerism will not be possible, if one of the unsaturated carbon atom is bonded to two identical groups. For example:



Each of the above two compounds does not show cis-trans isomerism.

“Thus for an open chain compound the necessary and sufficient condition to show cis-trans isomerism is that, it should have double bond in its molecule and that two different groups must be attached to each of the doubly bonded carbon atoms.”

KEEP IN MIND

The cis-trans isomers have different physical and chemical properties. The trans isomers are more stable than the corresponding cis isomers and hence differ in chemical reactivity. Similarly, both types of isomers have different physical properties like melting point, boiling point, dipole moment, density, heat of vapourisation etc.



19.10 STEREOCHEMISTRY IN DRUG DEVELOPMENT

In the synthesis of pharmaceutical products chirality is a critical feature to determine safety and efficacy. Because biological systems are composed of chiral building block drug receptors which function as highly specific “chiral locks”. Consequently, the two enantiomers of a chiral drug often exhibit vastly different potentials and profiles. Thalidomide, a tranquilliser was originally distributed as racemic mixture

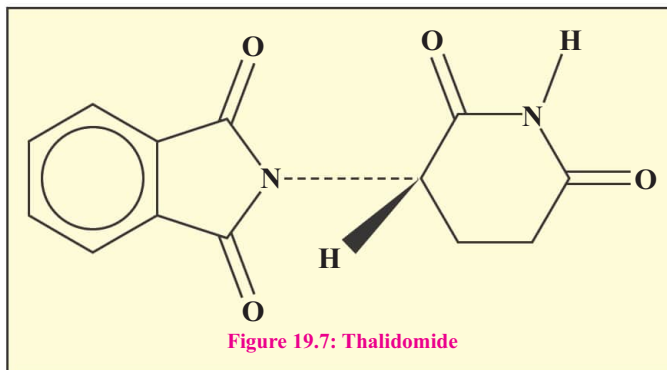


Figure 19.7: Thalidomide

It seemed to be a very successful, non-toxic sedative with no known side-effects. In the early 1960s, however, it was discovered that women who had been prescribed the sedative to treat the nausea ('morning sickness') in early pregnancy had produced badly deformed babies. The drug was immediately withdrawn.

Research showed that whilst the (+) isomer was an effective and safe tranquilliser, the (-) isomer was the culprit in damaging the fetus. Originally it was thought that the problem had been due to contamination by the (-) isomer in some production batches, but subsequent research has shown that racemisation of the pure (+) isomer occurs rapidly as soon as it enters the blood stream. Within 10 minutes racemisation is over 50% complete. Thalidomide will never be marketed again, although analogues, that are chirality stable are being, investigated as possible anti-inflammatory drugs.

Exercise

Q1. Multiple Choice Questions (MCQs):

I) Which of the following is organic in nature?

- | | |
|------------------|-------------------|
| a) CO_2 | b) CS_2 |
| c) HCN | d) CCl_4 |

II) The empirical formula of $\text{CH}_3\text{CH}_2\text{CH}=\text{CH}_2$ matches with:

- | | |
|---|--------------------------------|
| a) CH_3CH_3 | b) $\text{CH}_2=\text{CHCH}_3$ |
| c) $\text{CH}_3\text{CH}_2\text{CH}_2\text{CH}_3$ | d) $\text{CH}\equiv\text{CH}$ |

III) Compounds having single bonds usually undergo reactions:

- | | |
|-----------------|--------------------------------------|
| a) addition | b) elimination |
| c) substitution | d) both elimination and substitution |

IV) The functional group present in urea ($\text{H}_2\text{N}-\overset{\text{O}}{\parallel}{\text{C}}-\text{NH}_2$) is:

- | | |
|-------------|-----------------|
| a) carbonyl | b) amino |
| c) amide | d) all of these |



- iv) 2-aminopropanoic acid
- c) What is the alkane of lowest relative molecular mass that contains a chiral centre? Give its systematic name and molecular formula. Also draw mirror image of this compound.
- d) 3-chlorobutan-2-ol is an optically active compound. Draw all its possible optical isomers. Is there any meso form of this compound? Give reason.

DESCRIPTIVE QUESTIONS

- Q4. Explain the difference between homolytic and heterolytic fissions of a covalent bond.
- Q5. Discuss cis-trans isomerism. Explain with two examples.
- Q6. Describe the phenomenon of optical activity. Explain with an example.
- Q7. What is the difference between racemic mixture and meso compound? Draw the structures of enantiomers and meso form of lactic acid.



20

AROMATIC
HYDROCARBONS

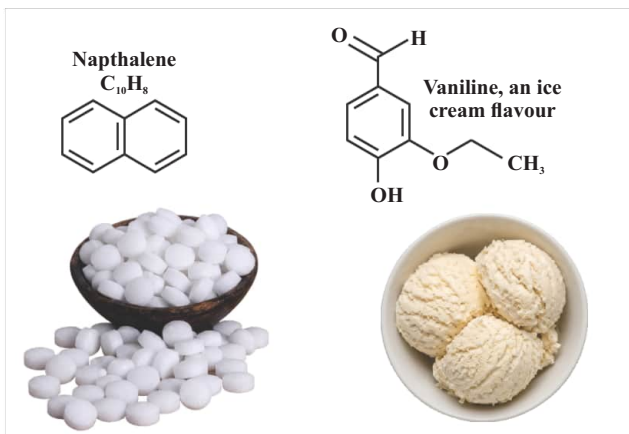
Student Learning Outcomes

[C-12-D-21 to C-12-D-29]

- Explain the shape of the benzene molecule (molecular orbital aspect).
- Define resonance, resonance energy and relative stability of benzene.
- Compare the reactivity of benzene with alkanes and alkenes.
- Describe the mechanism of substitution reactions with chlorine and bromine, including the formation of ortho, para, and meta isomers, and predict the major product(s) of the reaction.
- Explain the mechanism of nitration, including the formation of a neutronium ion, and predict the major product(s) of the reaction.
- Explain the mechanism of Friedel-Crafts alkylation and acylation, respectively, including the role of the Lewis acid catalyst, and predict the major product(s) of the reaction.
- Explain the mechanism of side chain oxidation, including the formation of benzoic acid, and predict the major product(s) of the reaction.
- Explain the mechanism of hydrogenation, including the role of a metal catalyst, and predict the major product(s) of the reaction, which is cyclohexane.
- Describe the mechanism of electrophilic aromatic substitution, including the role of the electrophile and the formation of a sigma complex, and predict the major product(s) of the reaction based on the directing effects of substituents on the aromatic ring.

Benzene is one of the most important organic compounds with the chemical formula C_6H_6 . It is the simplest aromatic hydrocarbon. **Benzene** derived products are well known to be **pleasantly fragrant**. For this reason, organic compounds containing benzene rings were classified as being “**aromatic**” (**sweet smelling**) amongst scientists in the early 19th century. Many **aromatic** compounds are **sweet/pleasant smelling**, such as **vanilla**. Organic hydrocarbons

containing one or more benzene rings are known as **arenes**. However, the term '**aromatic**' continues to be used today in order to designate molecules with benzene and benzene-like rings in their structures that are not good-smelling, rather have foul smells.





Did You Know?

Saying that only aromatic compounds smelling good and sweet is wrong. Non-aromatic compounds, such as camphor, extracted from the camphor laurel tree, release a strong, minty aroma, yet it lacks the benzene ring in its structure.



20.1 STRUCTURE OF BENZENE

After the discovery of benzene, its molecular formula was found to be C_6H_6 . Following this, many scientists attempted to figure out its structure. Some scientists presented linear structures. But, these were soon rejected as they could not explain the properties of benzene.

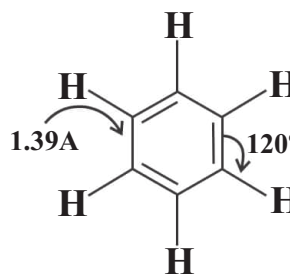
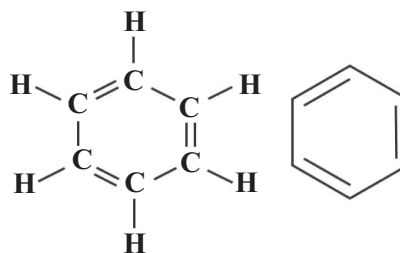
The structure of benzene remained a mystery until 1865 when a German professor August Kekule elucidated it as a six membered cyclic compound having alternate single and double bonds as below.

Kekule structure of benzene

This structure explained many properties of benzene successfully.

There were, however, a number of problems with Kekule's structure in that it didn't fully explain the physical and chemical properties of benzene.

X-ray studies of benzene exhibits a planar configuration characterized by a regular hexagon comprising six sp^2 hybridized carbon atoms. As illustrated, each carbon atom is connected to three additional atoms with bond angles of 120° for C–C–C and H–C–C. The length of the C–H bond is 109 pm, while the length of the C–C bond is 139 pm, falling between the single bond lengths of sp^3 hybridized carbons (154 pm) and sp^2 hybridized carbons (133 pm). All C–C and C–H bond lengths are 1.3970 Å and 1.090 Å, respectively.



Bond angles and bond lengths in benzene

20.1.1 Thermodynamic Stability of Benzene and Resonance

Benzene like alkenes have double bonds, however it is much more stable than alkenes. Evidence of the increased stability of benzene is obtained by measuring the heat emitted during the hydrogenation of benzene and cyclic alkenes. These heats of hydrogenation can be related to the relative thermodynamic stability of the compounds. This reaction yields cyclohexane as a common product via catalytic addition of hydrogen. In the following diagram, cyclohexane symbolizes a low-energy reference point. Let us analyse the heats of hydrogenation of different cyclohexenes.



The hydrogenation of cyclohexene results in the formation of cyclohexane and releases 120 kJ mol^{-1} of energy. From this, we could expect that cyclohexadiene would yield 240 kJ mol^{-1} on complete hydrogenation, while the hypothetical 1,3,5-cyclohexatriene would produce 360 kJ mol^{-1} as shown in **Figure 20.1**.

Following this, we must expect that heat of hydrogenation of benzene would be much higher if it were a

cyclohexene too. Its heat of hydrogenation would be equal to the hypothetical cyclohexatriene as shown in the above diagram. Benzene, however, has much lower heat of hydrogenation (208 kJ mol^{-1}) exhibiting an exceptional stability. This heat is $158.5 \text{ kJ mol}^{-1}$ lower than expected. It shows benzene is much more stable than the hypothetical cyclohexatriene.

This stability is explained based on the delocalisation of π electrons. According to the modern concept, all the benzene π electrons are delocalised over the ring through the π orbital overlap on all the six carbon atoms. The actual heat of hydrogenation of benzene is 152 kJ mol^{-1} lower than the theoretical value. This energy is called the resonance energy (delocalisation energy) of benzene. This concept of delocalisation is explained in the next topic (20.1.2)

20.1.2 Atomic Orbital Structure of Benzene

The hexagonal frame work of benzene ring can be conveniently explained by using hybridization approach. According to this, each carbon atom in benzene is sp^2 hybridized. The three sp^2 hybrid orbitals on each carbon are utilized to form three σ -bonds, two with adjacent carbon atoms and one with a hydrogen atom. Since all the sp^2 orbitals are in the same plane, therefore, all the carbon and hydrogen atoms of this σ framework are coplanar at 120° .

The six unhybrid '2p' orbitals, one from each carbon, are perpendicular to this sigma framework and parallel to each other overlap sideways to form a π -electron cloud above and below the plane of the benzene ring making it a conjugated molecule. Due to this overlap six electrons are shared equally among all the six carbons and this is known as delocalization of π electron.

This delocalization causes all the six C - C bond lengths to be same (139 pm). Benzene is thus represented as a hexagon with a circle inscribed, where the circle represents delocalized π electrons.

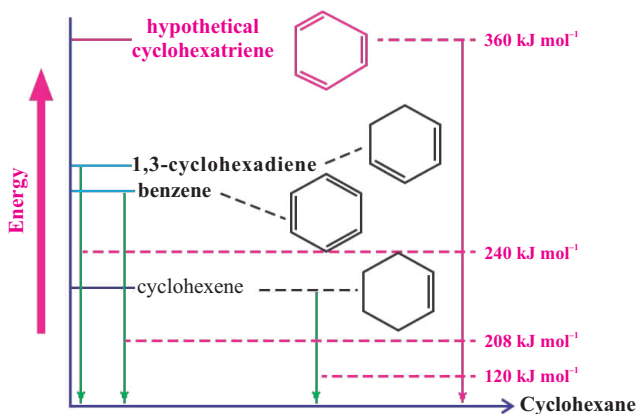


Figure 20.1 Energy level diagram of hydrogenation of cyclohexenes and benzene

Table: 20.1

Bond	Bond Length
C - C	154 pm
C = C	133 pm
C \equiv C	120 pm



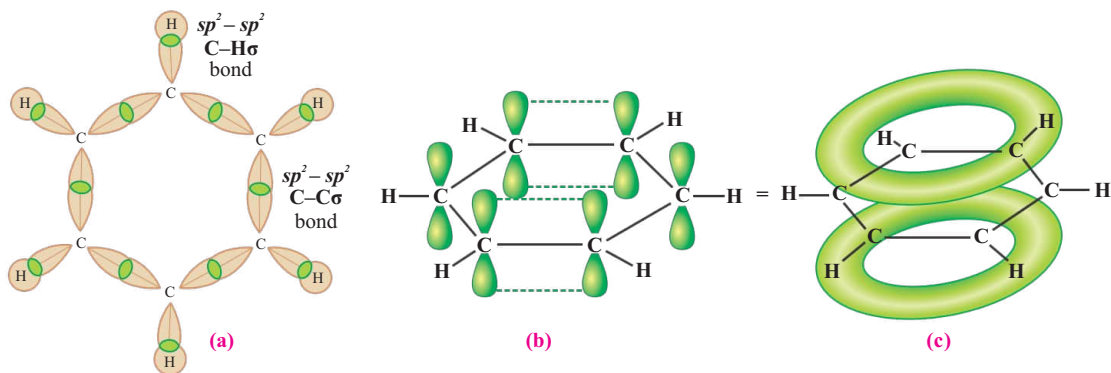


Figure 20.1 (a) σ -framework (b) π -bond formation (c) delocalized π -bond



Quick Check 20.1



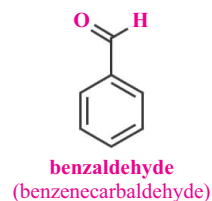
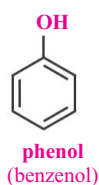
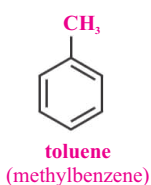
- The delocalization (resonance) energy of benzene is about 152 kJ mol^{-1} . Explain what that means and how it affects the reactivity of benzene.
- The X-ray studies show that benzene has a planar structure. If benzene were not planar, what difference in the reactivity of benzene would be seen?
- Why all the bonds in the benzene ring are of equal bond length?
- How the atomic orbital concept explains the delocalization of π electrons in benzene?

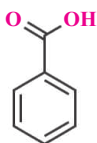
20.2 NOMENCLATURE OF BENZENE DERIVED COMPOUNDS

Aromatic hydrocarbons that contain only one benzene ring in this structure are known as **monocyclic aromatic hydrocarbons**. We will look into nomenclature of monocyclic aromatic compounds first. There are two styles of naming benzene derivatives. One in which the compound is named with the suffix 'benzene' and one with no benzene (special name).

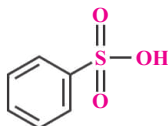
When a single substituent is present on a benzene, it is a **monosubstituted benzene**.

- Most of the monosubstituted benzenes are named with the base name 'benzene' and using the substituent group as a prefix, such as chlorobenzene, nitrobenzene and methyl benzene.
- Many monosubstituted benzenes have common names; some of these names have been included in IUPAC nomenclature as base names for the structure. e.g, phenol, toluene, aniline, etc. Common names in bold face given below are considered to be IUPAC correct base names for structures. The substituent in a monosubstituted benzene is always at C-1, so there is no need to number its location.
- Some benzene derivatives have special names, which are accepted as IUPAC names, e.g., benzene carboxylic acid, benzene sulphonic acid, etc.

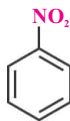




benzoic acid
(benzenecarboxylic acid)



benzene sulphonic acid



nitrobenzene



chlorobenzene

Common names of monosubstituted benzenes.

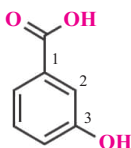
Disubstituted benzenes are compounds when two substituents are present on the benzene ring. They are named according to the following rules.

The carbon to which a higher priority substituent is attached is C_1 . Others are numbered accordingly. The order of priority of substituents (left to right) is:

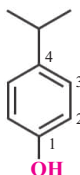


If both substituents are the same priority then the carbon having a substituent lower in alphabets is designated as C_1 .

The following examples explain how the disubstituted benzenes are named.



3-hydroxybenzoic acid
acid is higher priority
than alcohol.



4-isopropylphenol
(4-(1-methylethyl)-phenol)
The phenol alcohol is C-1



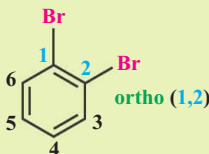
1-bromo-2-chlorobenzene
bromo is before chloro in
the alphabet

Names of disubstituted benzenes

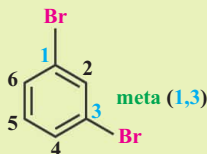


Did You Know?

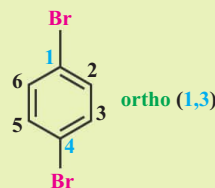
Disubstituted benzenes have common names with reference to the relationship between the two substituents. Instead of using numbers to indicate substituents on a benzene ring, *ortho*- (*o*-), *meta*- (*m*-), or *para*- (*p*-) can be used in place of positional markers when there are **two** substituents on the benzene ring.



ortho (1,2)



meta (1,3)

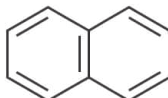


ortho (1,3)

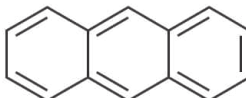
Ortho, meta and para positions of benzene

Aromatic hydrocarbons that contain two or more benzene rings in their molecules are known as **polycyclic aromatic hydrocarbons**.

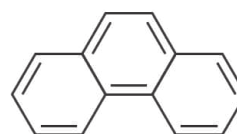
Naphthalene



Anthracene



Phenanthrene



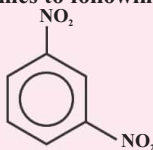
Example of polycyclic benzenes



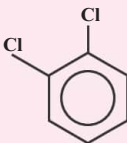
**Quick Check 20.2**

Give names to following arenes:

i)



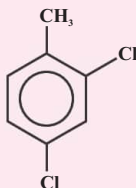
ii)



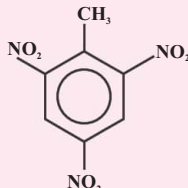
iii)



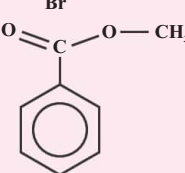
iv)



v)



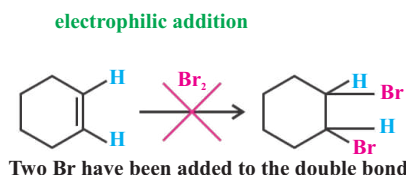
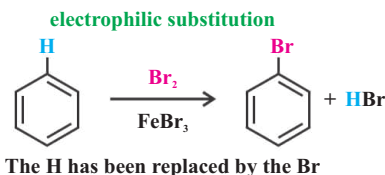
vi)

**20.3 COMPARISON OF REACTIVITY OF BENZENE WITH ALKANES AND ALKENES:**

Alkanes are generally an unreactive class of organic compounds due to their non-polar nature and the presence of sigma bond only. However, they undergo free radical substitution reactions in the presence of UV light quite easily. Alkenes, on the other hand, are very reactive class of organic compounds due to the presence of π bond and the availability of π electrons for electrophilic reagents. They undergo electrophilic addition reactions easily.

Benzene has three π bonds and, as expected, shows some similarities to alkenes in being reactive towards electrophilic species. However, there are two key differences between their reactions with electrophiles:

- benzene is very stable and thus less reactive.
- Unlike alkenes, it undergoes the electrophilic substitution and not electrophilic addition reactions:



Bromine in the electrophilic substitution reaction replaces a hydrogen atom. This is due to the stability of the aromatic ring which is due to extensive delocalization of π electrons. Even though the reaction in benzene goes through an intermediate where the aromaticity is broken, it is restored after the completion of the reaction. Therefore, electrophilic substitution does not affect the overall stability of the benzene ring. In electrophilic addition the delocalisation is broken and addition is not favourable.

**Quick Check 20.3**

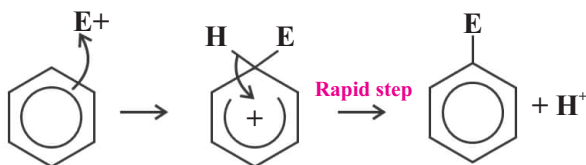
Although benzene is highly unsaturated yet it does not prefer to undergo addition reactions. Explain.



20.3.1 Electrophilic Aromatic Substitution

Regardless of electrophile used, the electrophilic aromatic substitution mechanism can be divided into three main steps.

- Generation of electrophile:** The first step of an electrophilic substitution reaction involves the generation of an electrophile. The electrophile can be a positive ion or the positive end of a polar molecule. Typically, electrophiles cannot simply be added to the reaction mixture. The electrophile is produced in situ, by adding appropriate reagents to the reaction mixture.
- Electrophilic attack:** In the second step the π electrons of benzene attack the electrophile. This forms a sigma bond between one carbon atom of the benzene ring and the electrophile. This disrupts the aromaticity in the ring as there are now only four π electrons and there is a positive charge spread over the five carbon atoms. Because of the new sigma bond formed, this intermediate is called a **sigma complex**.
- Restoration of aromaticity:** In the 3rd step, the hydrogen on the sp^3 -hybridized carbon is removed by a counterion/conjugate base restoring the aromaticity to the ring. This happens by **heterolytic cleavage** of the C-H bond. This means that the electrons in this bond go into the benzene π bonding system, and the d-localisation in the ring is restored



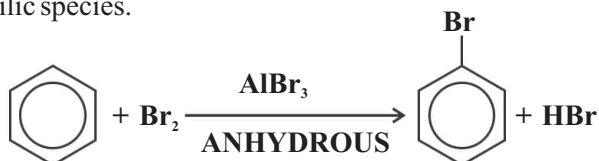
General mechanism of electrophilic substitution

Examples of electrophilic substitution reactions of arenes are given as follows.

Halogenation of Benzene

Benzene only reacts with bromine and chlorine in the presence of Lewis acids as they coordinate to the halogens and generate strong electrophilic species.

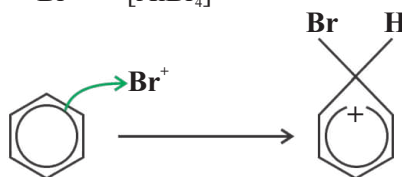
The Lewis acids are usually aluminum chloride ($AlCl_3$), iron chloride ($FeCl_3$) or iron bromide ($FeBr_3$).



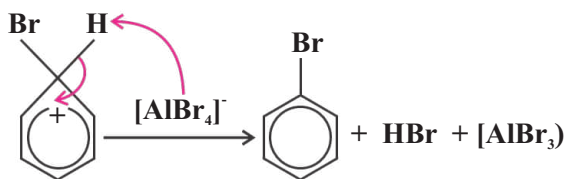
This is bromination of benzene, which involves following steps:



Once the electrophile is formed, it follows the same general mechanism as we have discussed earlier.



First, the addition of the electrophile, forming the sigma complex which is then deprotonated by AlCl_4^-



In the same way, FeCl_3 is used as the Lewis acid activator for generating Cl^+ . The rest of the mechanism is identical to what we saw for the bromination of benzene.



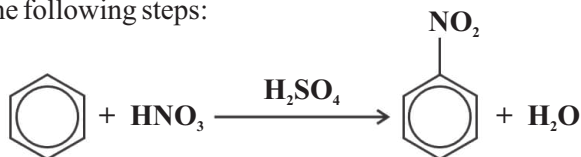
Quick Check 20.4



- a) Write mechanism of reaction of benzene with chlorine using AlCl_3 as catalyst.

Nitration of Benzene

Nitro group is introduced on benzene, using mixture of conc. HNO_3 and conc. H_2SO_4 . The mechanism involves the following steps:



- The electrophile NO_2^+ ion is generated by reacting concentrated **nitric acid** (HNO_3) and **concentrated sulphuric acid** (H_2SO_4).
- A pair of electrons from the benzene ring is donated to the NO_2^+ electrophile to form a covalent bond causing a loss in aromaticity
- The C-H bond of the substituted carbon atom breaks and the electrons go back into the benzene π bonding system, restoring its aromaticity

Mechanism:

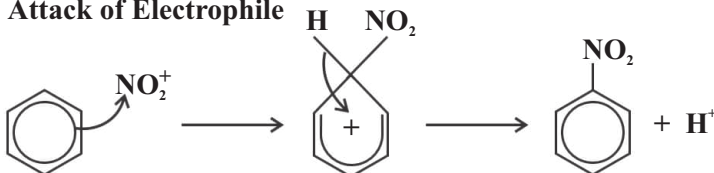


Formation of Electrophile

electrophile



Attack of Electrophile



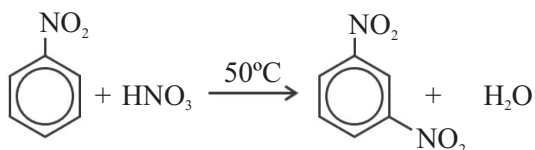
Regeneration of the Catalyst

catalyst



Concentrated sulphuric acid acts as a catalyst so is not written in the equations. At higher temperatures there is a greater chance of getting more than one nitro group substituted onto the ring. You will get a certain amount of 1,3-dinitrobenzene formed even at 50°C .



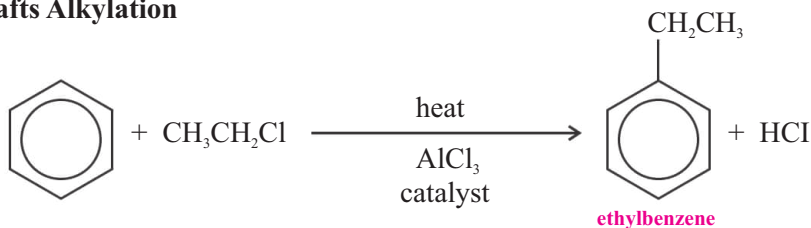

Quick Check 20.5


Show how the electrophile is produced in the nitration of benzene from sulphuric acid and nitric acid. Which of these two acts as an acid and which acts as a base?

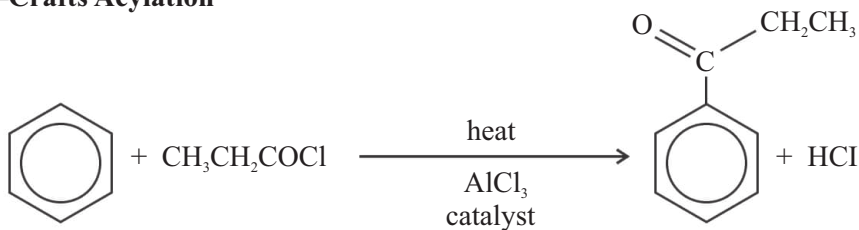
Friedel-Crafts Alkylation and Acylation

In the Friedel-Crafts acylation reaction, an **acyl group** is substituted into the benzene ring in the presence of a Lewis acid catalyst. An acyl group is an alkyl group attached to a carbonyl group, R-C=O. In the Friedel-Crafts alkylation, an **alkyl group** is substituted into the benzene ring.

Friedel-Crafts Alkylation



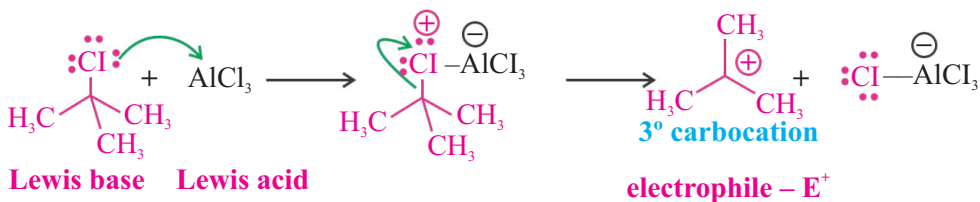
Friedel-Crafts Acylation



a) Friedel-Crafts Alkylation

The Friedel-Crafts alkylation reaction proceeds via a three-step mechanism.

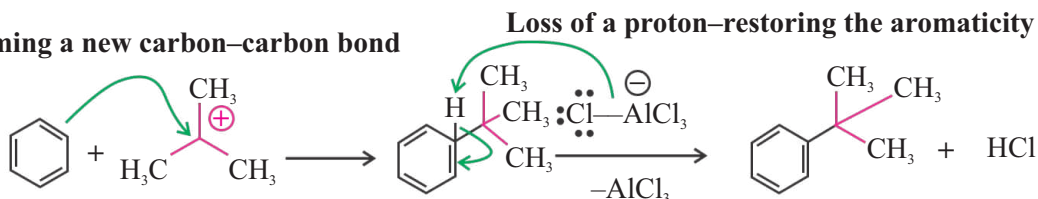
- The Lewis acid catalyst (AlCl_3) undergoes reaction with the alkyl halide, resulting in the formation of a carbocation which acts as an electrophile.



- The π electrons of aromatic ring attack on electrophilic carbocation, forming an arenium ion as an intermediate. The aromaticity of the arene is temporarily lost due to the breakage of the carbon-carbon double bond.
- The deprotonation of the intermediate leads to the reformation of the carbon-carbon double bond, restoring aromaticity to the compound. This proton goes on to form hydrochloric acid, regenerating the AlCl_3 catalyst.



Forming a new carbon–carbon bond



Addition of the electrophile

resonance structure

b) Friedel-Crafts Acylation

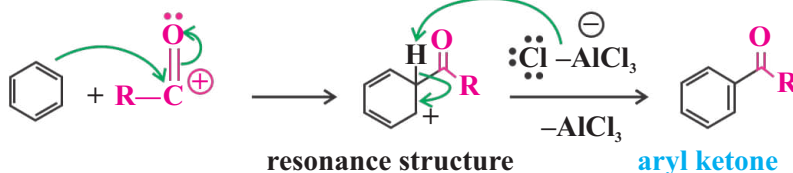
Friedel-Crafts acylations proceed through a four-step mechanism.

- 1. A reaction occurs between the Lewis acid catalyst (AlCl_3) and the acyl halide. A complex is formed and the acyl halide loses a halide ion, forming an acylium ion.



- 2. An electrophilic attack of π electrons of the aromatic ring on the acylium ion (RCO^+) takes place.

- 3. The intermediate complex is now deprotonated, restoring the aromaticity to the ring. This proton attaches itself to a chloride ion, forming HCl . The AlCl_3 catalyst is regenerated. Thus, the required acyl benzene product is obtained via the Friedel-Crafts acylation reaction.



Quick Check 20.6



1. Write down reactions of methyl benzene with bromine in the presence of AlBr_3 .
2. Explain the difference in the reactivity of bromine with benzene and with phenol. Include the type of reaction, the products that form, and any conditions required. Mechanisms for the reactions are not required.
3. Explain the difference in the reactivity of bromine with benzene and with ethyl benzene. Include the type of reaction, the products that form, and any conditions required. Mechanisms for the reactions are not required.
4. Which of 1,1-dimethylethylbenzene and methyl benzene is easier to form by Friedel-Craft reaction? Explain based on the stability of carbocation.

20.4 ORIENTATION IN ELECTROPHILIC SUBSTITUTION REACTIONS

Any group attached with benzene ring affects the electrophilic substitution reaction and determines the orientation of the substitution. There are two ways in which various substituents “direct” electrophilic aromatic substitution of incoming electrophile to benzene ring.

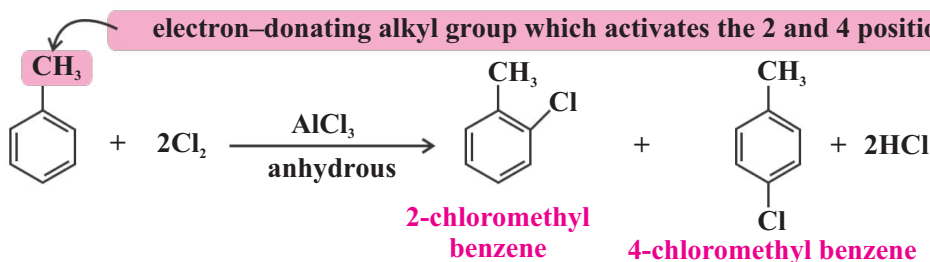
Ortho-Para Directing Groups (Activating Groups):

A group that makes the ring more reactive than benzene and influences the incoming electrophile to attach on -ortho and -para positions only, is called as -ortho, -para director. Substituents direct



the reaction to give either the “*ortho*” (1,2) or “*para*” (1,4) product, with a slight preference for “*para*”. In this pattern, *ortho*- and *para*- products dominate, and the *meta*- product is an extremely minor byproduct. Examples of *ortho*-, *para*- directors are -SR, -R, -OH, -OR, -NR₂, -SH. Note that these are groups that have the ability to donate electrons to the benzene ring.

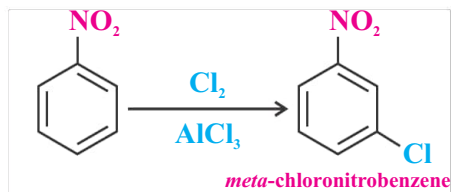
The chlorination in the methyl benzene ring takes place in the presence of **aluminium chloride** (or aluminum bromide if you are using bromine) or iron, and in the **absence of UV light**. The reactions take place at room temperature. Methyl group is 2,4-directing (o-p directing), which means that incoming groups will tend to go into the 2 or 4 positions on the ring. With chlorine, substitution into the ring gives a mixture of 2-chloromethylbenzene and 4-chloromethylbenzene.



With bromine, you would get the equivalent bromine compounds. Like methyl group on benzene ring, OH group is also ring activator so incoming groups will tend to go into the 2, 4 & 6 positions on the ring.

Meta Directing (Deactivating) Groups:

Group that makes the ring less reactive than benzene, and directs the incoming electrophile to attack on meta position only is called as meta director. Such groups are mostly electron-withdrawing groups, that destabilize the arenium intermediate. These substituents direct the reaction to give primarily the “*meta*” (1,3) product. Major product formed in this case is meta substituted. Examples of *meta*- directors include -CN, C=O, -NO₂, -CO₂-. Nitrobenzene contains a meta directing group (-NO₂), its chlorination occurs at the meta position.



Quick Check 20.7



- Explain why phenol can be nitrated using milder conditions than for benzene.
- How would you prepare 3-chloronitrobenzene from benzene?
- Which products are expected to form in majority when the following are nitrated with conc. sulphuric acid and nitric acid? Give reactions
 - benzaldehyde
 - chlorobenzene
 - phenol
 - Benzene carboxylic acid

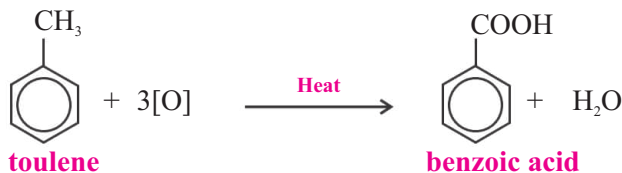
20.4.1 Combustion

When benzene is burnt in excess of air, it is completely oxidized to CO₂ and H₂O. However, this reaction gives a smoky flame which is used as a test for aromatic compounds.



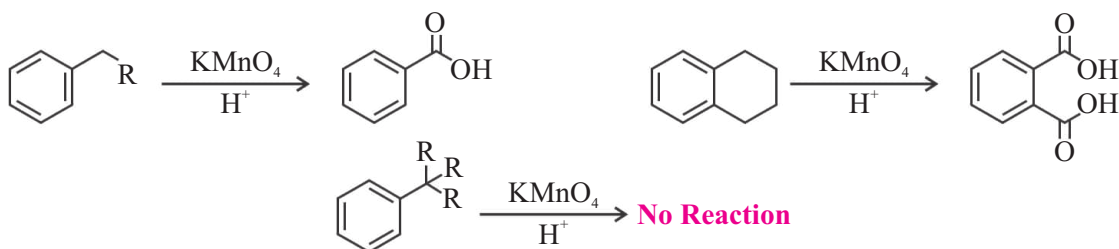
20.4.2 Side Chain Oxidation in Benzene

Oxidation reaction that takes place at an alkyl group directly attached to a benzene ring is termed as side-chain oxidation. In this reaction, alkylbenzenes are readily oxidized by alkaline KMnO_4 or acidic $\text{K}_2\text{Cr}_2\text{O}_7$ or dilute HNO_3 . In these kinds of reaction, the alkyl groups are oxidized to carboxylic acid group, regardless of the size of alkyl group, keeping the benzene ring intact.



Side-chain oxidation of alkylbenzene takes place when there is at least one benzylic hydrogen attached to the carbon. No reaction occurs in the absence of benzylic hydrogen. Thus, these reactions have no effect on tertiary carbons attached to an aromatic ring.

Whatever the length of an alkyl group may be, it gives only one carboxyl group as a product after oxidation. Following example demonstrates the utilization of oxidation reaction in the production of substituted benzoic acid.



Both alkane and benzene are very stable and unsusceptible to oxidation but when put together, the benzylic carbon which is directly attached to the benzene ring becomes more reactive and more susceptible to oxidation.

Oxidation of alkylbenzene containing benzylic protons by KMnO_4 is used as an identification test. Purple colour of KMnO_4 solution is discharged, once consumed in the oxidation reaction. Therefore, one can easily differentiate between benzene, benzene containing primary, secondary, and tertiary alkyl groups by chemical test with KMnO_4 solution.

20.4.3 Addition Reactions of Benzene

We will examine hydrogenation and halogenation addition reactions of benzene in the following reactions.

a) Hydrogenation of benzene

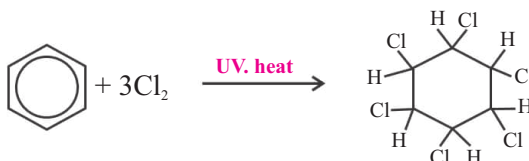
The hydrogenation of benzene and other arenes, involves the addition of 1, 2, or 3 moles of hydrogen to the carbons of benzene. Cyclohexane is produced when benzene is completely hydrogenated. Cyclohexane is a useful solvent and a precursor in the production of other chemicals.



These reactions destroy the electron delocalisation in the original benzene ring, because those electrons are being used to form bonds with the new hydrogen atoms. Although the reactions are exothermic overall because of the strength of all the new carbon-hydrogen bonds, there is a high activation barrier to the reaction. The reactions are done using the same finely divided nickel catalyst that is used in hydrogenation of alkenes and at similar temperatures (around 150°C), but a higher pressure is applied.

b) Addition of Halogens

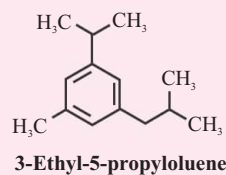
Chlorine and bromine react in the same way. In the absence of a catalyst, UV light and heat are sufficient for complete halogenation. The complete chlorination of benzene is shown below:



Quick Check 20.8



- Predict the product formed when:
 - the compound given here is oxidized using acidified KMnO_4 or $\text{K}_2\text{Cr}_2\text{O}_7$.
 - Bromine is added to chlorobenzene in the presence of AlBr_3 .
 - Nitrobenzene is reduced in the presence of Ni at high temperature and pressure.



Exercise

Q1. Multiple Choice Questions:

I. Which of the following is the major product when methyl chloride (CH_3Cl) reacts with methylbenzene in the presence of AlCl_3 :

- | | |
|-------------------------|-------------------------|
| a) 1,2-dimethyl benzene | b) 1,4-dimethyl benzene |
| c) 1,3-dimethyl benzene | d) both (a) and (b) |

II. Bromine reacts more readily with phenol than with benzene. This is because the:

- benzene ring in phenol is more susceptible to nucleophilic attack
- benzene ring in phenol is deactivated because the oxygen of the OH group is very electronegative



- c) lone pair of electrons on the oxygen atom in phenol overlap with the delocalised electrons in the benzene ring
- d) lone pair of electrons on the oxygen atom enable phenol to act as an electrophile

III. Aluminium chloride catalyses the reaction of benzene and ethanoyl chloride. This is because aluminium chloride.

- a) has significant covalent character
- b) exists as a dimer in non-polar solvents
- c) is an electron pair acceptor
- d) is rapidly hydrolysed

IV. Benzene is nitrated using a mixture of concentrated nitric and sulphuric acids. The sulphuric acid

- a) acts as a solvent for the benzene and the nitric acid
- b) protonates the benzene to speed up the reaction
- c) protonates the nitric acid which acts as a base
- d) reacts with the benzene to form a benzenesulfonic acid intermediate

V. In the reaction of benzene with chloromethane, aluminium chloride is added because it reacts with

- a) benzene to produce an electrophile
- b) benzene to produce a nucleophile
- c) chloromethane to produce a nucleophile
- d) chloromethane to produce an electrophile

VI. Methylbenzene reacts with a mixture of concentrated nitric acid and concentrated sulphuric acid.

What is the name of the mechanism for this reaction?

- a) electrophilic addition
- b) electrophilic substitution
- c) nucleophilic addition
- d) nucleophilic substitution

VII. X-ray diffraction provides evidence that benzene molecules have:

- a) delocalised π -electrons
- b) carbon-carbon bonds that are all the same length
- c) lower thermodynamic stability than molecules of 1,3,5-cyclohexatriene
- d) greater thermodynamic stability than molecules of 1,3,5-cyclohexatriene

VIII. Which statement(s) support(s) the delocalised model for the structure of benzene?

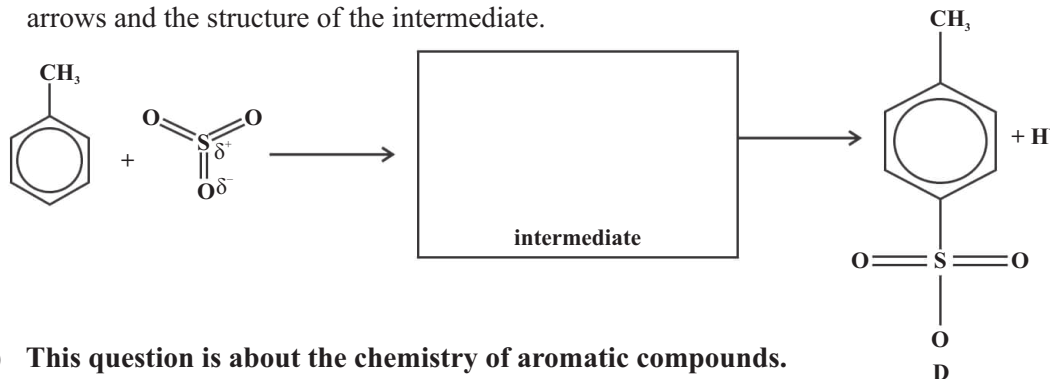
- 1 All carbon-carbon bonds have the same length.
 - 2 The enthalpy change of hydrogenation of benzene is less exothermic than expected.
 - 3 Bromine reacts with benzene less readily than with cyclohexene.
- a) 1, 2 and 3
 - b) Only 1 and 2
 - c) Only 2 and 3
 - d) Only 1



- b) Methylbenzene reacts with sulphur trioxide, SO_3 , to form D, shown below

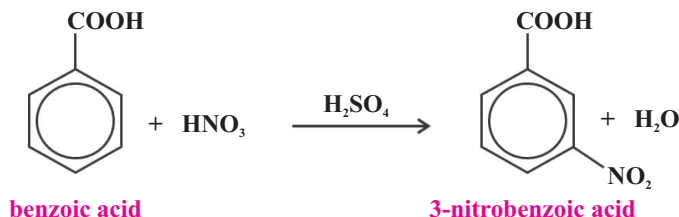
The electrophile in this reaction is SO_3 .

Complete the mechanism for the formation of D. Show curly arrows and the structure of the intermediate.



- c) This question is about the chemistry of aromatic compounds.

Benzoic acid can be nitrated by concentrated nitric acid in the presence of concentrated sulphuric acid as a catalyst, as shown in equation below. The organic product of this reaction is 3-nitrobenzoic acid.



- i) Outline the mechanism for this nitration of benzoic acid. Show how H_2SO_4 behaves as a catalyst.
- ii) A chemist carries out the reaction in Equation above using 4.97 g of benzoic acid.

The chemist obtains 3-nitrobenzoic acid as an impure solid. The chemist purifies the solid to obtain 4.85 g of 3-nitrobenzoic acid.

Describe a method to obtain a pure sample of 3-nitrobenzoic acid from the impure solid, determine the percentage yield and check its purity.

DESCRIPTIVE QUESTIONS

- Q4. In contrast to benzene, the reaction of an alkene with bromine does not need a halogen carrier. Compare the different reactivities of benzene and alkenes towards chlorine.
- Q5. Many organic reactions use electrophiles as reagents. Explain the role of electrophiles in organic chemistry. Your answer should include one reaction of an aliphatic compound and one reaction of an aromatic compound, including relevant mechanisms.



21

HALOGENOALKANES

Student Learning Outcomes

[C-12-D-30 to C-12-D-37]

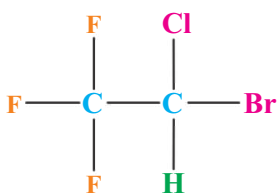
- ⊙ Classify haloalkanes based on the type of halogen atom and its position in the carbon chain, and explain how the molecular structure affects their reactivity.
- ⊙ Explain the organic functional groups involved in a simple haloalkane synthesis and predict the major product(s) based on the reaction conditions.

This includes:

- a. the free-radical substitution of alkanes by Cl or Br in the presence of ultraviolet light, exemplified by the reactions of ethane.
 - b. electrophilic addition of an alkene with a halogen, X_2 , or hydrogen halide, $HX_{(g)}$ at room temperature.
 - c. substitution of alcohol, e.g. by reaction with HX or KBr with H_2SO_4 or H_3PO_4 ; or with PCl_3 and heat; or with PCl_5 ; or with $SOCl_2$.
- ⊙ Describe nucleophilic substitution reactions specifically:
 - a. the reaction with $NaOH_{(aq)}$ and heat to produce an alcohol
 - b. the reaction with KCN in ethanol and heat to produce a nitrile
 - c. the reaction with NH_3 in ethanol heated under pressure to produce an amine
 - d. the reaction with aqueous silver nitrate in ethanol as a method of identifying the halogen present, exemplified by bromoethane
 - ⊙ Describe the elimination reaction with NaOH in ethanol and heat to produce an alkene as exemplified by bromoethane.
 - ⊙ Describe the production of halogenoarenes, i.e., the reaction of benzene with Cl_2 and Br_2 in the presence of a catalyst.
 - ⊙ Compare the reactivity of halogenoalkanes and halogenoarenes using chloroethane and chlorobenzene as examples.
 - ⊙ Predict the major product(s) based on the reaction conditions and the molecular structure of the halogenoalkane.
 - ⊙ Analyze the mechanism and products of a reaction pathway involving a halogenoalkane and use retrosynthesis to deduce the starting materials.

Halogenoalkanes are very useful in daily life, primarily due to their specialized chemical stability. In the past, chlorofluorocarbons (CFCs) were used as **refrigerants** and aerosol propellants, though these are being replaced by eco-friendly alternatives such as Freons. In medicine, halogenated compounds serve as powerful anesthetic agents. Furthermore, they are vital intermediates in manufacturing **polymers**, such as PVC (polyvinyl chloride) for piping and PTFE (Teflon) for non-stick cookware.

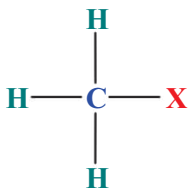




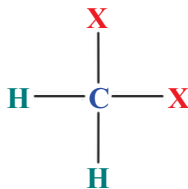
Halothane is a halogenated hydrocarbon widely used as a powerful inhalation anesthetic. It induces a reversible loss of consciousness during surgeries. Previously, chloroform and other chlorinated anesthetics were used, which are banned now due to their toxicity and safety concerns.



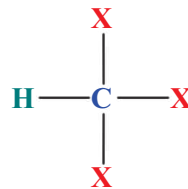
A halogenoalkane is formed when one or more hydrogen atoms of an alkane are replaced by halogen atoms. They may be mono, di, tri or poly halogenoalkanes depending upon the number of halogen atoms (-x) present in the molecule.



Monohalogenoalkane



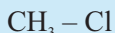
Dihalogenoalkane



Trihalogenoalkane

Among these, monohalogenoalkanes are also called alkyl halides. Their general formula is $\text{R}-\text{X}$, where R may be methyl, ethyl, propyl, etc., and X represents halogen atoms (F, Cl, Br, I). Monohalogenoalkane or alkyl halides are further classified into primary, secondary and tertiary monohalogenoalkanes depending upon the type of carbon atom bearing the halogen atom.

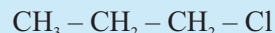
In a primary halogenoalkane, the halogen atom is attached with a carbon which is further attached to one or no carbon atom e.g.



chloromethane

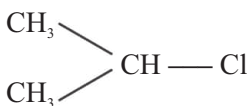


chloroethane



1-chloropropane

Secondary halogenoalkanes are those in which the halogen atom is attached with a carbon atom which is further attached to two other carbon atoms directly.

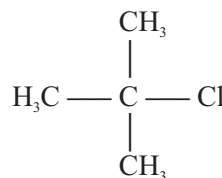


2-chloropropane



2-chlorobutane

In a **tertiary halogenoalkane**, the halogen atom is attached to a carbon atom which is further attached to three carbon atoms directly.



2-chloro-2-methylpropane



Quick Check 21.1

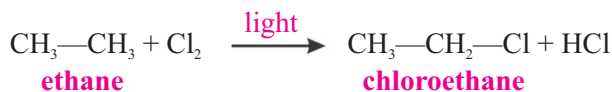


- Write down the IUPAC name of the compound, $(\text{CH}_3)_2\text{CH}-\text{CH}_2-\text{Cl}$
- Draw all possible structures of a compound having the molecular formula $\text{C}_5\text{H}_{11}\text{Cl}$. Classify each as primary, secondary or tertiary chloride.



21.1 PREPARATION OF HALOGENOALKANES

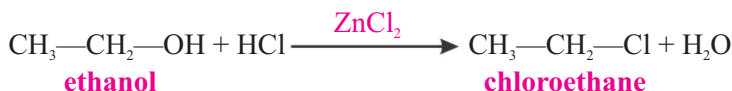
i Halogenoalkanes can be prepared by the halogenation of alkanes in the presence of light.



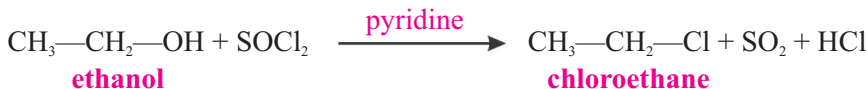
ii They can also be prepared by the electrophilic addition of hydrogen halides to alkenes.



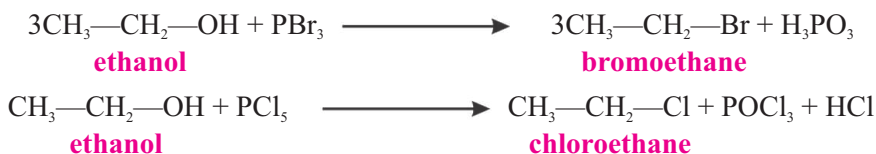
iii Alcohols may be converted to the corresponding alkyl halides by the action of halogen acid in the presence of ZnCl_2 , which acts as a catalyst.



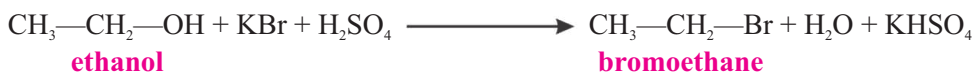
iv Alcohols also react with thionyl chloride in pyridine as a catalyst to give alkyl chlorides. This method is especially useful since the by-products (HCl and SO_2) are gases which go off leaving behind the pure product.



v Phosphorus trihalides or phosphorus pentahalides react with alcohols to replace $-\text{OH}$ group by a halo group.



vi Alcohols can be converted to halogenoalkanes by reacting with potassium bromide and an acid like sulphuric acid (H_2SO_4) or phosphoric acid (H_3PO_4). This method is commonly used to prepare bromoalkanes and iodoalkanes. The acid first reacts with potassium bromide to give hydrogen bromide which then further reacts with alcohols to give bromoalkanes.



Phosphoric acid is preferably used to prepare iodoalkanes because it is a weak oxidizing agent and less likely to oxidize iodide ions to iodine.



MORE INFO

Interesting Information

Bromoethane is naturally emitted primarily by **marine algae and phytoplankton such as trichodesmium**. These organisms convert seawater bromide into volatile organobromides. Once in the atmosphere, bromoethane contributes to the global bromine cycle and plays a role in stratospheric ozone depletion.



Quick Check 21.2

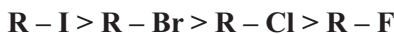


- Give two methods to convert methanol into chloromethane.
- Give reactions of propanol with SOCl_2 and PBr_3 .
- Can we prepare fluoromethane using methane and fluorine gas?

21.2 REACTIVITY OF HALOGENOALKANES

A halogenoalkane molecule ($\text{R} - \text{X}$) consists of two parts, an alkyl group with a partial positive charge on the carbon atom attached to halogen atom and the halide atom with a partial negative charge. Experiments have shown that the strength of carbon halogen bond is the main factor which decides the reactivity of haloalkanes. The weaker bond will be more easily broken and make the molecule more reactive. **Table 21.1** shows the bond energies of $\text{C} - \text{X}$ bonds in alkyl halides.

The strength of the bonds shows that iodo compounds (with the weakest bonds) would be the most reactive halogenoalkanes, while fluoro compounds will be the least reactive i.e., the order of reactivity of halogenoalkanes should be:



In fact, the $\text{C} - \text{F}$ bond is so strong that fluoroalkanes do not react under ordinary conditions. Some other factors which may affect the reactivity of halogenoalkanes are, bond polarity, steric hindrance, inductive effect, etc.

Table 21.1 Bond energies of different $\text{C} - \text{X}$ bonds

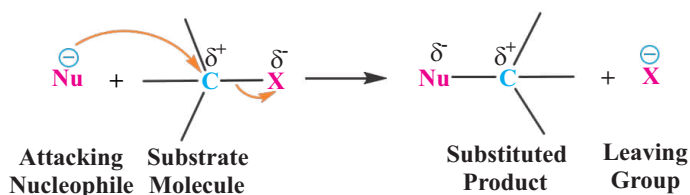
Bond	Bond Energy (kJ/mol)
$\text{C} - \text{F}$	467
$\text{C} - \text{Cl}$	346
$\text{C} - \text{Br}$	290
$\text{C} - \text{I}$	228

21.3 REACTIONS OF HALOGENOALKANES

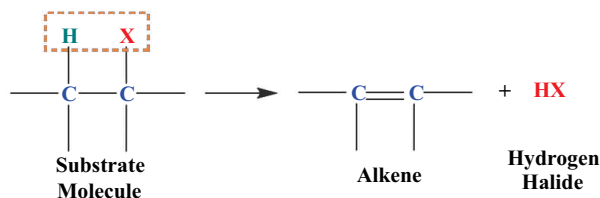
The $\text{C} - \text{X}$ bond in halogenoalkanes is polar due to the difference of electronegativity between C and the halogen atom. The carbon of $\text{C} - \text{X}$ acts as an electrophilic centre, which can be attacked by a nucleophile. Alternatively, the hydrogen attached to the carbon atom may be attacked by a base. These two possibilities result in two types of reaction of halogenoalkanes

- Those reactions in which the halogen is replaced by some other atom or a group (nucleophilic substitution, or S_N reactions).





- b) Those that involve the removal of HX from haloalkanes (elimination, or E reactions), results in the formation of alkenes.



21.3.1 Nucleophilic Substitution Reactions

Alkyl halides may undergo nucleophilic substitution reactions in two different ways:

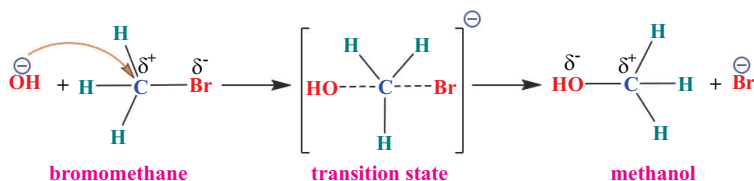
- Nucleophilic Substitution Bimolecular (S_N2)
- Nucleophilic Substitution Unimolecular (S_N1)

Nucleophilic substitution reactions on alkyl halides involve two main processes, the departure of leaving group (breaking of C–X bond) and the attack of nucleophile (the formation of C–Nu bond). If the two processes occur simultaneously in single step the mechanism is called S_N2 . But if the two changes occur in two separate steps, i.e., the bond breaks in first step followed by the formation of a new bond in second step, then the mechanism is called S_N1 .

i) Nucleophilic Substitution Bimolecular (S_N2)

This is a single step mechanism. As soon as the nucleophile starts attacking the electrophilic carbon of the substrate, the bond with which the leaving group is attached, starts breaking. In other words, the extent of bond formation is equal to the extent of bond breaking.

Another important feature of this mechanism is the direction of the attack of the attacking nucleophile. It attacks from the side which is opposite to the leaving group. The attack of the nucleophile and the departure of the leaving group, everything occurs at the same time.



Since in this mechanism, the reaction takes place in only one step, which is also a rate-determining step and two molecules are participating in this step, it is a bimolecular reaction.

Kinetic studies of the reactions involving S_N2 mechanism have shown that the rates of such reactions depend upon both the concentrations of alkyl halide and the attacking nucleophile. Mathematically, the rate can be expressed as:



$$\text{Rate} = k [\text{Alkyl halide}]^1 [\text{Nucleophile}]^1$$

$$\text{order} = 1 + 1 = 2$$

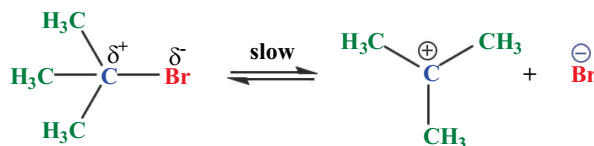
A typical S_N2 reaction is a second order reaction.

Among the monohalogenoalkanes, primary monohalogenoalkanes always follow S_N2 mechanism whenever they are attacked by nucleophiles. This is due to steric reasons, as in primary monohalogenoalkanes the substrate carbon is attached with hydrogen atoms or only one carbon atom, the nucleophile can approach and attack the electrophilic carbon easily.

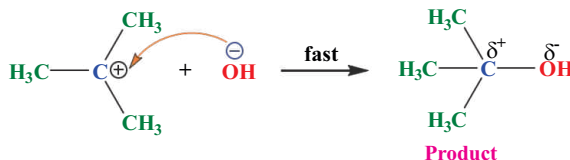
ii) Nucleophilic Substitution Unimolecular (S_N1)

This type of mechanism involves two steps. The first step is the reversible ionization of the alkyl halide in the presence of aqueous acetone or aqueous ethyl alcohol. This step provides a carbocation as an intermediate. In the second step, this carbocation is attacked by the nucleophile to give the product.

First Step:



Second Step:

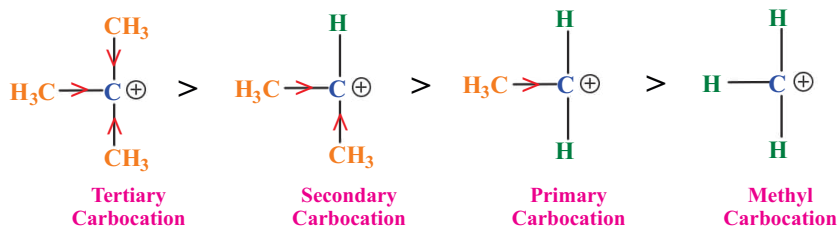


Since the first step involves the breaking of a covalent bond so it is a slow step as compared to the second step, which involves the energetically favourable combination of ions. The first step is, therefore, called the rate-determining step. The mechanism is called unimolecular because only one molecule takes part in the rate-determining step.

Reactions involving S_N1 mechanism show first order kinetics and the rates of such reactions depend only upon the concentration of the alkyl halide. The rate equation of such reactions can be written as follows:

$$\text{Rate} = k [\text{Alkyl halide}]$$

Tertiary monohalogenoalkanes always follow S_N1 mechanism whenever they are attacked by a nucleophile, the major reason is the formation of the stable tertiary carbocation. Moreover three bulky groups attached with the electrophilic carbon prevent the attacking nucleophile to attack from the backside of leaving group. The substrate molecule thus prefers to follow the S_N1 mechanism.



Decreasing stability order of carbocations due to decrease in positive inductive effect (+I).



The mechanism shows that a carbocation is formed in the rate-determining step, so, the more stable the carbocation, the more easily it is formed. Tertiary carbocations are more stable than secondary carbocations which are in turn, more stable than the primary carbocations.

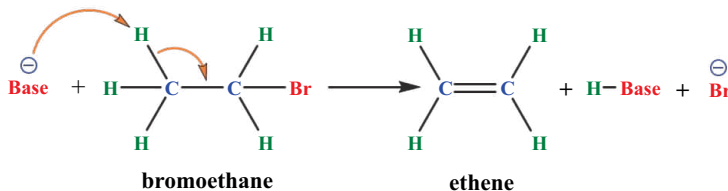
A secondary halogenoalkane can undergo both S_N2 and S_N1 reaction mechanism, depending upon the nature of solvent.

21.3.2 β -Elimination Reactions

β -elimination is a reaction in which a hydrogen atom attached to the β -carbon of the alkyl halide and the halogen atom on the adjacent carbon atom are removed from a halogenoalkane. This reaction occurs when a base attacks the β -hydrogen atom of the halogenoalkane. The removal of the halogen takes place either simultaneously or after the removal of the hydrogen atom. Thus, an alkene molecule is obtained instead of a substitution product. These reactions take place simultaneously with substitution reactions and often compete with them. Like nucleophilic substitution, the elimination reactions can follow two types of mechanism; E2 or E1.

Elimination Bimolecular (E2)

In E2 mechanism, the base attacks the β hydrogen atom and the leaving group leaves at the same time with the formation of a carbon-carbon double bond. The single step E2 elimination mechanism is given below.



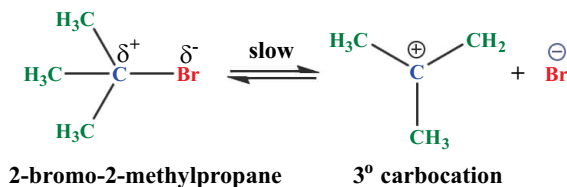
E2 reaction is bimolecular and the rate of this reaction depends upon the concentrations of the alkyl halide and the base. Like S_N2 reactions, the molecularity of E2 reactions is also two and these reactions show second order kinetics.

$$\text{Rate} = k [\text{Alkyl halide}]^1 [\text{Base}]^1 \quad \text{Order} = 1 + 1 = 2$$

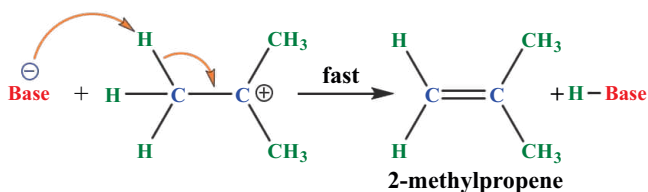
Elimination Unimolecular (E1)

In E1 mechanism, like S_N1 mechanism, the first step is the slow ionization of the substrate to give a carbocation. In the second step, the base attacks the β -hydrogen atom to give an alkene as a product.

Step - 1



Step - 2



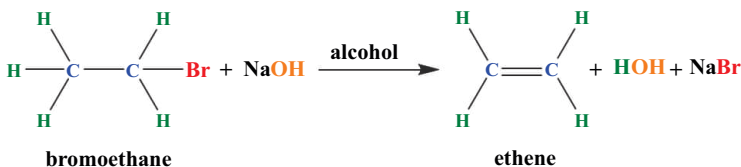
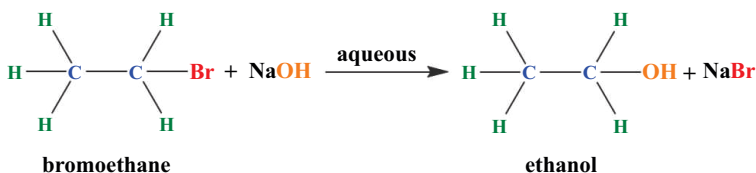
E1 mechanism is a unimolecular mechanism and the rate of the reaction depends only upon the concentration of the alkyl halide molecule. Primary halogenoalkanes generally follow E2 mechanism whereas tertiary halogenoalkanes follow E1 mechanism. However, secondary halogenoalkanes can show both E2 and E1 reactions according to the choice of the solvent.

21.4 EXAMPLES OF REACTIONS OF HALOGENOALKANES

I. With Sodium Hydroxide

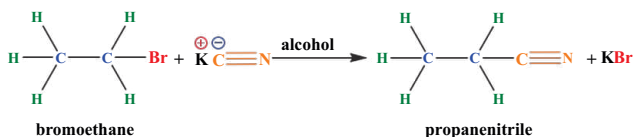
A halogenoalkane reacts with aqueous sodium hydroxide to give both substitution and elimination products depending upon the reaction conditions. Hydroxide ion is both a good nucleophile and a good base. So, when it attacks as a nucleophile, it replaces the halogen atom of the halogenoalkane to form a substitution product, alcohol. As a base, it removes both the β -hydrogen atom and the halogen atom to give an elimination product, an alkene. The reaction takes place at higher temperature under reflux conditions to avoid the loss of volatile products. Bromoethane reacts with aqueous sodium hydroxide to give ethanol as well as ethene.

Substitution Reaction



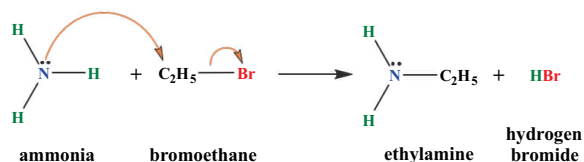
ii. Reactions of Halogenoalkanes with KCN

Since cyanide ion (CN^-) is a strong nucleophile but a weak base so it reacts with halogenoalkanes to give substitution product, a nitrile. The reaction is typically carried out by heating the halogenoalkane with an ethanolic solution of potassium cyanide under reflux. Bromoethane reacts with potassium cyanide to give propanenitrile.

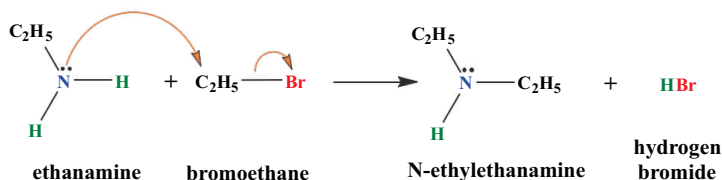


iii. Reactions of Halogenoalkanes with Ammonia

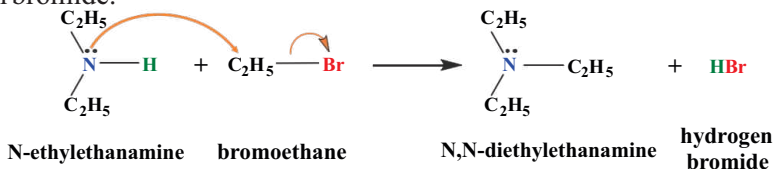
Ammonia is a good nucleophile and it reacts with halogenoalkanes favourably. Different types of amines can be produced if the amounts of halogenoalkane and ammonia are carefully controlled.



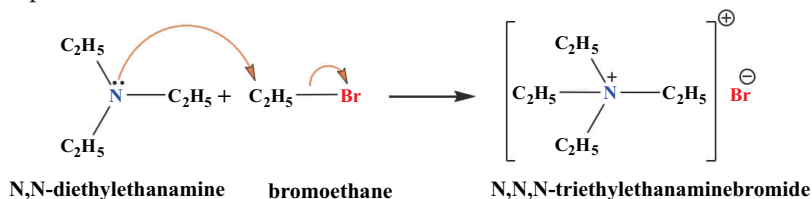
Since ethanamine is also a nucleophile, it can compete with ammonia to react with alkyl halide to give diethyl amine.



N-ethylethanamine will act as a nucleophile and will attack on another bromoethane molecule to form hydrogen bromide.



If a large excess of bromoethane is used, the reaction may proceed to give quaternary ammonium salt as the final product.



iv. Reactions of Halogenoalkanes with Aqueous Silver Nitrate

This reaction is carried out in a mixture of water and ethanol, the alcohol in this mixture helps to dissolve the halogenoalkane. Water reacts with halogenoalkane as a nucleophile replacing the halide ion.



The released halide ion then reacts with silver nitrate to give a precipitate with a characteristic colour corresponding to the halide ion present. Thus, the reaction helps to detect the halide ion present in halogenoalkanes.



Comparing the rates of formation of silver halides in this reaction gives us a clue about the different reactivities of halides. The quicker the precipitate appears, the more reactive is the halogenoalkane. An iodoalkane produces a precipitate very quicker than bromoalkane. A chloroalkane, however, reacts very slowly.

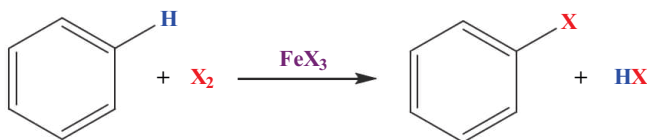



Quick Check 21.3


- Why halogenoalkanes are considered as very reactive class of organic compounds?
- Complete the following equation. $C_2H_5Br + CH_3COONa \longrightarrow$
- How will you convert ethane into ethanol and ethene?
- Give the reaction of bromopropane with KCN. Is this a substitution reaction or an elimination reaction? Name the main product of this reaction.

21.5 HALOGENOARENES

Halogenoarenes like chlorobenzene and bromobenzene are prepared by reacting benzene with either chlorine or bromine in the presence of a catalyst, anhydrous $FeCl_3$ or $FeBr_3$. The reaction is called electrophilic aromatic substitution reaction and is typically carried out at room temperature.

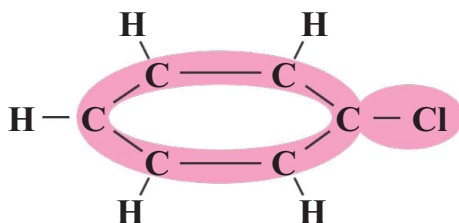


21.5.1 Comparison of Reactivities of Halogenoalkanes and Halogenoarenes

Halogenoalkanes are aliphatic organic compounds in which halogen atom is attached with an alkyl group. Owing to the difference in the electronegativity values of carbon and halogen a partial positive charge is developed on the carbon atom attached to the halogen making it an electrophile. This electrophilic carbon atom invites nucleophiles to attack on it giving a vast body of reactions called nucleophilic substitution reactions.

The attack by bases on the hydrogen atom attached with the carbon atom adjacent to it gives another important class of reactions called elimination reactions. These reactions have been discussed in detail previously.

However, in halogenoarenes, the electron pair on the chlorine atom is delocalised due to the involvement of the chlorine lone pair with the aromatic ring as shown below. The carbon-halogen bond is stronger due to the partial double-bond character, resulting from this delocalisation. The strength of $C-Cl$ bond, thus increases making it difficult to break. Consequently, the halogenoarenes, are less reactive and synthetically less useful.



**Quick Check 21.4**

- What is the role of iron halide in the preparation of halogenoarene?
- Chlorobenzene does not react with NaOH under normal conditions, but chloroethane does; explain why?
- Can chlorobenzene undergo elimination? Explain why or why not?

**Interesting Information**

Some halogen compounds like DDT have been used as pesticides, but their persistence in the environment has led to restrictions or banning of their use in developed countries. Because DDT is a cheap and effective mosquito control agent, some developing countries have experienced a sharp increase in malaria deaths following its removal from stores. It is therefore, advised to restrict its use for environmental protection.

Exercise**Q1. MULTIPLE CHOICE QUESTIONS:****I Encircle The Correct Answer.****I) Which of the following compound is a primary halogenoalkane?**

- | | |
|---------------------------------|-----------------------------|
| a) 1-bromo-2,2-dimethyl propane | b) 2-bromo-3-methyl butane |
| c) 2-bromopropane | d) 2-bromo-2-methyl propane |

II) The reactivity order of halogenoalkanes for a particular alkyl group is:

- Fluoride > Chloride > Bromide > Iodide
- Chloride > Bromide > Fluoride > Chloride
- Iodide > Bromide > Chloride > Fluoride
- Bromide > Iodide > Chloride > Fluoride

III) S_N2 reactions can be best carried out with:

- | | |
|-----------------------------|------------------------------|
| a) Primary halogenoalkanes | b) Secondary halogenoalkanes |
| c) Tertiary halogenoalkanes | d) Halogenoarenes |

IV) Elimination bimolecular reactions involve:

- | | |
|-------------------------|--------------------------|
| a) First order kinetics | b) Second order kinetics |
| c) Third order kinetics | d) Zero order kinetics |

V) For which mechanisms, the first step involved is the same:

- | | |
|----------------------------|----------------------------|
| a) E1 and E2 | b) E2 and S _N 2 |
| c) S _N 1 and E2 | d) E1 and S _N 1 |



VI) Halogenoalkanes are considered to be very reactive compounds towards nucleophiles, because:

- a) They have an electrophilic carbon
- b) They have an electrophilic carbon and a good leaving group
- c) They have an electrophilic carbon and a bad leaving group
- d) They have a nucleophilic carbon and a good leaving group

VII) 2-chloropropane will follow which mechanism when it reacts with aqueous KOH resulting in the formation of an alcohol.

- a) S_N1
- b) S_N2
- c) Mixed S_N1 and S_N2
- d) E1

VIII) Which one of the following is not a nucleophile?

- a) H_2O
- b) H_2S
- c) BF_3
- d) NH_3

IX) When aqueous solution of alkyl halides are reacted with $AgNO_3$, the most rapid ppt. formation occurs with:

- a) fluoroalkane
- b) chloroalkane
- c) bromoalkane
- d) iodoalkane

X) The rate of E1 reaction depends upon:

- a) The concentration of the substrate
- b) The concentration of the base
- c) The concentrations of substrate as well as base
- d) Neither the concentration of substrate nor the base

Q2. SHORT ANSWER QUESTIONS

- a) Why halogenoalkanes are known to be very reactive compounds?
- b) Why fluoroalkanes rarely undergo nucleophilic substitution reactions?
- c) Why primary halogenoalkanes undergo substitution reactions by S_N2 mechanism?
- d) Does 1-bromo-2,2-dimethylpropane undergo elimination reaction or not? Justify.
- e) Why tertiary halogenoalkanes undergo elimination reaction by E1 mechanism?
- f) Hydroxide ion is a good base as well as a good nucleophile. Justify.
- g) What is the role of iron chloride ($FeCl_3$) during the chlorination of benzene?
- h) Which among haloalkanes or haloarenes, is more reactive towards nucleophiles?
- i) Write the equation for the reaction of 1-chloropropane with $AgNO_3$.



Q3. CONSTRUCTED RESPONSE QUESTIONS

- Predict the mechanism which the chloroalkane will adopt while giving nucleophilic substitution reactions.
- Why nucleophilic substitution and elimination reactions of haloalkanes proceed together under similar conditions?
- It is difficult for chlorobenzene to undergo nucleophilic substitution reactions but it is easier for it to undergo electrophilic substitution reactions. Give reasons.
- Differentiate between E2 and E1 reactions. Draw a table for your response.
- Why does $\text{CH}_3\text{-CH}_2\text{-I}$ give a precipitate with aqueous silver nitrate earlier than $\text{CH}_3\text{-CH}_2\text{-Cl}$?

DESCRIPTIVE QUESTIONS

- Q4.** Describe how substitution of alcohol with following reagents help to synthesize halogenoalkanes
- | | |
|--|-------------------------------------|
| i) KBr with H_2SO_4 | ii) $\text{SOCl}_2/\text{Pyridine}$ |
| iii) PCl_3 | iv) PCl_5 |
- Q5.** Describe nucleophilic substitution reactions of halogenoalkane starting from bromoethane with following reagents:
- | | |
|------------------------------|----------------------------|
| i) Aqueous NaOH | ii) Ethanolic KCN |
| iii) Ethanolic NH_3 | |
- Q6.** Compare the reactivity of halogenoalkanes and halogenoarenes using chloroethane and chlorobenzene as examples.
- Q7.** Describe the $\text{S}_{\text{N}}1$ and $\text{S}_{\text{N}}2$ mechanisms of nucleophilic substitution in halogenoalkanes.



22

HYDROXY
COMPOUNDS

Student Learning Outcomes

[C-12-D-41 to C-12-D-58]

- ⊙ State the reactions (reagents and conditions) by which alcohols can be produced:
 - a. electrophilic addition of steam to an alkene, $\text{H}_2\text{O}_{(g)}$ and H_3PO_4 catalyst.
 - b. reaction of alkenes with cold dilute acidified potassium manganate (VII) to form a diol.
 - c. substitution of a halogenoalkane using $\text{NaOH}_{(aq)}$ and heat.
 - d. reduction of an aldehyde or ketone using NaBH_4 or LiAlH_4 .
 - e. reduction of carboxylic acid using LiAlH_4 .
 - f. hydrolysis of an ester using dilute acid or dilute alkali and heat, describe the reaction with oxygen (combustion) of organic hydroxy compounds.
- ⊙ Describe substitution to halogenoalkanes, e.g. by reaction with HX or KBr with H_2SO_4 or H_3PO_4 ; or with SOCl_2 .
- ⊙ Describe the reaction of hydroxy organic compounds with $\text{Na}_{(s)}$.
- ⊙ Describe the oxidation with acidified $\text{K}_2\text{Cr}_2\text{O}_7$ or acidified KMnO_4 to: carbonyl compounds by distillation, carboxylic acids by refluxing (primary alcohols give aldehydes which can be further oxidized to carboxylic acids, secondary alcohols give ketones, tertiary alcohols cannot be oxidized).
- ⊙ Describe the dehydration of alcohols to alkenes by using a heated catalyst, e.g., Al_2O_3 or a concentrated acid.
- ⊙ Describe the formation of esters by reaction with carboxylic acids and concentrated H_2SO_4 or H_3PO_4 as catalyst as exemplified by ethanol.
- ⊙ Classify alcohols as primary, secondary and tertiary alcohols, to include examples with more than one alcohol group.
- ⊙ State characteristic distinguishing reactions, e.g., mild oxidation with acidified $\text{K}_2\text{Cr}_2\text{O}_7$, color change from orange to green.
- ⊙ Deduce the presence of a $\text{CH}_3\text{CH}(\text{OH}) -$ group in an alcohol, $\text{CH}_3\text{CH}(\text{OH}) - \text{R}$, from its reaction with $\text{I}_2_{(aq)}$ to form a yellow precipitate of tri-iodomethane and an ion, RCO_2^- .
- ⊙ Explain the acidity of alcohols compared with water.
- ⊙ Describe the reaction with acyl chlorides to form esters using ethyl ethanoate.
- ⊙ Recall the reactions (reagents and conditions) by which phenol can be produced: Reaction of phenylamine with HNO_2 or NaNO_2 and dilute acid below 1°C to produce the diazonium salt; further warming of the diazonium salt with H_2O to give phenol.
- ⊙ Recall the chemistry of phenol, as exemplified by the following reactions: with bases, for example $\text{NaOH}_{(aq)}$ to produce sodium phenoxide with $\text{Na}_{(s)}$ to produce sodium phenoxide and $\text{H}_2_{(g)}$ in $\text{NaOH}_{(aq)}$ with diazonium salts, to give azo compounds nitration of the aromatic ring with dilute $\text{HNO}_3_{(aq)}$ at room temperature to give a mixture of 2-nitrophenol and 4-nitrophenol bromination of the aromatic ring with $\text{Br}_{2(aq)}$ to form 2,4,6-tribromophenol.



- ⦿ Explain, the acidity of phenol.
- ⦿ Describe the relative acidities of water, phenol and ethanol.
- ⦿ Explain, why the reagents and conditions for the nitration and bromination of phenol are different from those for benzene.
- ⦿ Recall that the hydroxyl group of phenol directs to the 2-, 4- and 6- positions.
- ⦿ Apply knowledge of the reactions of phenol to those of other phenolic compounds, e.g. naphthol.

Alcohols and phenols are hydroxy organic compounds with at least one hydroxyl group attached to an aliphatic or an aryl carbon, respectively. The study of alcohols and phenols holds a significant place due to their widespread occurrence and diverse applications. Almost everyone is aware of ethanol, also known as ethyl alcohol or grain alcohol. It is commonly known that alcohols can be used as fuels.



Left: Alcohol is produced from bio-based materials and is used as a biofuel.

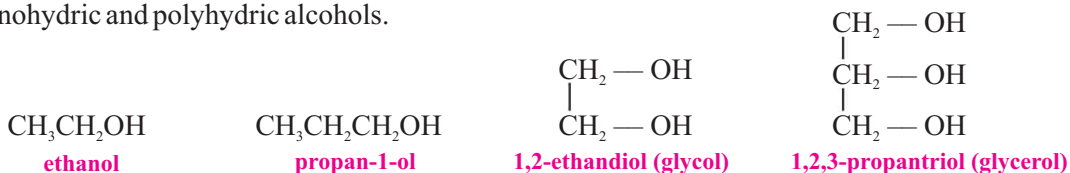
Right: Phenol is an ingredient in disinfectants, such as soaps, hospitals disinfectant liquids, etc.

After Louis Pasteur's research revealed the existence of bacteria, scientists started cleaning surgical instruments and wounds with phenol solutions in 1867. A patient's chances of surviving surgery significantly increased due to the phenol solution's potent antiseptic properties. Since phenol burns healthy tissues, it was too potent for this use, and alternatives were eventually discovered.

22.1 ALCOHOLS

Hydroxyl group (-OH) is the functional group of all alcohols. Alcohols are represented by the general formula ROH, where R is an alkyl or aryl group. The family also includes familiar substances as cholesterol and the carbohydrates. Methanol (CH₃OH) and ethanol (CH₃CH₂OH) are the first two members of the homologous series of monohydric alcohols.

Depending on the number of hydroxyl groups attached, alcohols can be classified into monohydric and polyhydric alcohols.

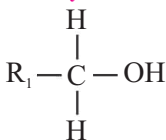


Depending on the number of carbon atoms which are directly attached to the carbon that is bonded with the -OH group, alcohols can be classified into three types.

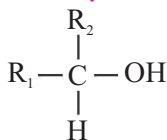
- 🍷 **A primary (1°) alcohol** is one in which the OH group is attached a primary carbon atom. Its general formula is R₁CH₂OH.
- 🍷 **A secondary (2°) alcohol** is one in which the OH group is attached to a secondary carbon atom. Its general formula is R₂CHOH.

 A **tertiary (3°) alcohol** is one in which the OH group is attached a tertiary carbon atom. Its general formula is R_3COH .

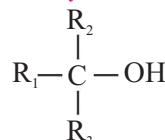
Primary alcohol



Secondary alcohol



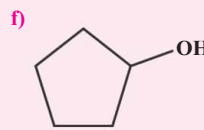
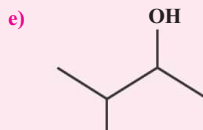
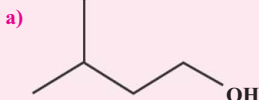
Tertiary alcohol



Quick Check 22.1



I. Which ones of these are 1°, 2° and 3° alcohols?



22.2 ACIDITY OF ALCOHOLS AND PHENOLS

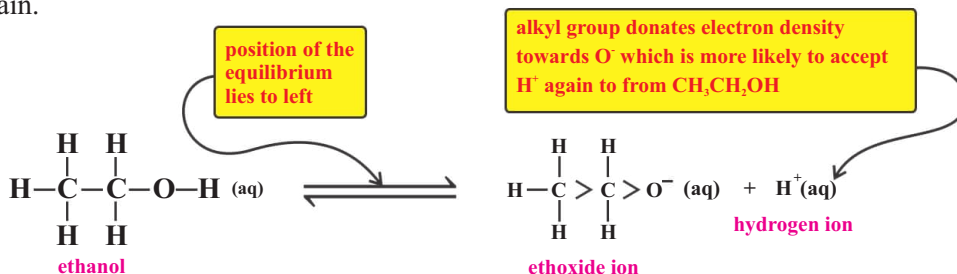
Alcohols have a low degree of dissociation. This means that when dissolved in water, alcohol molecules do not dissociate (split up) to a great extent. The position of the equilibrium lies to the left, meaning that there are far more alcohol molecules than $RO^-_{(aq)}$ and $H^+_{(aq)}$ ions.



When water dissociates, the position of the equilibrium still lies to the left, but there are more H^+ ions compared to the dissociation of alcohols. As alcohols have a lower $[H^+_{(aq)}]$ in solution compared to water, alcohols are weaker acids than water.

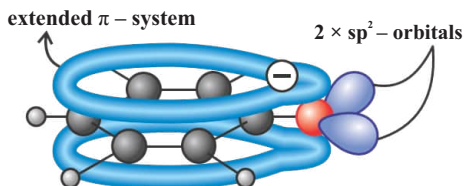
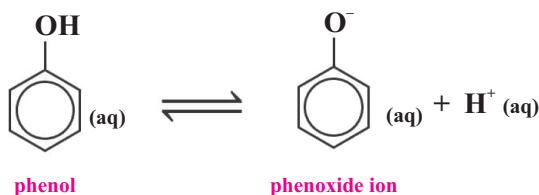


The reason for alcohols being less acidic than water is the presence of alkyl groups. Alkyl groups are electron donating groups. Electron-donating species push electrons into a covalent bond and are said to have a positive inductive effect. The alkyl groups destabilize the alkoxide ion, which is formed by removing one proton (H^+) from the alcohol molecule. The oxygen atom in the alkoxide ion is bonded to an electron-donating alkyl group. This means that there is more electron density on the O atom. The alkoxide ion is, therefore, more likely to accept an H^+ ion and form the alcohol again.



Although phenol compounds contain an alcohol (-OH) group, they are weakly acidic and this is due to the delocalisation of one of the lone pairs from the oxygen atom into the aromatic ring. The delocalisation stabilises the phenoxide ion, the conjugate base of phenol.

This is possible as one of the lone pairs on the oxygen atom overlaps with the delocalised π system of the ring. Because of this delocalisation, there is less charge density on the oxygen atom. The H^+ ions are, therefore, not strongly attracted to the phenoxide ion and are less likely to reform the phenol molecule. This means that phenol is more likely to lose a proton (and act as an acid) rather than to gain a proton (and act as a base).



The negative charge on the oxygen is delocalised and spread on the aromatic ring making it a stable ion

The relative acidities are as follows: **phenol > water > ethanol**



Quick Check 22.2

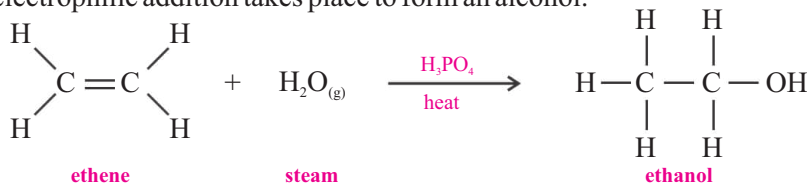


- Compare the relative acidic strength of methanol and ethanol.
- Showing the electron delocalisation explain why the phenoxide (PhO^-) is more stable than the ethoxide ion ($\text{C}_2\text{H}_5\text{O}^-$).
- Alkali metals react with stronger acids to produce the hydrogen gas. A piece of sodium is added to two beakers; one containing ethanol and the other phenol.
 - Predict in which beaker the hydrogen gas will be evolved earlier and more rapidly.
 - If the phenolphthalein indicator is already present before adding sodium to the above solutions, which solution will turn pink earlier?

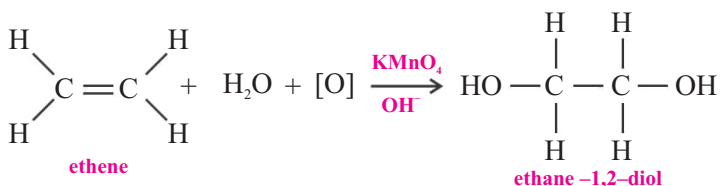
22.3 SYNTHESIS OF ALCOHOLS

Alcohols can be prepared from alkenes, halogenoalkanes, carbonyl compounds, carboxylic acids, and esters.

D) When hot steam is reacted with an alkene, using concentrated phosphoric acid (H_3PO_4) as a catalyst, electrophilic addition takes place to form an alcohol.

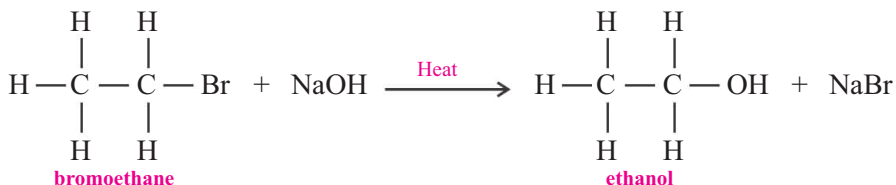


ii. Alcohols are obtained by the oxidation of alkenes with cold, dilute KMnO_4 , a mild oxidising agent.

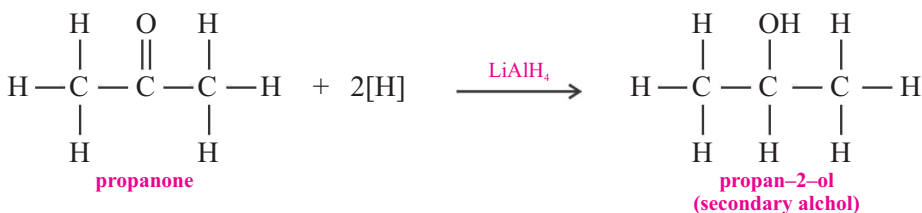
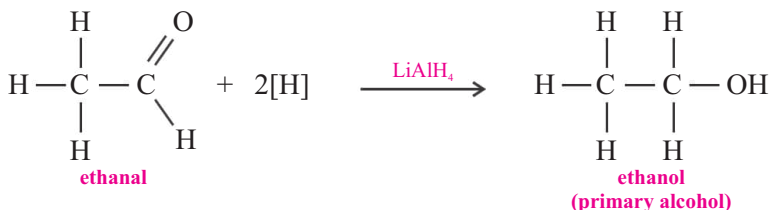


Oxidation of alkenes using cold, dilute KMnO_4 to form a diol

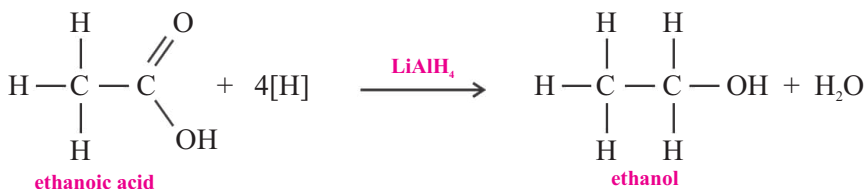
- iii) The halogen atom in halogenoalkanes can be substituted by $-OH$ group when heated with aqueous $NaOH$ in a nucleophilic substitution reaction, giving an alcohol.



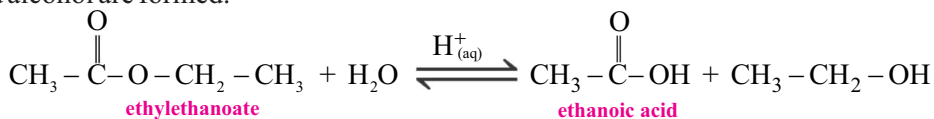
- iv) Aldehydes and ketones can be reduced by reducing agents such as $NaBH_4$ or $LiAlH_4$ to obtain alcohols. Aldehydes are reduced to primary alcohols. Ketones are reduced to secondary alcohols.



- v) Similarly, carboxylic acids are reduced by $LiAlH_4$ to primary alcohols.



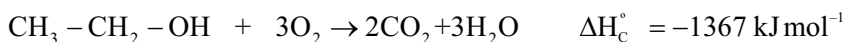
- vi) When an ester is heated with dilute acid or alkali, hydrolysis takes place and a carboxylic acid and alcohol are formed.



22.4 REACTIONS OF ALCOHOLS

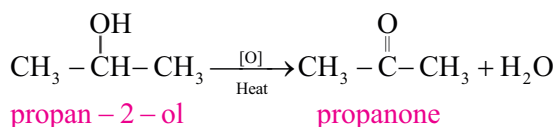
I. Combustion of alcohols

Alcohols when ignited, undergo complete combustion to form carbon dioxide and water.



- D) The above reaction is highly exothermic; this is why the alcohol is used as an alternate to petrol in some countries.





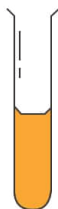
Therefore, only the oxidation of primary and secondary alcohols will change the colour of acidified $\text{K}_2\text{Cr}_2\text{O}_7$ solution as the **orange** $\text{Cr}_2\text{O}_7^{2-}$ ions are reduced to **green** Cr^{3+} ions, which is used to check the presence of primary or secondary alcohol.



propan-1-ol
(primary alcohol)



propan-2-ol
(secondary alcohol)



2-methyl-propan-2-ol
(tertiary alcohol)

Only propan-1-ol and propan-2-ol, which are primary and secondary alcohols respectively, can get oxidised, turning the orange solution green; no colour change is observed with 2-methyl-propan-2-ol, which is a tertiary alcohol.

MORE INFO

Interesting Information

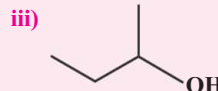
Driving after consuming alcohol is very dangerous. A breathalyser is a device that is used by the traffic officers to check if a driver is drunk or not. This device uses the oxidation of ethanol, which requires electrons. The amount of current used is proportional to the amount of alcohol consumed.



Quick Check 22.4



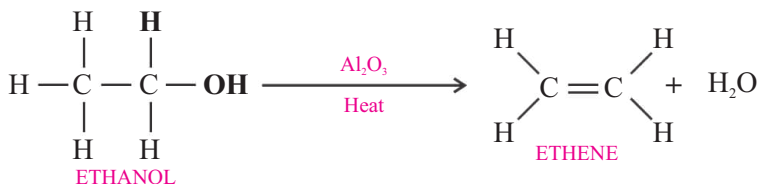
- a) Three alcohols A, B and C are structural isomers of $\text{C}_4\text{H}_{10}\text{O}$. Each alcohol is refluxed with acidified dichromate(VI), $\text{H}^+/\text{Cr}_2\text{O}_7^{2-}$.



- Write the systematic name for alcohol C.
 - Write the equation for the complete combustion of alcohol A.
- b) Acidified potassium manganate(VII), KMnO_4 , is a purple oxidising agent. What colour change would you observe when alcohols are oxidised with manganate ions (MnO_4^-).
- c) Draw the structures for the organic products of the oxidation of the following. If there is no reaction, write 'NONE'.

v. Dehydration of alcohols

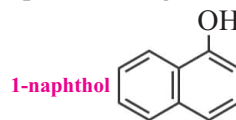
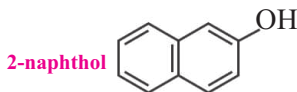
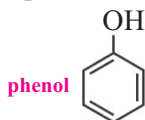
Alcohols can also undergo dehydration to form alkenes. Dehydration is the type of the elimination reaction in which a water molecule is removed.



Dehydrating agents may be aluminium oxide, conc. sulphuric acid, conc phosphoric acid, etc.

22.5 PHENOLS

Compounds in which a hydroxyl group is bonded to an arene called phenols. The chemical formula of the simplest phenol is C_6H_5OH . Phenol is also known as carbolic acid and was used as carbolic soap. Phenol is a crystalline white solid. Some examples of phenols are given below:

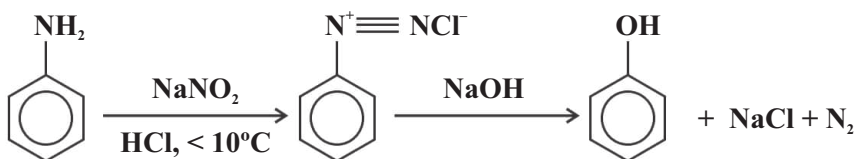


Phenols can be produced by the reaction of phenylamine with nitrous acid (HNO_2). The nitrous acid used here is produced *in situ*. The reaction occurs in three steps.

Step 1 - The HNO_2 is so unstable that it needs to be prepared in a test-tube by reacting sodium nitrite ($NaNO_2$) and dilute hydrochloric acid (HCl) while keeping the temperature below $10^\circ C$ using ice.

Step 2 - Phenylamine is then reacted with the HNO_2 to form an unstable diazonium salt

Step 3 - On further warming, phenol is produced as diazonium salt is decomposed (hydrolysed).



22.6 REACTIONS OF PHENOL

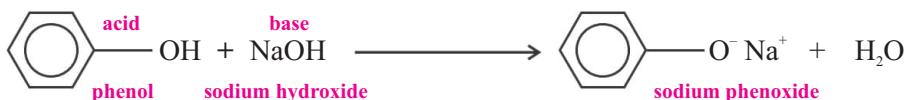
Phenols can undergo many types of reactions as both the electron-rich benzene ring and the polar OH group can participate in chemical reactions. Some of the reactions of phenols are given below.

22.6.1 Reactions of the -OH Group in Phenols

The -OH group in phenols has a slightly acidic character. It can therefore act as an acid and take part in acid-base reactions.

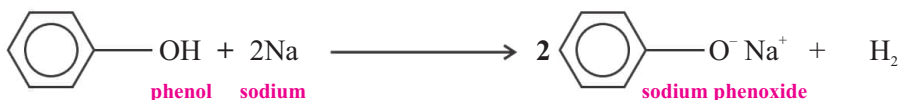
i. Reaction with bases

Phenols are only slightly soluble in water due to the large non-polar benzene ring. However, they do dissolve in alkaline solutions and undergo acid-base reactions with bases to form a soluble salt and water.



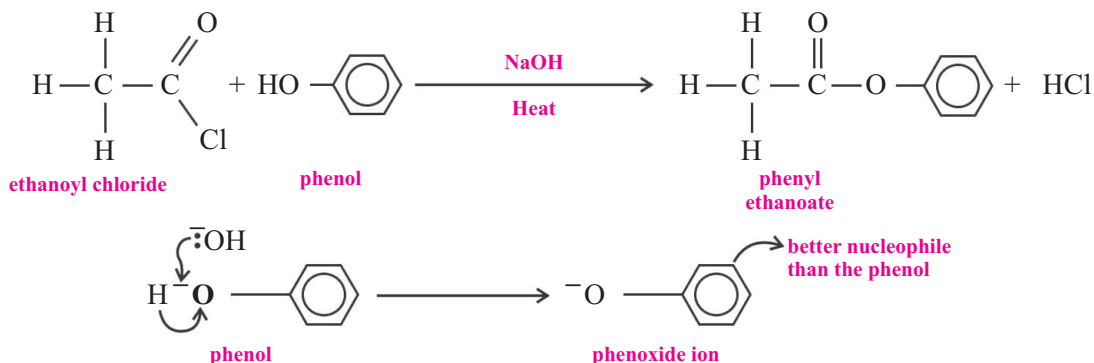
ii. Reaction with reactive metals

Molten phenols react vigorously with reactive metals such as sodium (Na). This is also an acid-base reaction. Now, a soluble salt is formed and hydrogen gas is given off.



iii. Reaction with acyl chloride

When phenol is heated with acyl chloride in the presence of a base, an ether is produced. The base is needed to deprotonate the phenol and form a phenoxide ion. The phenoxide ion is a better nucleophile than the original phenol molecule and will be able to attack the carbonyl carbon.



iv. Reaction with diazonium ions

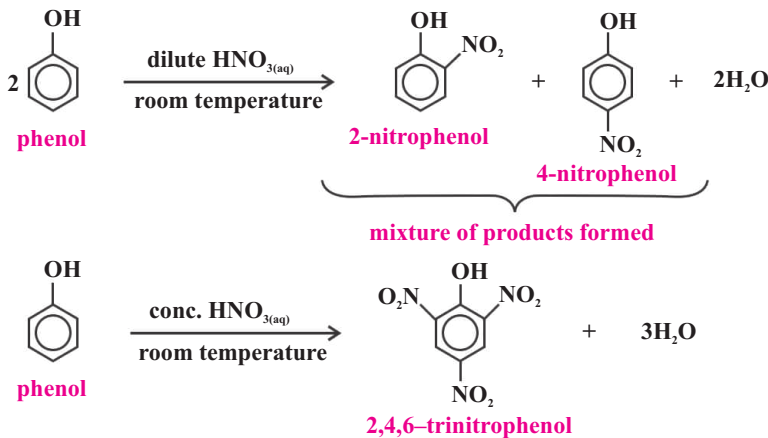
This reaction of phenol will be discussed in Chapter 24 (Organic Nitrogen Compounds).

22.6.2 Reactions of the Aromatic Ring in Phenols

Phenols consist of a hydroxyl (-OH) group attached to a benzene ring. The oxygen atom in this hydroxyl group donates electron density into the ring. One of the lone pairs of the oxygen atom overlaps with the π system of the benzene ring and becomes delocalised, causing an increased electron density in the aromatic ring. Due to the increased electron density, the benzene ring is more likely to undergo electrophilic attack and becomes activated. The incoming electrophiles are directed by the hydroxyl group of phenol to the 2, 4, and 6 positions.

i. Nitration

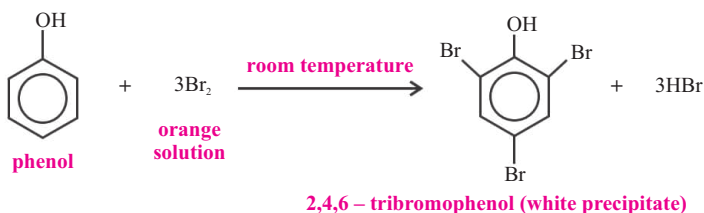
Phenols can undergo electrophilic substitution reactions when reacted with dilute nitric acid (HNO_3) at room temperature to give a mixture of 2-nitrophenol and 4-nitrophenol. When concentrated HNO_3 is used, the product will be 2,4,6-trinitrophenol instead. A hydrogen atom in the benzene ring is substituted by a nitro ($-\text{NO}_2$) group. This is known as the nitration of phenol.



The nitration of benzene requires a mixture of concentrated nitric acid (HNO_3) and sulfuric acid (H_2SO_4) refluxed with benzene between 25°C and 60°C . Since phenol is more reactive, nitration can occur under milder conditions by reacting it with dilute nitric acid at room temperature. If concentrated nitric acid is used, 2,4,6-trinitrophenol is formed.

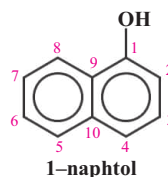
ii. Bromination

Phenols also undergo electrophilic substitution reactions when reacted with bromine water at room temperature. Phenol decolourises the orange bromine solution to form a white precipitate of 2,4,6-tribromophenol. This is also known as the bromination of phenol.



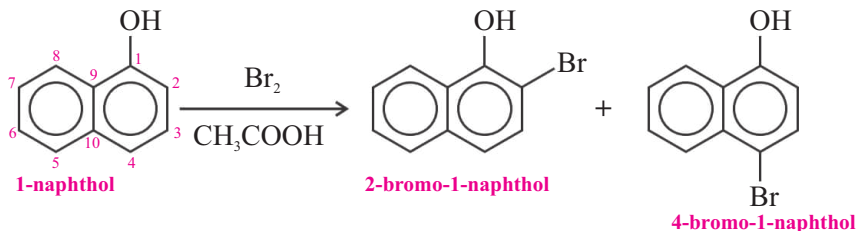
Benzene will undergo bromination only when reacted with pure bromine (not a solution) and in the presence of anhydrous aluminium bromide (AlBr_3) catalyst at room temperature. Phenol on the other hand readily reacts with bromine water in the absence of a catalyst.

There exist many phenolic compounds other than phenol ($\text{C}_6\text{H}_5\text{OH}$). An example of a phenolic compound is 1-naphthol.



1-naphthol is a phenolic compound

1-naphthol contains a hydroxy group attached to position of 1 of naphthalene. Just like with phenol, the $-\text{OH}$ group in 1-naphthol is also electron-donating and activates the naphthalene ring to electrophilic substitution reactions. The electrophiles are directed to the 2 and/or 4 positions. Substitution at the 9 and 10 positions is not possible as there is no hydrogen atom on these carbons. 1-naphthol and other phenolic compounds react in a similar way as phenol.



Quick Check 22.5



- The reaction of phenol with bromine water is used for the identification of phenol. What will be the visual change during the reaction, also give the systematic name of the compound formed.
- Nitration is an example of aromatic electrophilic substitution and its rate depends upon the group already present in the benzene ring. Out of benzene and phenol, which one is more easily nitrated and why?
- Write the reaction equation for nitration of 1-naphthol.

c) Acidified $K_2Cr_2O_7$

d) $NaOH_{(aq)}$

Q2. SHORT ANSWER QUESTIONS

a) Six alcohols are given below:

i. butan-2-ol

ii. ethane-1,2-diol

iii. 2-methylpentan-3-ol

iv. 2-methylpropan-2-ol

v. propan-1-ol

vi. propan-2-ol

i) Which alcohol is an example of a tertiary alcohol?

ii) Which alcohol is an example of an alcohol that can be oxidized to carboxylic acid?

iii) Which alcohol is an example of an alcohol that can be oxidized to a ketone?

v) Which alcohol can't change color of acidified potassium dichromate?

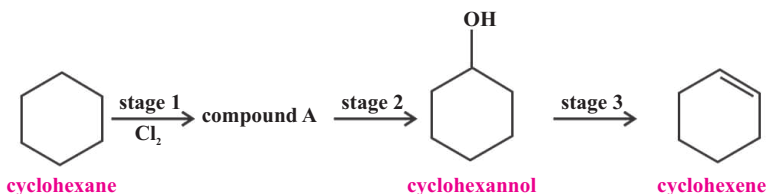
b) Phenylamine reacts with $HNO_2(aq)$ at $4^\circ C$ to form compound P. Compound P reacts with phenol under alkaline conditions at $4^\circ C$. The product of this reaction is acidified, forming azo compound Q.

i) Draw the structure of compound P and Q.

ii) Circle the azo group on your structure.

iii) State one use of an azo compound such as Q.

c) Cyclohexane can be converted into cyclohexene via a three stage synthesis.



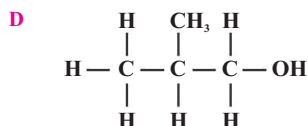
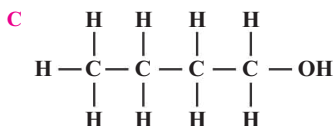
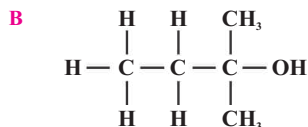
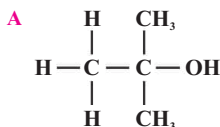
i) In stage 1, cyclohexane reacts with chlorine to form the organic product, compound A.

Show the structure of compound A.

ii) Stage 3 involves the dehydration of an alcohol. State a suitable reagent for dehydrating an alcohol.

iii) Write a balanced equation for the dehydration of cyclohexanol, $C_6H_{11}OH$.

d) There are four structurally isomeric alcohols of molecular formula $C_4H_{10}O$. Graphical formulae of these isomers, labelled A, B, C and D, are shown below.



- i) Identify the type of alcohol represented by A and by B.
 - ii) Give the name of alcohol A.
 - iii) Select one of the alcohols A, B, C or D which will, on oxidation, produce an aldehyde. Give the structural formula of the aldehyde produced by this reaction.
 - iv) All the alcohols A, B, C and D may be readily dehydrated. Explain what is meant by the term dehydration. State the type of compound formed by dehydration of alcohols.
 - v) Suggest suitable reagent(s) and condition(s) for the dehydration of alcohols.
- e) Select one of the alcohols A, B, C or D which, on dehydration, would give a single product. Draw the structural formula of this product.

Q3. CONSTRUCTED RESPONSE QUESTIONS

- I. Why nitration of phenol is easier than benzene. Which product is formed when phenol is nitrated with conc. HNO_3 at room temperature?
- ii. Sodium hydroxide reacts with phenol but not with ethanol. Give reason.
- iii. Give reactions of methanol with SOCl_2 , and PCl_5 .
- iv. How propanol can be converted into propanal?
- v. Write down the reaction for the substitution of each of Cl, Br, and I with $-\text{OH}$ in 2-propanol.
- vi. Construct a reaction for the preparation of nitro-substituted naphthol. Is there produced a single product? Explain.

DESCRIPTIVE QUESTIONS

- Q4. Explain the acidity of phenol
- Q5. Explain why the reagents and conditions for the nitration and bromination of phenol are different from those for benzene.
- Q6. Describe how phenylamine can be converted into phenol, including reagents and conditions.
- Q7. Explain why ethanol is less acidic than water, but water is less acidic than phenol.



23

CARBONYL COMPOUNDS AND CARBOXYLIC ACIDS

Student Learning Outcomes

[C-12-D-59 to C-12-D-78]

Part 1: Aldehydes and Ketones (Carbonyl Compounds)

- ⊙ State the reactions (reagents and conditions) by which aldehydes and ketones can be produced: a. the oxidation of primary alcohols using acidified $K_2Cr_2O_7$ or acidified $KMnO_4$ and distillation to produce aldehydes; b. the oxidation of secondary alcohols using acidified $K_2Cr_2O_7$ or acidified $KMnO_4$ and distillation to produce ketones.
- ⊙ Describe the use of 2,4- dinitrophenylhydrazine (2,4-DNPH reagent) to detect the presence of carbonyl compounds.
- ⊙ Deduce the nature (aldehyde or ketone) of an unknown carbonyl compound from the results of simple tests (Fehling's and Tollens' reagents; ease of oxidation).
- ⊙ Deduce the presence of a CH_3CO -group in an aldehyde or ketone, CH_3COR , from its reaction with alkaline $I_{2(aq)}$ to form a yellow precipitate of tri-iodomethane and an ion, RCO^- .
- ⊙ Describe: a. the reduction of aldehydes and ketones, using $NaBH_4$ or $LiAlH_4$ to produce alcohols; b. the reaction of aldehydes and ketones with HCN , KCN as catalyst, and heat to produce hydroxy nitriles exemplified by ethanal and propanone.
- ⊙ Describe the mechanism of the nucleophilic addition reactions of hydrogen cyanide with aldehydes and ketones.

Part 2: Carboxylic Acids

- ⊙ Recall the reactions by which carboxylic acids can be produced: a. oxidation of primary alcohols and aldehydes with acidified $K_2Cr_2O_7$ or acidified $KMnO_4$ and refluxing; b. hydrolysis of nitriles with dilute acid or dilute alkali followed by acidification; c. hydrolysis of esters with dilute acid or dilute alkali and heat followed by acidification.
- ⊙ State the reaction which benzoic acid can be produced: reaction of alkylbenzene with hot alkaline $KMnO_4$ and then dilute acid, exemplified by methylbenzene.
- ⊙ Describe the reaction of carboxylic acids with PCl_3 and heat, PCl_5 and heat, PCl_5 , or $SOCl_2$ to form acylchlorides.
- ⊙ Recognize that some carboxylic acids can be further oxidized: a) the oxidation of methanoic acid, $HCOOH$, with Fehling's reagent or Tollens' reagent or acidified $KMnO_4$ or acidified $K_2Cr_2O_7$ to carbon dioxide and water b) the oxidation of ethanedioic acid $HOOCCOOH$, with warm acidified $KMnO_4$ to carbon dioxide.
- ⊙ Describe: a. the redox reaction with reactive metals to produce a salt and $H_2(g)$; b. the neutralization reaction with alkalis to produce a salt and $H_2O(l)$; c. the acid-base reaction with bicarbonates to produce a salt and $H_2O(l)$ and $CO_2(g)$; d. esterification with alcohols with concentrated H_2SO_4 as catalyst; e. reduction by $LiAlH_4$ to form a primary alcohol.
- ⊙ Explain the relative acidities of carboxylic acids, phenols and alcohols.



- Explain the relative acidities of chlorine substituted carboxylic acids.

Part 3: Esters (Revisited and Expanded)

- Recall the reactions (reagents and conditions) by which esters can be produced: the condensation reaction between an alcohol and a carboxylic acid with concentrated H_2SO_4 as catalyst.
- Describe the hydrolysis of esters by dilute acid and by dilute alkali and heat.

Part 4: Acyl Chlorides (Acid Halides)

- Recall the reactions (reagents and conditions) by which acyl chlorides can be produced: reaction of carboxylic acids with PCl_3 and heat, PCl_5 , or SOCl_2 .
- Explain the relative ease of hydrolysis of acyl chlorides, alkyl chlorides and halogenoarenes (aryl chlorides).
- Describe the following reactions of acyl chlorides: a. hydrolysis on addition of water at room temperature to give the carboxylic acid and HCl ; b. reaction with an alcohol at room temperature to produce an ester and HCl ; c. reaction with phenol at room temperature to produce an ester and HCl ; d. reaction with ammonia at room temperatures to produce an amide and HCl ; e. reaction with a primary or secondary amine at room temperature to produce an amide and HCl .
- Describe the addition-elimination mechanism of acyl chlorides in reactions.
- Recall the reaction by which esters can be produced: reaction of alcohols with acyl chlorides using the formation of ethyl ethanoate and phenyl benzoate as examples.

23.1 CARBONYL COMPOUNDS

In organic chemistry, the structural unit $>\text{CO}=\text{}$ is known as carbonyl group. Aldehydes and ketones are the classes of compounds that contain a carbonyl group. The general structures of aldehydes and ketones are given below.

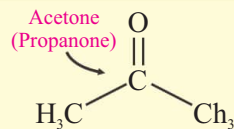
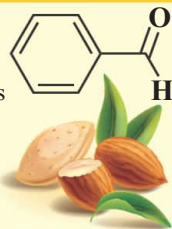
These compounds are abundant in nature and their large quantities are synthesised every year. Aldehydes are present in many spices, fruits, and natural fragrances. Ketones used in pharmaceuticals, chemicals, and paint industries. The most common ketone is acetone, which is found in nail polish removers.



MORE INFO

Interesting Information

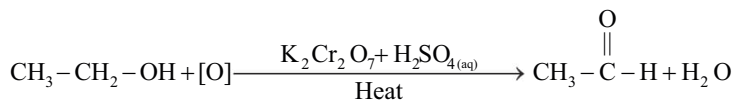
The smell and taste of bitter almond is due to benzaldehyde, which is produced due to the oxidation of terpenes.



Acetone (propanone) are used in nail polish removers

23.1.1 Preparation of Aldehydes

Aldehydes are prepared by the oxidation of primary alcohols with acidified $\text{K}_2\text{Cr}_2\text{O}_7$ or acidified KMnO_4 .



In the example of the preparation of ethanol, the acidified $K_2Cr_2O_7$ is added drop wise to the warm ethanol. The aldehyde produced is distilled off as soon as it is formed. This prevents the further oxidation of ethanal to ethanoic acids. The temperature is kept above the boiling point of acetaldehyde but below to that of ethanol, since ethanol has higher boiling point than that of acetaldehyde. Pure ethanal is obtained by redistillation. Ketones are also prepared by the same procedure from secondary alcohols but since ketones are not converted into carboxylic acids under these conditions, therefore ketone is not distilled off immediately.

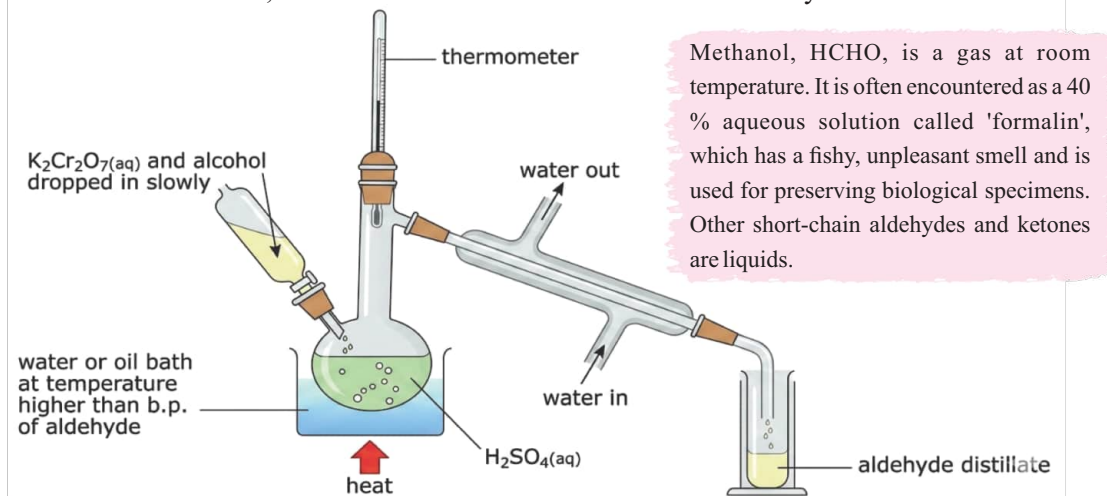
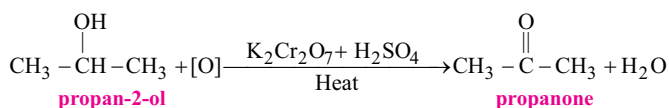


Figure 23.1 Apparatus for distilling off the ethanal as it is formed by the oxidation of ethanol.

23.1.2 Preparations of Ketones

Ketones are prepared by the oxidation of secondary alcohols.



23.2 CHEMISTRY OF CARBONYL COMPOUNDS

The carbonyl group, governs the chemistry of aldehydes and ketones. There are two basic reactions of carbonyl compounds.

- A. Nucleophilic addition reactions
- B. Alpha (α) carbon specific reactions

23.2.1 Structure and Reactivity of Carbonyl Group

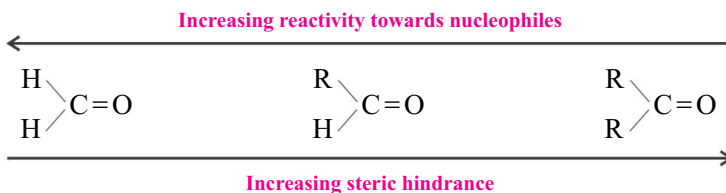
In carbonyl group, both carbon and oxygen are sp^2 hybridized. Carbon is bonded to an oxygen atom through a double bond and to other two groups through single bonds.

Carbonyl group is polar in nature because oxygen, being more electronegative, gets partial negative charge (δ^-) and carbon gets partial positive charge (δ^+). Two structural features of the carbonyl group determine the chemistry and properties of aldehydes and ketones.



- The carbonyl carbon is electrophilic in nature due to its δ^+ charge, and can be attacked by nucleophiles.
- The double bond can undergo addition reactions because π bond is easily broken down. Moreover, planar shape of the group makes the carbonyl carbon uncrowded thus giving further support to addition reactions.

Aldehydes are more reactive than ketones for two reasons. First; in a ketone, the electron releasing (inductive) effect of two alkyl groups reduces the positive charge on the carbonyl carbon making it less easily attacked by nucleophiles. Secondly, the two alkyl groups of a ketone tend to get in the way of attacking nucleophiles. This is also called steric hindrance.



Quick Check 23.1



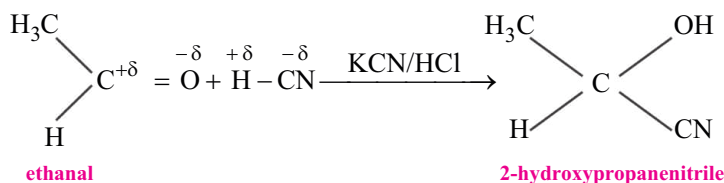
- Draw the structures for the following according to IUPAC system.
 - 2-methylbutanal
 - pentan-3-one
 - 3-methylbutenal
 - 4-methylpentan-3-one
- Name the following compounds (IUPAC) system.
 - $\text{C}_6\text{H}_5\text{-CHO}$
 - $(\text{CH}_3)_2\text{C-CHO}$
 - $(\text{CH}_3\text{CH}_2\text{CH}_2)_2\text{C=O}$
- Rank the following compounds in order of increasing reactivity towards nucleophilic attack.
 - $(\text{CH}_3)_3\text{CCOCH}_3$
 - $(\text{CH}_3)_3\text{CCOC}(\text{CH}_3)_3$
 - $(\text{CH}_3)_2\text{CO}$

23.3 REACTIONS OF CARBONYL COMPOUNDS

23.3.1 Nucleophilic addition reactions

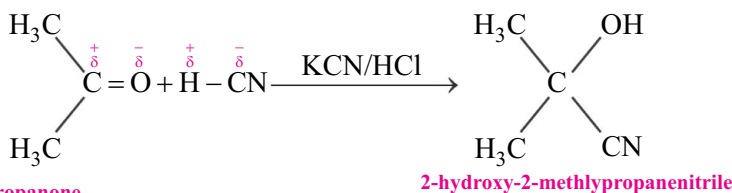
1. Addition of Hydrogen Cyanide (H-CN)

Aldehydes and ketones react with hydrogen cyanide to form cyanohydrins. HCN itself is not used directly as it is an extremely poisonous gas. Instead, it is produced by adding slowly a mineral acid (HCl) to a mixture of aqueous solution of sodium cyanide or potassium cyanide and the carbonyl compound.



2-Hydroxy-2-ethylpropanenitrile is used as an intermediate in the manufacture of Perspex, a very fine coloured-glass polymer.

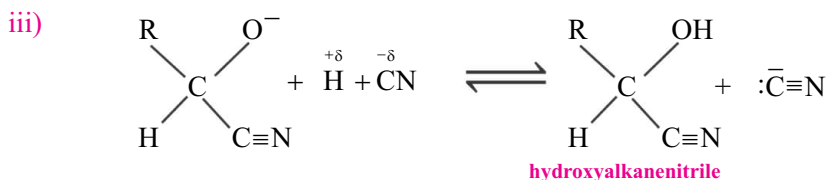
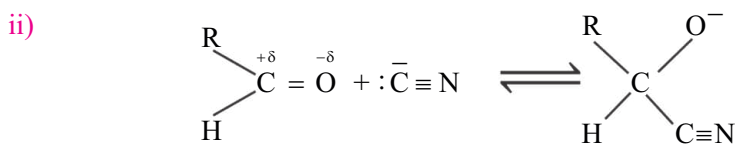
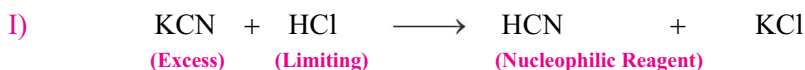




Mechanism

HCN is obtained by adding a controlled amount of an acid to a mixture of KCN and the carbonyl compound. The reaction between KCN and HCl produces HCN. HCN is neither a nucleophile (absence of a lone pair on the carbon atom) nor a strong acid to be ionized to a reasonable extent. Therefore it does not produce enough nucleophile (CN^-) to start a reaction and complete the reaction in a shorter time. This is done by adding a slight excess of KCN, so that there are some free CN^- ions in the solution. These free ions start the reaction and catalyse it to move at a reasonable rate.

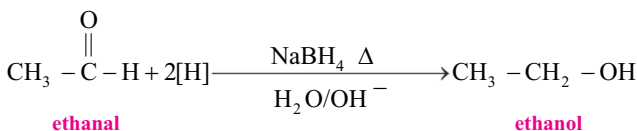
Hence,



Although both the steps involved in cyanohydrin formation are reversible, the equilibria lie far to the right. Most of carbonyl compounds giving high yields of cyanohydrins at the equilibrium. Nitriles are hydrolysed by dilute acid or aqueous alkali to form carboxylic acids or carboxylate ions; this will be discussed later.

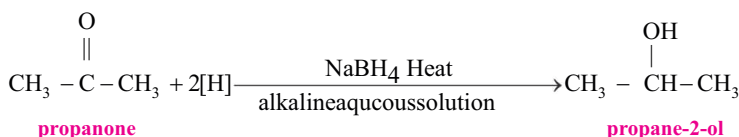
2. Addition of hydride ion (H⁻)

Since aldehydes and ketones are synthesised by oxidation of alcohols, alcohols can be produced by the reduction of aldehydes and ketones. With a reducing agent such as NaBH_4 or LiAlH_4 , aldehydes give primary alcohols and ketones gives secondary alcohols.

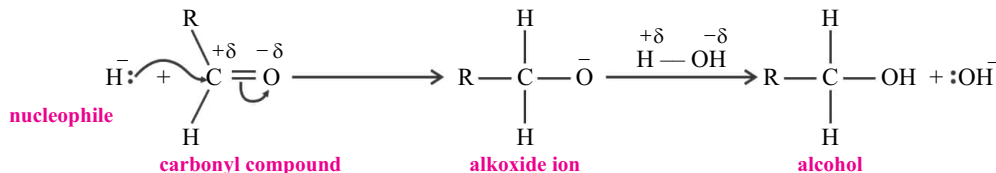


Notice that reducing H in brackets [] comes from NaBH_4 to balance the equation. It does not represent atomic hydrogen.



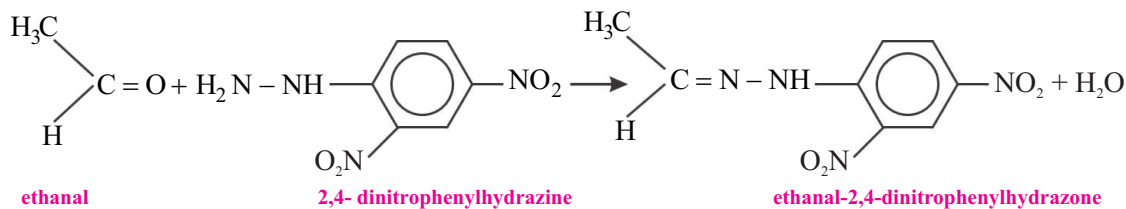


Mechanism



3. Addition of 2,4-Dinitrophenylhydrazine (Addition – elimination / Condensation Reaction)

Aldehydes or ketones undergo a condensation reaction with 2,4-dinitrophenylhydrazine (2,4-NDPH) to give an orange crystalline solids with well-defined melting points.



This reagent is used to identify carbonyl compounds. For example, ethanal reacts with 2,4-NDPH to form orange crystals of 2,4-dinitrophenylhydrazone. Other classes of organic compounds like carboxylic acids, esters, acyl halides, amides etc which also contain the carbonyl group >C=O do not give this test.

23.3.2 Test of aldehydes and ketones

Aldehydes and ketones are oxidized to form carboxylic acids. Aldehydes are easily oxidized whereas ketones are reluctant towards oxidation because C-C bond has to be broken down during oxidation. Therefore, ketones are only oxidized by strong oxidizing agents, whereas aldehydes are oxidized by both weak and strong oxidizing agents.

i) Tollen's test

Tollen's reagent also called ammonical silver nitrate solution contains silver ions in aqueous alkaline solution. These silver ions are readily reduced to silver metal on gentle warming with an aldehyde. A silver mirror is formed along the wall of the test tube. A dilute solution of the glucose (aldehydic sugar) was used to make mirrors for domestic use by means of this reaction. Ketones do not give this test.

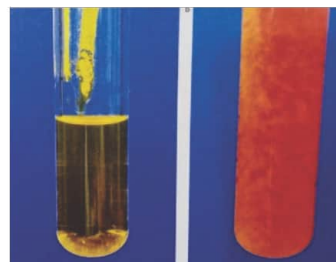


Figure 23.2: Ethanal gives orange crystalline 2,4-DNPH



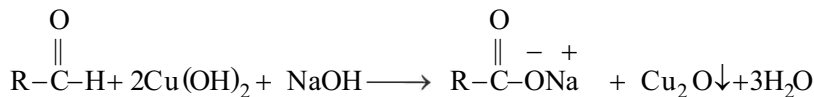
Fig.23.3 Only aldehydes give a positive Tollen's test





ii. Fehling's solution Test

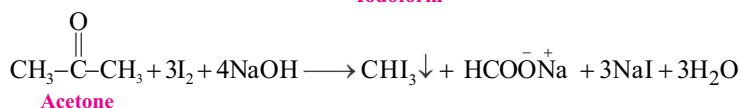
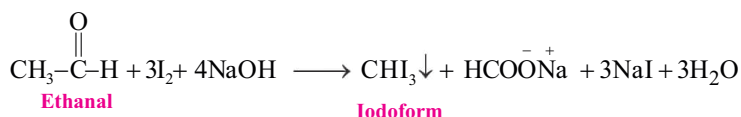
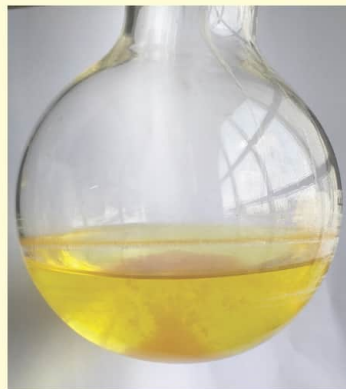
Fehling's solution is the bright blue Fehling's solution of Cu^{2+} ions in an aqueous alkaline medium, complexed with salt of tartaric acid. When warmed with an aldehyde, the Cu^{2+} ions are reduced to Cu^{+} ions, which in the alkaline solution form a brick-red precipitate of copper (I) oxide. Ketones do not give this test.



iii. Iodoform Test

Aldehydes and ketones undergo substitution reactions by halogens readily at alpha position. Among aldehydes, only ethanal and among ketones, only methyl ketones possess the group CH_3CO - known as acetyl (ethanoyl) group. These compounds react with iodine in the presence of sodium hydroxide to form triiodomethane, a yellow crystalline solid called iodoform. Hence, the appearance of yellow precipitates will identify the presence of CH_3CO - group in the unknown carbonyl compound.

Aldehydes and Ketones having CH_3CO group, whereas alcohols having $\text{CH}_3\text{-CH(OH)}$ group give iodoform test. Yellow coloured iodoform is formed in this reaction.



Ethanol also gives this test, while methanol does not. The reason for this is the presence of $\text{CH}_3\text{-CH}_2\text{-O}$, which acts as a methyl ketone-like structure ($\text{CH}_3\text{-C=O}$). Thus it can also form iodoform, and the test is positive for ethanol.



Quick Check 23.2

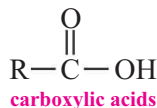


- If compound A has the molecular formula $\text{C}_3\text{H}_6\text{O}$, it reacts with NaBH_4 to give compound B, $\text{C}_3\text{H}_8\text{O}$. Both A and B give a yellow precipitate with I_2/NaOH . Identify both compounds (A & B).
- Why methanol does not give iodoform test while ethanol does?
- Describe a test (a different one in each case) that you could use to distinguish between the following pairs of compounds. $\text{CH}_3\text{CH}_2\text{CHO}$
 - $\text{CH}_3\text{CH}_2\text{CHO}$ and CH_3COCH_3
 - $\text{CH}_3\text{CH}_2\text{COCH}_2\text{CH}_3$ and $\text{CH}_3\text{CH}_2\text{CH}_2\text{COCH}_3$
 - $\text{CH}_2=\text{CH}-\text{CH}_2-\text{OH}$ and $\text{CH}_3\text{CH}_2\text{CHO}$



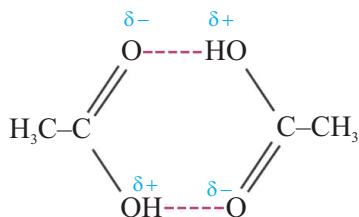
23.4 CARBOXYLIC ACIDS

Carboxylic acids are the organic compounds having the carboxyl functional group (-COOH) in their molecules. The general structure of carboxylic acids is as below.

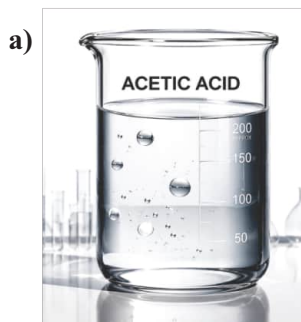


Common examples of carboxylic acids are methanoic acid (formic acid, found in ants) ethanoic acid (acetic acid, found in vinegar), and butanoic acid (butyric acid, in the rancid butter).

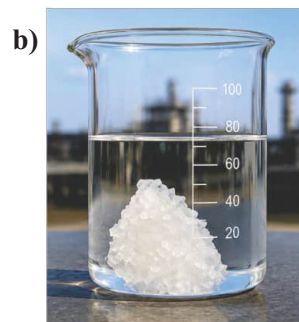
Lower carboxylic acids are generally liquids at room temperature, having high boiling points. This is due to their ability to make the hydrogen bond. The melting point of ethanoic acid is 17 °C, and its boiling point is 118 °C. The melting point of this acid is close to room temperature (25 °C), this is why it solidifies in winter. The solid form of pure ethanoic acid is called glacial acetic acid due to its resemblance with glaciers. Due to their ability to form the hydrogen bond, lower acids, i.e. methanoic acid and ethanoic acid are soluble in water.



Dimeric form of acetic acid formed due to the hydrogen bonding



Left: (a) acetic acid at room temperature



Right: (b) Glacial acetic acid at temperature below the room temperature

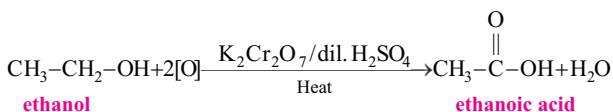
Long chain aliphatic monocarboxylic acids are called fatty acids. Stearic acid, palmitic acid, and oleic acid are found in vegetable oils in the form of triglycerides. They are insoluble in water due to their long hydrophobic alkyl chains.

23.4.1 Preparation of Carboxylic Acids

Carboxylic acids can be prepared by the following methods.

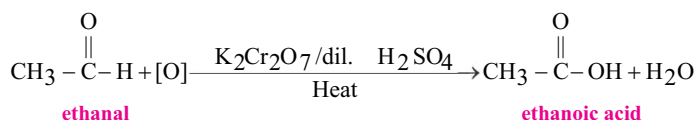
a) Oxidation of primary alcohols and aldehydes

Carboxylic acids are prepared by the oxidation of primary alcohols and aldehydes. The starting material is refluxed with excess of either acidified KMnO_4 or acidified $\text{K}_2\text{Cr}_2\text{O}_7$.



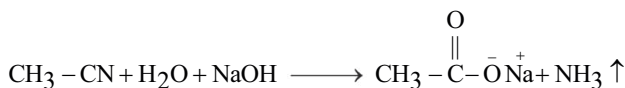
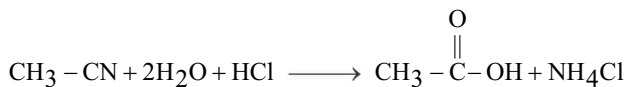
Palmitic acid ($\text{C}_{16}\text{H}_{32}\text{O}_2$) is a long chain carboxylic acid found in palm oil in large quantities





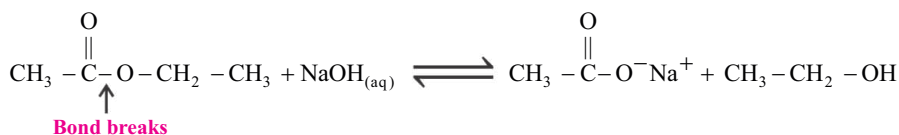
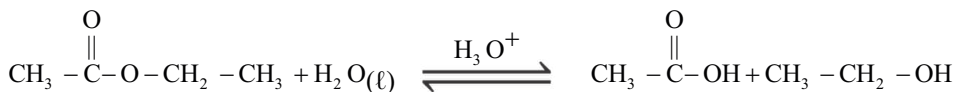
b) Hydrolysis of alkane nitriles

Alkane nitriles can be directly hydrolysed to carboxylic acids in acidic medium. In alkaline hydrolyses, they first produce salts of carboxylic acids, which yield carboxylic acids on acidification.



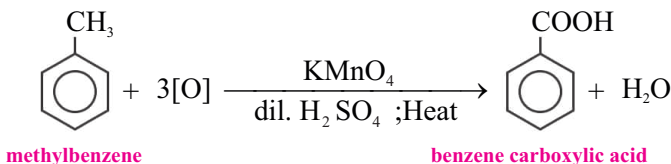
c) Hydrolysis of esters

When an ester is refluxed with either dilute acid or dilute alkali, the ester is hydrolyzed to carboxylic acid or carboxylate ion.



d) Preparation of benzenecarboxylic acid (Benzoic acid)

Methyl benzene is readily oxidized by acidified KMnO_4 or $\text{K}_2\text{Cr}_2\text{O}_7$ to benzoic acid.



Quick Check 23.3



- Write the equation for the oxidation of propanol with acidified $\text{K}_2\text{Cr}_2\text{O}_7$?
- What products you expect from following? Give the chemical equations.
 - Hydrolysis of $\text{CH}_3\text{CH}_2\text{CN}$
 - Oxidation of ethylbenzene
 - Hydrolysis of ethyl ethanoate



23.5 REACTIONS OF CARBOXYLIC ACIDS

Reactions of carboxylic acids can be divided into the following types.

- Reactions involving the acidic hydrogen only.
- Reactions involving the replacement of the $-OH$ group.
- Those involving the carboxyl group as a whole.

A. Reaction involving acidic hydrogen

Carboxylic acids show considerable acidic character because they give H^+ ions in water. This why they can react with the basic species and active metals.

a) With active metals



b) With alkalis



c) With metal carbonates and bicarbonates



B. Reactions involving replacement of $-OH$ group

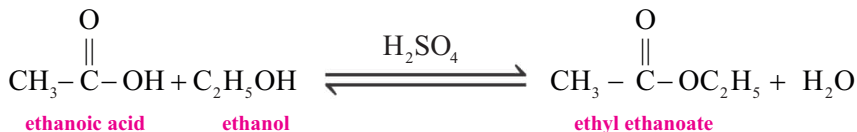
Carboxylic acids can undergo substitution reactions in which the OH group is replaced by some other group like X , OR , NH_2 etc.

a) Reaction with $SOCl_2$, PCl_3 and PCl_5



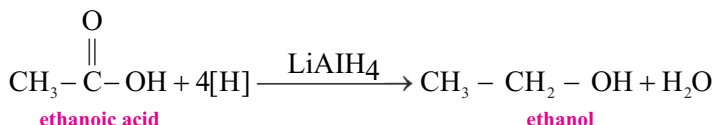
b) Reaction with alcohols (Esterification)

Carboxylic acids on heating with alcohols in the presence of concentrated sulphuric acid produce esters.



C. Reduction involving $\text{C}=\text{O}-\text{OH}$ group

The powerful reducing agent lithium tetrahydridoaluminate (III) reduces carboxylic acids to primary alcohols.



Reduction

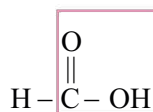
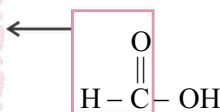
- i. Gain of H_2 (or H^-)
- ii. Loss of O or O_2
- iii. Loss of X_2 (Halogens)
- iv. Gain of electrons
- v. Decrease in Ox state.

Other common reducing agents H_2/Ni and sodium tetrahydridoborate (III) will not reduce carboxylic acids.

Oxidation of carboxylic acids

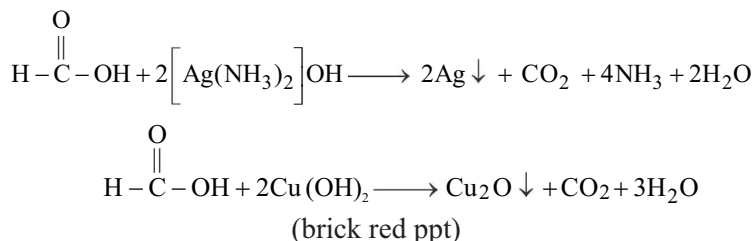
Methanoic acid gets oxidized with both weak as well as strong oxidizing agents due to its structure and, hence, acts as a strong reducing agent.

Aldehydic portion
(-CHO) responsible
for its behaviour as
a powerful
reducing agent.



Carboxylic portion
(-COOH)
responsible for its
acidic character.

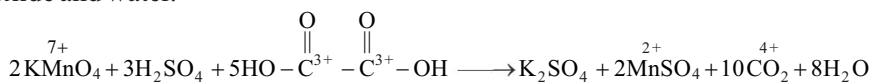
Methanoic acid is the only monocarboxylic acid which gives positive silver mirror test (Tollen's test) and brick red precipitates with Fehling's solution. These reactions are used for the identification of methanoic acid.



Oxidation

1. Loss of H_2 or (H)
2. Addition of O or O_2
3. Addition of X_2
4. Loss of electrons
5. Increase in Ox. State

The oxidation of ethanedioic acid with acidified KMnO_4 or $\text{K}_2\text{Cr}_2\text{O}_7$ results in the formation of carbon dioxide and water.



23.6 RELATIVE ACIDITIES OF CARBOXYLIC ACIDS

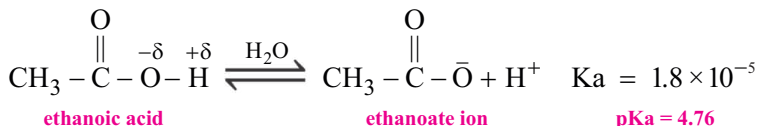
Carboxylic acids are considerably more acidic than phenols and phenols are even more acidic than alcohols. The relative values of acidity constant or ionization constant, K_a , are given below (table) for a carboxylic acid, phenol or an alcohol.

The acidic strength i.e., extent of ionization of an acid depends upon the stability of its conjugate base. For example,

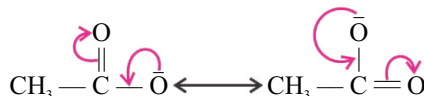


Table 23.1

Substance	K _a	pK _a
RCOOH	10 ⁻⁵	5
ArOH	10 ⁻¹⁰	10
HOH	10 ⁻¹⁴	14
R-OH	10 ⁻¹⁶	16

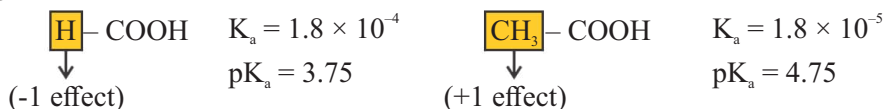


In the ethanoate ion (the conjugate base), the intensity of the negative charge on oxygen atom is decreased due to delocalization of electrons around the -COOH group. Due to this, the ethanoate ion becomes stabilized thus making it less likely to accept H⁺ ions to form undissociated acid molecule.

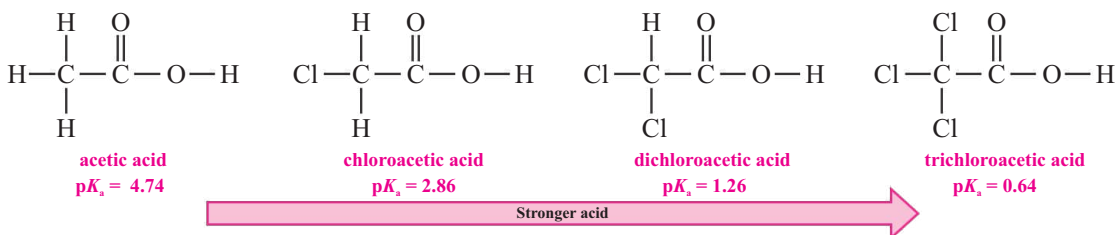

pK_a = -log K_a

Higher the K_a or lower the pK_a, stronger will be the acid and vice versa.

The presence of an electron donating group (+I effect) will tend to destabilize the carboxylate ion by intensifying the negative charge and thus decreases the acidity of the acid. On the other hand, an electron withdrawing group (-I effect) will tend to stabilize the carboxylate ion by dispersing its negative charge and thus increases the acidity of the acid. For example, methanoic acid is 10 times stronger acid than ethanoic acid.



For example, chloroacetic acid (ClCH₂-COOH) has a pK_a of 2.86, indicating that it is a stronger acid than ethanoic acid (pK_a = 4.74). Dichloroethanoic acid (Cl₂CH-COOH) is stronger, with a pK_a of 1.26. Trichloroacetic acid (Cl₃C-COOH) has a pK_a of 0.64, comparable in strength to some mineral acids.


Quick Check 23.4


- Methanoic acid is stronger than ethanoic acid. Give reason.
- Place the following acids in order of strength, starting with the strongest acid first.
 - CH₃CH₂COOH
 - CH₃CCl₂COOH
 - CH₃CHClCOOH
- Explain why ethanoic acid is a stronger acid than ethanol.

23.7 ESTERS

Esters are the derivatives of carboxylic acids that are obtained by their reactions with alcohols. Esters, unlike alcohols and carboxylic acids have no ability to form the hydrogen bond. This is



why their boiling points are lower than the corresponding alcohols and carboxylic acids. The b.p of ethyl ethanoate ($\text{CH}_3\text{COOC}_2\text{H}_5$) is 77°C , which shows its lower relative volatility compared to ethanoic acid and ethanol. Lack of hydrogen bonds makes esters less soluble/insoluble in water. Many esters are liquids with sweet fruity smells. Esters find many uses as solvents and flavouring agents in fruit drinks and sweets. Volatile esters are liquids with sweet fruity smells. Esters find many uses as solvents and flavouring agents in fruit drinks and sweets.



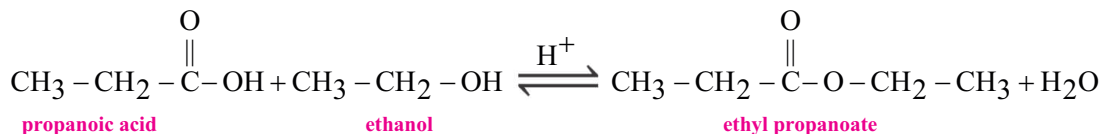
Fragrance of fruits and their tastes are due to esters

23.7.1 Preparations of Esters

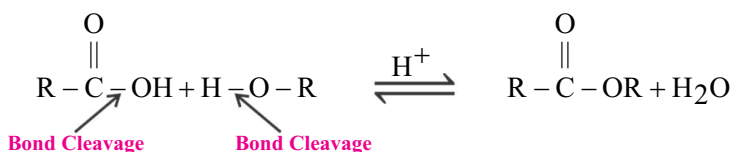
Esters can be prepared by the following methods.

i. By the reaction of carboxylic acids and alcohol

The reaction of carboxylic acids with alcohols in acidic medium results in the formation of an ester. This reaction is known as Fischer's esterification. For example,

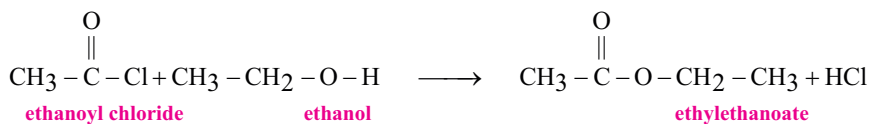


In general



iii. By the reaction of acyl chlorides and alcohols

Acyl chlorides react vigorously with alcohols to form esters and their reactions go to completion and do not form an equilibrium mixture like the reaction between carboxylic acids and alcohols.



iv. By the reaction of acyl Chlorides and phenol

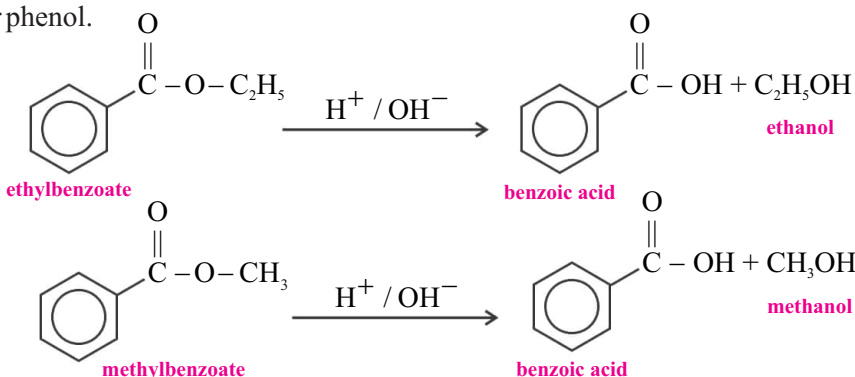
Phenyl esters are formed when acyl chloride is warmed with phenol. The reaction is already discussed in Chapter 22.



23.7.2 Reactions of Esters

i) Hydrolysis of esters

An ester is hydrolyzed slowly to a carboxylic acid and an alcohol (or a phenol). The reaction is either acid or base-catalyzed. The hydrolysis of aliphatic esters is already discussed earlier in this chapter. Aromatic esters are also hydrolysed in the same manner, giving aryl carboxylic acids and alcohols or phenol.



23.8 ACYL CHLORIDES

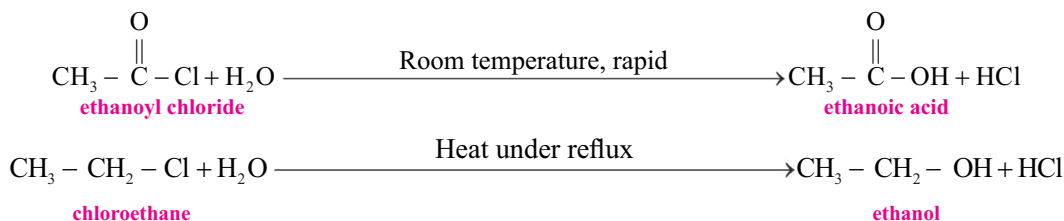
Acyl chlorides have the functional group $\text{C}(=\text{O})\text{Cl}$. Saturated aliphatic acyl chlorides have the general formula $\text{C}_n\text{H}_{2n+1}\text{COCl}$. According to the IUPAC system, they are named as alkanoyl halides. For example

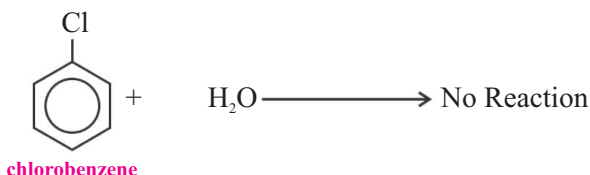


Since acyl chlorides are the most reactive compounds among the functional derivatives of carboxylic acids, they are usually prepared in such a way that they can be used for the preparation of other functional derivatives.

23.9 HYDROLYSIS OF ACYL CHLORIDES, ALKYL CHLORIDES AND ARYL CHLORIDES

The reactivity of acyl chlorides, alkyl chlorides and aryl (arene) chlorides can be compared with the ease of hydrolysis they undergo. Let us consider the following reactions.





In ethanoyl chloride, the carbonyl carbon is having partial positive charge due to the strong electron withdrawing effect of two highly electronegative atoms: oxygen and chlorine directly attached to the carbon. Hence nucleophilic attack of H_2O on electrophilic carbon is so fast that reaction is completed within few minutes.

In ethyl chloride, the carbon gets comparatively less partial positive charge because it is attached to only chlorine atom. So, the nucleophilic attack of water is comparatively slow and takes 14 days to be completed even at 100°C .

On the other hand in chlorobenzene, the carbon bonded to chlorine is the part of benzene ring. Here, lone pair on chlorine participates in delocalization with π electrons of the benzene ring. This will create a double bond character in C-Cl bond making it so strong that it will not break and, hence, does not take part in the chemical reaction.



Quick Check 23.5



- Why do phenols not react directly with carboxylic acids to form phenyl esters?
- Phenyl ethanoate is the ester responsible for the fragrance of peach and strawberry. It can be prepared from the ethanoyl chloride and phenol. Write down a chemical reaction for the preparation of this ester.
- Predict the products of the following reactions, write the chemical equations.
 - Chlorobenzene and ethanol
 - Propanoyl chloride and phenol

Exercise



Q1. Multiple Choice Questions:

I. Ketones are prepared by the oxidation of alcohols:

- | | |
|-------------|---------------|
| a) Primary | b) Secondary |
| c) Tertiary | d) Quaternary |

II. Which of the following will not give the iodoform test?

- | | |
|---------------------|----------------|
| a) Acetaldehyde | b) 2-pentanone |
| c) 3-Pentanoic acid | d) Acetone |

III. When a carboxylic acid reacts with an alcohol, the product is an:

- | | |
|--------------|----------|
| a) Ethers | b) Ester |
| c) Anhydride | d) Amide |



IV. Carboxylic acids react with carbonates to produce gas.

- | | |
|-----------|-----------|
| a) H_2 | b) CO |
| c) CO_2 | d) CH_4 |

V. Which type of alcohols produces aldehydes?

- | | |
|-------------|------------------|
| a) Primary | b) Secondary |
| c) Tertiary | (d) both a and b |

VI. The hybridization of the oxygen of carbonyl group is:

- | | |
|-----------|------------|
| a) sp | b) sp^2 |
| c) sp^3 | d) dsp^2 |

VII. Which is the main product of the reaction between acetic acid and PCl_5 .

- | | |
|--------------|---------------|
| a) CH_3-Cl | b) CH_3COCl |
| c) HCl | d) $POCl_3$ |

VIII. Acidic character of chlorine substituted carboxylic acid is higher because chlorine is:

- | | |
|----------------------------------|-------------------------------------|
| a) Electropositive | b) Electron withdrawing due to $-I$ |
| c) Electron donating due to $+I$ | d) having three lone pairs |

IX. When formic acid is oxidized, which of the following is formed?

- | | |
|-----------------------------|--------------------|
| a) water | b) carbon dioxide |
| c) carbon dioxide and water | d) carbon monoxide |

X. The mechanism by which acyl chlorides react with alcohols is.

- | | |
|-------------------------|-----------------|
| a) Addition | b) Elimination |
| c) Addition-elimination | d) Substitution |

Q2. Attempt the following short answer questions:

- How is ethanol converted to acetic acid?
- Give the mechanism for the reductions of ethanal with $NaBH_4$.
- What is iodoform reaction?
- Methanoic acid can be oxidized but other carboxylic acids cannot. Why?
- Explain the influence of chlorine substitution on the acidity of carboxylic acids.
- Give the reaction of acyl chloride with phenol.
- Explain why carboxylic acid is more acidic than ethanol.
- Give reaction of methanal with the Tollen's reagent.
- Write down structural formulae of the following compounds.

i) 2-methylhexanal	ii) 2-methyl-3-pentanone
iii) 3-hydroxypentanol	iv) 4-nitro-2-pentanone
- 2-chlorobutanol



Q3. CONSTRUCTED RESPONSE QUESTIONS:

- Write down the equation for the reaction of $\text{CH}_3\text{CH}_2\text{-CHO}$ with LiAlH_4 (dry ether).
- An alcohol, $\text{C}_4\text{H}_{10}\text{O}$ undergoes oxidation to form a carboxylic acid, $\text{C}_4\text{H}_8\text{O}_2$. Give a chemical equation along with conditions.
- Write the structures of all the isomeric alcohols with formula $\text{C}_4\text{H}_{10}\text{O}$. Give their systematic names. Which one of them forms the above carboxylic acid? Explain why the others do not.
- Propanoic acid can be reduced to propan-1-ol by reduction with LiAlH_4 . Give a balanced chemical equation. Can we use NaBH_4 for this reaction? If not, give reason.

DESCRIPTIVE QUESTIONS:

- Q4.** What are aldehydes and ketones? Give the preparation of each.
- Q5.** Give four methods for the preparation of carboxylic acids.
- Q6.** How does ethanoic acid reacts with:
- | | |
|----------------------|--------------------|
| i) NaOH | ii) ethanol |
| iii) SOCl_2 | iv) PCl_5 |
- Q7. Give the mechanisms of the reactions of carbonyl compounds with:**
- | | |
|-----------------|--------------------|
| i) HCN | b) NaBH_4 |
|-----------------|--------------------|
- Q8.** Explain the relative acidities of chlorine substituted carboxylic acids.
- Q9.** Explain the relative ease of hydrolysis of acyl chlorides, alkyl chlorides and halogenoarenes.



24

ORGANIC NITROGEN
COMPOUNDS

Student Learning Outcomes

[C-12-D-79 to C-12-D-97]

⊙ **Part 1: Amines - Fundamentals and Classification**

- ⊙ Define primary and secondary amines, and explain their basic properties and reactivity.
- ⊙ Identify the differences between primary and secondary amines in terms of their structure and chemical properties.
- ⊙ Define the basicity of aqueous solutions of amines.

⊙ **Part 2: Synthesis of Amines and Related Nitriles**

- ⊙ Describe the reactions by which nitriles can be produced: reaction of a halogenoalkane with KCN in ethanol and heat.
- ⊙ Recall the reactions by which hydroxy nitriles can be produced: the reaction of aldehydes and ketones with HCN, KCN as catalyst, and heat.
- ⊙ Describe the hydrolysis of nitriles with dilute acid or dilute alkali followed by acidification.
- ⊙ Describe the preparation methods of primary and secondary amines, including nucleophilic substitution reactions and reduction of nitro compounds.
- ⊙ Recall the reactions (reagents and conditions) by which primary and secondary amines are produced: a) reaction of halogenoalkanes with NH_3 in ethanol heated under pressure; b) reaction of halogenoalkanes with primary amines in ethanol, heated in a sealed tube / under pressure. c) The reduction of amides with LiAlH_4 ; d) The reduction of nitriles with LiAlH_4 or H_2/Ni .

⊙ **Part 3: Phenylamine and Azo Compounds (Aromatic Amines)**

- ⊙ Explain the relative basicity of aqueous ammonia, ethylamine and phenylamine.
- ⊙ Explain the properties and reactivity of phenylamine and azo compounds, including their use as dyes and pigments.
- ⊙ Define the reaction of phenylamine with $\text{Br}_{2(\text{aq})}$ at room temperature.
- ⊙ Define the reaction of phenylamine with HNO_2 or NaNO_2 and dilute acid below 1°C to produce the diazonium salt; further warming of the diazonium salt with H_2O to give phenol.
- ⊙ Identify the properties of azo compounds (some examples include: a) Describe the coupling of benzene-diazonium chloride with phenol in $\text{NaOH}_{(\text{aq})}$ to form an azo compound; b) Identify the azo group; c) State that azo compounds are often used as dyes; d) Recognize that other azo dyes can be formed via a similar route).

⊙ **Part 4: Amides and Amino Acids**

- ⊙ Identify the reactions (reagents and conditions) by which amides are produced (some examples include: a) The reaction between ammonia and an acyl chloride at room temperature; b) The reaction between a primary amine and an acyl chloride at room temperature).
- ⊙ Describe the reactions of amides (some examples include: a) Hydrolysis with aqueous alkali or



aqueous acid; b) The reduction of the CO group in amides with LiAlH_4 to form an amine).

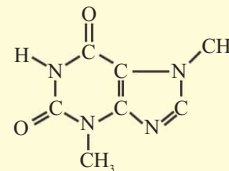
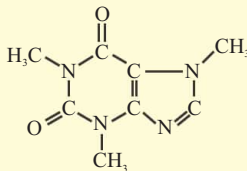
- Explain why amides are much weaker bases than amines.
- Describe the acid / base properties of amino acids and the formation of zwitterions.
- Describe the formation of amide (peptide) bonds between amino acids to give di- and tripeptides.
- Predict the results of electrophoresis on mixtures of amino acids and dipeptides at varying pHs.

Organic nitrogen compounds are essential to life and the modern world. They form the basis of life in the form of amino acids and nucleotides, making the most vital compounds for life, i.e. proteins. Amines and nitro compounds have the pivotal significance in the dye industry and medicines. Nylon, Kevlar[®], and polyurethane are the nitrogen containing polymers, which are found in every home and office. Apart from these, nitrogen compounds are also part of our food, fertilisers, explosives, etc.

MORE INFO

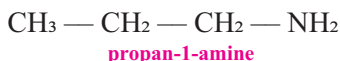
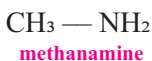
Interesting Information

Caffeine in coffee and theobromine in chocolate both are organic nitrogen compounds. These are active compounds that make our mode happy. What is the difference between these two?



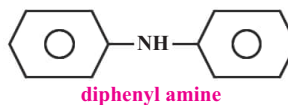
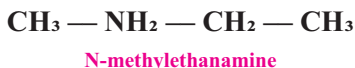
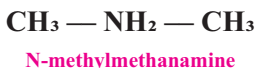
24.1 AMINES

Amines are considered as organic derivatives of ammonia, where alkyl or aryl groups may replace one, two or three hydrogen atoms of ammonia. The number of hydrogen atoms replaced by alkyl or aryl groups provides a foundation for the classification of amines as primary, secondary and tertiary amines. In the primary amines one alkyl or aryl group is attached to $-\text{NH}_2$ group. In IUPAC nomenclature system, amines are referred to as alkanamines.

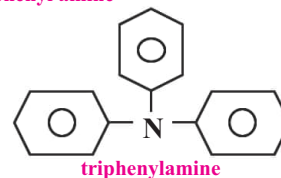
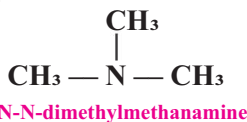


phenylamine (aniline)

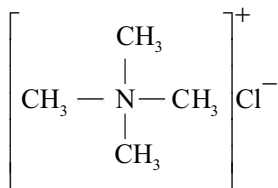
In secondary amines, two alkyl or aryl groups are attached to NH group e.g.



In tertiary amines, three alkyl or aryl groups are attached to the same nitrogen atom e.g.



Tetra-substituted nitrogen derivatives are also known, and are termed as quaternary ammonium salts e.g.



tetramethylammonium chloride

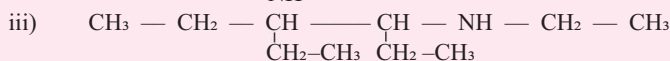
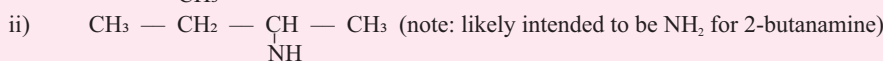
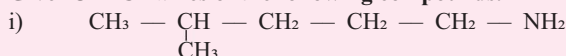
It is important to note that the branching takes place at the nitrogen atom, rather than at the carbon atom attached to it, that determines whether an amine is primary, secondary or tertiary. This is not the same as in the case of the alcohols or monohaloalkanes (alkyl halides).



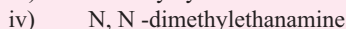
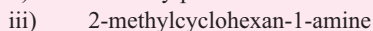
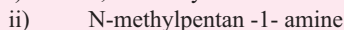
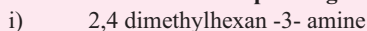
Quick Check 24.1



a) Give IUPAC names of the following compounds.



b) Draw a structure corresponding to each amine.

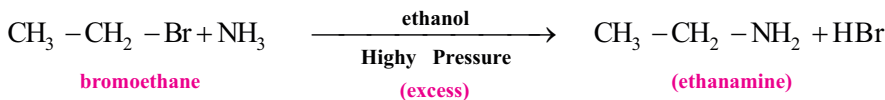


24.2 PREPARATION OF AMINES

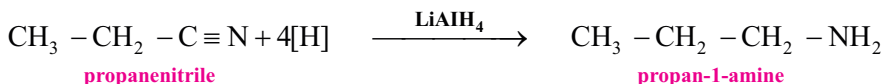
A) Aliphatic Primary Amines

i) Primary amines can be prepared by the nucleophilic substitution reactions of halogenoalkanes with ammonia. Excess of ethanolic ammonia under pressure is used to avoid the formation of secondary amines or a mixture of products.

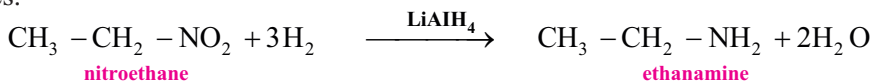
If NH_3 is in excess, the major product will be primary amine and if halogenoalkane is in excess, tertiary amine is the major product.



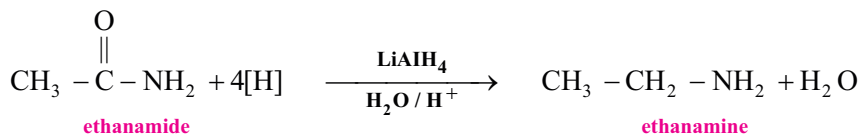
ii) Primary amines are prepared by the reduction of alkanenitriles. For example, propanenitrile is reduced with H_2/Ni or LiAlH_4 to prepare propan-1-amine



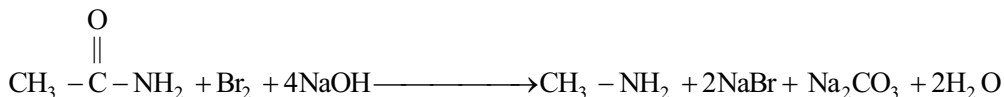
iii) Nitroalkanes are reduced in the presence of LiAlH_4 resulting in the formation of primary amines.



- iv) Alkanamides are reduced by LiAlH_4 to form primary amines in good yield since no byproduct is formed in this reaction.



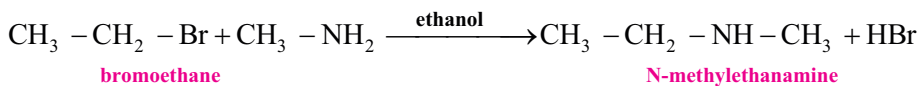
- v) Primary alkanamine can also be prepared by the Hofmann reaction.



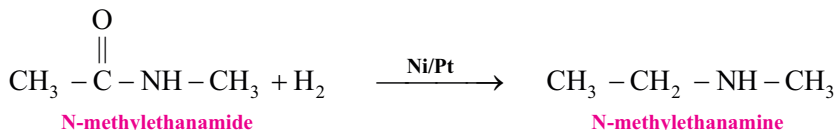
This reaction yields the amine with one carbon less than the starting amide.

B) Aliphatic Secondary Amines

- i) Secondary amines can be prepared by the alkylation of primary amines. When a halogenoalkane reacts with a primary amine in the presence of ethanol under pressure secondary amine is formed.

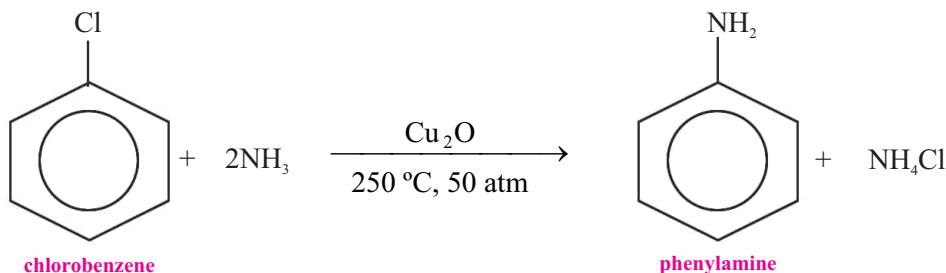


- ii) Secondary amines are also prepared by the reduction of N-substituted amides

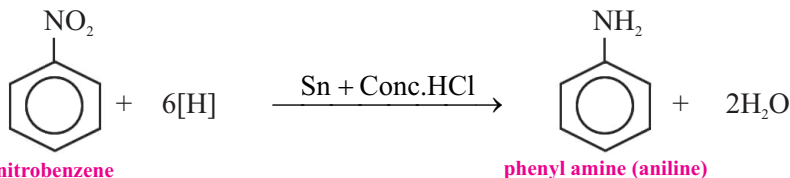


C) Phenyl Amine (Aromatic Amine)

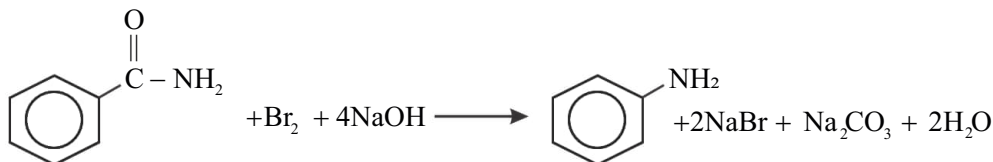
- i. Phenyl amine can be prepared by ammonolysis of chlorobenzene. Ammonolysis is a reaction in which an ammonia molecule is broken down to react with another compound.



iii. Phenyl amine can also be prepared by the reduction of nitrobenzene.



iv. Phenyl amine can be prepared by the Hofmann reaction.



Quick Check 24.2

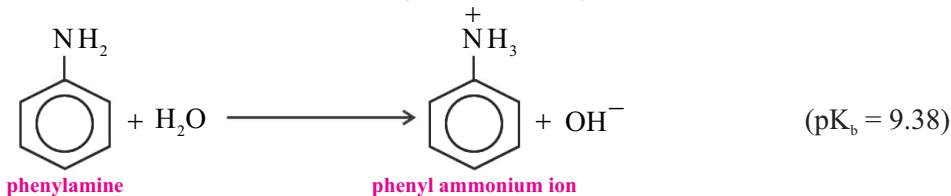
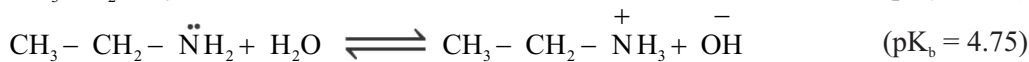


- a) The “feel good factor” in chocolate has been identified as 2-phenylethanamine, $\text{C}_6\text{H}_5\text{CH}_2\text{CH}_2\text{NH}_2$. Suggest a synthesis of this compound from chloromethylbenzene, $\text{C}_6\text{H}_5\text{CH}_2\text{Cl}$.
- b) What nitro compound, nitrile and amide are reduced to yield each of the following amine compound?
- i) For the primary amine: $\text{CH}_3 - \underset{\text{CH}_3}{\text{CH}} - \text{CH}_2 - \text{NH}_2$ (determine the structures of nitro compound, nitrile, and amide that would produce this amine upon reduction)
- ii) For the secondary amine: $\text{CH}_3 - \text{CH}_2 - \text{CH}_2 - \text{CH}_2 - \text{NH} - \text{CH}_3$

24.3 REACTIONS OF AMINES

24.3.1 Basicity of Amines

The amines which are soluble in water form weakly alkaline solutions, just as ammonia does due to partial reaction with solvent forming OH^- ions.



The basicity of amines depends on the availability of the “lone pair” of electrons on the nitrogen atom. Reactions of different amines and ammonia with water show their $\text{p}K_b$ values. The Larger the K_b (or smaller the $\text{p}K_b$), the stronger is the base. It is clear that electron-donating alkyl groups attached to the nitrogen atom increase the basicity of amines, whereas the electron-withdrawing groups decrease it. Basicity is also an indicator of the stronger nucleophilic character of a compound, mostly. Following this, we can infer that:



- Ethanamine is a stronger base than ammonia and methanamine (primary amine). Likewise, alkyl amines are stronger base than ammonia as well.
- Ammonia is a stronger base than aromatic amines like phenyl-amine. This is because in phenylamine, the lone pair of electrons on the nitrogen atom is delocalized over the benzene ring as shown in **Figure 24.1**. The nitrogen atom is planar, with its lone pair in a p orbital. This can overlap with the delocalized π electrons of benzene ring.

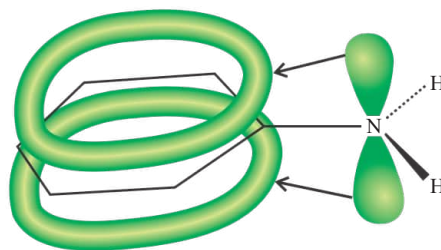

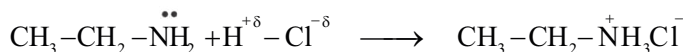
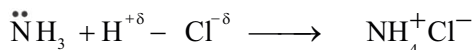


Figure 24.1 Delocalisation of the nitrogen lone pair in phenylamine

Table 24.1 The basicity of some amines

Sr.No.	Amine	Formula	K _b	pK _b
1	Ammonia	NH ₃	1.8 × 10 ⁻⁵	4.75
2	Ethanamine	CH ₃ -CH ₂ -NH ₂	5.1 × 10 ⁻⁴	3.29
3	Phenylamine (Aniline)	 -NH ₂	4.2 × 10 ⁻¹⁰	9.38

Ammonia and ethanamine react with an acid to form salts due to their basic nature. In this reaction, the nitrogen atom donates an electron pair to form a dative bond with a proton, forming a salt.



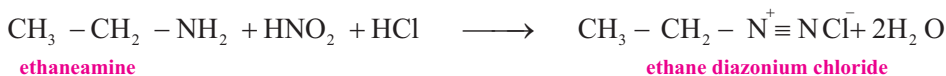
Did You Know?

The foul smell from fish is due to N,N- dimethylmethanamine (trimethylamine). When lemon juice is sprinkled on fish its acid (citric acid) reacts with the amine making it less smelly. The same happens when the fish is processed with vinegar.

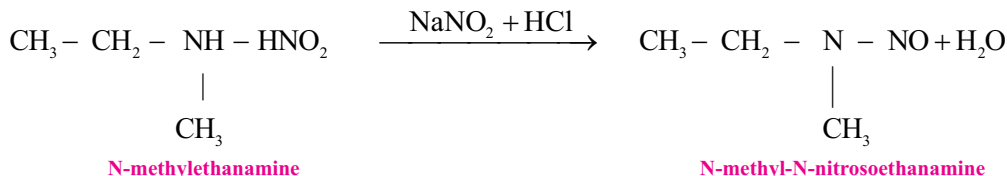


24.3.2 Distinction between primary and secondary amines

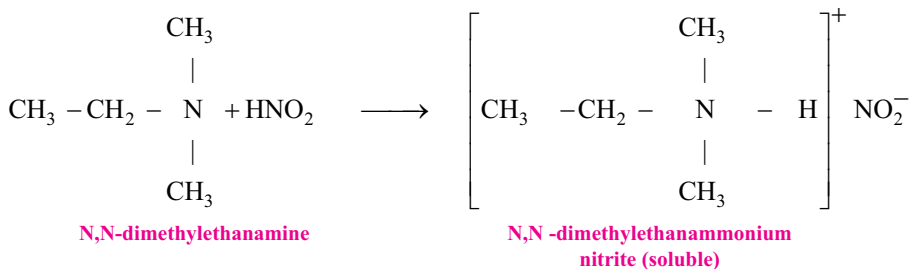
Primary, secondary and tertiary aliphatic amines are identified and distinguished by reacting them with nitric (III) acid (nitrous acid). Primary amines react with nitrous acid to form diazonium salts. The process is called diazotization.



Secondary amines form N-nitrosoamines (yellow oily liquid) on reaction with nitrous acid.)



Tertiary amines react with nitrous acid to form soluble salt.



The summary of the above reaction is

- Primary amines react with nitrous acid to produce nitrogen gas (seen as bubbles).
- Secondary amines react with nitrous acid to produce yellow oily liquid.

Tertiary amines react with nitrous acid to form soluble nitrite salts. There is no visible sign of reaction.



Quick Check 24.3



- Phenylamine is about a million times less basic than cyclohexylamine. Give reason.
- Which of ethanamine and propan-2-amine is more basic? Explain.
- Show the reaction of propan-2-amine with HCl. Name the salt formed.
- Which acid reacts with N,N-dimethylamine in fish when it is treated with vinegar? Write a chemical equation to show this reaction.



phenylamine
 $K_b = 4.2 \times 10^{-10}$

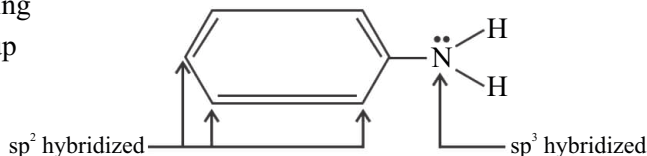


cyclohexylamine
 $K_b = 3.3 \times 10^{-4}$

24.3.3 Reactions of Phenylamine (Aromatic Amine)

Phenylamine gives two types of reactions:

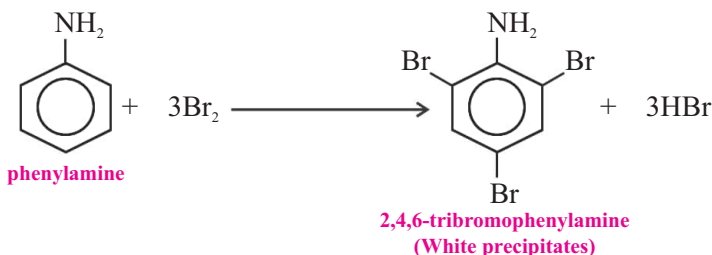
- due to benzene ring
- due to $-\text{NH}_2$ group



a) Reaction with bromine water

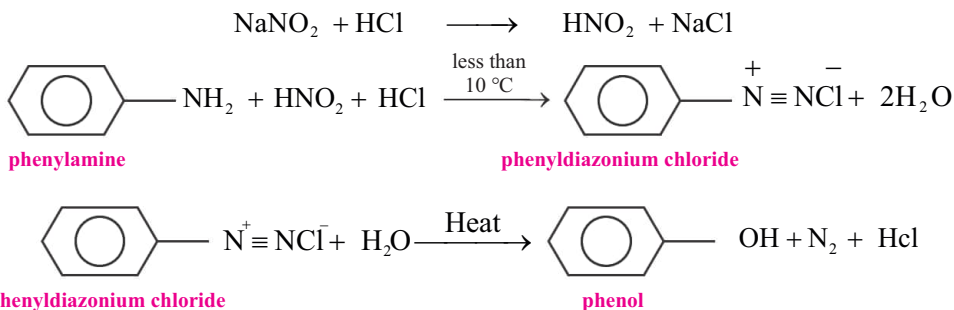
The amino group ($-\ddot{\text{N}}\text{H}_2$) is an ortho-para directing group. Therefore, the incoming electrophile attacks at “o” and “p” positions. The presence of the amino group makes benzene ring fairly reactive, especially at these position. Hence, bromination of phenylamine is faster than benzene, and its two ortho and the para positions, all are occupied in a single reaction.



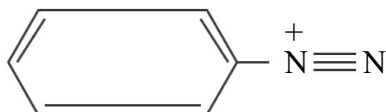


b) Reaction with Nitrous Acid and Formation of Azo Compounds

Phenylamine being a primary amine reacts with nitrous acid to form phenyldiazonium salt. This reaction is called diazotization. The organic compounds having diazonium ion, $-\text{N}^+\equiv\text{N}$ (diazo group) as a functional group are called diazo compounds. Both aliphatic and aromatic primary amines react with nitrous acid to yield diazonium salts. Nitrous acid is unstable and is prepared *in situ* by the reaction of sodium nitrite and HCl. The reaction mixture is kept below 10°C using ice. This is because the diazonium salts are unstable and will decompose easily, giving off nitrogen gas, N_2 , even at room temperature.



The alkyl diazonium salts are highly unstable under all conditions and therefore cannot be isolated. The aryl diazonium salts are however fairly stable at low temperatures. The extra stability of aromatic diazo compounds compared to aliphatic diazo compounds is due to the delocalization of the positive charge over the aromatic ring. Benzene diazonium salts are the important intermediates in the synthesis of many organic compounds.

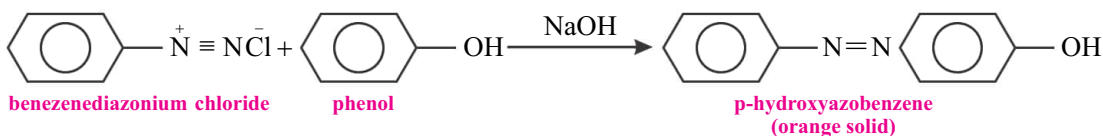


Coupling reactions of diazonium compounds

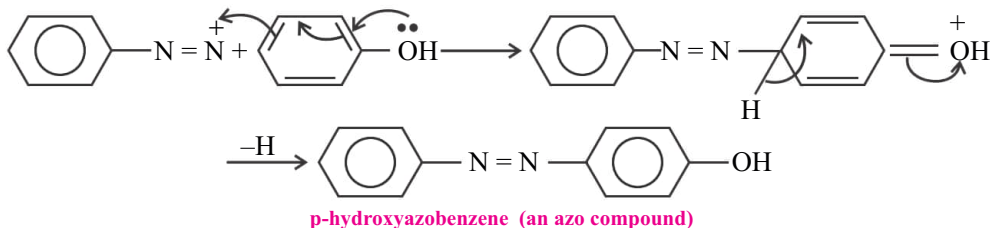
The reactions of aryl diazonium salts with strongly activated aromatic compounds, such as phenols and amines, are called coupling reactions. The products of such reactions containing a $-\text{N}=\text{N}-$ bond are called azo compounds. In the coupling reaction, the positively charged diazonium ion acts as an electrophile. It substitutes into the benzene ring of phenol at the para position.

Coupling with phenol occurs in mild alkaline solution and with aromatic amines in mild acidic conditions.



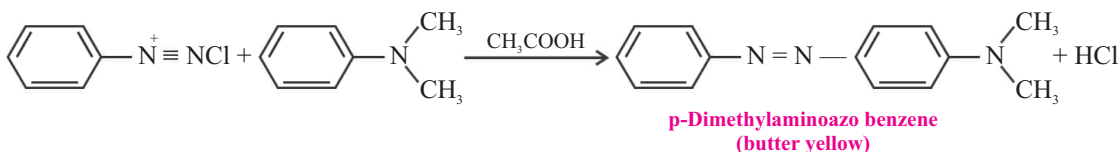


Mechanism

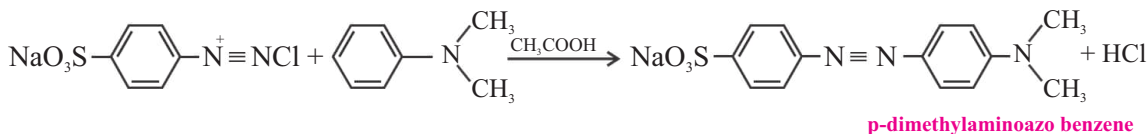


Formation of Dyes

Coupling reaction can be used to form different types of azo dyes. p-Dimethylaminoazo benzene is called Butter yellow, which was previously used in food. However, due to its carcinogenic nature, its use in food is now forbidden.



Methyl orange is an acid-base indicator and is prepared from diazotized sulfanilic acid and N, N-dimethylphenylamine as follows.



The azo group (Ph-N=N-Ph) in azo dyes is called a chromophore. This group is responsible for the intense colour of the dyes ranging from yellow and orange to red, blue and green depending upon what other groups are attached to the benzene rings.



Different food colours often contain azo dyes



Quick Check 24.4



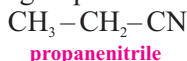
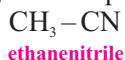
Azo dyes are the coloured compounds which are prepared by the reaction of diazonium salt of phenylamine and some aryl compound having activated benzene ring.

- How will you prepare a dye from phenylamine and 2-methylphenol.
- Give equations stepwise along with reaction conditions.



24.4 Alkanenitriles

The organic compounds containing -CN functional group are called alkanenitriles. For example

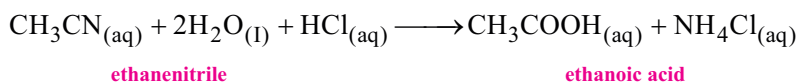


Preparation of alkanenitriles has been given in chapter 21.

Alkanenitriles are important compounds in many chemical reactions. However, the most important applications of alkanenitriles is their hydrolysis to produce carboxylic acids through hydrolysis. Hydrolysis of nitriles can occur with both dilute acid and dilute alkali.

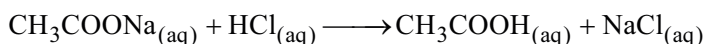
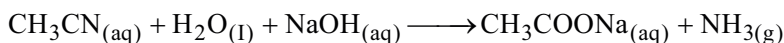
Acid hydrolysis of nitriles

When a nitrile is heated with a dilute acid, such as dilute hydrochloric acid or dilute sulphuric acid, a carboxylic acid is formed.



Alkaline hydrolysis of nitriles

When a nitrile is heated with a dilute sodium hydroxide solution, a salt of carboxylic acid is produced, which on acidification with dilute hydrochloric acid gives free carboxylic acid.



24.5 AMIDES

Amides contain the functional group $\text{—}\overset{\text{O}}{\parallel}{\text{C}}\text{—NH}_2$. Since they are prepared from carboxylic acids that is why amides are still sometimes called as “acid amides”.

Amides can be prepared by the following methods.

1. By the reaction of acyl chlorides with ammonia



benzoyl chloride

benzamide

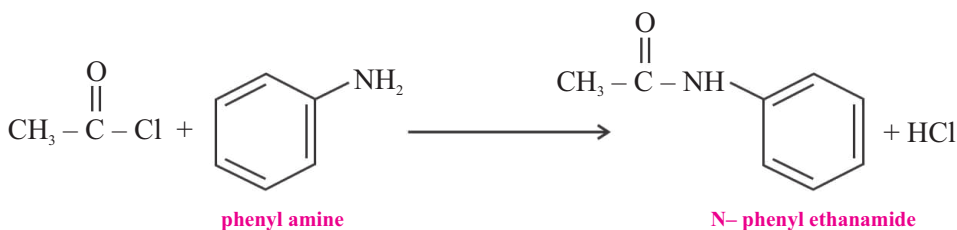
2. By the reaction of acyl chlorides with primary amines



ethanoyl chloride

N-ethyl ethanamide





In the above two methods, all the reactions take place at room temperature, releasing white fumes of hydrogen chloride (HCl). The HCl produced reacts with another molecule of ammonia or amine to form a salt.



All amides except methanamide, which is a liquid, are solid with sharp melting point. They have quite high boiling points which is a consequence of strong intermolecular hydrogen bonding. However, in case of N-substituted amides, the melting and boiling points decrease as the sites for hydrogen bonding diminish with increasing number of alkyl substituents.

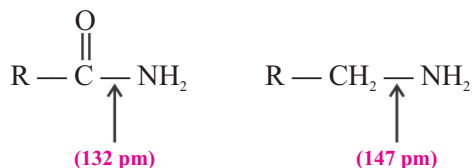
Therefore, an excess of ammonia or amine is used to ensure complete reaction.

Basic Properties of Amides

Amides are less basic than aliphatic amines. Unlike amines, amides form neutral solutions in water. They exhibit resonance where the lone pair on nitrogen participates in delocalization with oxygen of carbonyl group. This reduces the availability of electrons on nitrogen, thereby decreasing the basicity.



The introduction of double bond character between carbon and nitrogen reduces the C—N bond length less than the usual C—N single bond length.



Reactions of Amides

Amides are the least reactive of all acid derivatives, because lone pair of nitrogen is delocalized over the oxygen of carbonyl group, thus decreasing the electrophilic power (+δ charge) of the carbonyl carbon.

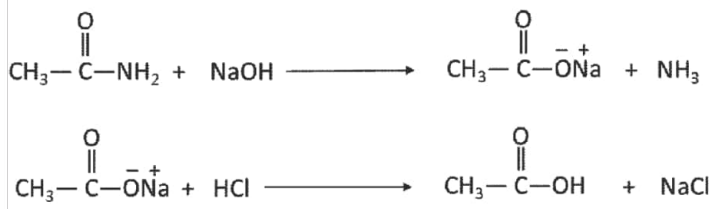
Reactions of amides are generally slow and require prolonged heating or catalysts (acid or base) for them to take place. Some of them are given as under:

1. Hydrolysis

Unsubstituted amides yield carboxylic acids ammonium salt.

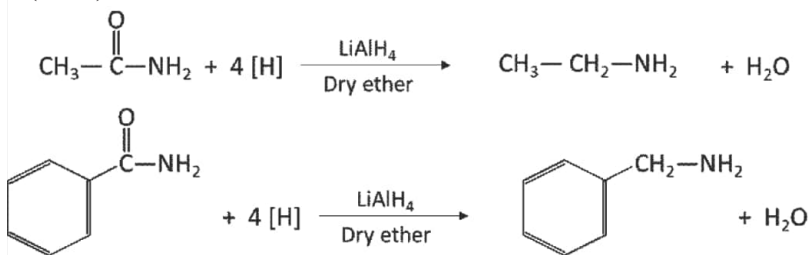


In the base-catalyzed reaction, the products are the salts of carboxylic acids and ammonia. The free carboxylic acid is obtained when this salt is treated with dilute hydrochloric acid.



2. Reduction

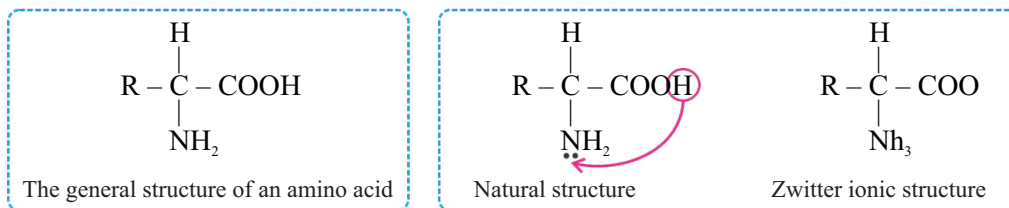
Amides are reduced to primary amines with lithium tetrahydridoaluminate (III) in dry ethoxyethane (ether).



24.6 AMINO ACIDS

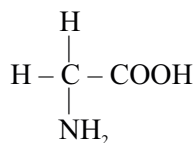
Amino acids are an important group of compounds that contain:
the basic amino group (-NH₂), and
the acidic carboxylic acid group (-COOH).

This makes amino acids amphoteric, as they can behave as both an acid and a base. The general structure of amino acids (2-aminocarboxylic acid), also called α -amino acids, is shown as.

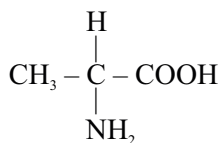


An α -amino acid exists as a dipolar ion called Zwitter ion, having a positive and a negative end within the same molecule. In the formation of a Zwitter ion, the proton goes from the carboxyl group to the amino group. The dipolar structure is also called the internal salt.

The R group is the part of the amino acid that can vary in different amino acids. The simplest amino acid is glycine (aminoethanoic acid) in which R is a hydrogen atom. Alanine (2-amino propanoic acid) is an amino acid in which the R group is the methyl group, -CH₃.



glycine



alanine

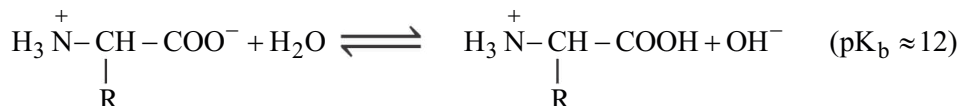
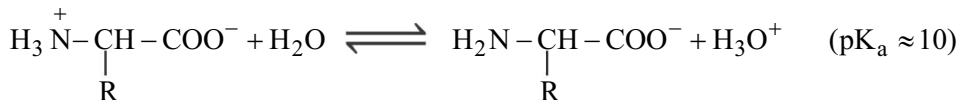
Except glycine all α -amino acids are chiral.

Out of 20 α -amino acids, 10 are essential (body cannot synthesis) and 10 are non-essential (body can synthesis) amino acids.

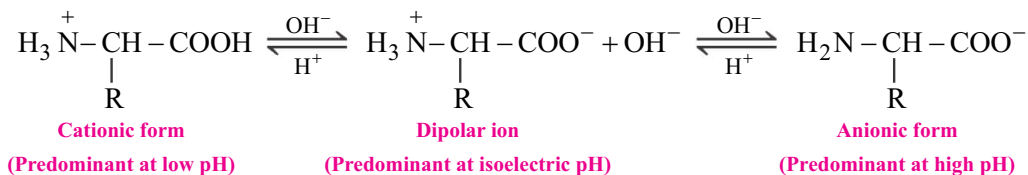


24.6.1 Acidic and Basic Properties of Amino Acids

Amino acids are amphoteric, i.e., they show both acidic and basic properties. However, they are less acidic than most carboxylic acids, and are less basic than most amines. In fact, the acidic part of the amino acid molecule is $-\text{NH}_3^+$ group, not $-\text{COO}^-$ group, and the basic part is $-\text{COO}^-$ group, not $-\text{NH}_2$ group. RNH_3^+ is a weaker acid than RCOOH , as shown below:



In the aqueous solution, an equilibrium exists between the dipolar ion and a cationic and an anionic form of an amino acid.



For each amino acid, there is specific pH at which the concentration of the zwitter ion reaches its maximum value. This pH is called the isoelectric point (pI), and each amino acid has its own unique pI.

24.6.2 Separation of Amino Acids via Electrophoresis

Amino acids can be separated from each other by a variety of techniques. One method, called electrophoresis, is used to separate amino acid in a mixture based on their charge. In this technique, a few drops of the mixture are applied to a filter paper or gel that is placed in a buffered solution between two electrodes. When an electric field is applied, the amino acids separate based on their different pI values. If the pI of an amino acid is greater than the pH of the solution, the amino acid will exist predominantly in a form that bears a positive charge and will migrate toward the cathode. The greater the difference between pI and pH, the faster it will migrate. An amino acid with a pI that is lower than the pH of the solution exists predominantly in a form that bears a negative charge and will migrate toward the anode. The greater the difference between pI and pH, the faster it will migrate (**Figure 24.2**). If two amino acids have very similar pI values (such as glycine and leucine), the amino acid with the larger molecular weight will move more slowly, because the charge has to carry a greater mass.

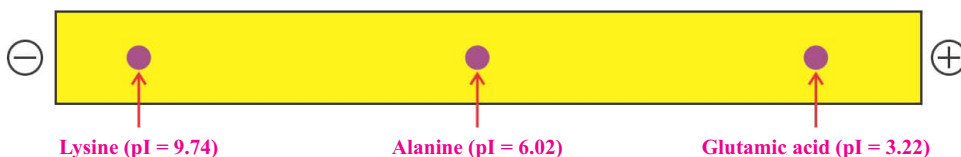
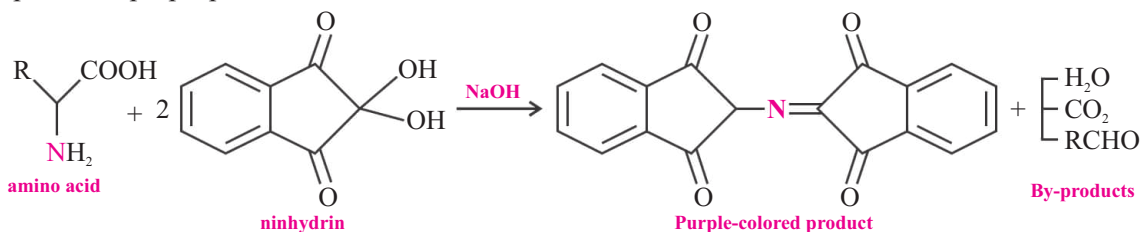


Figure 24.2 Separations of amino acids at pH 6 by electrophoresis



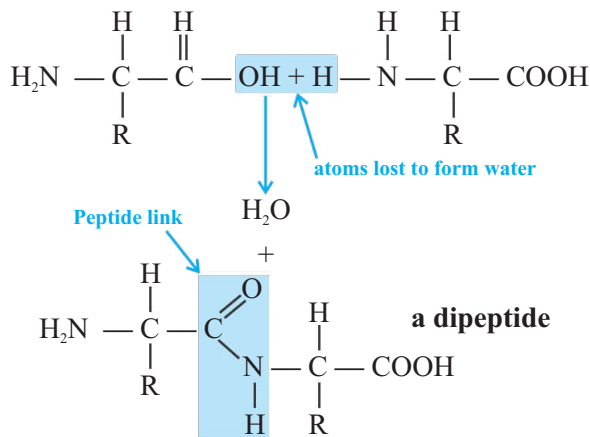
Amino acids are colorless, so a detection technique is necessary in order to visualize the location of the various spots. Ninhydrin is used as a locating agent, which reacts with amino acids to produce a purple product.



Electrophoresis cannot be used to separate large quantities of amino acids. It is used just as an analytical method for determining the number of amino acids in a mixture. In order to actually separate an entire mixture of amino acids, other laboratory techniques are used, such as column chromatography.

24.6.3 Peptides

Amino acid molecules can also react with each other. The acidic -COOH group in one amino acid molecule reacts with the basic -NH_2 group in another molecule. When two amino acids react together, the resulting molecule is called a dipeptide.



isoelectric point: the pH value at which there is no overall charge on a particular amino acid in its aqueous solution.

tripeptide: a compound formed from the condensation reaction between three amino acids.

polypeptide: a compound formed from the condensation between a large number of amino acids.

Note that the shaded area is the amide bond between the two amino acids. An amide bond between two amino acid molecules is also called a peptide bond or peptide link. The reaction is a condensation reaction, as a small molecule, in this case water is eliminated when the reactant molecules join together.



Quick Check 24.5



The R groups in the amino acids aspartic acid and lysine are $(-\text{CH}_2-\text{COOH})$ and $(-\text{CH}_2-(\text{CH}_2)_3\text{NH}_2)$ respectively.

- Draw the displayed formulae of these amino acid.
- Draw the structures of their Zwitter ions.
- Draw the structures of their ions in acidic conditions.
- Draw the structures of their ions in basic conditions.

Discuss with what we mean by the isoelectric point of these amino acids.



Exercise

Q1. Multiple Choice Questions:

I. Primary, secondary and tertiary amine are regarded as:

- | | |
|-----------------------------|---------------------|
| a) Tautomers | b) Metamers |
| c) Functional group isomers | d) Position isomers |

II. General formula for secondary amines is:

- | | |
|-------------------------|---------------------|
| a) RNH_2 | b) RNHR |
| c) R_3N | d) RCONH_2 |

III. Which one of the following bases is a strongest one?

- | | |
|-----------------|------------------|
| a) Ammonia | b) Ethyl amine |
| c) Phenyl amine | d) Diethyl amine |

IV. Acid hydrolysis of nitriles produces:

- | | |
|--------------------|-----------|
| a) Alcohol | b) Ketone |
| c) Carboxylic acid | d) Ester |

V. Phenyl amine reacts with aqueous Br_2 to form:

- | | |
|--------------------|------------------------------|
| a) Phenol | b) 2,4,6-Tribromophenylamine |
| c) An azo compound | d) None of these |

VI. Benzenediazonium chloride reacts with phenol in NaOH to form:

- | | |
|---------------------|-------------------|
| a) Phenyl hydrozine | b) Nitro compound |
| c) Azo compound | d) Alcohol |

VII. What is the structure of an azo compound:

- | | |
|--------------------------------|-------------------------------|
| a) $\text{R}_1\text{-N=N-R}_2$ | b) $\text{R}_1\text{-NH-R}_2$ |
| c) R-O-R | d) $\text{R-C}\equiv\text{N}$ |

VIII. When diazonium salt is heated with water, the gas evolved is:

- | | |
|-----------------|---------------------|
| a) Nitrogen | b) Ammonia |
| c) Nitric oxide | d) Nitrogen dioxide |

IX. An aqueous solution of glycine is neutral because of the formation of:

- | | |
|---------------|-----------------|
| a) Carbanion | b) Carbocation |
| c) Zwitterion | d) Free radical |

X. Which amines are produced by the reduction of amides?

- | | |
|-------------|------------------|
| a) Primary | b) Secondary |
| c) Tertiary | d) None of these |

Q2. SHORT ANSWER QUESTIONS:

- Give two preparations of phenyl amine
- Give two preparations of secondary amines.



25

ORGANIC SYNTHESIS

Student Learning Outcomes

[C-12-D-109 to C-12-D-115]

- ⦿ Explain the concept of organic synthesis and functional group interconversions.
- ⦿ Identify organic functional groups using the reactions in this progression grid.
- ⦿ Predict properties and reactions of organic molecules based on functional group presence.
- ⦿ Devise multi-step synthetic routes for preparing organic molecules.
- ⦿ Analyze a given synthetic route in terms of type of reaction and reagents used for each step of it, and possible by-products.
- ⦿ Explain the concept of retro-synthesis and its application in organic synthesis.
- ⦿ Describe the use of artificial intelligence tools in designing organic molecules which may have the potential to be used as medicine (Halicin can be used as an example).

INTRODUCTION

The study of organic chemistry is organized around functional groups. Although millions of organic compounds are known, there are only a handful of functional groups and each one serves to define a family of organic compounds. Functional group is a part of organic compound where most of the reactions occur. In organic synthesis we design different possible ways to build a target molecule from simpler easily available components. Functional groups play a central role in designing a synthesis. They enable chemists to predict and control the reactions which ultimately lead to the desired product. Identifying a functional group present in a compound can help to predict the properties of the compound. This information is crucial for the development of new organic products, as well as to ensure the purity and composition of the products such as medicines and food additives.

25.1 SYNTHESIS AND RETROSYNTHESIS

Before we start preparing an organic compound, it is important to understand the chemical reactions, the reagents, and the conditions required to complete each step to guarantee successful formation of the target molecule.

Most organic compounds can be prepared by a number of different routes and criteria is required to select the best route. A good synthesis of a substance involves the conversion of cheap and easily available starting materials to the desired product adopting a route which involves the least number of steps and gives a high overall yield.

A large variety of organic reactions that can be used in organic synthesis are known. They can be categorized as whether they bring about functional group interconversions (FGI) or a carbon-



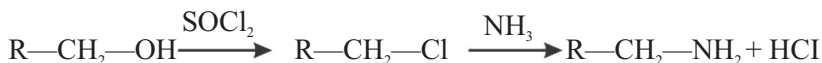
carbon bond formation. Carbon-carbon bond formation reactions are particularly important because the basic strategy of synthesis is to assemble the target molecule from simple and smaller starting materials.

25.1.1 Synthesis

In synthesis, the target molecule is prepared starting from simple commercially available compounds. It may involve many steps or transformations to reach the final target molecule. For example, primary aliphatic amine can be prepared in a single step by treating a haloalkane with ammonia.



Since haloalkane is not easily available rather it is prepared from an alcohol which is more easily available as a starting material. The synthesis of an alkyl amine may be completed in two steps.



25.1.2 Retrosynthesis

It is exactly the opposite of the synthesis. It involves the breaking down of the target molecule into less complicated, simpler and more readily available compounds which can serve as starting material. Retrosynthesis involves the disconnection approach.

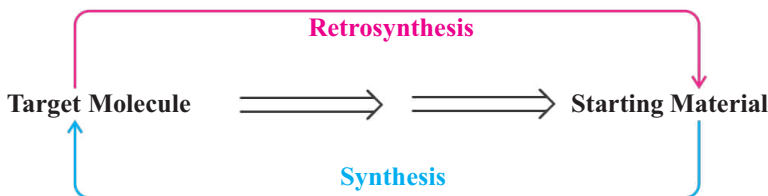


Figure 25.1. Synthesis and retrosynthesis routes

In retrosynthesis, those bonds of the target molecule are disconnected that result in a considerable structural simplification. Following a series of disconnections, we shall eventually arrive at simple, easily available starting materials.

Simple terminology used during retrosynthesis

- **Retrosynthetic arrow** is an open-ended arrow and denoted by \Rightarrow .
- **Target Molecule (TM)** is the molecule which is to be prepared by disconnection.
- **Disconnection** is a process which involves the imaginary breaking down of the TM progressively into simpler starting materials.
- **Synthons** are fragments of the target molecule which are generated by a disconnection. They are often an ionic species and represent the building blocks for the synthesis.
- **Synthetic Equivalent (SE)** is a reagent used to carry out the function of a synthon which cannot be used itself because it is usually unstable.
- **Functional Group Interconversion (FGI)** is the conversion of one functional group into another to reach the target molecule.



- Retrosynthetic Tree is a diagram showing all possible disconnections and synthons from the target molecule to starting materials.

Figure 25.2 shows all the terminologies in a single scheme.

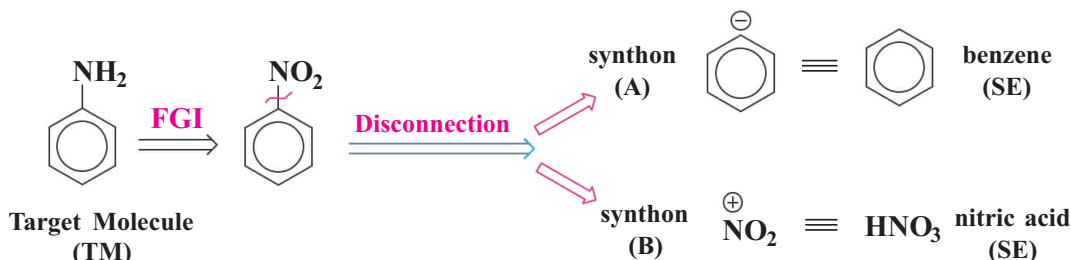


Figure 25.2. Terminologies used in retrosynthesis

Functional Group Interconversion

FGI is a phenomenon to change a functional group into another functional group, required for synthesis of a specific compound. FGI has a crucial role to play in designing routes which lead to target molecules. Simple starting materials can be converted to more complex target molecules using FGI as building blocks. FGI not only allows to create the carbon skeleton of the target molecule but also select the route to be adopted for this purpose.

The interconversions of functional groups have been studied in detail in earlier chapters and a summary of these interconversions is given in Figure 25.3 and 25.4.

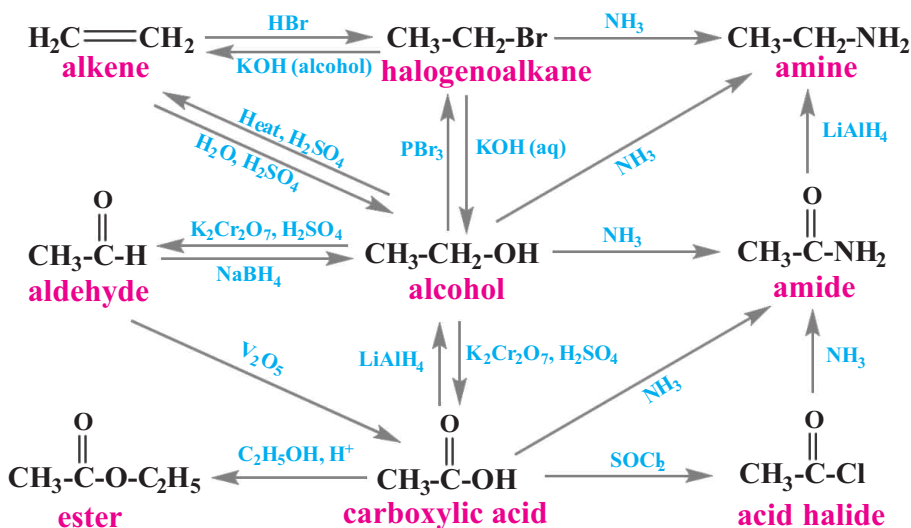


Figure 25.3. Functional group interconversion in aliphatic organic compounds



Quick Check 25.1



- Why aldehydes and ketones undergo nucleophilic addition reaction readily?
- Convert a carboxylic acid to its anhydride.



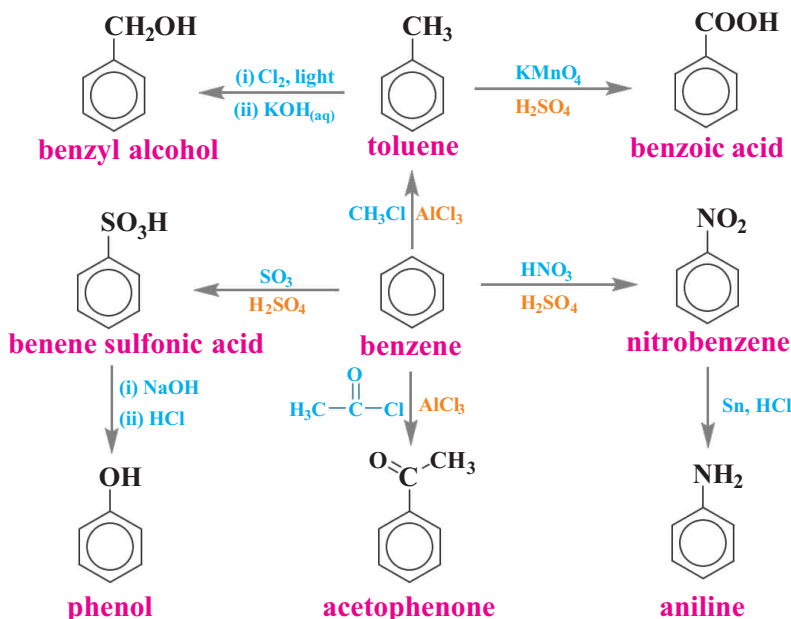


Figure 25.4. Functional group interconversion in aromatic organic compounds

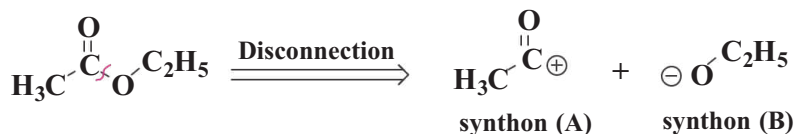
25.2 RETROSYNTHESIS AND SYNTHESIS OF SOME COMPOUNDS

Example 25.2.1 $\text{CH}_3\text{COOC}_2\text{H}_5$ (ethyl acetate, TM)

Retrosynthetic tree

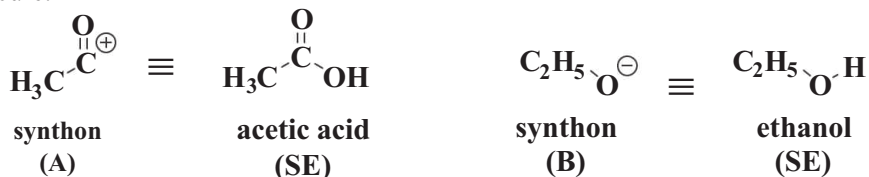
Step I Disconnection

Disconnection at the position indicated will enable us to get synthon A and synthon B whose synthetic equivalents are also shown. While selecting synthetic equivalent molecules thus obtained, they should undergo reaction to give the target molecule.



Step II Synthetic Equivalents (SE)

These synthons were neutralized to get synthetic equivalents i.e., acetic acid and nitric acid molecule.



For our target molecule ethyl acetate, the disconnection followed by neutralization yields acetic acid and ethanol as simpler starting materials to synthesize the TM.



Synthesis of TM (ethyl acetate)

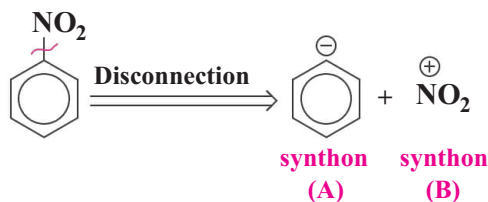
Here we can design the synthesis of our TM by a very familiar esterification reaction between acetic acid and ethanol to get ethyl acetate.

**Example 25.2.2** $\text{C}_6\text{H}_5\text{—NH}_2$ (aniline, TM)**Retrosynthetic tree****Step I Functional group interconversion**

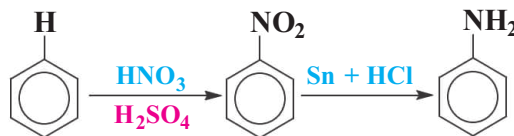
First step of retrosynthesis here is FGI, where amino group (NH_2) is converted into nitro (NO_2) group. Because it is easy to attach nitro group on benzene by electrophilic substitution, rather than amino group by nucleophilic substitution.

**Step II Disconnection**

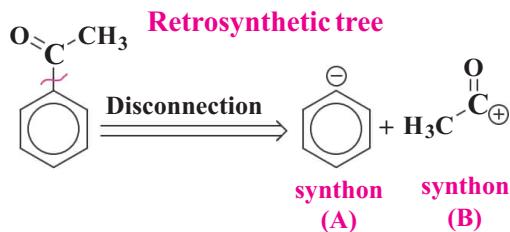
In second step the disconnection of nitrobenzene was done from C—N bond, which created synthons of aryl anion (C_6H_5^-) and nitronium (NO_2^+) cation.

**Step III Synthetic Equivalents (SE)**

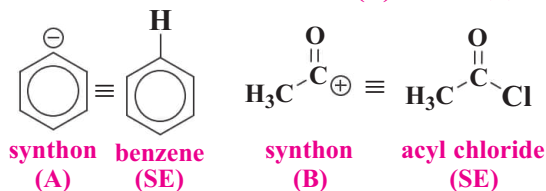
These synthons were neutralized to get synthetic equivalents i.e., benzene and nitric acid molecule.

**Example 25.2.3** $\text{C}_6\text{H}_5\text{COCH}_3$ (acetophenone, TM)**Step I Disconnection**

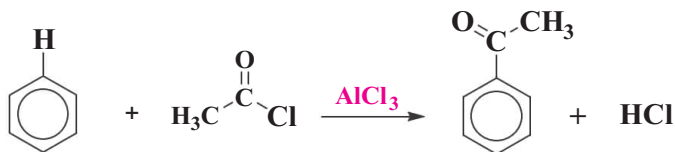
In first step the disconnection of acetophenone (TM) was done from C—C bond, which created synthons of aryl anion (C_6H_5^-) and acylium (CH_3CO^+) cation.

**Step II Synthetic Equivalents (SE)**

These synthons were neutralized to get synthetic equivalents i.e., benzene and acyl chloride molecule.

**Synthesis of TM (acetophenone)**

Synthesis of acetophenone can be done by reaction between benzene and acyl chloride, in the presence of AlCl_3 as catalyst, using Friedel-Craft acylation process.



MORE INFO

Interesting Information

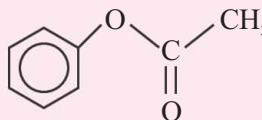
The landmark synthesis of cholesterol was first achieved in early 1950s by two competing groups headed each by Robert Robinson in Oxford and R.B. Woodward at Harvard. These synthetic schemes of cholesterol, had been previously predicted through biological studies.



Quick Check 25.2



- Why nitration of benzene is done during synthesis of aniline?
- Phenyl ethanoate is an important molecule used in synthesis of medicines for hepatitis and various infection.
 - Draw its retrosynthetic tree.
 - Write structures of its synthetic equivalents.
 - Design its linear synthesis.

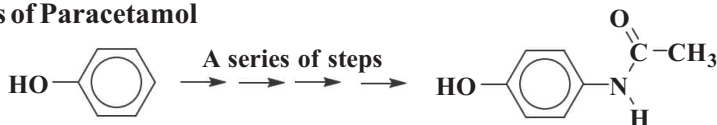


25.3 SYNTHESIS OF PHARMACEUTICAL PRODUCTS

One of the most important applications of retrosynthesis is in pharmaceutical product synthesis. There are hundreds of valuable medicinal compounds, which look very complex in their structure, but if they are disconnected properly and efficiently, we can approach to very simple and commonly available starting materials. This is the beauty of organic synthesis, that it makes the highly complex and terrifying structure, look so simple and achievable after a series of efficient retrosynthetic steps. In the following we will discuss synthesis of some common pharmaceutical products.

Example 25.3.1 Paracetamol (TM)

Direct Synthesis of Paracetamol

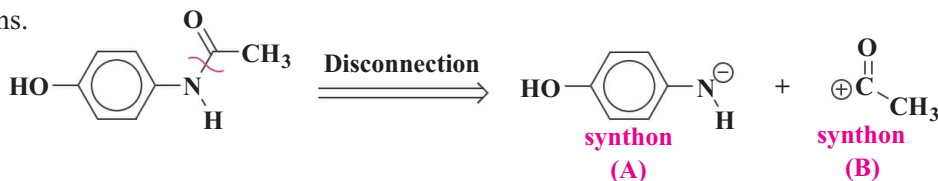


It can be seen that direct synthesis of paracetamol requires a series of steps. This series of steps can be decoded by its retrosynthesis as follows,

Retrosynthesis of Paracetamol

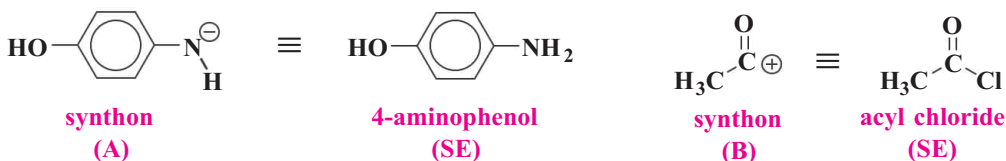
Step I Disconnection

The first step is the disconnection of paracetamol from C—N bond in amide group to get synthons.



Step II Synthetic Equivalents (SE)

These synthons were neutralized to get synthetic equivalents i.e., 4-aminophenol and acyl chloride molecule.



The bond is broken at the position indicated because the synthetic equivalents of the resulting synthons are well known to react through a nucleophilic addition-elimination reaction.

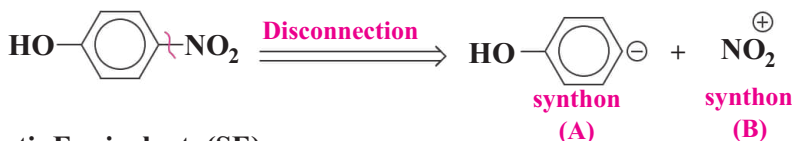
Step III Functional group interconversion

FGI has been done because it is easy to prepare p-nitrophenol and it can then be reduced to p-aminophenol.



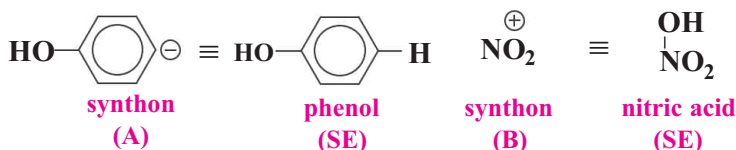
Step IV Disconnection

Then disconnection of 4-aminophenol was done from C—N bond, which created synthons of 4-hydroxy aryl anion (C_6H_5^-) and nitronium (NO_2^+) cation.



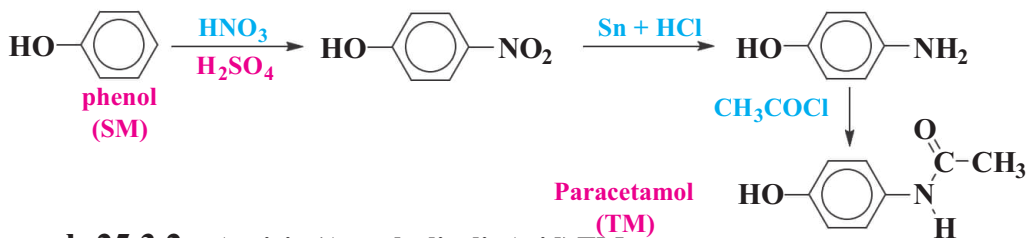
Step V Synthetic Equivalents (SE)

These synthons were neutralized to get synthetic equivalents i.e., benzene and nitric acid molecule.



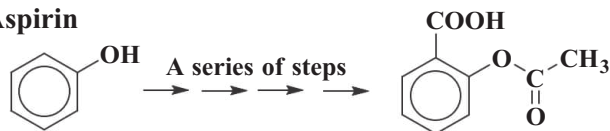
Synthesis of Paracetamol

Paracetamol will then be synthesized according to the following scheme.



Example 25.3.2 Aspirin (Acetylsalicylic Acid) TM

Direct Synthesis of Aspirin



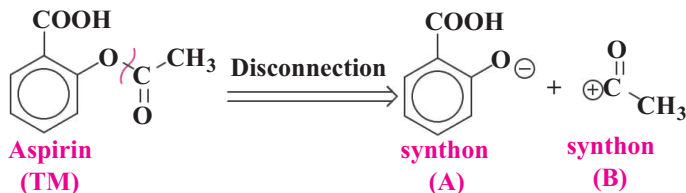
Just like Paracetamol the direct synthesis of Aspirin also requires a series of steps. By retrosynthesis we can truly find how many and which steps are actually needed to prepare Aspirin from phenol (simple starting material).

Retrosynthesis of Aspirin

Retrosynthetic Tree

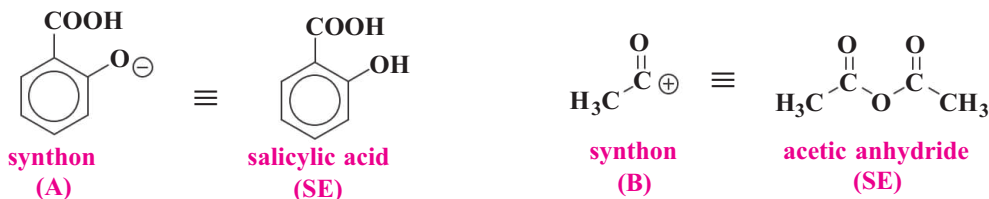
Step I Disconnection-I

The first step is the disconnection of Aspirin from C—O bond in ester linkage to get synthons.



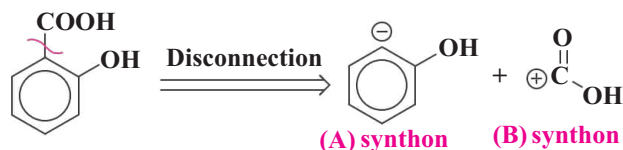
Step II Synthetic Equivalents (SE)

These synthons were neutralized to get synthetic equivalents i.e., salicylic acid and acetic anhydride molecule.



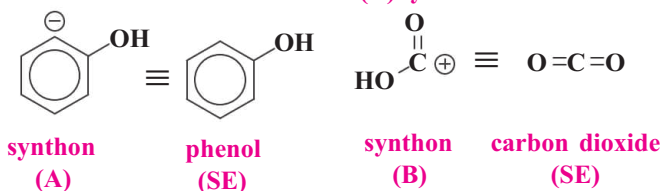
Step III Disconnection-II

Next disconnection is the C—C bond of carboxylic group.



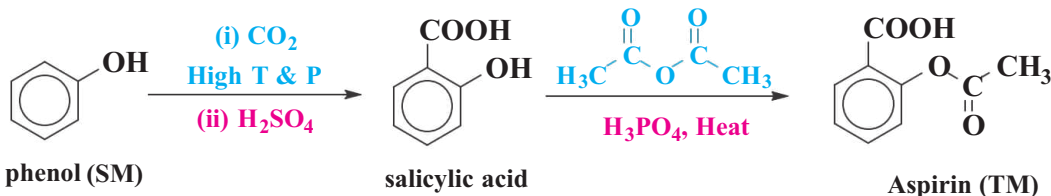
Step IV Synthetic Equivalents (SE)

These synthons were neutralized to get synthetic equivalents i.e., phenol and carbon dioxide molecule.



Synthesis of Aspirin

Aspirin will then be synthesized according to the following scheme.



Quick Check 25.3



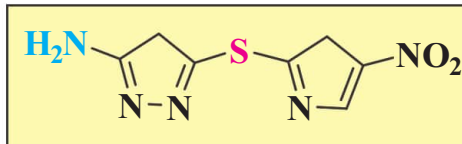
Aspirin and Paracetamol, both are synthesized starting from phenol.

- i) What is the overall functional group difference in them?
- ii) In synthesis of which FGI (Functional Group Interconversion) is involved?
- iii) Which synthon is common in preparation of them? Write down its structure and also mention its most common synthetic equivalent.



25.4 USE OF ARTIFICIAL INTELLIGENCE (AI) IN DRUG DESIGNING

The past few decades have seen the development of very few new antibiotics. Those which have been developed are only slightly different from the existing ones. The methods which are currently used to develop new drugs are very costly, time consuming and are usually limited to a narrow spectrum of chemical activity. We are also facing growing number of cases whereby the prevalent antibiotics become resistant to existing pathogens.



In order to find out a solution to this problem the researchers at MIT (Massachusetts Institute of Technology) designed a machine-learning algorithm to look for chemical features that make molecules effective at killing *E. coli* bacteria. To do so, they applied the model on 2500 molecules and a set of 800 natural products with different structures and a wide range of bioactivities. Once the computer model was applied to these compounds, it picked out one molecule that was predicted to have antibacterial properties with a molecular structure different from the existing antibiotics.

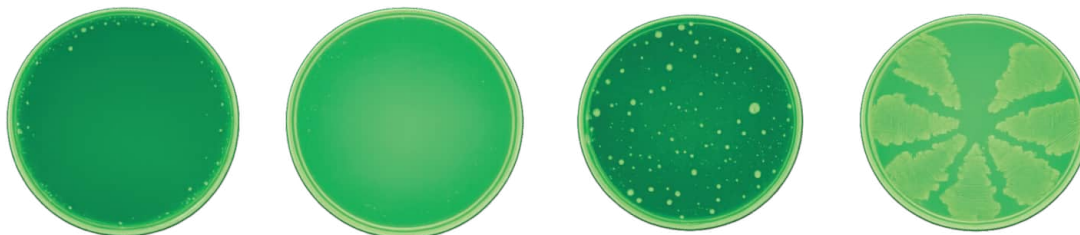


Figure 25.5. Anti bacterial activity of Halicin

Using a different model, the researchers also showed that this molecule would most likely show low toxicity to human cells. Later on, this molecule was named as Halicin and it was tested against a number of bacterial strains isolated from patients. It was found that the new molecule killed many of the world's most problematic disease-causing bacteria which were previously resistant to treatment.

After identifying Halicin, the researchers applied their computer model to screen more than 100 million molecules selected from a database. This screening was completed in only three days, and it selected 23 more such molecules which have different structures from existing antibiotics. Researchers further, found that eight of these molecules showed antibacterial activities and two were particularly powerful. This groundbreaking work points out an altogether different route to discover new organic molecules which may be used as drugs.

MORE INFO

Interesting Information

The historic total synthesis of vitamin B₁₂ was achieved by R.B. Woodward and A. Eschenmoser in 1972 after over 10 years of collaboration. The total synthesis involved over 100 steps and required 91 post-doctoral researchers and 12 PhD students.



Exercise

Q1. Multiple Choice Questions:

I) After disconnection the components obtained are called:

- a) target molecule
b) synthons
c) synthetic equivalents
d) starting material

II) How will you convert the amide functional group ($-\text{C}\equiv\text{N}$) to the amine group?

- a) by an oxidation reaction
b) by a reduction reaction
c) by an acid hydrolysis
d) by an addition reaction

III) What does this arrow (\rightleftharpoons) mean in organic chemistry reactions?

- a) synthesis
b) Retrosynthesis
c) reversible reaction
d) disconnection

IV) Which reagent you will choose to convert aldehyde group into alcohol?

- a) KMnO_4/H^+
b) $\text{NaBH}_4/\text{H}_3\text{O}^+$
c) Zn/HCl
d) $\text{Na}/\text{Liquid NH}_3$

V) Which reagent is commonly used to oxidize primary alcohol into carboxylic acid?

- a) $\text{H}_2, \text{Pd}/\text{C}$
b) LiAlH_4
c) $\text{K}_2\text{Cr}_2\text{O}_7, \text{H}_2\text{SO}_4$
d) NaBH_4

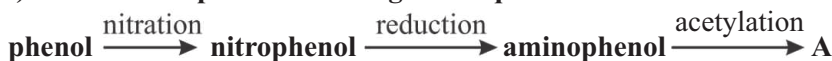
VI) When toluene is treated with $\text{KMnO}_4/\text{H}_2\text{SO}_4$, we obtain:

- a) benzyl chloride
b) benzene sulphonic acid
c) benzoic acid
d) acetophenone

VII) Which functional group is formed when a carboxylic acid reacts with an alcohol in the presence of an acid as catalyst?

- a) alkane
b) alcohol
c) aldehyde
d) ester

VIII) What is compound A in the given sequence?



- a) Aspirin
b) Paracetamol
c) Acetophenone
d) Halicin

IX) In organic synthesis, what is the primary purpose of a 'Functional Group Interconversion' (FGI)?

- a) To break the molecule into smaller fragments
b) To increase total number of carbon atoms in molecule
c) To make the molecule more reactive
d) To change the functional group into another to enable a specific reaction

X) The drug 'Halicin' developed by AI work as an:

- a) antiviral drug
b) antifungal drug



26

POLYMERS

Student Learning Outcomes

[C-12-D-98 to C-12-D-108]

- ⊙ Describe the chemical processes of addition and condensation polymerisation and the differences between them. Examples include.
 - Addition polymers such as poly(ethene) and poly(chloroethene), PVC.
 - Polyesters (from reaction of diol and dicarboxylic or dioyl acid and from hydroxylic acid).
 - Polyamides (from reactions of a diamine and a dicarboxylic acid or dioyl chloride of an amino-carboxylic acid or between amino acids).
- ⊙ Describe the condensation reaction of ammonia or an amine with acyl chloride at room temperature to give an amide.
- ⊙ Explain the chemical processes and properties of PVC and nylon and applications of these polymers in the industry.
- ⊙ Identify the polymer formed, the monomer present in a section of polymer, and classify them as one of the two polymers.
- ⊙ Deduce the repeating unit of a polymer obtained from a given monomer or pair of monomers and identify the monomers present in a given section of a polymer molecule.
- ⊙ Predict the type of polymerisation reaction for a given monomer or pair of monomers.
- ⊙ Recognize that polyesters and polyamide are biodegradable by acidic and alkaline hydrolysis.
- ⊙ Recognize that some polymers can be degraded by the action of light.
- ⊙ Recognize that poly(alkane) is chemically inert and can, therefore, be difficult to biodegrade.
- ⊙ Explain the challenges associated with the disposal of non-degradable polymers.
- ⊙ Outline the use of polymers to create artificial organs in biomedical science.

Polymers are very large molecules made by joining many small molecules called **monomers** through polymerisation.

Organic polymers are modern materials of great significance. They have made our lives easier, more efficient, and highly economical due to their superior properties and affordable costs. Polymers can be observed in our daily lives from shopping bags (poly(ethene)) and clothesline (poly(propene)) to plastic used in bulletproof vests (Kevlar[®]) and aerospace applications as in **Figure 26.1**. The properties of polymers broadly vary depending on the type and number of monomers in the polymer, and the



(a) (b)
Figure 26.1 a) A bulletproof vest made from Kevlar[®] b) poly(propene) rope



method through which they are manufactured. Some polymers are very light and soft, which are suitable for applications where soft materials are needed. Others are hard and thermally very stable allowing their utilization as hard and durable materials. In the above two examples, poly(ethene) and poly(propene) represent very light and soft kind, whereas Kevlar® is a hard material suitable for bulletproof vests.



Keep in Mind Systematic Names of Polymers

Synthetic polymers are named systematically by writing the prefix “poly” before the name of the monomer. For example, polythene is systematically named as poly(ethene) and polyvinylchloride is called poly(chloroethene). For polymers with two or more monomers, common names are usually used because the systematic name is too long. This is why poly(ethane-1, 2-diyl benzene-1,4-dicarboxylate) is commonly called polyethylene terephthalate, i.e. PETE.

26.1 POLYMERISATION

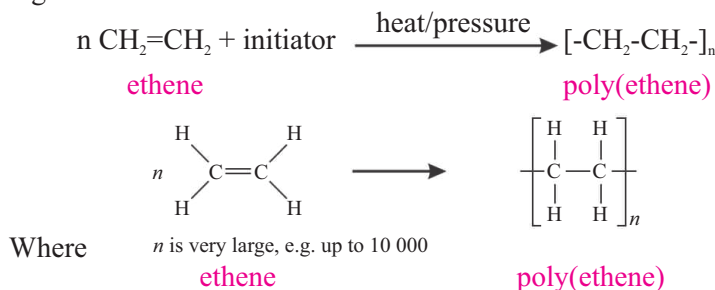
Polymerisation is the process of joining monomers to form a polymer. There are two main types of polymerisation:

- i) Addition
- ii) Condensation polymerisation.

26.1.1 Addition Polymerization

In addition polymerization, monomers add to each other one by one, forming long chains. All the atoms from the original monomers become part of the polymer. Nothing is lost. Monomers must have a carbon-carbon double (C=C) or triple bond (C≡C). This bond "opens up" to allow monomers to link together. No small molecules (like water) are produced as side products. This often happens through a "chain reaction" started by a very reactive molecule (an initiator, which forms free radicals).

Polyethene, a large number of ethene (CH₂=CH₂) molecules add together by breaking double bonds and linking end-to-end.



Poly(ethene) is primarily of two types:

- low density poly(ethene) (LDPE)
- high density poly(ethene) (HDPE)

Low density poly(ethene) is used where a very light and soft material is needed, such as shopping bags, light plastic bottles, etc. HDPE is produced from ethene using a catalyst called Zeigler-Natta catalyst at low pressure and temperature. It finds its uses in plastic containers, thick



shopping bags, toys, etc. LDPE and HDPE differ in the nature of their chains with LDPE being more branched. This makes it unable to pack tightly giving a less solid and more elastic material. While HDPE has linear chains allowing them to pack closely to give a compact structure with tough and dense material.

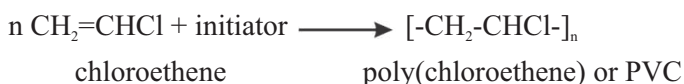


Did You Know?

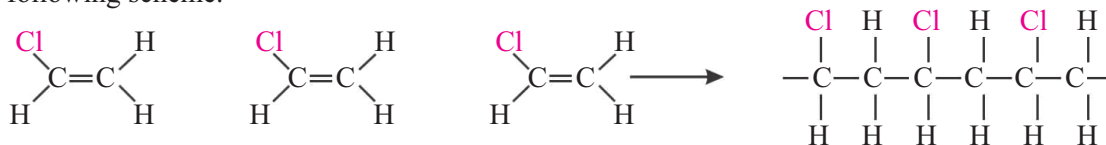
Ziegler-Natta catalysts are a Nobel Prize-winning invention that revolutionized plastic production. It was initially discovered by **Karl Ziegler** in 1953. This catalyst enabled, for the first time, the low-pressure polymerisation of ethene into linear, high-density poly(ethene) (HDPE). This same catalyst family was expanded by **Giulio Natta** to create stereoregular polymers, such as crystalline polypropylene.

Polyvinyl Chloride (PVC)

Poly(chloroethene) or PVC is made from a monomer called chloroethene ($\text{CH}_2=\text{CHCl}$) through an addition polymerisation reaction.



A more detailed depiction of the formation of PVC from its monomers is provided in the following scheme.



PVC is a versatile type of plastic. Its properties can be changed a lot by adding different chemicals (plasticizers). **Plasticizers are chemicals added to materials to make them softer, more flexible, and easier to work with.** They cause this by reducing the strong forces between polymer chains, allowing them to move more freely.

Rigid PVC (without plasticizers) is hard and stiff and doesn't bend easily. It is chemically inert because it does not react with most acids, bases, or oils. It is a good electrical insulator. Due to the chlorine atoms, it is naturally resistant to burning and self-extinguishing. It lasts a long time and resists weathering. Plasticised PVC (with plasticisers) is flexible and soft, so it can be bent and shaped easily. It maintains good chemical and electrical properties, but is less rigid.

Industrial Applications of PVC (Figure 26.2)

Various uses of PVC include:

- Pipes and fittings for water supply, drainage, and sewage systems due to its corrosion resistance and durability.
- Window frames and door profiles, floor vinyl tiles and sheets
- Electrical insulation for wires and cables.
- Tubing, blood bags, and catheters.
- Cling films, bottles (e.g., for cooking oil), blister packs.
- Raincoats, artificial leather, inflatable products (e.g., swimming pools).



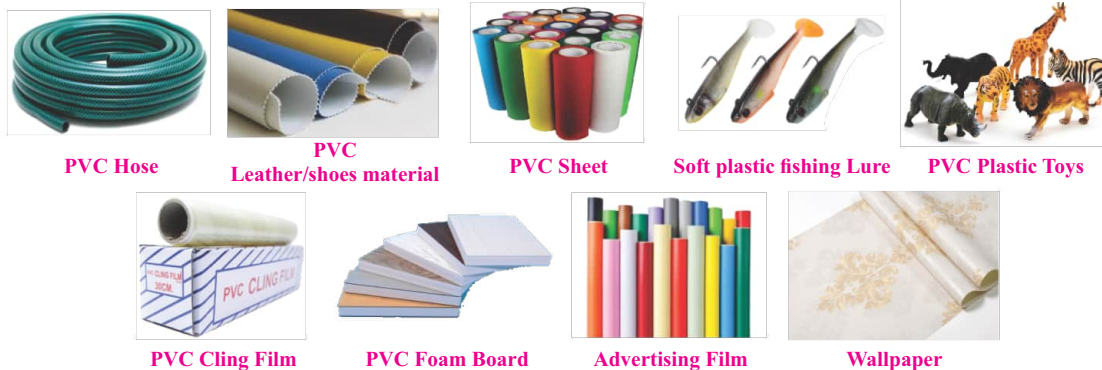


Figure 26.2 Various uses of PVC

26.1.2 Condensation Polymerisation

In condensation polymerisation, monomers join together, but each time a new bond forms, a small molecule is eliminated from the monomers. This small molecule is usually water can also be H_2O , HCl or CH_3OH , or NH_3 . Monomers must have at least two reactive functional groups (like $-\text{OH}$, $-\text{COOH}$, $-\text{NH}_2$) that can react with each other. These groups are on different ends of the monomer(s). Small molecules are always produced as a side product. This typically happens in a "step-by-step" manner as depicted in **Figure 26.3**.

Condensation polymerisation

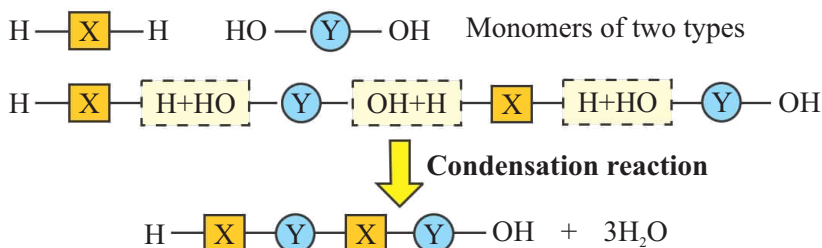
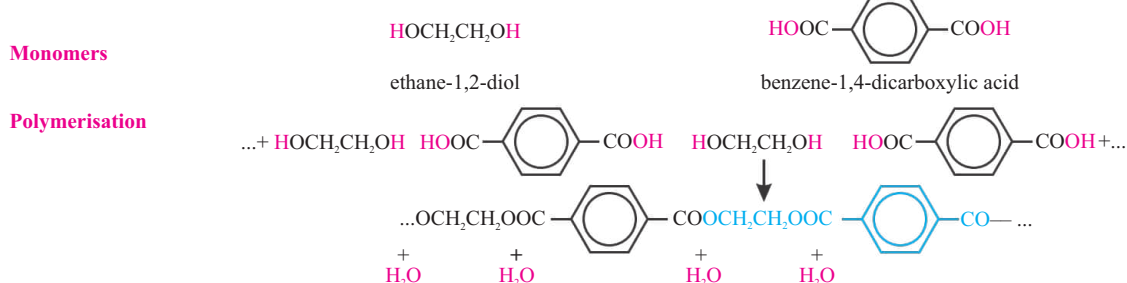


Figure 26.3 Illustration of condensation polymerisation

a) Polyesters

Polyesters have **ester links** $\left[-\overset{\text{O}}{\parallel}{\text{C}}-\text{O}- \right]$ in their backbone. A diol (molecule with two $-\text{OH}$ groups) and a dicarboxylic acid (molecule with two $-\text{COOH}$ groups) as monomers are combined to give polyester. The $-\text{OH}$ from the diol reacts with the $-\text{COOH}$ from the acid. A molecule of water is removed as shown below.



Preparation of Terylene/PET, a polyester from ethane-1,2-diol and Benzene-1,4-dicarboxylic acid.



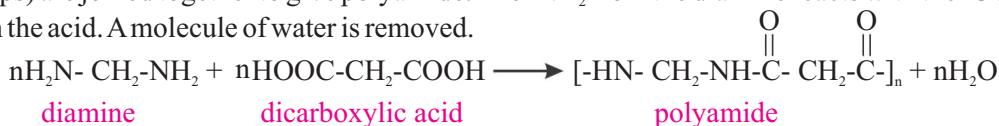
Polyesters have special features, such as high tensile strength, which make them suitable to manufacture fibres. Polyester is used as an alternative to cotton due to its low cost and ability to resist creases. It is also used as a plastic; for example, PETE is used in making plastic bottles for beverages and other food packaging. Polyester is also used as cross links to obtain hard plastics. An example is the glass fibre reinforced cross-linked polyester.

b) Polyamides

Polyamides have **amide links** $\left[-\overset{\text{O}}{\parallel}{\text{C}}-\text{NH}- \right]$ in their backbone. They can be prepared from many starting materials.

i) From a Diamine and a Dicarboxylic Acid:

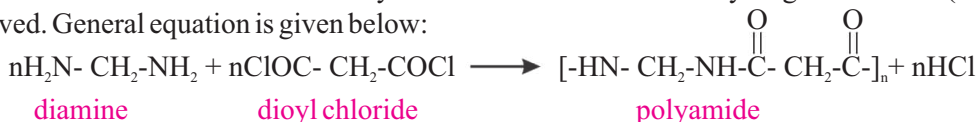
A diamine (molecule with two $-\text{NH}_2$ groups) and a dicarboxylic acid (molecule with two $-\text{COOH}$ groups) are joined together to give polyamide. The $-\text{NH}_2$ from the diamine reacts with the $-\text{COOH}$ from the acid. A molecule of water is removed.



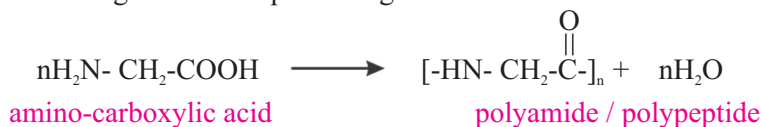
Example: Nylon 6,6 uses hexamethylenediamine and Adipic acid.

ii) From a Diamine and a Dioyl Chloride

A diamine and a dioyl chloride (molecule with two $-\text{COCl}$ groups) as monomers are joined to give polyamide. Dioyl chlorides are more reactive than dicarboxylic acids. The $-\text{NH}_2$ from the diamine reacts with the $-\text{COCl}$ from the dioyl chloride. A molecule of hydrogen chloride (HCl) is removed. General equation is given below:

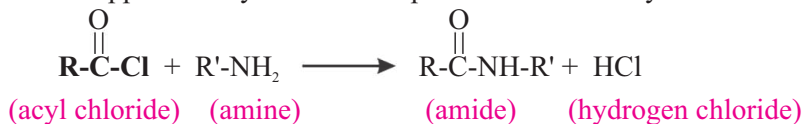


An amino acid is a single monomer that has both an $-\text{NH}_2$ (amino) group and a $-\text{COOH}$ (carboxylic acid) group in one molecule. The $-\text{NH}_2$ group of one amino acid reacts with the $-\text{COOH}$ group of another amino acid removing a water to form a peptide bond. Peptide bond is also a type of amide linkage. General equation is given below:



Proteins are natural polyamides made from amino acids, which will be discussed in Biochemistry (Chapter 27).

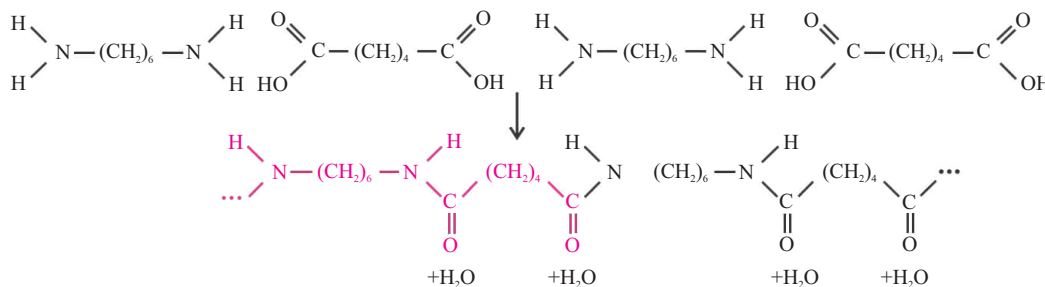
Amide linkage is also formed between acyl chlorides, a very reactive organic compound and an amine, e.g. ammonia, methanamine (CH_3-NH_2), N, N-dimethylamine, $(\text{CH}_3)_2\text{NH}$. When an acyl chloride reacts with ammonia or an amine, a molecule of hydrogen chloride (HCl) gas is removed. This reaction happens easily at room temperature because acyl chlorides are fairly reactive.



26.2 NYLON

Nylon is a type of synthetic polyamide. It is formed by condensation polymerisation, usually from two different monomers (a diamine and a dicarboxylic acid). During the reaction, a small molecule, typically water, is removed. Generally, a diamine ($\text{H}_2\text{N-R-NH}_2$) and a dicarboxylic acid (HOOC-R-COOH) act as monomers.

Nylon 6,6 is the most common example of synthetic amides. The formation of Nylon 6,6 involves a polymerisation reaction between 1,6-diaminohexane and 1,4-hexanedioic acid as shown below.

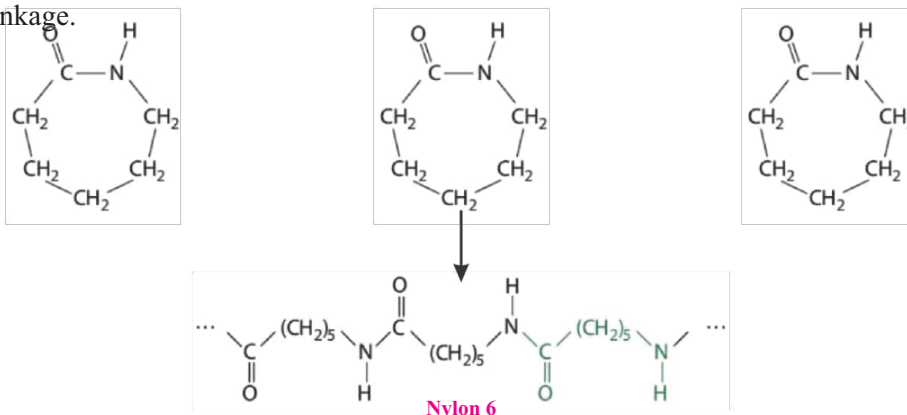


Preparation of nylon-6,6

The wheels of this skateboard are made from nylon, due to its hard, smooth, and shock-free nature.



Another type of nylon is nylon-6, which is formed from a single monomer called caprolactam as in the following scheme. It is named nylon-6 because it involves a monomer with six carbon atoms. Caprolactam has a cyclic structure as shown in the following figure. The reaction is not a typical condensation reaction because no small molecule is removed during the reaction. Nevertheless, nylon 6 is classified as a condensation polymer due to the mode of formation of the amide linkage.

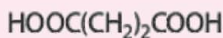
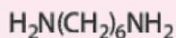
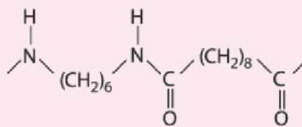


Nylon 6 is a harder material than nylon-6,6 and provides a smoother surface and higher impact resistance (harder to break by hitting). It is easier to mold as its melting point is lower than nylon-6,6. It is mostly used in rollers, skateboard wheels, and power tool handles to avoid shocks.




Quick Check 26.1


- a) The repeating unit of nylon-6, 10 is shown below. Draw the structures of its monomers from this structure.
- b) Monomers of nylon-6,4 are given below. Draw the structure of the repeating unit of the polymer formed from these monomers.



26.2.1 Properties of Nylon

- ✔ Strong and resistant to breaking and can withstand rubbing and wear and tear.
- ✔ Stretchable due to elasticity.
- ✔ Slippery surface, reduces friction.
- ✔ Generally resistant to oils, many solvents, and alkalis.
- ✔ High melting point.

26.2.2 Industrial Applications of Nylon

- ✔ It is used for clothing (stockings, activewear, and swimwear), carpets, and ropes due to its strength and elasticity. Its fabric is used for raincoats, sportswear, and lingerie.
- ✔ Nylon is used for the manufacturing of mechanical parts of automotive industry like gears, bearings, bushings, engine covers, and fuel lines due to its strength, low friction, and heat resistance.
- ✔ Nylon is also used in making of machine parts such as screws, nuts, bolts, and various industrial components where strength and wear resistance are needed.
- ✔ It is also commonly used to make ropes, fishing nets, and lines due to its high tensile strength and resistance to water wear.
- ✔ Consumer goods like zippers, toothbrushes, hairbrushes, and various molded plastic parts are made of nylon.

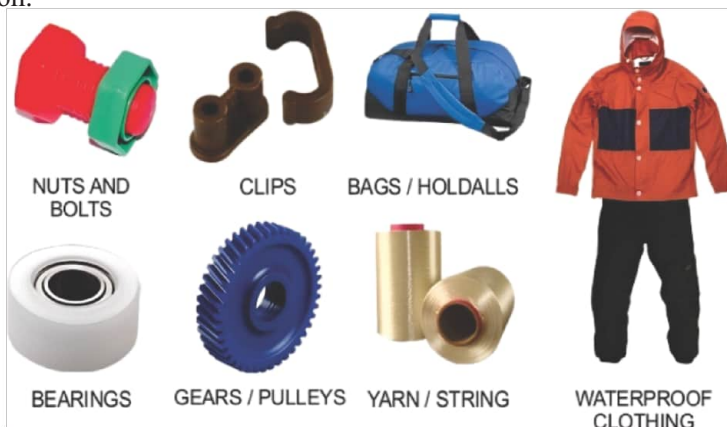


Figure 26.4 General uses of different types of nylon



26.3 IDENTIFICATION OF THE TYPE OF A POLYMER, REPEAT UNIT AND MONOMERS FROM A POLYMER SECTION

To identify a polymer from a skeletal or structural formula, you must look for the repeating linkage and the monomer units. At this level, only two classes of polymers are under discussion

i. Addition

ii. Condensation.

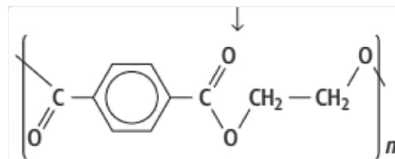
Follow the given steps to identify the type of the polymer by considering the example of poly(ethene)

1. Identifying the Type of Polymer:

- The first thing to check is what atoms make up the main horizontal chain of the polymer, i.e to identify the backbone. .
- If the main chain consists only of carbon atoms (-C-C-C-C-), it is an addition polymer. These are formed from alkenes.
- If the main chain contains oxygen (O) or nitrogen (N) atoms with carbon, it is a condensation polymer (like polyesters or polyamides).

Now, identify the functional linkage. There are again two possibilities:

- If a carbonyl group (C=O) is directly attached next to an oxygen (O). Such polymers are classified as polyesters. For example, PET has an ester linkage in the given section of its structure.



If there is a carbonyl group (C=O) directly next to a nitrogen (N) with a hydrogen (H) attached, it presents an amide or peptide linkage. The polymer is, therefore, classified as a polyamide (e.g., Nylon 6,6 or Kevlar).

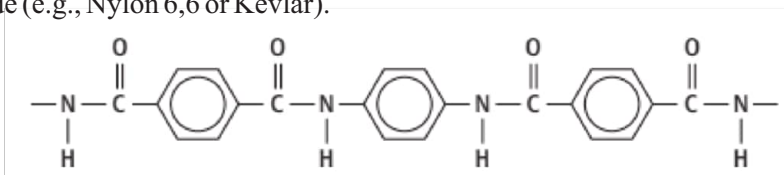


Table 26.1 Identification of the type of a polymer from its section

Functional Groups in the Polymer	Type	Example
Only C-C bonds in the chain	Addition Polymer	Poly(ethene), PVC, PTFE (poly(tetrafluoroethen))
-COO- links	Polyester	Terylene, PLA (poly(lactic acid))



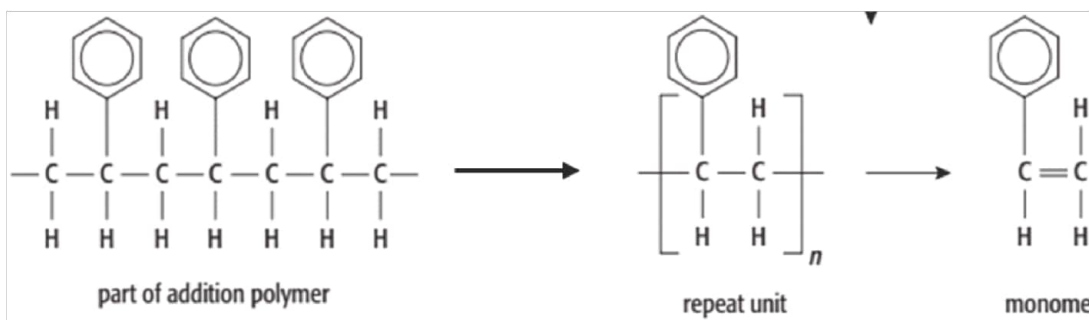
-CONH- links	Polyamide	Nylon-6,6, Kevlar
Benzene rings in the chain	Aromatic Polymer	PET or Kevlar

2. **Determining the "Repeat Unit":** To find the original monomers, one must first identify the smallest section that repeats itself in the section of the polymer.

- To find the repeating pattern, look for where the sequence starts to duplicate itself. Locate such duplicating sections in the backbone.
- Place brackets around one of these recurring sections and add the subscript n. This section within the brackets is the *repeat unit* of the polymer.

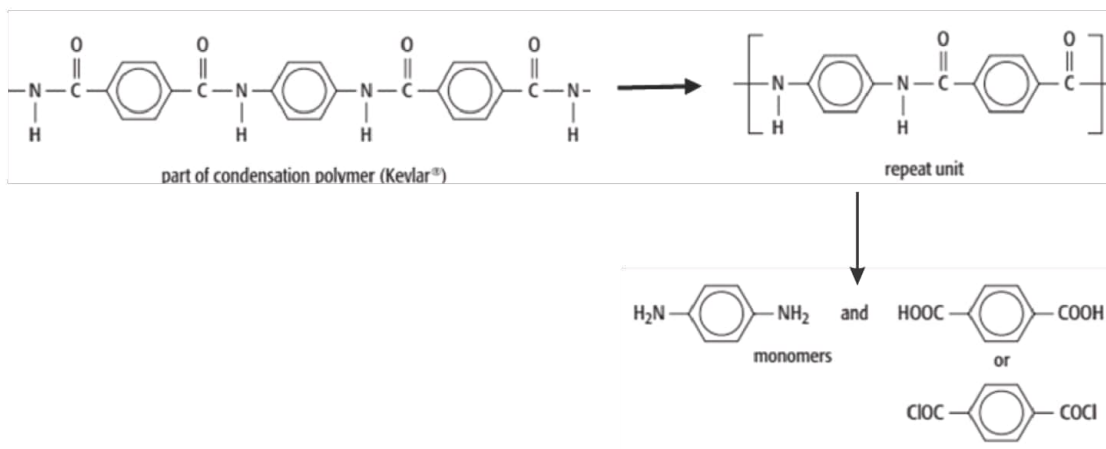
3. **Identifying the Monomer(s):**

a) For addition polymers, change the C-C single bond in the repeat unit back into a C=C double bond to find the monomer.



Identification of repeat unit and monomers (addition)

b) For Condensation polymers: Add water back in. Break the ester or amide bond. Add -OH to the C=O side and -H to the O or N side as given below.

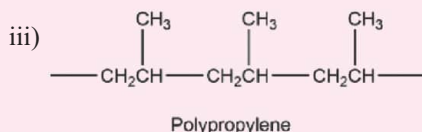
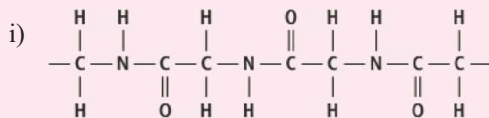


Identification of repeat unit and monomers (addition)



**Quick Check 26.2**

a) Identify the type of polymerisation and monomers forming the following polymer sections.



26.4 USING MONOMER(S) TO PREDICT THE TYPE OF POLYMERISATION

26.4.1 Addition polymers

When the given monomer(s) contains C=C bonds, addition polymerisation will take place. The examples include ethene, propene, phenyl ethene (styrene). Mostly homopolymers are formed through the addition polymerization, however, sometimes copolymerisation of two different monomers having double bond can also be achieved. Such an example is a copolymer of ethene and propenoic acid ($\text{H}_2\text{C}=\text{CH}-\text{COOH}$).

26.4.2 Condensation polymers

When there are two functional groups available for the formation of a bond or bridging linkage to create the polymeric chains, the condensation polymerisation takes place. Mostly, a small molecule is removed from the two monomers during the formation of the polymer. The two functional group may exist in a single molecule (e.g. lactic acid) or two different molecules, as in the case of nylon 6,6.

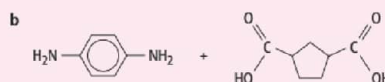
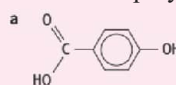
The common functional groups that can undergo condensation polymerisation are:

- amino group (NH_2) and carboxylic (COOH) group (polyamide and H_2O)
- amin group (NH_2) and acyl chlorides (COCl) (polyamide and HCl)
- carboxylic group (COOH) and alcohols (OH) (polyester and H_2O)
- acyl chlorides (COCl) and alcohols (OH) (polyester and HCl).

**Quick Check 26.2**

Give the structures of the polymers formed from the monomers. For each polymer identify the following:

- i. the repeat unit
- ii. the type of linkage present
- iii. the attractive force between the polymer chains.



26.5 CHALLENGE OF NON-DEGRADABLE POLYMERS

Plastic, such as poly(ethene), is the most widely used polymeric material on the globe. Conventional polymers are non-degradable, which means they can be broken down into simpler, non-toxic compounds. Due to this reason, they become an environmental nuisance after their disposal. These polymers become part of water bodies, soil, and natural habitats of living organisms. Therefore, scientists are now developing degradable polymers to cope with this issue. The plastic material is either buried underground or even disposed off in open air in the regions where the municipality system is not good.

- They stay in the environment for a very long time. This means they accumulate in landfills, oceans, and natural landscapes, leading to persistent pollution.
- They take up huge amounts of space in landfills because they do not decompose. As population grows, finding space for more landfills becomes difficult.
- Animals (especially marine life) can mistake plastic waste for food, leading to choking, internal injuries, or starvation. They can also get tangled in plastic debris.
- Over time, large pieces of non-degradable plastics break down into tiny pieces called **microplastics**. These microplastics spread everywhere, polluting soil, water, and even the air. They can enter the food chain and potentially harm human health.

This leads to the need for the development of two major classes of polymers biodegradable and photodegradable polymers.



Figure 26.5 A beach littered with non-degradable poly(alkene) waste

26.5.1 Biodegradable Polymers

The plastic that is naturally decomposed by microorganism into simpler non-toxic compounds when buried for a certain period is called **biodegradable plastic**. Plastics that contain natural polymers, such as starch, are degraded faster, as bacteria in the soil can attack natural polymers easily. Polyesters and polyamides are more biodegradable than poly(alkene)s because the soil organism can attack them better through hydrolysis into simpler components. Polyamides produce carboxylic acids and amines, whereas polyesters can be decomposed into carboxylic acids and alcohols. For, example, poly(lactic acid) (PLA) can enhance the biodegradability of plastic. **Figure 26.6** shows the degradation of a plastic material containing PLA after a certain period

26.5.2 Photodegradable Plastics

Some functional groups can absorb more energy from the sunlight in the form of UV light. Polymers with such functionalities can be degraded by light and are termed as photodegradable. Some polymers with carbonyl groups in their chains ($C=O$) have been developed due to their



enhanced photosorption. The absorption of the UV light weakens the bonds within the chain and forces between different chains of the polymers. This makes a polymer more biodegradable, thus accelerating its decomposition into less toxic compounds in the natural environment. However, photodegradable plastics cannot be used for longer time and recycling of such polymers is not efficient. Also, the plastic is buried in landfills where no light is available for photodegradability.

Because polyesters and polyamides can biodegrade under these conditions, it means they don't stay in the environment forever like some other plastics. This helps reduce the adverse effects of the plastic pollution. Scientists and engineers can use this knowledge to design materials that break down when they are no longer needed. For example, some medical implants or dissolvable stitches are made from polyesters that slowly break down in the body through hydrolysis.



Figure 26.6 Chemists are devising plastics that can be broken down by microorganism in soil or by light

26.6 POLYMERS IN ARTIFICIAL ORGANS

In biomedical science, polymers are very important for creating artificial organs. These are man-made devices designed to replace or support the function of damaged or diseased body parts. Polymers used in the body need to be biocompatible, mechanically suitable, sterilizable, durable and tunable.

They must not harm the body, cause allergies, or be rejected by the immune system.

Their strength, flexibility, or elasticity can be adjusted to match the body part they replace (e.g., flexible for blood vessels, strong for bones). The uses of various polymers in medical science are summarised in **Table 26.2**.

Table 26.2 Polymers in artificial organs

Application	Polymers Used	Key Properties & Functions
Artificial Blood Vessels (Grafts)	Poly(tetrafluoroethylene)(PTFE) and Poly(ethylene terephthalate) (PET)	Smooth surfaces to prevent blood clots; used to replace or bypass blocked vessels.
Artificial Heart Valves	Specialized Polyurethanes and Silicone	Highly flexible and durable; must be resistant to clotting.



Artificial Skin	Collagen (natural) and Poly(lactic acid) (PLA) (synthetic)	Acts as a scaffold for new skin growth; some are designed to dissolve as the wound heals.
Artificial Joints (Hip/Knee)	Ultra-high molecular weight polyethylene (UHMWPE)	Provides a smooth, low-friction surface to allow movement and resist wear.
Artificial Cornea	Poly(methyl methacrylate) (PMMA) and Hydrogels	Must be perfectly clear (transparent) and biocompatible to restore vision.

Exercise

Q1. MULTIPLE CHOICE QUESTIONS

I. Which pair of monomers reacts to form a polyester?

- a) Diamine and dicarboxylic acid b) Diol and dicarboxylic acid
c) Ethene and chloroethene d) Amino-carboxylic acid

II. What small molecule is eliminated when a diamine reacts with a diol chloride?

- a) Water (H₂O) b) Hydrogen chloride (HCl)
c) Ammonia (NH₃) d) Ethene (C₂H₄)

III. How do plasticizers affect PVC?

- a) Make it harder. b) Make it brittle
c) Reduce inter-chain forces, make it flexible
d) Increase melting point and conductivity

IV. What are the two monomers for Nylon 6,6?

- a) Vinyl chloride & Adipic acid b) Hexamethylenediamine & Adipic acid
c) Ethane-1,2-diol & Adipic acid d) Only Hexamethylenediamine

V. A polymer section is shown: [-CH₂-CH(CH₃)-CH₂-CH(CH₃)-]... What is the monomer, and what type of polymer is it?

- a) Propene; Addition b) Propene; Condensation
c) Ethene; Addition d) Ethene; Condensation

VI. Polyesters and polyamides are considered biodegradable because they:

- a) are natural polymers. b) break down in sunlight.
c) have small monomers. d) are hydrolysable ester/amide links.



VII. What are the products of alkaline hydrolysis (saponification) of a polyester?

- a) Carboxylic acid and alcohol b) Carboxylate salt and alcohol
c) Carboxylic acid and amine d) Carboxylate salt and amine

VIII. What are the products of acidic hydrolysis of a polyamide?

- a) Carboxylate salt and amine b) Carboxylic acid and alcohol
c) Carboxylic acid and protonated amine d) Carboxylate salt and protonated amine

IX. What is the primary cause of photodegradation in polymers?

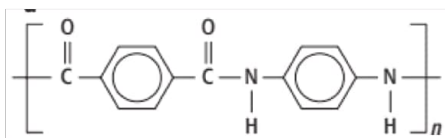
- a) Acidic hydrolysis b) Microorganisms
c) Absorption of UV light d) Alkaline hydrolysis

X. Poly(alkenes) are considered "chemically inert" because they:

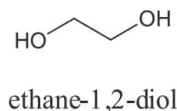
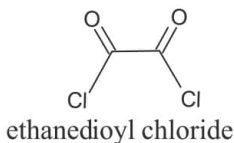
- a) have weak, easily broken bonds. b) have strong C-C and C-H bonds.
c) They react quickly with acids. d) They dissolve in water.

Q2. SHORT ANSWER QUESTIONS

- a) Kevlar[®] is a thermally and mechanically very stable but flexible polymer; a section of this polymer is given below:



- i) Name the characteristic linkage and type of polymerisation in its structure
ii) Identify the two functional groups that react to form it.
iii) Name the monomers from which it is formed.
- b) Explain why the reaction between an acyl chloride and ammonia is classified as a condensation reaction. Identify the small molecule that is eliminated during this reaction.
- c) For the following monomers:
- Predict the type of the polymer formed.
 - Draw the repeat unit and a section of the expected polymer.
 - Name this polymer systematically.
- d) For Nylon 6,6 (from 1,6-hexanediamine and 1,4-hexandioic acid acid):
- Name the linkage.
 - Name the small molecule eliminated.



- iii) Draw the repeating unit.
- e) For poly(chloroethene) (PVC)
- Name the monomer for PVC
 - Why can it undergo addition polymerization?
- f) State two properties of nylon that make it suitable for ropes and fishing nets.
- g) Give two industrial applications for PVC and two for Nylon.
- h) Draw the repeating unit of the polyester from propan-1,3-diol and benzene-1,4-dicarboxylic acid.
- i) State three distinct environmental problems caused by the disposal of non-degradable polymers.
- j) Name two different polymers used in artificial organs and state the specific application for each.

Q3. CONSTRUCTED RESPONSE QUESTIONS

- a) Describe the chemical role of plasticizers in polyvinyl chloride (PVC) and explain how this modification influences the polymer's industrial applications.
- b) Explain why poly(alkenes) like poly(ethene) pose a greater environmental challenge than polyesters and polyamides. Identify the chemical process that allows the latter to degrade.

DESCRIPTIVE QUESTIONS

- Q.4 Compare and contrast addition and condensation polymerization, giving details of the specific structural requirements for the monomers in each.
- Q.5 Illustrate the formation of two major condensation polymers.
- Q.6 Differentiate between the environmental degradation of poly(alkenes) and polyesters.



27

BIOCHEMISTRY

Student Learning Outcomes

[C-12-D-116 to C-12-D-139]

- ⊙ Explain the basis of classification and structure-function relationship of carbohydrates.
- ⊙ Explain the role of various carbohydrates in health and diseases.
- ⊙ Identify the nutritional importance of carbohydrates and their role as energy storage.
- ⊙ Explain the basis of classification and structure-function relationship of proteins.
- ⊙ Describe the role of various proteins in maintaining body functions and their nutritional importance.
- ⊙ Describe the role of enzyme as biocatalyst and relate this role to various functions such as digestion of food.
- ⊙ Identify factors that affect enzyme activity such as the effect of temperature and pH.
- ⊙ Explain the role of inhibitors of enzyme catalyzed reactions.
- ⊙ Describe the basis of classification and structure-function relationship of lipids.
- ⊙ Identify the nutritional and biological importance of lipids.
- ⊙ Identify the structural components of DNA and RNA.
- ⊙ Differentiate between the structures of DNA polymer (double strand) and RNA (single strand).
- ⊙ Relate DNA sequences to its function as storage of genetic information.
- ⊙ Relate RNA sequence (transcript) to its role in transfer of information to protein (translation).
- ⊙ Identify the sources of minerals such as iron, calcium, phosphorus and zinc.
- ⊙ Describe the role of iron, calcium, phosphorous and zinc in nutrition.
- ⊙ Explain why animals and humans have large glycogen deposits for sustainable muscular activities. Hibernating animals (polar bear, reptiles and amphibians) accumulate fat to meet energy resources during hibernation.
- ⊙ Identify complex carbohydrates which provide lubrication to the elbow and knee.
- ⊙ Describe fibrous proteins from hair and silk.
- ⊙ Explain how cholesterol and amino acid serve as hormones.
- ⊙ Identify insulin as a protein hormone whose deficiency leads to diabetes mellitus.
- ⊙ Explain the role of minerals in structure and function.
- ⊙ Identify calcium as a requirement for coagulation.
- ⊙ Identify how milk proteins can be precipitated by lowering the pH using lemon juice.

Biochemistry is the branch of science that deals with the study of chemical substances found in living organisms and the reactions they undergo. The biological compounds are complex molecules with the same types of functional groups those found in simple organic compounds, such as alcohol, amine, aldehyde, ketone, carboxylic acid, ester, and amide groups.



This chapter focuses on the essential biomolecules such as carbohydrates, proteins, lipids, and nucleic acids, featuring their structures, functions, and roles in cellular processes. In addition to these biomolecules, the roles of minerals and enzymes in biochemical processes will also be discussed.

27.1 CARBOHYDRATES

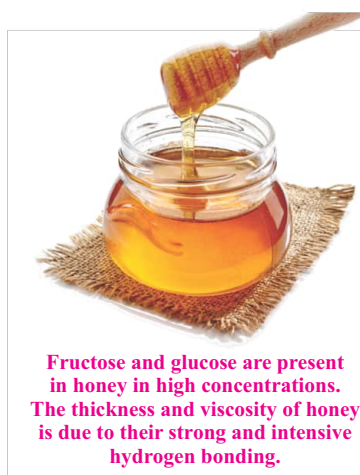
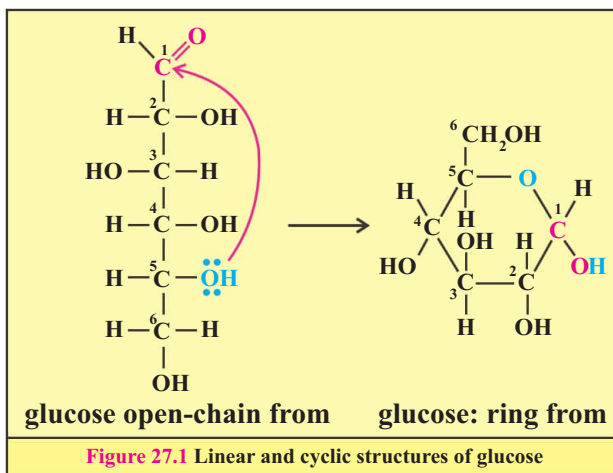
Carbohydrates are naturally occurring organic compounds including sugars, starch, cellulose, and substances found in bacterial cell walls and insect exoskeletons. These act as major sources of energy in our diet. All carbohydrates are hydrates of carbon. Chemically, they are polyhydroxy aldehydes or ketones or their derived compounds.

1. Monosaccharides are the simplest carbohydrates commonly known as sugars, e.g. glucose and sucrose. They cannot be hydrolysed further into simpler compounds. The general formula of monosaccharides is $C_n(H_2O)_y$, where n ranges from three to seven. A monosaccharide with three carbon atoms is a triose, one with four carbon atoms is a tetrose; a pentose has five carbons, and a hexose contains six carbons, etc. They are also classified according to the functional group present, such as a ketose or aldose containing ketonic and aldehydic group, respectively.

Glucose is an aldose whereas fructose is a ketose.

Monosaccharides exist either as open chains or ring-shaped molecules. Sugars with five carbon atoms (pentoses) or six carbon atoms (hexoses) are more stable and hence more abundant as cyclic structures than as open chain structures. In their solid form, they exist in ring form and in solutions, their molecules exist as linear structures. For example, fructose forms a five-membered ring known as furanose, whereas glucose has a six-membered ring known as pyranose. The linear chain and cyclic structures are interconvertible. The cyclisation of glucose from its linear structure is shown in **Figure 27.1**.

The presence of many hydroxyl groups ($-OH$) in the sugar molecules results in the extensive hydrogen bonding between their molecules. For this reason, monosaccharides exist in solid form in their pure form. In their solutions, they form extensive



hydrogen bonding with water molecules, making them highly soluble in water. Monosaccharides are excellent source of instant energy in the living organisms. Glucose is called blood sugar due to its presence in the human blood, while fructose is abundant in fruits and honey.

2. Disaccharides

Disaccharides consist of two monosaccharide units joined together via glycosidic linkage, generally with the formula $C_{12}H_{22}O_{11}$. Among the most common disaccharides are sucrose, lactose and maltose. They are formed through a condensation reaction, when the hydroxyl group of one monosaccharide combines with the hydrogen of another monosaccharide through a covalent bond, releasing a molecule of water. The bond $C-O-C$ is known as the glycosidic bond. For example, sucrose which is a common table sugar, is a disaccharide of glucose and fructose as given in **Figure 27.2**.

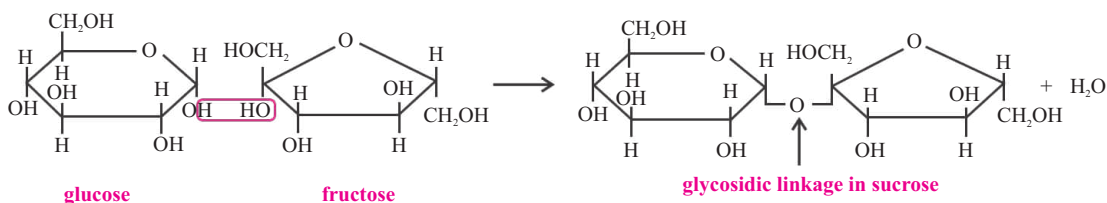


Figure 27.2 Formation of the Sucrose molecule

3. Polysaccharides

Polysaccharides are large molecules consisting of a large number of monosaccharide units joined together. They have high molecular mass, having general molecular formula, $(C_6H_{10}O_5)_n$. Polysaccharides give simple sugars, i.e., monosaccharides on hydrolysis. Common examples are starch, glycogen, cellulose and pectin. Starch is the main storage of energy in plants, and consist of glucose units. It has two components, amylose and amylopectin.

Amylose has a long, unbranched chains with many glycosidic linkages. While amylopectin is a compact highly branched structure consisting of many glucose units (**Figure 27.3**). Amylopectin is soluble in water, while amylose is insoluble. Potato, sugar beet, rice, and grains have large quantities of starch in them.

Cellulose is the major structural material found in plant cell walls. It consists of glucose units (up to 2500) to form long unbranched chains linked by glycosidic bonds (**Figure 27.3**). These chains form strong hydrogen bonds with each other, making cellulose rigid and insoluble in water. It makes most of the plant leaves, branches, and trunk. It is very important in human food in the form of fibre, which improves the gut health. **Glycogen**, or animal starch, is a polymer of glucose that is stored in the liver and muscles of animals. It is also called the 'animal starch'. The structure of glycogen is very similar to that of amylopectin, but it is more highly branched, making it different from starch. However, there is no amylopectin structure in glycogen.



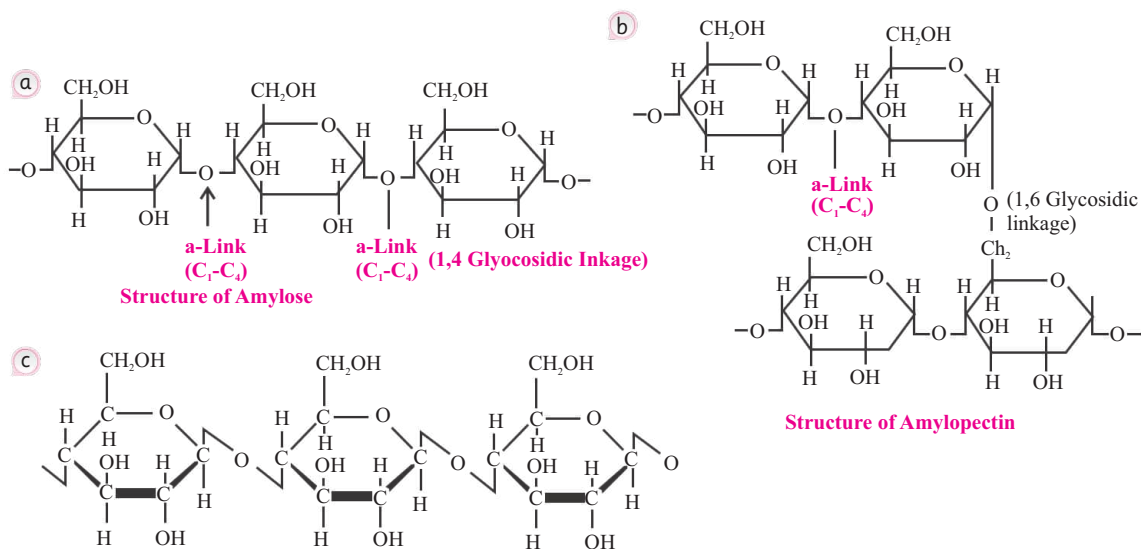


Figure 27.3 Structure of a) amylose, b) amylopectin in starch, and c) cellulose

27.1.1 Nutritional Importance of Carbohydrates

Carbohydrates have a complex role in the human health. Although, they are essential for energy and nutrient intake, the type and amount consumed have a major effect on health. By selecting the right carbohydrates and balanced intake, we can reduce the risk of diseases. The following are important physiological functions of carbohydrates and the risk of imbalance in their intake.

1. Simple sugars like glucose are the primary source of energy for cells. They are easily absorbed and metabolized to release energy, with 1 g of glucose providing about 15.6 kJ. Excess glucose is stored as glycogen in the liver and muscles. Normally, blood glucose levels range between 70-110 mg/dL, though it may fluctuate slightly during the day. These levels are controlled by the hormones insulin and glucagon. If blood glucose levels rise above the normal range, it can lead to diabetes, a chronic condition that occurs when the pancreas does not produce enough insulin or when the body cannot effectively use the insulin it produces. Uncontrolled diabetes can cause hyperglycemia (high blood sugar), which, over time may damage body systems, particularly nerves and blood vessels. On the other hand, insufficient carbohydrate intake can result in fatigue and reduced physical and mental performance.
2. The main function of fructose is to provide energy during metabolism in the body. Its high intake causes obesity, resulting in an excessive accumulation of fat in the body. Diets high in refined sugars have been associated with a higher risk of chronic diseases such as diabetes, heart disease, and certain cancers. Conversely, complex carbohydrates and fibers are protective with multiple health benefits. When the body has sufficient carbohydrates for its energy needs, it utilizes these instead of breaking down proteins or fats for fuel and energy production.

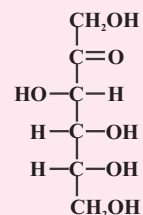




Quick Check 27.1



- a) The linear structure of fructose is given here.
 - i. Show the conversion of this structure into the cyclic structure.
 - ii. Predict whether fructose is soluble in water or not. Explain your reasoning.
 - iii. Predict the physical state of fructose in its pure form by analyzing its structure.
- b) What is glycosidic linkage? Show how it is formed between fructose and glucose.
- c) Briefly describe any two functions of carbohydrates and how these functions are related to their molecular structures.



27.2 PROTEINS

Proteins are large, complex macromolecules found in all living organisms abundantly. Our skin, hair, haemoglobin in blood (red pigment), and muscles, all are proteins. Proteins play key roles in the human body from building the tissue structure to various functions of the body cells and organs. Any change in the structure or function of a protein may alter the body to behave abnormally.

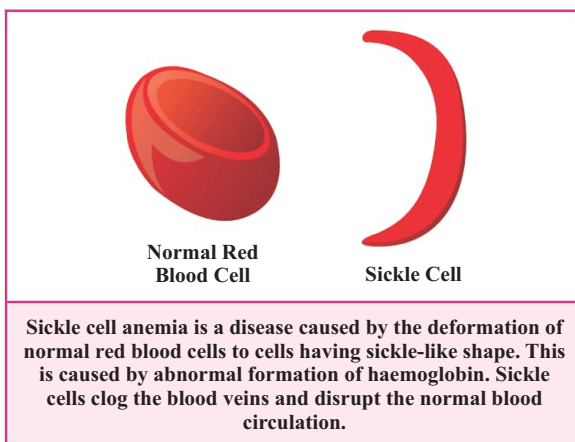
When proteins are completely hydrolysed, they yield amino acids. About 20 different amino acids link together in various sequences to create a wide variety of proteins.

27.2.1 Structure-Based Classification

Proteins are linear chains of amino acids that are linked together by peptide bonds. A peptide bond is an amide bond that forms when the $-\text{COO}^-$ group of one amino acid reacts with the $-\text{NH}^{3+}$ group of the adjacent amino acid to form a linear polymer. The long chains of amino acids formed by many peptide linkages are called polypeptide chains. Each protein has specific polypeptide chains, which determine its structure and function.

To understand the complex function of a protein in an organism, it is necessary to determine the three-dimensional structure of its polypeptide chain. Proteins are organized into four structural levels: primary, secondary, tertiary, and quaternary.

Primary structure: The primary structure of a protein is the specific linear sequence of amino acids linked by peptide bonds in a polypeptide chain. This sequence determines how the protein folds into its three-dimensional shape, which in turn defines its biological function. Even a small change in a single amino acid can alter the protein structure and impair its function. For example,



proteins like albumin (with about 400 amino acids) and insulin rely on their precise amino acid sequences to function properly.

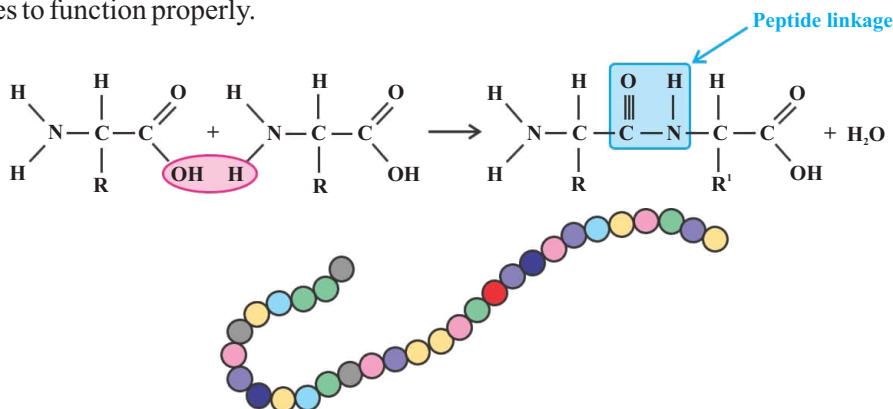


Figure 27.4 The peptide chain formation by the peptide bonds between amino acids

Secondary structure: The secondary structure of a protein arises when the backbone atoms form hydrogen bonds within a polypeptide chain, producing regular patterns such as α -helices and β -pleated sheets. In an α -helix, hydrogen bonds form along a single chain, creating a coiled, spiral structure (e.g., keratin). In contrast, β -pleated sheets form when hydrogen bonds occur between adjacent polypeptide strands, giving a folded, sheet-like structure (e.g., silk fibroin) as shown in **Figure 27.5**.

These structural arrangements provide stability and flexibility, contributing to the overall three-dimensional shape of a protein, which is essential for its specific biological function.

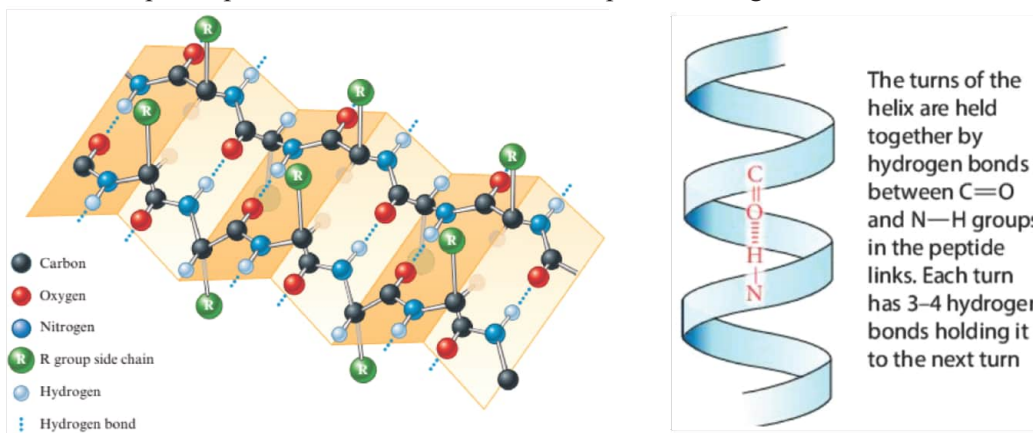


Figure 27.5 Formation of α -helix and β pleated sheets from the primary amino acid chains

Tertiary structure:

The tertiary structure of a protein is the overall three-dimensional shape formed when a polypeptide chain folds due to interactions between side chains (R-groups), including hydrogen bonds, ionic bonds, hydrophobic interactions, and disulphide bridges. These interactions cause the chain to twist and bend into a specific shape, often forming globular proteins. This three-dimensional structure determines the protein function. For example, in enzymes, the precise



shape of the active site allows specific binding to the substrate, enabling catalytic activity. Any change in this structure can affect the enzyme activity.

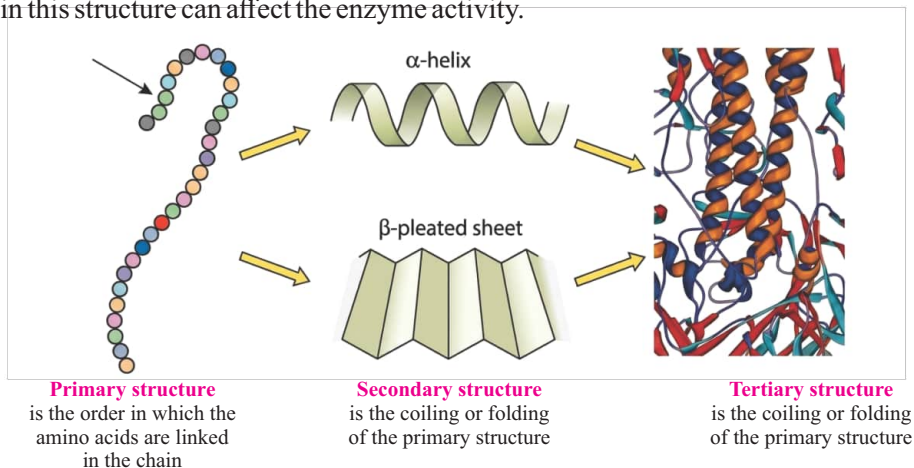


Figure 27.6 From primary amino acid chains to tertiary structure of proteins



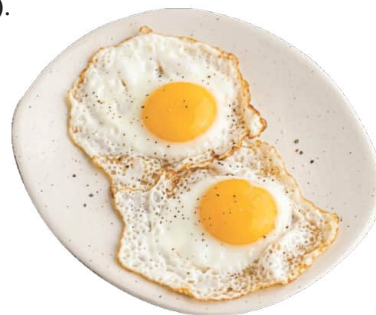
Keep in Mind

Some proteins have quaternary structures too. The quaternary structure arises when two or more folded polypeptide chains (subunits) associate by interactions such as hydrogen bonds, ionic (salt) bridges, hydrophobic interactions, and sometimes disulphide bonds.

Based on the overall shape of proteins which they take after tertiary or quaternary structure formation, they are divided into two main classes:

Fibrous Proteins: These proteins consist of long, rod-like, or thread-like molecules with polypeptide chains running parallel and linked by strong intermolecular hydrogen bonds or disulphide bonds to form fibres. These proteins are generally insoluble in water, mechanically strong, and stable. Therefore, they serve as the structural polymers. For example, collagen (connective tissue), keratin (hair, nails, skin), and myosin (muscle).

Globular Protein: If the shape of the whole protein molecule is spherical or ovoid, it is a globular protein. Most worker proteins (functional proteins), such as enzymes, hormones, and nutrients are globular proteins. Globular proteins are more sensitive to heat and pH. The white of an egg is hardened on heating as the hydrogen bonding between the chains is disrupted and the chains open up. Due to the same reason the milk protein casein is coagulated when the pH of the solution is changed by adding some lemon juice. This is called **denaturing of proteins**.



Egg white is a globular protein

27.2.2. Biological Functions of Proteins

Proteins can be grouped into different categories based on their biological and metabolic functions. There are some proteins which control or regulate specific physiological activities, such as growth, development, metabolism, and reproduction. These are called **Hormonal**



Proteins. An example is insulin, which is produced by pancreas in our bodies and is responsible for regulating the movement of glucose from the blood into cells.

Storage Proteins provide essential nutrients for the growth of the germinating seedlings or for the early development of animals. Ferritin is a storage protein found in some bacteria, and in plant and animal tissues, where it stores iron.

Structural Proteins are most abundant proteins in a vertebrate body. They are fibrous, or threadlike, which maintain the shape and give structural support, such as keratin in hair, fibrin in blood clots and collagen. They also forms the matrix of skin, ligaments, tendons, and bones.

Contractile Proteins, such as actin and myosin, make up the thin and thick filaments of a muscle involved in contraction and relaxation movement of the muscle fibre.

Defensive proteins help organisms to fight infection and prevent injury in the body. For example, antibodies recognize and bind to specific antigens (proteins present on pathogens) with high affinity, immediately destroying the antigens.

Transport or Carrier Proteins aid in the movement of molecules and ions across cell membranes. For example, iron atom attaches with oxygen atom through the hemoglobin molecules, as the blood travels between the lungs and the tissues.

Receptor Proteins are located within the cell's membrane and they receive chemical signals and responses from and to the cells.

Regulatory Proteins play a role in controlling cellular and physiological activities, such as insulin, which regulates sugar metabolism and growth hormone.



Quick Check 27.2



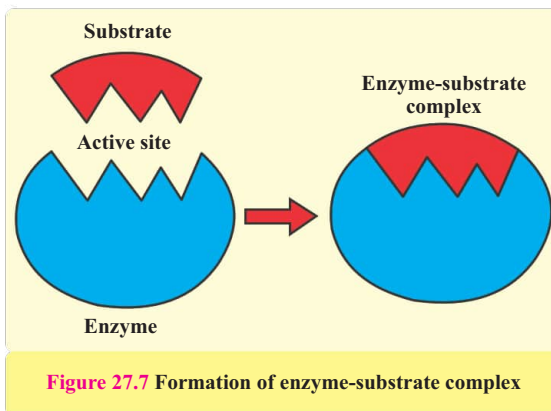
- Keratin is a structural protein found in hair, nails, horn, hoofs, wool, feathers, enamel of teeth and outer layer of skin, where it gives strength and flexibility. It is not easily denatured. Which bond do you expect is responsible for this; hydrogen bond or disulphide bond? Explain.
- How can two peptides with identical type and number of amino acids differ in their primary structure?
- What are the two most common types of secondary protein structures in our body?
- Why does a denatured protein no longer function properly?
- The white of egg solidifies on heating. Explain why it happens.

27.3 ENZYMES AS BIOCATALYSTS

Enzymes are proteins that acts as biological catalysts needed for various chemical reactions that take place in living organisms.

An enzyme speeds up a biochemical reaction to an extent that would be impossible without it. For example, one molecule of carbonic anhydrase in the blood can convert about one million of carbon dioxide and water molecules to carbonic acid in one minute.

An enzyme has a special site on its surface, called the active site, which binds the substrate molecule and converts it into the products.



Enzymes are highly specific, each enzyme acts on only one particular substrate molecule. This specificity is due to the active site of the enzyme, which has a unique shape that allows only a specific substrate to fit into it. The random movement of enzyme and substrate molecules, allows the substrate to enter the enzyme active site. As a result of this, a temporary enzyme–substrate complex is formed. After this, the products are released, and the enzyme remains unchanged and free to bind with another substrate molecule (**Figure 27.7**).

This mechanism can be understood by using the lock and key model proposed by Emil Fischer in 1894. According to this model, the lock is the enzyme and the key is the substrate. Only the correctly shaped key (substrate) fits into the keyhole (active site) of the lock (enzyme).

27.3.1 Factors Affecting Enzyme Activity

The important factors that influence the activity of the enzyme reaction are temperature, pH and change in substrate and enzyme concentration. The enzyme action may also be affected in the presence of some other substances such as co-enzymes, activators and inhibitors.

Temperature and pH: The temperature and pH that give maximum enzyme activity are called optimum temperature and pH, respectively. If the temperature and pH are disturbed from the optimum values, it can deactivate the enzyme action. The enzymatic reactions in the human body and other organisms occur best at or around 37 °C and a pH range of 6.4–6.9.

Concentration of enzyme and substrate: The rate of an enzymatic reaction increases as the enzyme or substrate concentrations are increased. This is because with more substrate and enzyme molecules the available sites for binding to enzyme are also abundant. Therefore, the reaction rate increases due to the formation of more enzyme-substrate complex. However increasing the substrate concentration beyond a limit can slow down the reaction.

27.3.2 Role of Inhibitors in Enzyme-Catalyzed Reactions

A variety of small molecules or ions that cause enzymes to lose their catalytic activity are called inhibitors. Although, different inhibitors behave differently, but they all prevent the active site from binding with a substrate.

Reversible inhibitors are also termed as competitive inhibitors as they are the molecules having the same shape as that of the substrate. The substrate and the inhibitor compete for the active site of the enzyme. The more the inhibitor, the more deactivated is the enzyme for the original substrate. For example, the substrate butanedioate (succinate ion) is oxidized by the enzyme dehydrogenase succinate. The propandioate ion (malonate) can inhibit this enzyme due to its resemblance with the substrate butanedioate.

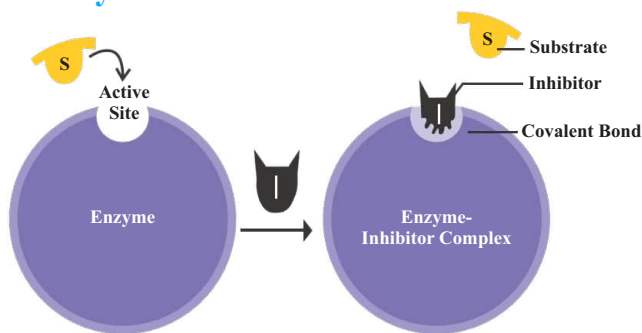


Figure 27.8 Action of reversible inhibitor



Non-competitive inhibitors (irreversible) are small ions or molecules that change the shape of the active site such that it is no longer available for the substrate. Thus, such inhibition is irreversible and it sometimes causes severe human health issues or even death. An enzyme to which an irreversible inhibitor, such as poisons, antibiotics, anti-metabolites and some drugs, is attached, loses enzymatic activity permanently (**Figure 27.9**).

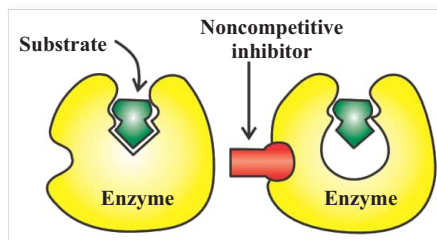


Figure 27.9 Action of non-competitive inhibitor

Penicillin is an irreversible inhibitor that blocks the enzyme trans-peptidase. This enzyme acts for the synthesis of the bacterial cell wall. Thus insulin kills bacteria by disrupting the cell wall enzyme.



Quick Check 27.3



- How do enzymes differ from inorganic catalysts?
- What is the effect of decreasing and increasing temperature affect an enzyme activity?
- Differentiate between competitive and non-competitive inhibitors.
- An enzyme is a protein. When the pH is changed, the function of the enzyme is disturbed. In terms of the protein structure, explain how and why it happens so?



The cobra venom has an enzyme PLA₂, which can disrupt the cell wall of the red blood cell. This result in hemolysis, which causes swelling of the affected organ and ultimately death.

27.4 LIPIDS

Lipids are a class of organic compounds found in animals and plants that include fats and phospholipids (such as those in the cellular membrane), steroids, and terpenes (essential oils). Unlike, polysaccharides and proteins, lipids are not polymers, lacking repeating monomeric unit. They are hydrophobic but soluble in organic solvents. Lipids perform many different functions in living systems as fuel molecules, signal molecules, components of membranes, hormones and intracellular messengers. Lipids are broadly classified into simple lipids, complex lipids and derived lipids based on their chemical composition.

27.4.1 Simple Lipids

These are esters of fatty acids with different type of alcohols. Simple lipids are sub-classified based on the type of alcohols, such as fats, oils, and waxes.

Triglycerides

Animal fats and vegetable oils are esters formed from one glycerol molecule and three fatty acids, forming triglycerides as shown in **Figure 27.10**. The fatty acids may be similar or different. This structure makes them efficient energy storage molecules and also provides insulation, protection of organs, and a source of fat-soluble vitamins.

Saturated fatty acids make lipids that are solid at room temperature and are called fats.



Oil contain unsaturated fatty acids with one or more double bonds.

The hydrophobic nature of fatty acid chains makes fats insoluble in water but soluble in organic solvents. In the body, this property allows them to form insulating layers under the skin and cushioning around organs such as the kidneys, helping in temperature regulation and protection.

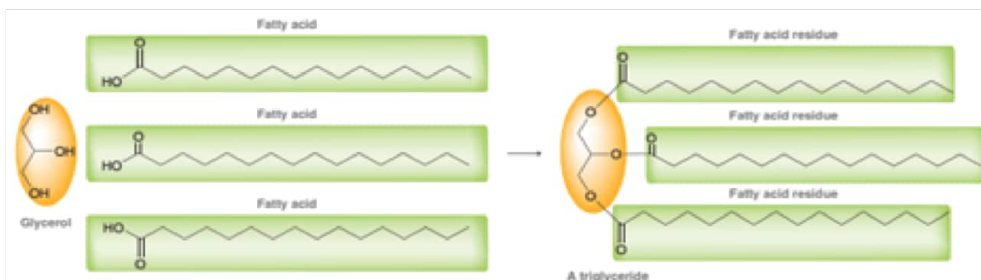
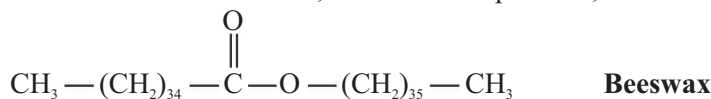


Figure 27.10 Glycerol and fatty acids combine to give triglycerides.

Waxes

Most waxes are made up of long fatty acid chains esterified to long-chain alcohols. Both chains are nonpolar and hydrophobic (water-repelling). Because of the hydrophobic nature of waxes, they serve as barrier by forming protective coatings, which prevents water from sticking on the surface. For example, those seen in nature include beeswax, the oil in a whale's head, the feathers of some aquatic birds and plant waxes. These are widely used in pharmaceutical, cosmetic and other industries in the manufacture of lotions, ointments and polishes, etc.



27.4.2 Compound Lipids

These are esters of fatty acids with alcohols containing an additional group, such as phosphate, nitrogenous base, carbohydrate, protein etc. A phospholipid is similar to a fat molecule but has only two fatty acids attached to glycerol instead of three. The third hydroxyl group of glycerol is linked to a phosphate group, which makes the molecule polar. The hydrocarbon tails are hydrophobic, while the phosphate group and its attached components form a hydrophilic head that has an affinity for water (**Figure 27.11**).

When phospholipids are added to water, they turn into a double-layered sheet called a “bilayer”. The polar ends face outward and the non-polar ends clustered together in their own layer. It forms the structure of all cell membranes. Some liposomes are artificial phospholipids that are used for hydrophilic drug delivery.

Lipoproteins are complexes of lipids and proteins that transport hydrophobic lipids (like cholesterol and triglycerides) in the bloodstream.

Glycolipids are lipids with carbohydrate (sugar) groups attached, mostly found in nervous tissue.

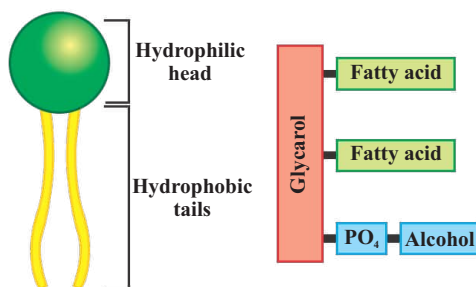


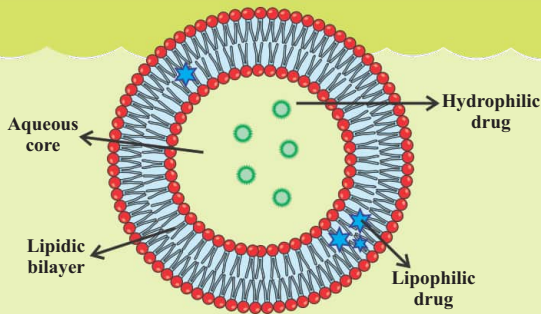
Figure 27.11 Phospholipids basic structure





Did You Know?

Liposomes are ideal for delivering hydrophilic (water-loving) cancer drugs because their structure, a lipid bilayer surrounding a watery core, allows them to encapsulate water-soluble agents, shielding them from degradation and enabling cellular uptake. They improve solubility, provide targeted delivery to the tumor cells.



27.4.3 Derived or Associated Lipids

They are the hydrolytic products of simple and compound lipids, which have the same characteristics as of lipids, e.g. fatty acids, glycerol, steroids, lipid soluble vitamins, etc. They are not fats themselves, but come from fats. They perform important roles in the body including energy and hormone production, cell structure, nerve health, and vitamin function.

Steroids

Steroids are not formed from fatty acids but have some lipid like properties. They consist of three cyclohexane rings and one cyclopentane ring fused together called steroid nucleus (**Figure 27.12**). The four rings in the steroid nucleus are named as A, B, C, and D. Many steroids also have the $-OH$ functional group, which put them into the alcohol class (sterols). There are numerous steroids in the biological systems, including cholesterol, bile salts, vitamin D and steroid hormones.

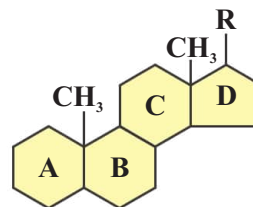


Figure 27.12 Steroid ring structure

Terpenes

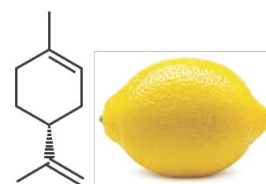
Lipids present in plants include a wide variety of hydrocarbons called terpenes, which are built from isoprene ($CH(CH_3)=CH-CH_2-CH_3$) units. These hydrocarbons and their oxygenated derivatives have fewer than 40 carbon atoms. Terpenes that contain 40 carbon atoms are known as carotenoids.

27.4.4 Nutritional and Biological Importance of Lipids

A major function of lipids is to serve as a primary source of energy storage in living organisms. They provide more energy per gram than carbohydrates, because when oxidised to carbon dioxide and water, they have a higher caloric value.

Lipids act as solvents for the transport of fat vitamins (A, D, E and K) and help in their absorption in the intestinal cells and later into the bloodstream. We can meet our vitamin requirements by consuming foods that contain these fat-soluble vitamins. These vitamins should

be eaten with a bit of healthy fat. Fats provide insulation to the body from water, heat, and electricity due to their non-polar nature.



Limonene
(a terpene)

Limonene, a terpene in lemon





Did You Know?

Animals, such as polar bears, reptiles, and amphibians, store extra fat when hibernating. Hibernation is a condition when animals significantly slow down their metabolic rate, body temperature, heart rate and breathing to save energy for the periods when food is scarce. During this period, metabolic rates decrease extremely. Fat is a more concentrated source of energy compared to glycogen, allowing animals to utilize stored fat effectively while minimizing energy consumption.



Quick Check 27.3



- Why lipids are not soluble in water?
- What are three major functions of lipids in the human body?
- What type/s of lipid do/does not contain fatty acids? Give examples.
- Vegetable oil and vegetable ghee both are triglycerides. What is the major structural difference between the two?

27.5 NUCLEIC ACIDS

Nucleic acids are large biomolecules that store and transmit genetic information. They are polymers made up of smaller units called nucleotides. Nucleic acids are formed from the nucleotide chains containing alternating sugar and phosphate groups with organic bases attached to the sugar molecules. The sugars are ribose in RNA and deoxyribose in DNA; these are five-membered sugar molecules. Nucleotides joined together by a phosphodiester linkage with the '5' and '3' carbon atoms of the sugar to form nucleic acids (**Figure 27.13**). The process is repeated up to several million times to make a polynucleotide. Phosphodiester linkages are strong covalent bonds, which gives strength and stability to the polynucleotide chain.

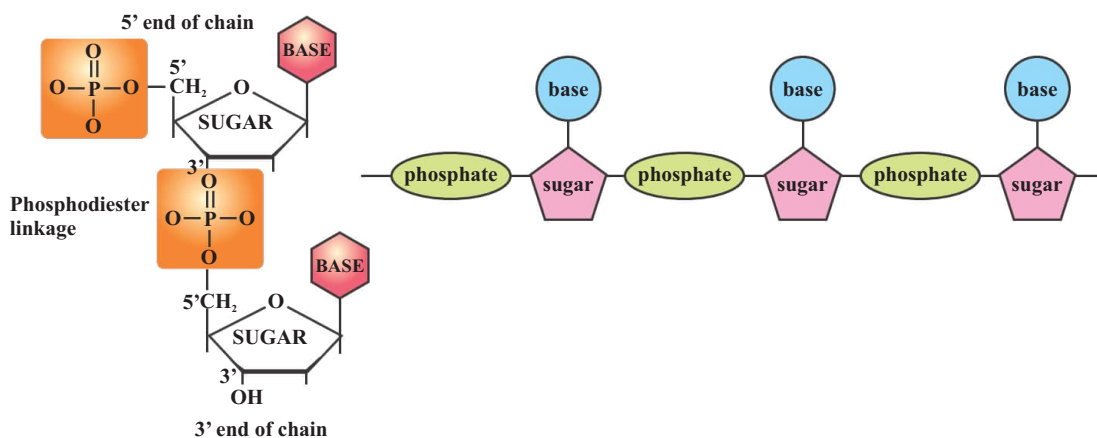


Figure 27.13 The general structure of nucleotide chains in nucleic acids (DNA and RNA)

27.5.1 Deoxyribonucleic Acid (DNA)

DNA is present in the nucleus of every living cell. It is a coded plan (or 'blueprint') for making proteins, which are, in turn, vital for life. Each specific protein is made by a specific gene; a section of DNA (**Figure 27.14**). The genetic information of an organism is stored in DNA



molecules that carries the genetic instructions for the development, functioning, growth, and reproduction of all living organisms. The double helix structure of DNA allows for the storage of information through the sequence of its four different nitrogenous bases and transmit genetic information efficiently and accurately for the synthesis of proteins.

These genes are organised into larger units called **chromosomes**; in humans, we receive 23 pairs of these from our parents. While nearly every cell in the body carries the full set of 23 pairs, each cell is a different specific pectine. For instance, a red blood cell activates the gene for haemoglobin while keeping the gene for keratin switched off.

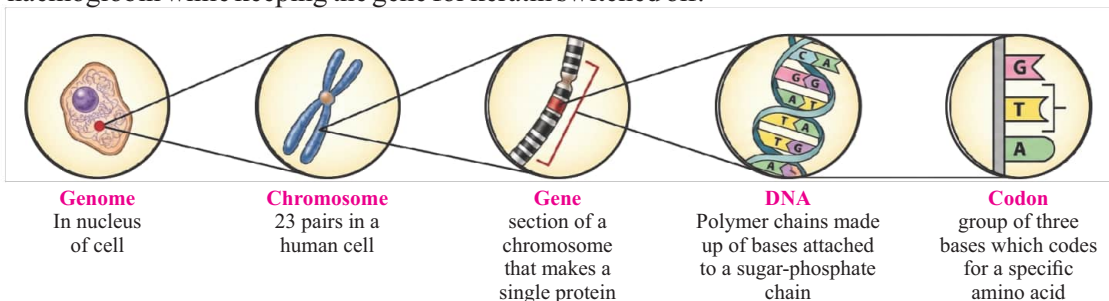


Figure 27.14 DNA; from genome to codon

The structure and function of DNA

In 1953, James Watson and Francis Crick showed that DNA consists of two polynucleotide chains. Each chain forms a right-handed helical spiral and the two chains coil around each other to form a double helix. The two polynucleotide chains are not identical but opposite to each other due to base pairing i.e. '3' end of one faces the '5' end of the other. Each chain has a sugar-phosphate backbone with bases which project at right-angles and held by weak hydrogen bonds with bases of the opposite chain across the double helix. Adenine (A) is always opposite to thymine (T), and guanine (G) and cytosine (C) are opposite to each other. There are two hydrogen bonds between A and T pair, and three hydrogen bonds between G and C pair (**Figure 27.15**).

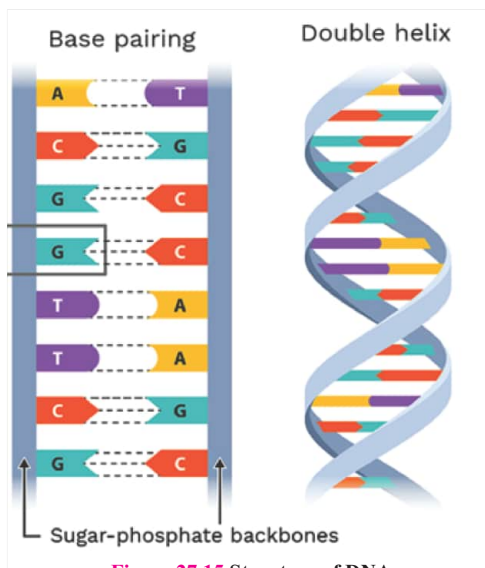


Figure 27.15 Structure of DNA

Genes are the specific regions of DNA that carry genetic information. They provide instructions for the cell to make a particular protein. One important process of DNA is its self-replication. Replication is the process during the cell cycle in which DNA is copied, so that when the cell division occurs, each new cell receives a complete set of genetic material. In this way, the genetic information is transmitted from one cell to the daughter cells and to the next generation.



27.5.2 Structure of RNA

RNA is usually single stranded unlike DNA, but the chain can fold back to itself to form a helical loop. A ribonucleotide chain in the RNA contains ribose, four nitrogenous bases (A, U, G, and C), and the phosphate group as given in **Figure 27.16**. There are three major types of RNA in the cells.

Messenger RNA (mRNA): it carries the genetic blueprint copied from the DNA in the nucleus.

Ribosomal RNA (rRNA): it helps to make up the ribosome.

Transfer RNA (tRNA): it translates the nucleotide sequence in mRNA into the corresponding sequence of amino acids in a protein.

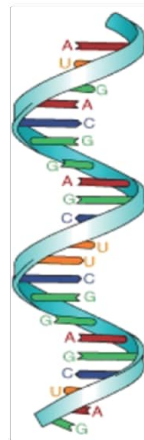


Figure 27.16 Structure of RNA

27.5.3 The Genetic Code and Protein Synthesis

Protein synthesis is a complex process involved in transferring genetic information encoded in the DNA. Two processes, transcription and translation are required for transmitting genetic information for the synthesis of numerous proteins in living organisms. The process starts with replication, i.e. making copies of DNA **in the nucleus, the genetic instructions for making a protein are copied from a DNA gene into mRNA; this process is called transcription**. When the mRNA strand is complete, it detaches from DNA and enters the cytoplasm, where it attaches to ribosomes. At the ribosomes, the code carried by mRNA is read and converted into a specific sequence of amino acids, forming a protein through the process called **translation**. Amino acids are arranged according to the sequence of bases in the RNA. The tRNA molecules release their amino acids, which join together in a chain, forming a polypeptide chain. **The polypeptide chain grows as bonds form between the amino acids, and finally the complete protein molecule is formed.**

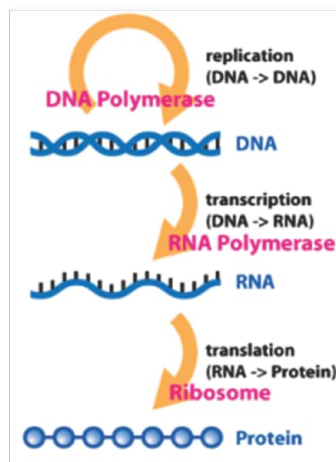


Figure 27.17 Protein synthesis



Quick Check 27.4



- Compare the stability provided by the **sugar-phosphate backbone** versus the **inter-chain base pairing**. In your answer, refer to the specific types of bonds and the number of bonds formed between:
 - ✓ Adenine (A) and Thymine (T)
 - ✓ Guanine (G) and Cytosine (C)
- How the DNA and RNA are chemically different? What are the similarities between these two?
- Nearly every cell in the human body contains the exact same 23 pairs of chromosomes, yet a red blood cell produces haemoglobin while a skin cell produces keratin. Explain why.

27.5 MINERALS

Minerals are inorganic substances, necessary for the maintenance of certain physiochemical life processes vital for living organism. Although, they produce no energy, they have important functions to perform in various activities.



Minerals may be broadly classified as macro (major) or micro (trace) elements. The macro-minerals include calcium, phosphorus, sodium and chloride, while the micro-elements include iron, copper, cobalt, potassium, magnesium, iodine, zinc, manganese, molybdenum, fluoride, chromium, selenium and sulfur. The macro-minerals are required in amounts greater than 100 mg/dL and the micro-minerals are required in amounts less than 100 mg/dL.

Table 27.1 Sources and role of iron, calcium, phosphorus and zinc in nutrition

Mineral	Sources	Role in Nutrition
Iron	Liver, meat, egg yolks, nuts, enriched or whole grains, beans, peas and lentils.	Hemoglobin synthesis found in red blood and myoglobin in muscle cells. Needed to carry oxygen.
Calcium	Milk and other dairy products, greens, broccoli, and salmon, sardines, beans, peas and lentils.	Helps in the formation of bones and teeth, normal blood clotting, muscle contraction and relaxation, heart function and nerve function.
Phosphorus	Meat, fish, poultry, eggs, milk, cereal products.	Aids in the formation of bones and teeth. Regulates the release and use of body energy (ATP). It helps to carry fat in the body as a part of phospholipids. Maintains normal acid/base balance in the body.
Zinc	Meat, seafood, whole grains.	Component of many enzyme systems e.g. involved in growth, immune function, etc. Found in the hormone insulin.
Sodium, potassium, and chloride	Salt, meat, sea food, fruit juices, vegetables, lentil	Maintaining fluid balance, nerve transmission, and muscle function

Exercise

Q1. Multiple Choice Questions:

I. Glucose is a building block for all, except:

- a) cellulose
- b) glycogen
- c) inulin
- d) starch

II. Which one of the following is not an aldose?

- a) glucose
- b) galactose
- c) mannose
- d) fructose



III. Which one of the following element is not present in all proteins?

- a) carbon
b) hydrogen
c) nitrogen
d) sulphur

IV. In DNA, the linkages between different nitrogenous bases are:

- a) phosphate linkage
b) hydrogen bonding
c) glycosidic linkage
d) peptide linkage

V. Which one of the following nitrogenous bases is not common to RNA and DNA?

- a) cytosine
b) adenine
c) thiamine
d) uracil

VI. Waxes are the esters of:

- a) glycerols
b) sterols
c) ethanol
d) long-chain fatty acids and alcohols.

VII. A cell membrane is made up of:

- a) phospholipid bilayer
b) lipid
c) phospholipid
d) only protein

VIII. The bonds in protein structure that are not broken on denaturation.

- a) hydrogen bonds
b) peptide bonds
c) ionic bond
d) disulfide bonds

IX. The backbone of nucleic acid structure is constructed by:

- a) peptide bonds
b) glycosidic bonds
c) phosphodiester bridges
d) all of them

X. Which element prevents the development of tooth decay:

- a) fluorine
b) calcium
c) phosphorus
d) sodium

Q2. SHORT ANSWER QUESTIONS:

- a) What role does glycogen play in the human body?
- b) Point out the main structural difference between the compounds in each of the following pairs.
- i) Glucose and fructose
ii) Cellulose and starch
iii) Competitive and non-competitive inhibition
iv) Glycolipids and lipoprotein
- c) Which class of biomolecule contains each of the following linkages? Describe the function of each linkage.
- i) Glycosidic
ii) Peptide
iii) Ester
iv) Phosphodiester
- d) How the tertiary structure of proteins is formed?
- e) In what way fats and oils are different?
- f) Describe the structure of steroids. Write a note on the functions of cholesterol.



- g) Describe the mechanism of enzyme action.
- h) Why does an enzyme catalyze a reaction of only a specific substrate?
- i) Name different RNAs and discuss their function.
- j) What are some sources of potassium, iron, calcium, magnesium and zinc in our diet?
- k) What is the role of iron in the body?
- l) How enzyme inhibitors are important in our body and medicine?

Q3. Construction Response Questions

- a. Why does the digestive enzyme pepsin have an optimum pH of 2?
- b. How condensation of sugars and condensation of amino acid are same?
- c. Why is cholesterol included in the lipid family?
- d. Why fats and oils are also called triacylglycerols?
- e. How hydrogen bonding is important in the double helix of DNA?
- f. If the sequence T-A-C-C-G-A located on one strand of DNA, what sequence would be seen opposite to it on the other strand?

DESCRIPTIVE QUESTIONS

- Q4. Classify and describe the structure of polysaccharides.
- Q5. How the structure of proteins support its function. Describe at each structure level.
- Q6. Write an account of classification of lipids with suitable examples.
- Q7. What are nucleic acids? Describe the roll of DNA and RNA in the protein synthesis.



28

CHROMATOGRAPHY

Student Learning Outcomes

[C-12-E-29 to C-12-E-33]

- Describe the terms stationary phase, mobile phase, R_f value, baseline, and solvent front.
- Explain the principles and applications of thin-layer chromatography in forensic chemistry and analysis of unknown materials.
- Interpret R_f values and retention times in chromatograms to determine the composition of a mixture.
- Explain the importance of selecting the appropriate stationary and mobile phases in chromatography and their impact on the separation of compounds.
- Describe the use of mass spectrometry in combination with chromatography for identifying and quantifying small amounts of unknown materials in forensic analysis.

28.1 INTRODUCTION

Separating one or two components from a simple mixture needs simple techniques such as filtration, distillation, and solvent extraction. However, complex mixtures require advanced techniques. Chromatography is a versatile and important analytical technique that allows chemists to separate the individual components of a complex mixture based on their varying affinities for two different phases. Complex mixtures, such as dyes in blooming flowers, pollutants in a water body, or medicinal extracts from the plant leaves, can be separated using chromatography. Use of chromatography allows for the identification, purification, and quantification of substances with high precision, making chromatography an efficient modern chemical analytical tool in medicine, forensic, environmental science, etc.

Adsorption is a surface phenomenon in which particles accumulate only on the outer surface. For example, activated charcoal adsorbs gases and impurities onto its surface, which is why it's used in filters and purification systems. Among many types of chromatography, the three important types are:

- Paper chromatography (PC)
- Thin layer chromatography (TLC)
- Gas chromatography (GC)

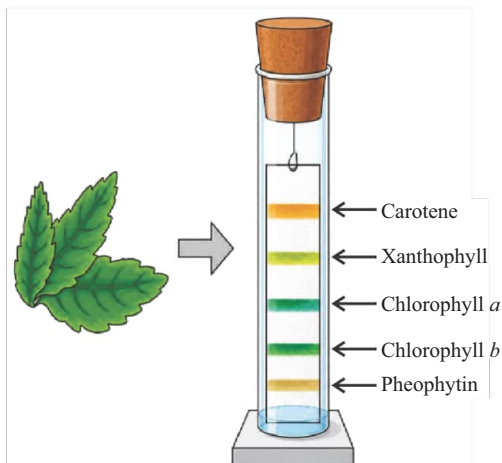


Figure 28.1 The complex mixture of pigments in leaf can be efficiently separated using chromatography



28.2 PAPER CHROMATOGRAPHY

The technique of using a solvent to separate a mixture into its components is called paper chromatography. The separating principle depends on relative solubility of the components. The piece of paper used in chromatography contains water combined with cellulose of the paper. A small spot of the sample is put on the base line near the bottom of the paper by capillary tube. The paper is dipped in a suitable solvent which will soak up the paper. The solvent level must be below the spot of the sample. The solutes present in the sample dissolve in the solvent to different extents. Some are more soluble in the solvent (mobile phase) moving up the paper. Others dissolve better in the water trapped in the paper (stationary phase); therefore, they do not travel very far up the paper. This difference in the solubility allows the different components in the sample to be separated.

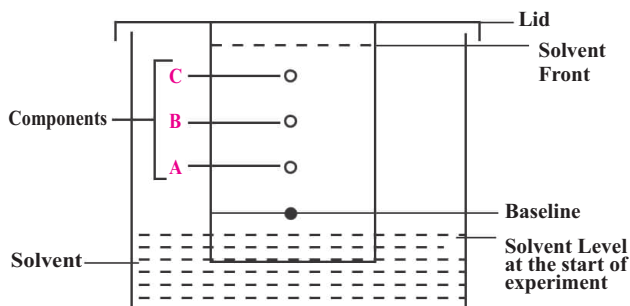


Figure 28.2 Paper Chromatography

Chromatography is used to separate both coloured and colourless substances. Colourless substances can be visualised by spraying them with a locating agent which give colour to them.

The R_f value (Retardation factor or Retention factor) of a substance is calculated by dividing the distance traveled by the component with the distance travelled by the solvent.

$$R_f = \frac{\text{Distance traveled by the substance}}{\text{Distance traveled by the solvent}}$$

R_f has no unit because it is ratio. The R_f value of a substance does not change under same conditions (same solvent and same temperature). One advantage of using chromatography is that it consumes very small quantity of the mixture.

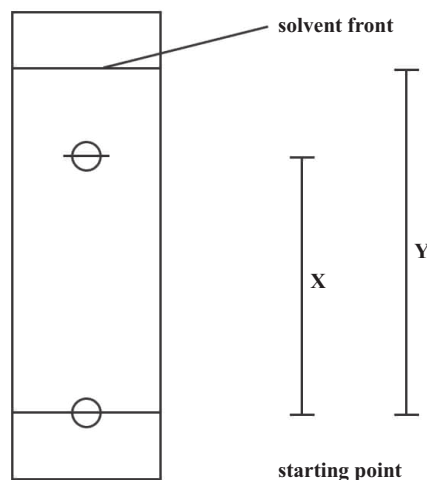


Figure 28.3 Measuring distance of spot and solvent front

28.3 THIN-LAYER CHROMATOGRAPHY

In thin layer chromatography (TLC), alumina (Al_2O_3) or silica (SiO_2) is mixed in water to make slurry which is then spread evenly onto a glass slide. This layer is dried in an oven to make a white solid layer (stationary phase) on the glass slide. TLC is faster than paper chromatography.

A straight baseline is drawn by pencil and ruler near the bottom of the glass slide. A spot of sample



is put on the baseline by the capillary tube. More than one samples can be spotted at different places on the same glass slide. The solvent is taken in a chromatography tank. The glass slide is dipped in the solvent (mobile phase) in such a way that baseline is above solvent level.

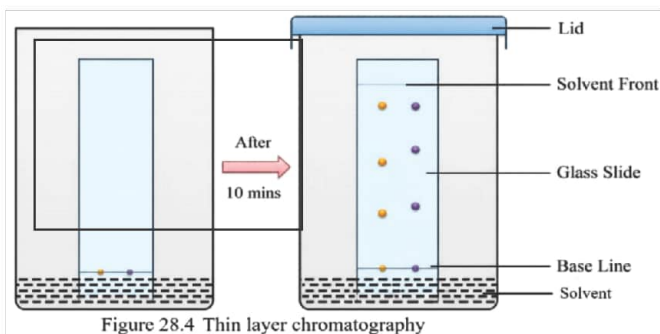


Figure 28.4 Thin layer chromatography

The components present in the sample dissolve in the solvent and

adsorb onto aluminium oxide differently. Some are more soluble in the mobile phase while some are more adsorbed onto the solid stationary phase. Polar substances have greater attraction for polar solid stationary phase and are adsorbed more strongly. Therefore, they travel more slowly up the stationary phase. On the other hand, non-polar substances are more soluble in the non-polar solvent, and they move more up the slide. This difference allows the substances in the sample to separate. After the solvent has moved up to a certain height, the glass slide is removed from the chromatographic chamber. Solvent front, the highest point reached by the solvent, is marked. The glass slide is dried by dryer. R_f values of different coloured spots are calculated.

By comparing these R_f values with standard values, the components present in the sample are identified. Sometime the components are colourless, locating agent is sprayed to visualise them. Ninhydrin spray give purple colour to colourless amino acids. Some colourless substances glow when irradiated with ultra-violet light while some turn brown with iodine vapours.

Applications:

- i) TLC identify unknown compounds by comparing their R_f values with standard known values.
- ii) The purity of a substance can be checked by TLC.
- iii) The progress of reaction whether reactants are consumed or products are made, can be checked by TLC.
- iv) In pharmaceutical and food industry, purity of drugs and presence of preservatives, colourants, sweeteners in food can be checked by TLC.
- v) TCL can also detect pollutants, pesticides, toxic substances in soil, water, food and air.
- vi) TLC is useful in forensic science where it is used to identify drugs, post blast debris, blood, sweat, semen at crime scene.

Limitations:

- i) TLC is mainly a qualitative technique and can only give an idea about the amount of a substance. So, TLC is not accurate and precise quantitative technique.
- ii) TLC cannot clearly separate compounds having close R_f values. Hence resolution of spots is not always high and sharp.



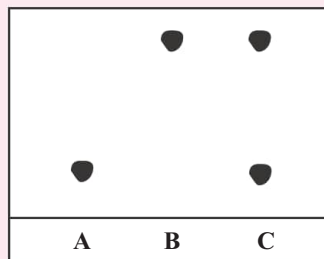
- iii) In TLC, only small amounts of sample can be applied and analysed. It is not suitable for large-scale separation.
- iv) This technique is sensitive to humidity, temperature and cleanliness of working environment which reduces reproducibility.



Quick Check 28.1



- a) A mixture contains butanone and pentane. How can they be separated by using thin layer chromatography using aluminium oxide as stationary phase and benzene as solvent?
- b) A mixture of two substances X and Y is analysed by thin-layer chromatography. The R_f value of substance X is larger than that of substance Y. Suggest why substance X has a larger R_f value.
- c) A separate thin layer chromatography experiment was done using the hair dyes A, B and C. The chromatogram obtained is shown. State three conclusions about the hair dyes A, B and C which can be deduced from the chromatogram.



28.4 GAS CHROMATOGRAPHY

Gas chromatography (GC) is used to separate gases, volatile liquids and solids (in gaseous form). In GC, the stationary phase is a non-volatile, long chain, non-polar hydrocarbon liquid having high boiling point bonded to small particles of silica (SiO_2) or alumina (Al_2O_3). In GC, the mobile phase is an inert gas (carrier gas) such as helium or nitrogen. The sample is injected into injector port, where sample is quickly vapourised by an oven. The carrier gas carries the vapours of the sample through a long-coiled column packed with tiny silica particles having large surface area over which separation occurs.

The non-polar substances in the mixture have greater interaction with non-polar liquid on the solid particles of stationary phase. Therefore, these non-polar substances are carried through the column more slowly. Thus, substances that interact more strongly move slower while other move faster, resulting in separation. As the separated substances exit the column, they pass through a

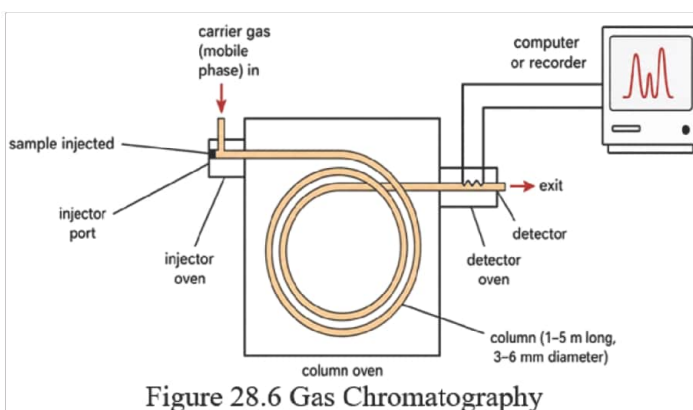


Figure 28.6 Gas Chromatography

Figure 28.5 Gas chromatography

detector which identify and record them as peaks on a graph called a chromatogram. Detector



also records retention time of each component. The time taken by a substance to pass through the column is retention time.

Gas chromatography has high sensitivity, good resolution, fast analysis and accurate quantification. Mixture of gases can easily be separated by GC at room temperature. GC is also a quantitative technique. The peaks obtained are first identified and then area of each peak is measured which will give the proportion of each component in the mixture. The peaks are similar to triangles, therefore, the area of peak can be calculated by the following formula.

$$\text{Area of a peak} = \frac{1}{2} \times \text{base} \times \text{height}$$

The percentage of an ester A in the mixture of three esters A, B and C is given by,

$$\% \text{ of A} = \frac{\text{peak area of A}}{\text{sum of peak areas of A, B and C}} \times 100$$

If the peaks are very narrow or have similar base widths then peak height is used instead of area to estimate the proportion of components in a mixture. GC is used to check the presence of steroids in competing athletes. This is also used to test the components of fuel used in car racing.

Applications:

- i) In the industrial sector, GC is vital for quality control and environmental protection. For example, Petrochemical plants use it to analyse the composition of fuels, and for detecting trace amounts of organic pollutants in environmental samples.
- ii) Forensic laboratories rely heavily on gas chromatography to provide evidence in legal investigations. It is frequently used to perform blood alcohol content (BAC) tests. Additionally, GC is used to detect illegal drugs, poisons, or performance enhancing substances in biological samples.
- iii) The food and beverage industry utilises GC to ensure the consistency and safety of products. It can detect spoilage by identifying metabolic byproducts of bacteria or fungi before they are visible to the eye. Furthermore, GC is used to analyse the complex aromatic profiles of perfumes, essential oils, and food flavourings.
- iv) In clinical settings, gas chromatography is used to diagnose metabolic disorders by analysing specific compounds in a patient's breath or urine. It also plays a role in pharmaceutical research, where it is used to test the purity of newly synthesized drugs, ensuring that no harmful residual solvents or impurities remain in the final medication before it reaches the patient.

MORE INFO

Interesting Information

Chromatography is important in forensic science. A man in China, namely Nian Bin, was accused of murdering two neighbouring children by mixing rat poison (a fluoroacetate) in their food in 2005. However, after 8 years, in 2013, he was proven innocent and released. The food sample was tested using gas chromatography, which proved no mixing of the poison.



Limitations:

- GC works only for volatile (easily vaporised) substances.
- Samples must be thermally stable. Compounds that decompose at high temperatures cannot be used.
- Large biomolecules like proteins and polymers cannot be analysed by GC because they do not vaporise easily.
- Instruments and maintenance costs for GC are high.

**Quick Check 28.2**

An impure sample of lactic acid, $\text{CH}_3\text{CH}(\text{OH})\text{COOH}$ contains butanone as the only contamination. The mixture is analysed using gas chromatography. Butanone is found to have a longer retention time than lactic acid.

- Suggest suitable substances that could be used as the mobile and stationary phases.
- Describe how the percentage composition of the mixture can be determined from the gas chromatogram.

28.5 Comparison of three types of chromatography

Feature	Paper Chromatography	TLC (Thin-Layer)	GC (Gas Chromatography)
Principle	Partition	Adsorption + solubility	Partition (gas-liquid)
Mobile Phase	Liquid	Liquid	Gas
Stationary Phase	Water in paper	Silica/alumina	Non-volatile liquid
Speed	Slow	Faster	Very fast

Exercise

Q1. MULTIPLE CHOICE QUESTIONS:

- I) Why must the solvent level be below the spot of the dye?
- To increase temperature
 - To prevent the dye from dissolving directly into the solvent
 - To speed up chromatography
 - To increase adsorption
- II) Why do some components of a dye travel further up the paper than others?
- They are more soluble in the water trap in paper (stationary phase)
 - They are more soluble in the solvent (mobile phase)
 - They react with the paper
 - They have higher density



III) A substance has a very low R_f value. What does this indicate?

- a) It is insoluble in the solvent
 b) It is highly soluble in the solvent
 c) It strongly sticks to the water inside paper
 d) It has a high density

IV) Which statement best explains adsorption?

- a) Substance dissolves completely in another
 b) Substance sticks only to the surface of another material
 c) Substance changes its state
 d) Substance reacts chemically

V) A polar compound in TLC will usually:

- a) Travel farther up the plate
 b) Stay near the baseline
 c) Evaporate quickly
 d) Dissolve completely

VI) Why is TLC considered faster than paper chromatography?

- a) It uses more solvent
 b) It has a solid stationary phase that allows quicker separation
 c) It requires higher temperature
 d) It uses colored substances only

VII) What is the role of the carrier gas in gas chromatography?

- a) To react with the sample
 b) To act as stationary phase
 c) To carry vaporized sample through the column
 d) To detect the substances

VIII) Why must the stationary phase in GC have a high boiling point?

- a) To evaporate quickly
 b) To increase pressure
 c) To remain in liquid form during the process
 d) To react with gases

IX) What does the area under a peak in a chromatogram indicate?

- a) Amount (proportion) of the substance
 b) Retention time
 c) Temperature of column
 d) Color of compound

X) If two peaks have similar base width but different heights, how can composition be estimated?

- a) By color
 b) By retention time
 c) By pressure
 d) By peak height

Q2. SHORT ANSWER QUESTION:

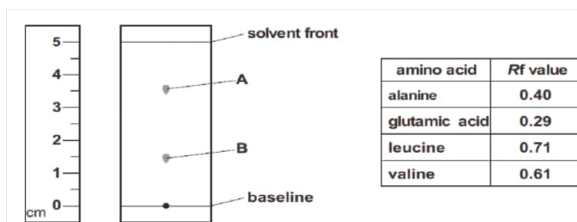
- What is the principle of paper chromatography?
- Why is pencil used instead of ink in chromatography to mark the baseline?
- State two advantages of TLC over paper chromatography.
- Why do polar substances move slowly in TLC?
- Why is TLC not suitable for large-scale separation?
- What is the function of injector port in GC?
- Why must samples be volatile in GC?
- State two limitations of gas chromatography.
- What information does a chromatogram provide?



j) What is adsorption? Give one example.

Q3. CONSTRUCTED RESPONSE QUESTIONS

a) A mixture of amino acids is analysed using thin layer chromatography. The chromatogram obtained is shown. The table shows some R_f values for different amino acids in the same solvent.

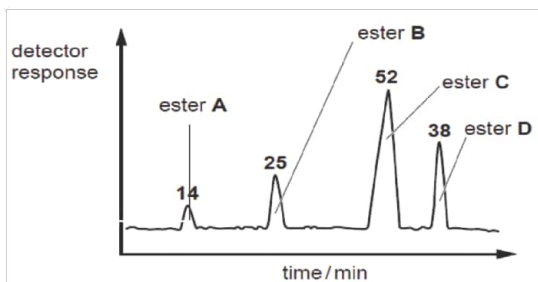


- i) Use the chromatogram and the R_f values to deduce the amino acid responsible for spot A and spot B.
- ii) A second chromatogram of the same mixture is taken using a more polar solvent. Predict the effect on the R_f values of the amino acids. Explain your reasoning.

3. Gas chromatography involves a stationary phase and a mobile phase.

a) Name a suitable substance that could be used for each phase.

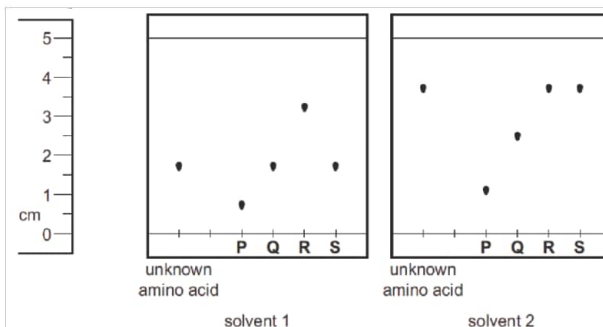
b) A mixture of three organic compounds is separated by gas chromatography. The chromatogram obtained is shown below.



i) Explain the meaning of the term retention time.

ii) Calculate the % of N in the mixture. Show your working.

c) An unknown amino acid is analysed by thin-layer chromatography. Two chromatographs of the unknown amino acid and four reference amino acids, P, Q, R and S, are obtained using two different solvents. Identify the unknown amino acid. Justify your answer.



DESCRIPTIVE QUESTIONS

Q4. Describe the principle and working of paper chromatography.

Q5. Explain the principle and working process of thin layer chromatography (TLC) in detail.

Q6. Describe the main components of gas chromatography.



29

SPECTROSCOPY-1

Student Learning Outcomes

[C-12-E-03 to C-12-E-18]

- ⊙ Explain that the degree of unsaturation or index of hydrogen deficiency (IHD) can be used to determine from a molecular formula, the number of rings or multiple bonds in a molecule.
- ⊙ Explore how Mass spectrometry (MS), proton nuclear magnetic resonance spectroscopy (^1H NMR), infrared spectroscopy (IR) are techniques that can be used to help identify compounds and to determine their structure.
- ⊙ Interpret an infrared (spectrum of a simple molecule to identify functional groups).
- ⊙ Deduce possible structures for organic compounds using IR spectrum and molecular formula (Examples: phenol, acetone, ethanol).
- ⊙ Predict whether a given molecule will absorb in the UV/visible region.
- ⊙ Predict the colour of a transition metal complex from its UV/visible spectrum.
- ⊙ Explain atomic emission and atomic absorption spectrum.
- ⊙ Explain how a mass spectrometer can be used to determine the relative atomic mass of an element from its isotopic composition.
- ⊙ Perform calculations involving non-integer relative atomic masses and abundance of isotopes from given data, including mass spectra.
- ⊙ Explain the concept of emission spectra. Use the concept of emission spectra to deduce the electronic configuration of elements.
- ⊙ Analyze mass spectra in terms of m/e values and isotopic abundances (knowledge of the working of the mass spectrometer is not required).
- ⊙ Calculate the relative atomic mass of an element given the relative abundances of its isotopes, or its mass spectrum.
- ⊙ Deduce the molecular mass of an organic molecule from the molecular ion peak in a mass spectrum.
- ⊙ Suggest the identity of molecules formed by simple fragmentation in a given mass spectrum.
- ⊙ Deduce the number of carbon atoms, n , in a compound using the M^+ peak and the formula $n = 1.1 \times$ abundance of M^+ .
- ⊙ Deduce the presence of bromine and chlorine atoms in a compound using the M peak.

Light and other forms of electromagnetic radiation travel in the form of waves, which consist of oscillating electric and magnetic fields. These waves are defined by their wavelength (λ) and frequency (ν), and they travel at the speed of light ($c = 3.0 \times 10^8 \text{ m/s}$). The relationship between these is given by:

$$c = \lambda \nu$$

where λ is the wavelength (in meters), ν is the frequency (in Hertz or s^{-1}), and c is the speed of light (in ms^{-1}).



The electromagnetic spectrum comprises of different radiations, including radio waves, microwaves, infrared radiation, visible light, ultraviolet radiation, X-rays, and gamma rays.

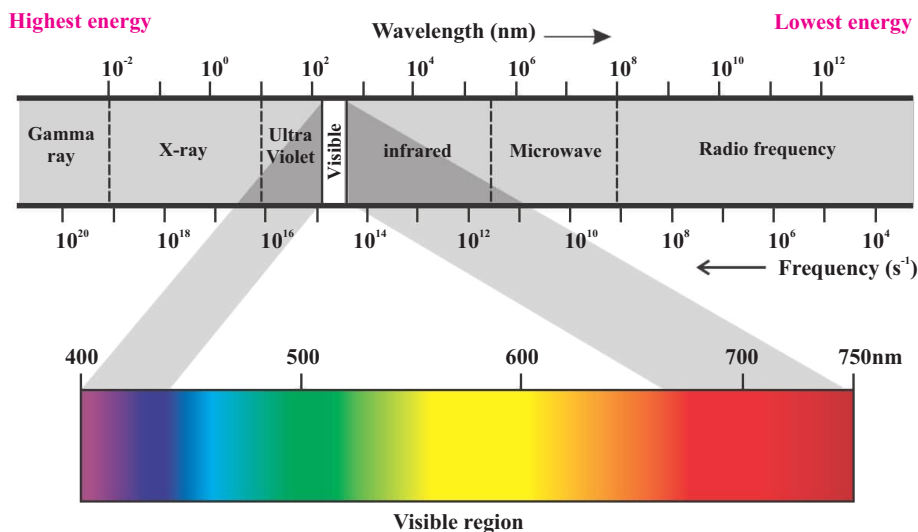


Figure 29.1 Electromagnetic spectrum showing wavelength, frequency, energy, and the visible light region.

According to Planck's quantum theory

1. Only discrete amounts of energy may be emitted or absorbed by various atoms and molecules. Quantum energy is the smallest quantity of electromagnetic radiation that can be released or absorbed.
2. The frequency of a radiation and the energy it carries are directly proportional to each other. The energy of radiation is expressed as,
Where,

E = Energy of the radiation

h = Planck's constant (6.626×10^{-34} J.s)

ν = Frequency of radiation

$$E = \frac{hc}{\lambda} \quad \text{J} \longrightarrow E = hc\nu \longrightarrow \text{cm}^{-1}$$

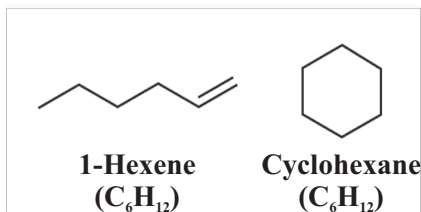
$\frac{\text{J.s}}{\text{m}} \times \frac{\text{m}}{\text{s}}$
 $\frac{\text{m}}{\text{s}}$

29.1 INDEX OF HYDROGEN DEFICIENCY (IHD)

Consider the given compounds shown here.

These compounds have the same molecular formula but different structures, i.e. these are two isomers. However, there is one more similarity between these two compounds. Both these have two hydrogens less than a saturated alkane. It means they have a deficiency of two hydrogen atoms.

The deficiency of hydrogen corresponds to the degree of unsaturation of a compound. The index of hydrogen deficiency (IHD) is a measure of the **degrees of unsaturation** in a compound. A compound is said to have one degree of unsaturation for every two hydrogen atoms that are missing.



This is why the above two compounds have an IHD equal to 1. The degree of unsaturation (U), or index of hydrogen deficiency (IHD), is defined as the difference in the number of pairs of hydrogen atoms between the compound and the acyclic alkane with the same number of carbon atoms. Each double bond or ring costs two hydrogen atoms compared to a saturated analog and results in one degree of unsaturation. For example, if a compound has the molecular formula C_4H_6 , it has four hydrogen atoms less than the saturated, compound C_4H_{10} . Therefore, this compound has two degrees of unsaturation (IHD=2).

Importance of IHD

Knowing the IHD of a molecule gives clues about its composition and structure. For example, if the IHD is 0, it is certain that the chemical has no rings and no double bonds. This is very helpful because you can find this number easily just by looking at the chemical formula.

If the IHD is 1, the chemical must have either **one ring or one double bond**, but it cannot have both. If the IHD is 2, there are a few choices: it could have two rings, two double bonds, one of each, or one triple bond. Thus, IHD can give us very useful information about a chemical without using complex analytical techniques. Also, before using an analytical technique IHD will help to assess which technique would be better for the compound under study. The IHD for hydrocarbons can be calculated using the data given in **Table 29.1**.

Keep in Mind

A double bond and ring each counts as one IHD. A triple bond counts as two IHD.

Table 29.1 Index of hydrogen deficiency

Formula	Index of Hydrogen Deficiency (IHD)	Structure Unit Involved
C_nH_{2n+2}	0	open chain alkane only
C_nH_{2n}	1	1 double bond or 1 ring
C_nH_{2n-2}	2	2 double bonds or 2 rings or 1 double bond plus 1 ring or 1 triple bond



Quick Check 29.1



- a) Calculate the IHD for each of the following.
 - i) C_6H_6
 - ii) C_6H_{12}
 - iii) C_4H_4
- b) Propose the structure of the above compounds.
- c) Hopanes are the waxy solids found in petroleum products as residues after refining the crude oil. A hopane has the formula $C_{30}H_{62}$.
 - i) Find its IHD.
 - ii) Predict whether this compound is saturated or not.



29.2 ATOMIC SPECTRUM

Atomic spectra are observed when atoms emit or absorb light of a certain wavelength, known as emission spectra and absorption spectra respectively. Atomic spectra provide evidence that electrons in atoms can only transition between discrete atomic energy levels. When energy is absorbed by electrons of an atom, electrons move from lower energy levels to higher energy levels. These excited electrons radiate energy to return from the excited state to ground states and form emission spectra.

Emission spectra can be produced by heating a low-pressure gas. Heating provides energy to excite electrons to higher energy levels.

When an electron transitions back to a lower energy level, it emits a photon. Each transition corresponds to a specific wavelength of light which appears as an observable spectral line. The resulting emission spectrum contains a set of distinct wavelengths, represented by coloured lines on a black background.

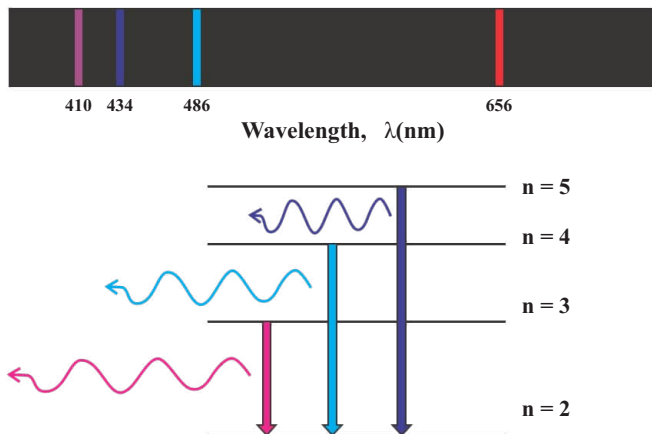


Figure 29.2 Hydrogen emission spectrum

On the other hand, an absorption spectrum contains the frequencies of light transmitted in the form of dark bands when energy is absorbed by the electrons in the ground state to reach higher energy states. Absorption spectra can be produced by passing white light through a cool, low-pressure gas. Only photons with the exact energy required to excite electrons will be absorbed. Each absorbed photon corresponds to a specific wavelength of light which appears as a dark line on a coloured background.

These lines correspond to the same lines observed on an emission spectrum for the same element. An absorption spectrum is like a photographic negative of an emission spectrum.

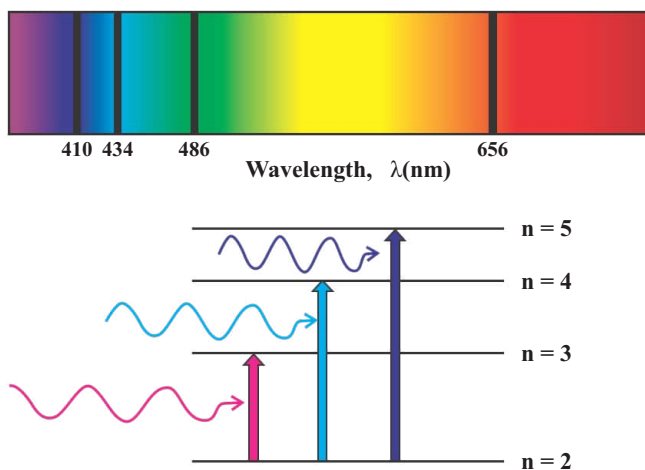


Figure 29.3 Hydrogen absorption spectrum



29.3 SPECTROSCOPY

Spectroscopy deals with the production, measurement, and interpretation of spectra arising from the **interaction of electromagnetic radiation with matter**. A spectrum can be used to obtain information about atomic and molecular energy levels, molecular geometries, interactions of molecules and the nature of chemical bonds. A spectroscopic measurement can also be used for measuring the amount of a specific substance in a sample (quantitative analysis) or even just to identify an unknown sample (qualitative analysis).

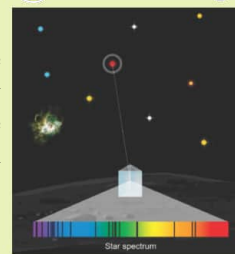
The **chemical composition** of a substance can be investigated using emission and absorption spectra. Each element produces a unique pattern of spectral lines. No two elements produce the same set of spectral lines, therefore, elements can be identified by their atomic spectra. Emission line spectra are unique to each element, like a fingerprint.

For example, hydrogen is known to produce strong spectral lines in the red portion of the visible spectrum, at 656 nm. When sodium is burned, a characteristic yellow flame is observed due to the strong spectral lines in the yellow portion of the spectrum, at 589 nm. When mercury is burned, most of the emission lines are below 450 nm, which produce a characteristic blue light.



Did You Know?

Atomic spectra can also help astronomers to determine the chemical composition of stars. By analyzing the light emitted from these celestial bodies, scientists can uncover the mysteries of the universe.



29.4 UV/VISIBLE SPECTROSCOPY

Ultraviolet-visible (UV-Vis) spectroscopy is one of the most popular analytical techniques because it is very versatile and easy to use. In UV-Vis spectroscopy, the UV-Vis light is passed through a sample and the transmittance of light is measured. The absorbance (A) can be determined from the transmittance (T) using the formula $A = -\log(T)$. A UV-Vis spectrum displays the absorbance of a substance at various wavelengths. The amount of absorbance at any wavelength is due to the electronic structure of the molecule.

Types of electrons in a compound can be:

- 1. σ electrons (σ -bonds)
- 2. π electrons (in unsaturated compounds only)
- 3. n electrons (non-bonded electrons)

Sigma bonding orbitals are lower in energy than π bonding orbitals, which in turn, are lower in energy than non-bonding orbitals. When electromagnetic radiation of the correct frequency is absorbed, a transition occurs from one of these orbitals (π or n) to an empty orbital, usually an antibonding orbital, σ^* or π^* . UV-Vis spectroscopy uses the wavelengths from 200-800 nm to study the changes in electronic energy levels. These changes are due to the transfer of electrons from π - or non-bonding orbitals as shown in **Figure 29.4**.



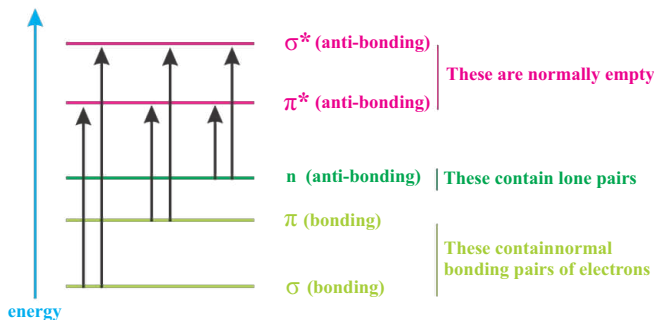


Figure 29.4 Transition of electrons from lower energy to higher energy levels

In each possible case, an electron is excited from a filled orbital into an empty anti-bonding orbital. Each jump takes energy from the light of a specific wavelength will be absorbed. The important electronic transitions are:

- from pi bonding orbitals to pi anti-bonding orbitals (π to π^*)
- from non-bonding orbitals to pi anti-bonding orbitals (n to π^*)
- from non-bonding orbitals to sigma anti-bonding orbitals (n to σ^*)

The diagram below shows a simple UV-visible absorption spectrum for buta-1,3-diene, $\text{CH}_2=\text{CH}-\text{CH}=\text{CH}_2$. Absorption peaks at a value of 217 nm corresponds to the wavelength absorbed maximum and is called λ_{max} . This is in the UV region and so there would be no visible sign of any light being absorbed the compound is colourless. There are no non-bonding electrons so the only electron jumps taking place (within the range that the spectrometer can measure) are from pi bonding to pi anti-bonding orbitals.

The value of λ_{max} for a particular compound is highly dependent on the extent of conjugation. To illustrate this point, compare the MOs of butadiene, hexatriene, and octatetraene.

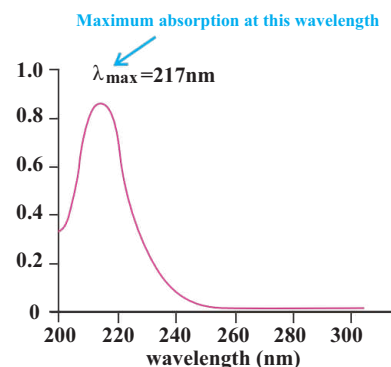
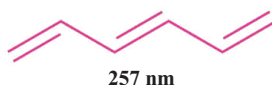
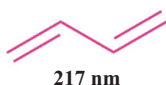


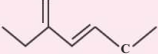


Figure 29.5 Absorption spectrum



In a conjugated system, atoms share electrons across a long chain. The more "conjugated" a compound is, the more energy levels it has, and the gaps between those levels become smaller. Because these gaps are smaller, it takes less energy to push an electron from a low level to a higher one. Since the energy of light depends on its frequency, these smaller energy gaps allow the compound to absorb light with less energy (lower frequency), which is why highly conjugated compounds often have bright colours. Because longer light waves have less energy, these chemicals absorb light with a longer wavelength, called the λ_{max} . This means that the more double bonds a compound has connected together, the higher its λ_{max} number will be. Usually, every time you add one more double bond to the chain, that number increases by about 30 to 40 nm. By looking at this number, the extent of conjugation in a compound can be determined.




Quick Check 29.2

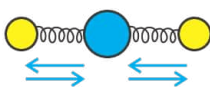
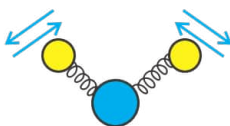
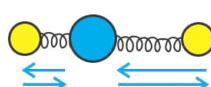
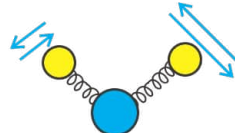

- a) Which type of electronic transitions require least energy in UV/Vis spectroscopy? Explain.
 i) $\sigma \rightarrow \sigma^*$ ii) $\pi \rightarrow \pi^*$ iii) $n \rightarrow \sigma^*$ iv) $n \rightarrow \pi^*$
- b) Arrange the following in an increasing order of λ_{\max}
- i)  ii)  iii) 
- c) Will $\text{CH}_3\text{CHOHCH}_3$ show a significant absorption in the UV-Vis region.


MORE INFO Interesting Information

An Interesting InfoGreen tomato and a red ripen tomato both have different colours. Green tomato has chlorophyll in higher quantities, while red tomato contains lycopene. Both these compounds have different λ_{\max} and a specific colour in the visible range.

29.5 INFRARED SPECTROSCOPY

All covalent bonds act rather like springs, the bonds can vibrate in a number of different ways. The frequencies of vibrations occur in the infra-red region of the electromagnetic spectrum. If an organic molecule is irradiated with the infra-red energy that matches the natural vibration frequency of its bonds, it absorbs some of that energy and the amplitude of vibration increases.

Symmetric Stretching

Symmetric Bending

Asymmetric Stretching

Asymmetric Bending

Figure 29.6 Different modes of vibration in molecules

Infrared (IR) spectroscopy is a technique used to identify compounds which is based on changes in vibrations of atoms when they absorb IR of specific frequencies. A spectrophotometer irradiates the sample with IR radiation and then detects the absorption of radiation by the molecule. IR energy is absorbed only if a molecule has a permanent dipole that changes as it vibrates. Symmetrical and nonpolar molecules such as O_2 or H_2 , are, therefore, IR inactive. Polar bonds such as O-H, N-H, etc. show absorption at higher wavenumbers. Similarly, bonds with smaller bond length and those with multiple bonds (e.g., $\text{HC}\equiv\text{CH}$) also absorb at higher wavenumbers. The reason for these observations is that these bonds are stronger and require higher energy. An IR spectrum consists of two regions. The fingerprint region below 1500 cm^{-1} and the functional group region above 1500 cm^{-1} . Only functional region is discussed here which is enough to interpret the nature of organic compound.

The table below gives information about infrared absorption frequencies (wave numbers).

Table 29.2 IR Absorption ranges of functional groups (cm^{-1})

Bond	Functional groups containing the bond	Characteristic infrared absorption range (in wavenumbers)/ cm^{-1}
C—O	Alcoholic, ester	1040–1300


Did You Know?

Infrared spectroscopy can be used to measure alcohol levels using modern roadside breathalyser. A ray of infrared radiation is passed through the breath that is exhaled into the breathalyser chamber. The characteristic bonds of ethanol are detected and measured - the higher the absorbance of infrared radiation, the more ethanol in the person's breathe.



C=C	aromatic compound, alkene	1500–1680
C=O	amide carbonyl, carboxyl ester	1640–1690 1670–1740 1710–1750
C≡N	nitrile	2200–2250
C–H	alkane	2850–2950
N–H	amine, amide	3300–3500
O–H	carboxyl hydroxy	2500–3300 3200–3600

29.5.1 Interpreting and Predicting Infrared Spectra

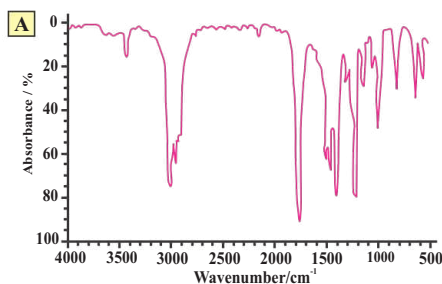
The best way to understand how to interpret an IR spectrum is by looking at solved examples and becoming familiar with the characteristic features of an IR spectrum.

Example 29.1

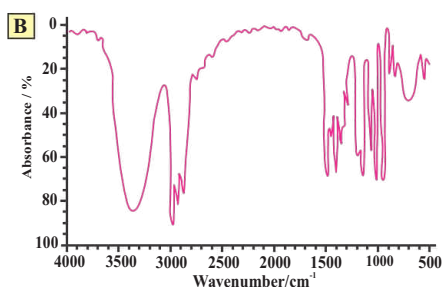
Examine the two spectra shown and determine which one belongs to propan-2-ol and which one belongs to propanone.

Answer

The presence of a strong, sharp absorption around 1710 cm^{-1} corresponds to the characteristic C=O, carbonyl, the functional group in a ketone. IR spectrum A is propanone.

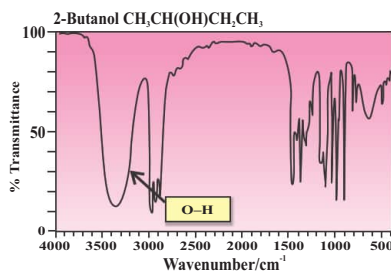


In spectrum B the presence of a strong, absorption around $3200\text{--}3600\text{ cm}^{-1}$ suggests that there is an alcohol group present, which corresponds to the -OH group in propan-2-ol.

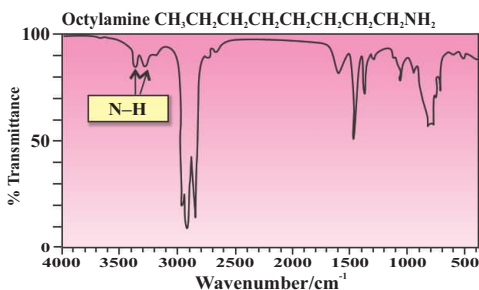


29.5.2 IR Spectra of Important Functional Groups

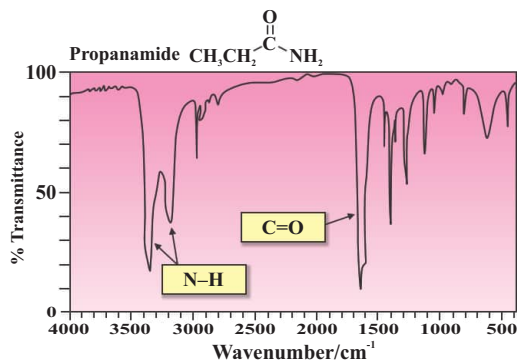
The OH group of the alcohol shows a strong absorption at $3600\text{--}3200\text{ cm}^{-1}$. The peak at 3000 cm^{-1} is due to sp^3 hybridized C–H bonds.



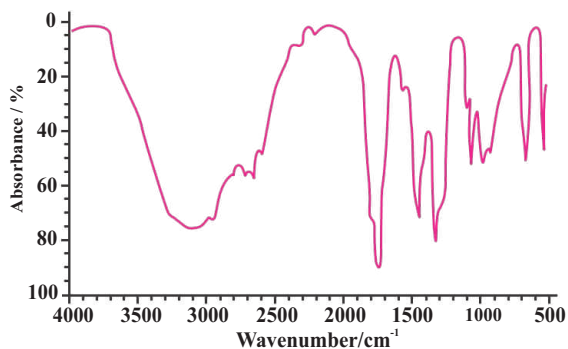
The N–H bond in an amine gives rise to two weak absorptions at 3300 and 3400 cm^{-1} .



An amide exhibits absorptions above 1500 cm^{-1} for both its N–H and C=O groups: N–H (two peaks) at 3200 and 3400 cm^{-1} ; C=O at 1660 cm^{-1} .



The C=O group in the carboxylic acids shows a strong absorption at 1700 cm^{-1} along with broad and deep absorption of the O–H bond of a carboxylic acid between 2500 and 3300 cm^{-1} . The broad peak caused by the O–H bond of a carboxylic acid between 2500 and 3300 cm^{-1} . This right hand side of this peak is often distorted by the peaks from C–H bonds.



NOTE: N–H signal in amines is broad but it is not broader than O–H signal in alcohols.



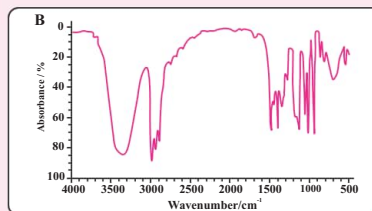
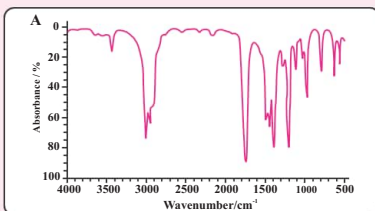
Did You Know?

Infrared spectroscopy is used to identify pollutants in vehicle emissions. The air sensors detect and measure the amount of pollutants such as carbon monoxide, carbon dioxide and unburnt hydrocarbons. This commonly occurs on motorways and in busy town centres to monitor localised pollution.

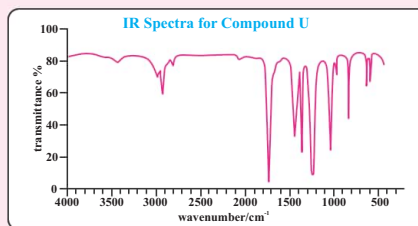
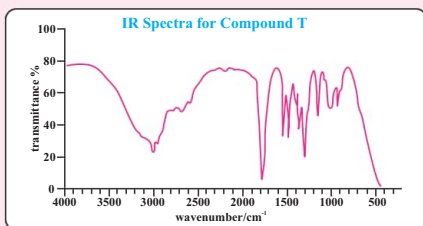


Quick Check 29.2

I. Which one of the infra-red spectra is that of butanone and which one is of butan-2-ol?



- ii. Compounds T and U are isomers with the molecular formula $C_3H_6O_2$. Suggest their structures based on the spectra shown below:

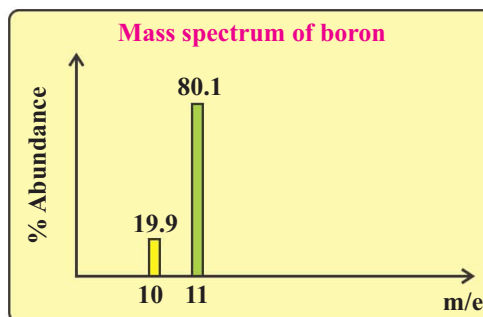


29.6 MASS SPECTROMETRY

Mass spectrometry is an analytical technique used to identify unknown compounds. The molecules/atoms in the small sample are bombarded with high energy electrons which can cause a molecule/atom to lose an electron. As a result, a positive ion is formed which is detected by detector and recorded as m/e (mass to charge ratio of the ion) versus percentage of ion.

29.6.1 Isotopic Mass and Abundance

Mass spectrometry can be used to find the relative abundance of the isotopes experimentally. The relative abundance is the proportion of a particular isotope in a mixture of isotopes found in nature. For example, the relative abundance of Cl-35 and Cl-37 is 75% and 25% respectively. The heights of the peaks in mass spectroscopy show the proportion of each isotope present. For example, in the graph below, the peak heights show the relative abundance of the boron isotopes: boron-10 has a relative abundance of 19.9% and boron-11 has a relative abundance of 80.1%.



Calculating Relative Atomic Mass

The mass of an element is given as relative atomic mass, A_r , by using the average mass of the isotopes. The relative atomic mass of an element can be calculated by using the relative abundance and isotopic masses. The relative abundance of an isotope is either given or can be read the mass spectrum.

$$\text{Relative Atomic Mass } (A_r) = \frac{\sum (\text{isotopic mass} \times \text{isotopic abundance})}{100}$$

Example 29.2

Calculate the relative atomic mass, A_r , of oxygen to 2 decimal point.

Answer

$$A_r = \frac{(99.76 \times 16) + (0.04 \times 17) + (0.20 \times 18)}{100}$$

$$A_r = 16.0044$$

$$A_r = \mathbf{16.00} \text{ (to 2 d.p.)}$$

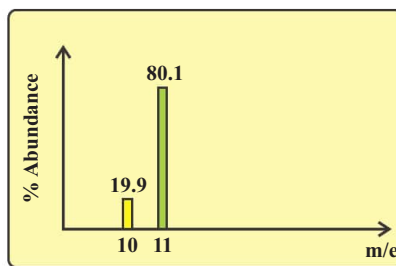
Isotope	Percentage abundance
^{16}O	99.76
^{17}O	0.04
^{18}O	0.20



Example 29.3

Calculate the relative atomic mass of boron using its mass spectrum, to 2 decimal point.

- $A_r = \frac{(19.9 \times 10) + (80.1 \times 11)}{100}$
- $A_r = 10.801$
- $A_r = \mathbf{10.80}$ (to 2 decimal point)

**29.6.2 Molecular Ion Peak and Fragmentation**

When molecules in a sample compound are bombarded with highly accelerated electrons it causes the molecules to lose electrons. This results in the formation of a positively charged molecular ion with one unpaired electron. One of the electrons in the pair has been removed by the beam of electrons.



Molecule^{+•} represents the molecular ion. The molecular ion can further fragment to form new ions, molecules, and free radicals.

a) Deducing Molecular Formula

Each peak in the mass spectrum corresponds to a certain fragment with a particular m/e value. The peak mostly with the highest m/e value is the molecular ion (M⁺) peak which gives information about the molecular mass of the compound. **The molecular ion is the entire molecule that has lost one electron when bombarded with a beam of electrons.**

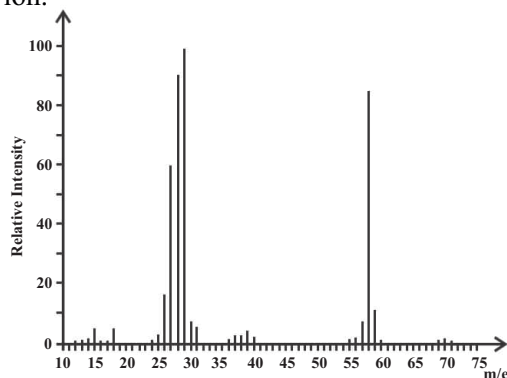


The [M+1] peak is a smaller peak which is due to the natural abundance of the isotope carbon-13. The height of the [M+1] peak for a particular ion depends on how many carbon atoms are present in that molecule; the more carbon atoms, the larger the [M+1] peak is. For example, the height of the [M+1] peak for hexane (containing six carbon atoms) ion will be greater than the height of the [M+1] peak of ethane (containing two carbon atoms) ion.

Example 29.4

Determine whether the following mass spectrum corresponds to propanal, CH₃CH₂CHO or butanal, CH₃CH₂CH₂CHO.

Answer: The mass spectrum corresponds to propanal as the molecular ion peak is at m/e = 58. The molecular ion mass of CH₃CH₂CHO⁺ ion is 58 and butanal arises from the CH₃CH₂CH₂CHO⁺ ion which has a m/e of 72.



b) Identifying Molecules Using Fragmentation

The molecular ion peak can be used to identify a compound by its molecular mass. However, different compounds may have the same molecular mass. To further determine the structure of the unknown compound, fragmentation is used. Fragments may appear due to the formation of characteristic smaller ions or the loss of small molecules. For example, loss of small molecules/fragments give rise to peaks at 18 (H_2O), 29 (C_2H_5^+), and 44 (CO_2).

Table 29.3 Common fragments of hexane

Fragment	m/e
CH_3^+	15
C_2H_5^+	29
C_3H_7^+	43
C_4H_9^+	57
$\text{C}_5\text{H}_{11}^+$	71
$\text{C}_6\text{H}_{13}^+$	85

Alkanes

Simple alkanes are fragmented in mass spectroscopy by breaking the C-C bonds. m/e values of some of the common alkane fragments are given in the **Table 29.3**.

The fragmentation of the straight chain hexane: 86, 71, 57, 43, 29 and 15, which is due to the fragment at different location.

- $\text{CH}_3\text{-CH}_2\text{-CH}_2\text{-CH}_2\text{-CH}_2\text{-CH}_3$ (Mass:86)
- $\text{CH}_3\text{-CH}_2\text{-CH}_2\text{-CH}_2^+$ (Mass:57)
- $\text{CH}_3\text{-CH}_2^+$ (Mass:29)
- $\text{CH}_3\text{-CH}_2\text{-CH}_2\text{-CH}_2\text{-CH}_2^+$ (Mass:71)
- $\text{CH}_3\text{-CH}_2\text{-CH}_2^+$ (Mass:43)
- CH_3^+ (Mass:15)

c) The M+1 & M+2 Peaks

i. Determine the Number of Carbon Atoms Using M+1 Peak

The [M+1] peak is caused by the presence of the carbon-13 (^{13}C) isotope in the molecule. Carbon-13 makes up approximately 1.1% of all carbon atoms. Therefore, the [M+1] peak is much smaller than the M peak as the isotope is less common. The ratio of ^{13}C to ^{12}C is approximately 1:99. Thus, the greater the number of carbon atoms present in a molecule the greater the height of the [M+1] peak.

The number of carbon atoms, n, in a compound can be deduced using the [M+1] peak and the following formula:

$$n = \frac{100 \times \text{abundance of [M+1]}}{1.1 \times \text{abundance of M}^+ \text{ ion}}$$

Example 29.5

Determine the number of carbon atoms of compound X with the following mass spectrum:

Answer

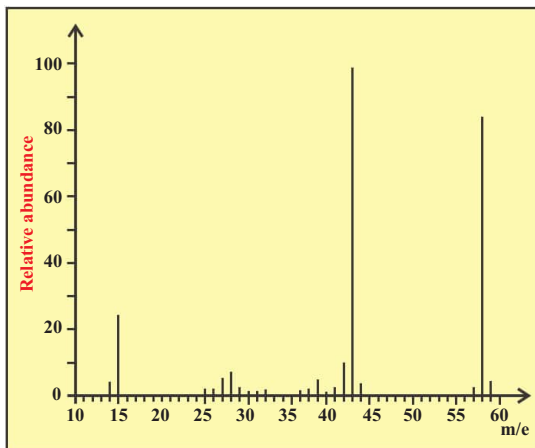
The M ion peak is at m/e 58 with a relative abundance of around 85.

The [M+1] peak is at m/e 59 with a relative abundance of 3.

Therefore, the number of carbon atoms (n) is:

$$n = \frac{100 \times 3}{1.1 \times 85} = 3.21$$

There are, therefore, 3 carbon atoms present in compound X.



ii. Detecting Bromine and Chlorine Atoms Using M+2 Peak

The presence of bromine or chlorine atoms in a compound gives rise to a [M+2] and possibly [M+4] peak

Chlorine

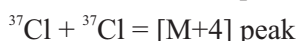
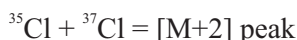
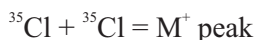
Chlorine exists as two isotopes, ^{35}Cl and ^{37}Cl .

A compound containing one chlorine atom will, therefore, have two molecular ion peaks due to the two different isotopes, it contain,



The ratio of the peak heights is 3:1 (as the relative abundance of ^{35}Cl is 3× greater than that of ^{37}Cl).

A compound containing two chlorine atoms will have three molecular ion peaks due to the different combinations of chlorine isotopes they can contain



The ratio of the peak heights is 9:6:1

Bromine

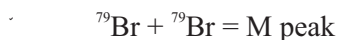
Bromine also exists as two isotopes, ^{79}Br and ^{81}Br .

A compound containing one bromine atom will have two molecular ion peaks

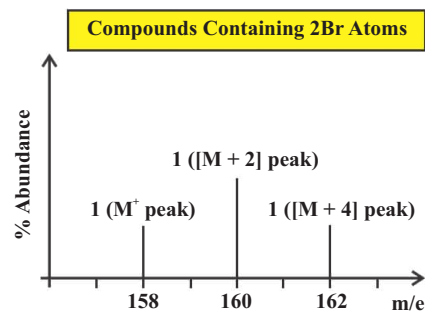
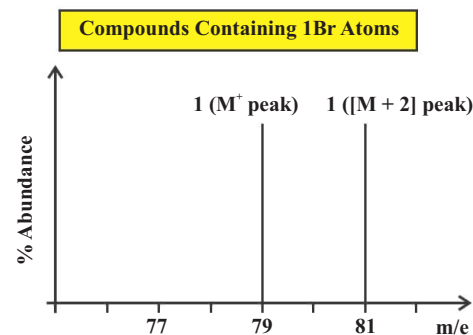
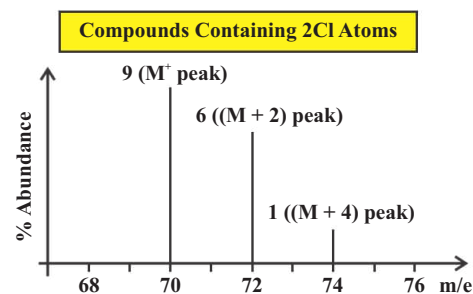
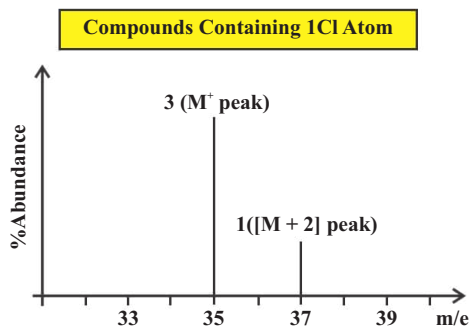


The ratio of the peak heights is 1:1 (they are of similar heights as their relative abundance is the same).

A compound containing two bromine atoms will have three molecular ion peaks.

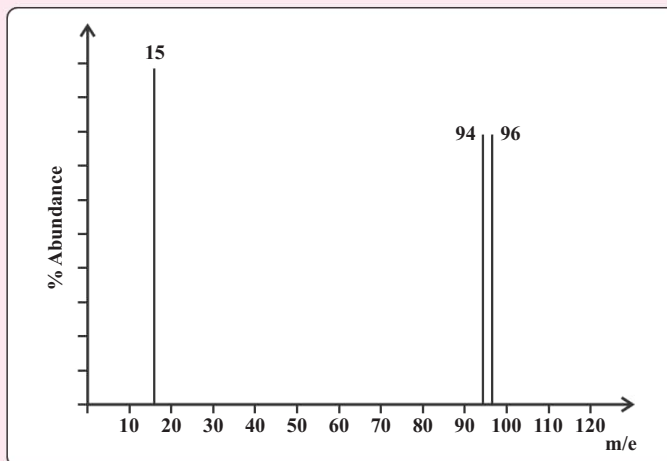


The ratio of the peak heights is 1:2:1




Quick Check 29.3

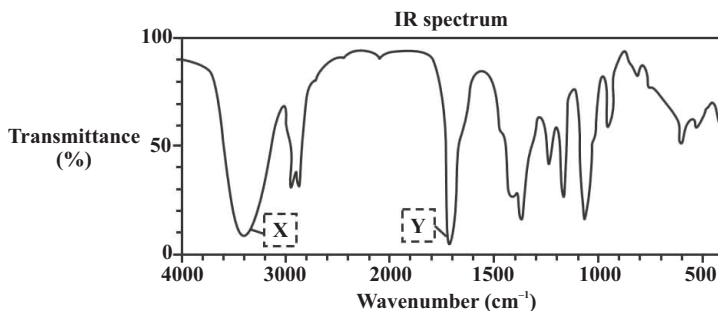

- a) Show all the possible fragments of
- i) C_4H_{10} ii) C_5H_{12} iii) C_7H_{16}
- b) The mass spectrum of CH_3Br is given below.
- i) Identify the fragment against each peak.
- ii) What is the justification of two peaks at 94 and 96?



Exercise

Q1. MULTIPLE CHOICE QUESTIONS:

- I) Which of the following compounds could produce the IR spectrum shown below?



- a) propanoic acid b) 4-hydroxybutanone
- c) pentan-1-ol d) 2-hydroxybut-1-ene
- II. What is the wavelength range of the UV spectrum?
- a) 100 nm to 500 nm b) 200 nm to 800 nm
- c) 300 nm to 1000 nm d) 400 nm to 1600 nm



III. The λ of σ to σ^* transitions lies in the

- a) IR region
b) Visible region
c) UV region
d) None of the above

IV. The types of transitions possible in UV-visible region for a compound with molecular formula C_2H_4 are:

- a) $n \rightarrow \pi^*$
b) $n \rightarrow \sigma^*$
c) $\sigma \rightarrow \sigma^*$
d) $\pi \rightarrow \pi^*$

V. What is index of hydrogen deficiency of C_8H_8 ?

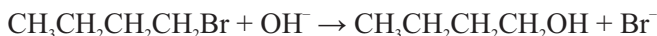
- a) 1
b) 2
c) 3
d) 4

VI. Which of the following statements about the mass spectrum of CH_3Cl is correct?

- a) There is one peak for the molecular ion with an m/e value of 45.
b) There is one peak for the molecular ion with an m/e value of 52.
c) The last two peaks have abundances in the ratio 1:1 and occur at m/e values of 50 and 52.
d) The last two peaks are of equal size and occur at m/e values of 50 and 52.

Q2. SHORT ANSWER QUESTIONS

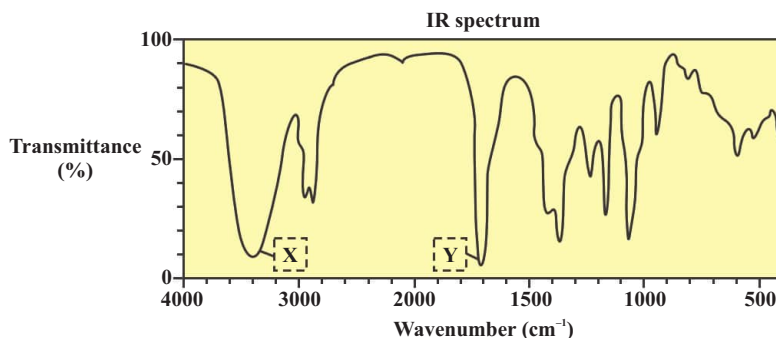
- a) Bromobutane, $CH_3CH_2CH_2CH_2Br$, can be reacted with hot aqueous sodium hydroxide to prepare butan-1-ol.



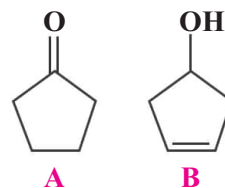
Butan-1-ol produced can be analysed by mass spectrometry.

- i. Predict the formula of fragment ion which is produced to m/e value of 17.
ii. Predict two other fragment ions that you would expect to see in the mass spectrum of butan-1-ol and state the m/e value of each ion.

- b) Identify the functional groups responsible for the peaks labelled X and Y.



- c) Explain how the two isomers shown in the diagram can be distinguished using IR spectroscopy.



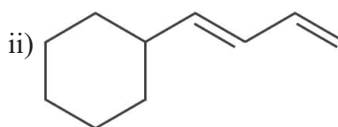
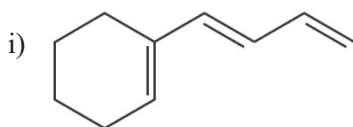
d) The molecular formulas of but-1-ene and but-1,4-diene are given below:

but-1-ene: C_4H_8 but-1,3-diene: C_4H_6

- i. Fine out the IHD for both of these compounds.
- ii. Compare the UV absorption spectrum of but-1-ene to that of but-1,3-diene by stating the difference in their λ_{max} qualitatively.

Q3. CONSTRUCTED RESPONSE QUESTIONS

- a) Compound X is an atmospheric pollutant emitted from fuel combustion of petrol and diesel vehicles. Compound X is a potent human carcinogen. Analysis of compound X showed the following percentage composition by mass: C, 88.89% and H, 11.1%. Mass spectrometry showed a molecular ion peak at $m/e = 54$. Compound X reacts with H_2 in the presence of a nickel catalyst in a 1 : 2 molar ratio. Analyse and interpret this information to determine a possible structure for compound X. Show all your working.
- b) How will you differentiate between the following using the UV visible spectroscopy.



DESCRIPTIVE QUESTIONS

- Q4. Describe various possible electronic transitions in a compound having sigma, pi bonds, and non-bonding electrons.
- Q5. Explain two types of atomic spectrum.
- Q6. How mass spectrometry is used to determine the isotopic mass and average atomic masses of elements? Explain giving an example.



30

SPECTROSCOPY-2
NMR

Student Learning Outcomes

[C-12-E-19 to C-12-E-28]

- Explain the use of tetramethylsilane, TMS, as the standard for chemical shift measurement.
- Recognize the need for deuterated solvents, e.g., CDCl_3 , when obtaining a proton NMR spectrum.
- Analyze the different environments of protons present in a simple molecule using a ^1H (proton) NMR spectrum.
- Predict the chemical shifts and splitting patterns of the protons in a given molecule.
- Use a ^1H (proton) NMR spectrum to deduce relative numbers of each type of proton present, the number of equivalent protons on the carbon atom adjacent to the one to which the given proton is attached.
- Describe the identification of O-H and N-H protons by proton exchange using D_2O .
- Deduce possible structures for the molecule.
- Predict the number of peaks in a ^{13}C NMR spectrum for a given molecule.
- Analyze the different environments of carbon atoms present in a simple molecule using a ^{13}C NMR spectrum.
- Use a ^{13}C NMR spectrum to deduce possible structures of a simple molecule.

Nuclear Magnetic Resonance (NMR) spectroscopy is a powerful technique which is extensively used in chemistry, polymer industry, study of proteins and natural products, environment monitoring, and medical field. In chemistry, this technique is particularly used for the identification of organic compounds and determination of their structures. Proton (^1H) NMR and carbon-13 (^{13}C) NMR are two most commonly used methods in this regard.

30.1 PRINCIPLE OF PROTON (^1H) NMR

NMR spectroscopy is based on the magnetic properties (nuclear spin) of nuclei. Atoms with odd mass numbers usually show signals on NMR. The atomic nuclei of these atoms, such as hydrogen (^1H) and carbon-13 (^{13}C) behave like a tiny magnet. In the absence of a magnetic field, all the nuclei have random orientation and have the same energy. When placed in a strong magnetic field, these nuclei align themselves either with or against the field and give rise to two spin states i.e., low energy state and high energy state (Figure 30.1).

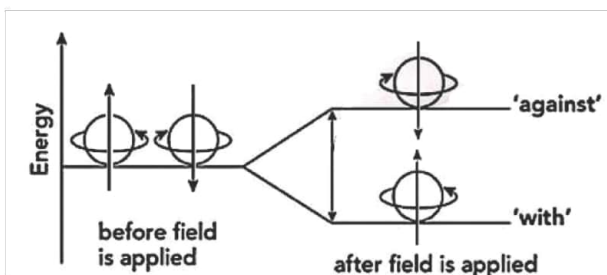


Figure 30.1 Alignment of nuclei in a magnetic field and spin flipping





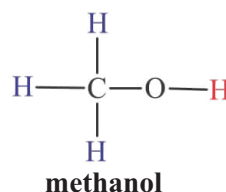
Did You Know?

The atoms with even atomic and mass numbers have equal number of protons and neutrons in their nuclei. As their magnetic fields cancel out each other, there is no net magnetic field of such nuclei e.g., ^{12}C .



By irradiating with radio waves, the nuclei at low energy state can absorb energy and move to higher energy state (spin flipping). When they return to their original states, they emit energy which is detected and converted into an NMR spectrum (plural spectra). The exact energy required to flip a nucleus depends upon its position in a compound and the surrounding atoms, collectively known as the molecular environment. Thus, NMR can be used to identify different hydrogen atoms lying in different environments within one molecule. For example, in the methanol (CH_3OH) molecule, three hydrogen atoms are attached to a carbon atom and one hydrogen atom is bonded to an oxygen atom. The methyl ($-\text{CH}_3$) hydrogens and hydroxyl ($\text{O}-\text{H}$) hydrogen lie in different environment, so they absorb different amount of energy (different frequency of radio waves) for flipping.

Nuclei lying in different environments can be flipped by using the radio waves of same frequency, if the strength of magnetic field is varied.



30.2 SOLVENTS FOR NMR SPECTROSCOPY

In the ^1H NMR analysis the sample to be analyzed is dissolved in excess solvent to prepare a solution. Ordinary solvents contain hydrogen atoms which produce strong signals and cause interference in the spectrum of the sample. To avoid this problem, deuterated solvents such as CDCl_3 (deuterated chloroform) or CD_3OD (deuterated methanol), are used. If regular CHCl_3 is used as a solvent, the signal from its single proton (^1H) would be intense enough to completely overlap and mask the weaker signals arising from the protons in the actual sample. In CDCl_3 , hydrogen (H) is replaced with its isotope Deuterium (D). Deuterium requires a different frequency of radio waves for flipping, hence it neither absorbs radio frequency provided to the sample solution nor its peak appears in the ^1H NMR spectrum. This makes the solvent "silent", and only the signals of the sample are observed in the spectrum.

30.3 CHEMICAL ENVIRONMENT AND CHEMICAL SHIFT (δ)

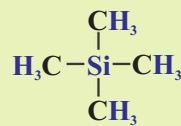
Chemical shift is an important parameter in NMR spectroscopy and represents the position of a signal relative to a reference compound. Tetramethylsilane, $\text{Si}(\text{CH}_3)_4$ (commonly known as TMS) is used as the standard reference and its signal is assigned a value of 0.0 ppm. All other signals due to the hydrogen nuclei (protons) in the sample compounds are measured relative to this TMS zero point. **The position of a peak in a ^1H NMR spectrum relative to TMS peak is called the chemical shift (δ) which is measured in parts per million (ppm) unit.** Chemical shift indicates the electronic environment of a proton. Protons in different environments have different δ values, while those lying in same environment have same δ value.





Did You Know?

TMS is particularly suitable as a standard compound for NMR because all 12 of its protons have the same chemical environment and produce a single sharp peak. Moreover, the protons on TMS appear at the extreme right region of the spectrum (due to the low electronegativity of silicon) and do not overlap with most organic proton signals. TMS is chemically inert and volatile, which makes it easy to remove after use.



Tetramethylsilane (TMS)

For example, in the ^1H NMR spectrum of methanol (**Figure 30.2**), the relative position of peak for methyl ($-\text{CH}_3$) hydrogens at 3.35 ppm compared to 0.0 ppm of TMS is the chemical shift of these protons. Similarly, O-H hydrogen of methanol has a chemical shift of 4.80 ppm.

Protons (^1H) in a molecule are surrounded by electrons and this electron density affects the appearance of an NMR spectrum. Protons in different parts of a molecule are in different "environments" because of the atoms and bonds near them.

All the protons (^1H) found in chemically identical environments within a molecule are chemically equivalent, and they exhibit the same chemical shift in the ^1H NMR spectra of that molecule. All the protons in TMS, methane, ethane, benzene and propanone (acetone) are chemically equivalent. Each of these compounds gives rise to a single absorption peak in its ^1H NMR spectrum (**Figure 30.3**).

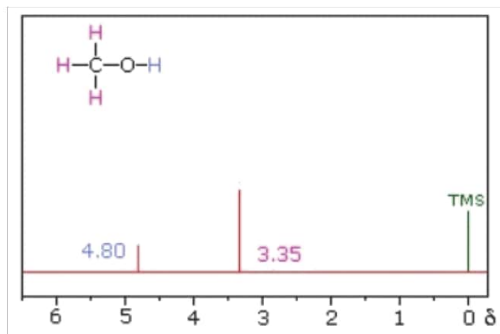
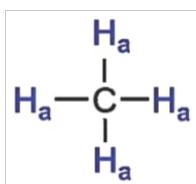
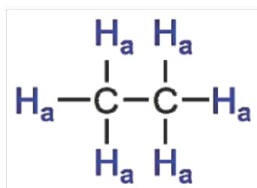


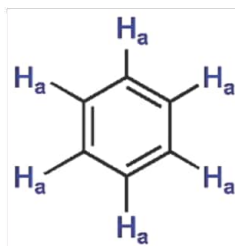
Figure 30.2 ^1H NMR Spectrum of Methanol



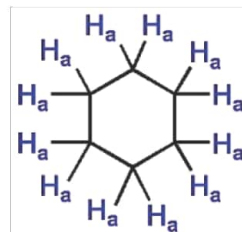
methane



ethane



benzene



cyclohexane

All the hydrogen atoms in these molecules have same chemical environment

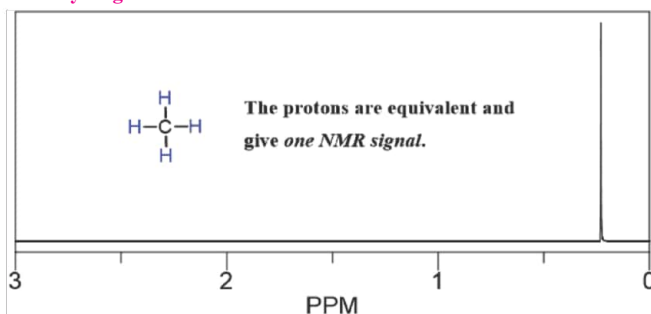
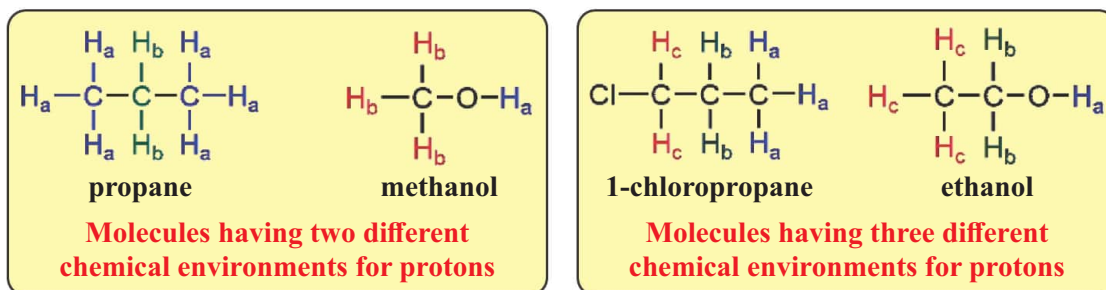


Figure 30.3 ^1H NMR spectrum of methane



On the other hand, a molecule which has sets of protons that are chemically different from one another, have different chemical shift and give rise to more than one peaks.



For example, a proton on a $-\text{CH}_3$ group is different from the one on $-\text{CH}_2-$ and $\text{O}-\text{H}$ in ethanol ($\text{C}_2\text{H}_5\text{OH}$) molecule. Similarly, all the three protons of $-\text{CH}_3$ have same environment, while the two protons of $-\text{CH}_2-$ have same environment. The chemical shift of a proton (^1H) is affected by the electron density of its surrounding chemical environment. Protons surrounded by high electron density (alkyl groups) have lower chemical shift values, whereas protons surrounded by a low electron density (near electronegative atoms like F, O, N, Cl etc.) appear at high chemical shift values. For example, methyl ($-\text{CH}_3$) protons in the ^1H NMR spectrum of methanol appear at 3.35 ppm due to a higher electron density around them as compared to $\text{O}-\text{H}$ proton, which appears at 4.80 ppm due to the presence of electronegative oxygen next to it (**Figure: 30.2**).

A ^1H NMR spectrum has a chemical shift (δ) range of 0 – 12 ppm. The chemical shifts for different environments of protons have been given in **Table 30.1**. This data table is helpful in identifying and predicting the environment of protons in ^1H NMR spectrum of an unknown compound.

Table 30.1 Chemical shifts of some common types of protons

Environment of Proton	Examples	Chemical Shift Range δ (ppm)
Alkyl (alkanes)	$-\text{CH}_3$, $-\text{CH}_2-$, $>\text{CH}-$	0.5 – 1.5
Alkyl next to $\text{C}=\text{O}$ (ketone/ester)	$\text{CH}_3-\text{C}=\text{O}$, $-\text{CH}_2-\text{C}=\text{O}$, $>\text{CH}-\text{C}=\text{O}$	2.0 – 2.6
Alkyl next to aromatic ring	CH_3-Ar , $-\text{CH}_2-\text{Ar}$, $>\text{CH}-\text{Ar}$	2.3 – 3.0
Alkyl next to electronegative atom (halogenoalkanes, alcohols)	CH_3-O , $-\text{CH}_2-\text{O}$, CH_3-Cl , $-\text{CH}_2-\text{Cl}$	3.0 – 4.5
Vinylic (alkenes)	$>\text{C}=\text{CHR}$	4.5 – 6.0



Aromatic (attached to aromatic ring)	Ar-H	6.5 – 9.0
Aldehyde	RCHO	9.0 – 10.0
Alcohol	ROH	0.5 – 6.0
Phenol	Ar-OH	4.5 – 7.0
Carboxylic acid	RCOOH	9.0 – 13.0
Alkyl amine	R-NH-	1.0 – 5.0
Aryl amine	Ar-NH ₂	3.0 – 6.0
Amide	RCONHR	5.0 – 12.0



Quick Check 30.1



- Explain why the 12 protons in TMS produce only a single peak.
- Identify how many chemical environments are there for protons in the following molecules. Also predict the expected chemical shift of the protons in each environment.
 - 1,1,2,2-dichloroethane
 - propane
 - propan-2-ol
 - butan-2-one
- What proton environment does a signal at δ 7.5 ppm likely represent?

30.4 INTERPRETATION OF ¹H NMR SPECTRA

30.4.1 Low-Resolution ¹H NMR Spectra

A low-resolution ¹H NMR spectrum provides three main pieces of information about the structure of a compound; the number of different proton environments in the molecule, types of these environments, and the relative number of protons in each environment. While interpreting a ¹H NMR spectrum, three parameters are carefully analysed; total number of peaks in the spectrum, position of each peak (chemical shift δ), and the area under each peak. **The number of peaks in a ¹H NMR spectrum corresponds to the number of different chemical environments for protons present in the molecule.** Each peak in the spectrum stands for a different chemical environment.

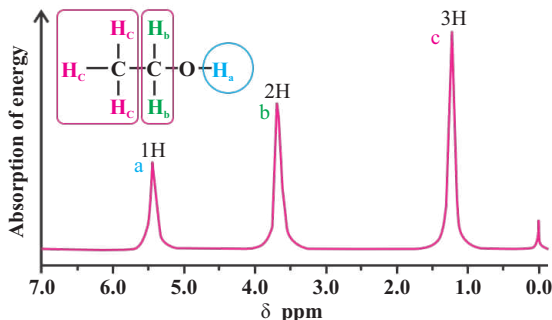


Figure 30.4 Low-resolution ¹H NMR spectrum of ethanol



Low-resolution ^1H NMR spectrum of ethanol ($\text{CH}_3\text{CH}_2\text{OH}$) has been illustrated in **Figure 30.4**. The spectrum has three peaks which shows that there are three different proton environments in ethanol molecule *i.e.*, the CH_3 protons, the CH_2 protons, and the OH proton.

Chemical shift of each peak corresponds to the type of chemical environment of protons giving rise to that peak. The type of proton environment can be identified by comparing the chemical shifts to standard values (**Table 30.1**). In the spectrum of ethanol (**Figure 30.4**), the peak at 5.4 ppm represents the presence of electrons in less electron density environment (OH). The peak having chemical shift 3.7 ppm can be identified as $-\text{CH}_2-$ next to oxygen while the signal at 1.2 ppm can be identified as methyl group ($-\text{CH}_3$ protons).

The **area under each peak** is proportional to the **number of protons** giving rise to that peak.

In the ^1H NMR spectrum of ethanol (**Figure 30.4**), peaks are labeled 1H, 2H and 3H to show relative peak areas in 1:2:3 ratio. This ratio matches with the number of protons in each environment ($-\text{OH}$ has 1, $-\text{CH}_2$ has 2 and $-\text{CH}_3$ has 3 protons). Analysis of the above spectrum shows that there are three kinds of chemical environments for protons, so three signals are observed. The intensity ratio shows that they are present in the ratio of 1:2:3. **The sum of number of each type of protons gives the total number of protons present in the molecule.** Hence, there are total 6 hydrogen (1+2+3) atoms in an ethanol molecule.



Quick Check 30.2



- What does the **number of signals** in a ^1H NMR spectrum represent?
- Predict the number of peaks that will appear in the ^1H NMR spectra of the following molecules?
(i) 1,1,2,2-dichloroethane (ii) butane (iii) propan-2-ol (iv) pentan-3-one (v) benzene
- Predict the number of peaks and their chemical shifts in the ^1H NMR spectrum of bromoethane ($\text{CH}_3-\text{CH}_2-\text{Br}$).
- How many signals will be observed in the ^1H NMR spectrum of 2-chlorobutane. Draw its structure and identify the hydrogen atoms which will show the highest value of chemical shift.
- What does the peak area in ^1H NMR represent?

30.4.2 High-Resolution ^1H NMR and Splitting of Peaks

The NMR signals of protons are not only affected by the nearby electrons, but also by protons on the adjacent atoms. This effect can be observed by a high-resolution NMR. When a high-resolution ^1H NMR spectrum of a molecule is studied, it reveals that each peak is often made up of a cluster of sub-peaks. This is due to the splitting of each signal due to the presence of protons (^1H) on adjacent carbon atoms. **The splitting of signals into multiple peaks (e.g., doublets, triplets, quartets) indicates the number of protons (^1H) on the adjacent (neighbouring) carbon atom.** Number of sub-peaks can be calculated by using '**n+1**' rule. A signal usually splits into n+1 sub-peaks, where n is the number of protons on adjacent carbon atoms.

$$\text{Number of sub-peaks} = n + 1$$

(Where n = the number of protons on the adjacent carbon atom).



In the high-resolution ^1H NMR spectrum of ethanol, the $-\text{CH}_3$ peak is split into three sub-peaks (known as **triplet**) because the number of protons on adjacent carbon is 2 ($2+1=3$). Similarly, $-\text{CH}_2-$ peak is split into four sub-peaks (known as a **quartet**) because there are 3 protons on its adjacent carbon ($3+1=4$). The $-\text{OH}$ signal is not split because hydrogen is bonded to an oxygen atom instead of carbon atom (**Figure 30.5**).

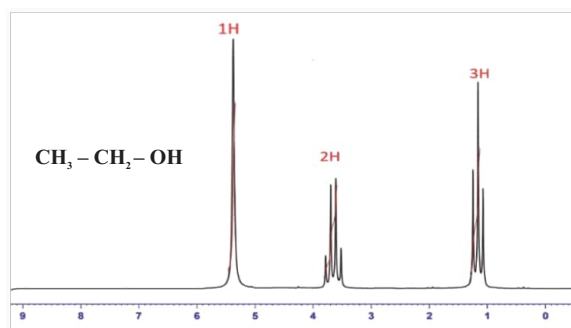


Figure 30.5 High-resolution ^1H NMR spectrum of ethanol

This is important to note that $-\text{OH}$ and $-\text{NH}$ protons usually do not show splitting, so these appear as **singlet** peak. Similarly, chemically equivalent protons do not cause splitting of their neighbouring protons. For example, the ethane (CH_3-CH_3) molecule has two methyl groups attached to each other. If one methyl group is considered, its adjacent carbon has 3 protons attached to it. However, the peak does not show splitting because all the hydrogen atoms in ethane are chemically equivalent (**Figure 30.6**).

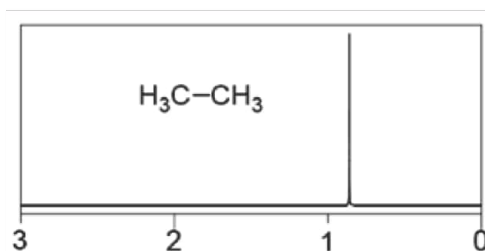


Figure 30.6 High-resolution ^1H NMR spectrum of ethane

The number of sub-peaks for different number of neighbouring protons and their appearance given in **Table 30.2** is useful to recognise splitting patterns in high-resolution ^1H NMR spectra.

Table 30.2 Common splitting patterns in high-resolution ^1H NMR spectra

No. of Protons on Adjacent Carbon Atom (n)	Number of Sub-Peaks (n+1)	Splitting Pattern	Abbreviation	Appearance of Split Peak
0	1	Singlet	s	
1	2	Doublet	d	



2	3	Triplet	t	
3	4	Quartet	q	


Quick Check 30.3


- a) A signal in the ^1H NMR spectrum is a **quartet**. How many adjacent, equivalent protons ('n') are there?
- b) Calculate the number of sub-peaks for each signal in the high-resolution spectra of the following compounds?
- butan-2-ol
 - 1-chloropropane
 - propanone
 - 2,2-dimethylpropane
 - methanol

30.4.3 Identification of O-H and N-H Proton in ^1H NMR Spectrum

The hydrogen atoms in O-H (alcohols or carboxylic acids) and N-H (amines or amides) are easily exchangeable, due to which they show a wide range of chemical shift value for their singlet peak.



Sometimes, it becomes very difficult to identify these peaks in spectra. A technique known as 'deuterium exchange' or 'D₂O shake' is used to detect whether the singlet in a ^1H NMR spectrum is actually due to the presence of an O-H or N-H hydrogen. In this method, the ^1H NMR spectrum of the compound is recorded which shows all the H atoms in the molecule including the O-H or N-H proton(s). A few drops of D₂O are then added to the NMR sample tube, the solution is shaken well and its spectrum is recorded again. The peak belonging to O-H or N-H proton disappears in the second spectrum. Comparing both spectra confirms the identity of the peak arising due to N-H or O-H.

The reason for this observation is that protons (^1H) attached to highly electronegative atoms like O or N are easily exchanged. When D₂O is added to the sample solution, these hydrogens are quickly exchanged with the deuterium (D) atoms.



As deuterium atom requires different energy for spin flipping as compared to ^1H , it does not show a peak in the ^1H NMR spectrum making it '*invisible*'.


Quick Check 30.4


- a) Why do **O-H** or **N-H** peaks disappear after a D₂O shake?
- b) State the expected **peak area** and **splitting patterns** for (-CH₂CH₂NH₂).



30.5 PREDICTION OF ^1H NMR SPECTRUM FOR A GIVEN MOLECULE

After understanding the concepts of chemical environment, chemical shift and splitting of peaks, one can predict the ^1H NMR spectrum of a given molecule by analyzing its structure. This can be done in the following steps:

Step I: Identify different proton environments in the molecule.

Number of different environments = Number of peaks expected in spectrum

Step II: Estimate the chemical shift (δ) for each set of protons having same chemical environment by using known ranges from the data table (**Table 30.1**). If the data table is not available, check the nearest bonds and atoms. The protons near electronegative elements have higher chemical shift (δ), while those with alkyl groups generally have lower chemical shift.

Step III: Predict the splitting pattern of each peak by applying the 'n+1' rule.

Step IV: Assign integration ratios according to the number of hydrogen atoms in each environment.

Example 30.1:

Predict the ^1H NMR spectrum of chloroethane ($\text{CH}_3\text{-CH}_2\text{-Cl}$).

Solution:

No. of peaks

Two different chemical environments are present in the molecule.

No. of peaks in the ^1H NMR spectrum of chloroethane = 2

Chemical shift

The $-\text{CH}_2-$ is attached to an electronegative element, it will show a higher value of chemical shift (3.0 – 4.5 ppm). The methyl protons will show lower value of chemical shift (0.5 – 1.5 ppm).

Splitting of Peaks

No. of sub-peaks for $-\text{CH}_3 = 2 + 1 = 3$ (The carbon adjacent to $-\text{CH}_3$ has 2 protons)

$-\text{CH}_3$ signal will split into a **triplet**.

No. of sub-peaks for $-\text{CH}_2- = 3 + 1 = 4$ (The carbon adjacent to $-\text{CH}_2-$ has 3 protons)

$-\text{CH}_2-$ signal will split into a **quartet**.

Relative peak area

The ratio of peak area for $-\text{CH}_3$ and $-\text{CH}_2-$ will be 3:2.



Quick Check 30.5



For the compound $(\text{CH}_3)_2\text{CHOH}$, predict the following:

- | | |
|----------------------------|--|
| a) The number of peaks | b) The type of proton and chemical shift |
| c) The relative peak areas | d) The splitting pattern |



30.6 DETERMINATION OF THE POSSIBLE STRUCTURE OF A MOLECULE FROM ^1H NMR

The structure of an unknown compound can also be deduced by analyzing its ^1H NMR spectrum. It can be done by putting together the following key pieces of information like a puzzle. To determine the structure:

- Count the number of peaks in the spectrum.

$$\text{No. of peaks} = \text{No of protons}$$

- Use the chemical shift of each peak to identify functional groups (use data table).
- Use peak area to find the actual number of hydrogen atoms for each peak (this gives the no. of hydrogen atoms present in each environment)
- Analyze the splitting pattern and calculate the number of adjacent protons

$$\text{No. of sub-peaks} = n + 1$$

$$n = \text{No. of sub-peaks} - 1$$

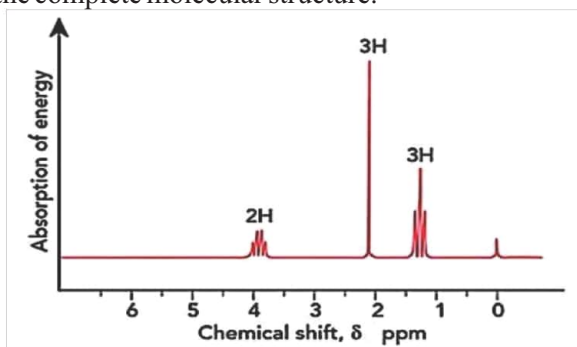
- Combine this information to assemble the complete molecular structure.

Example 30.2

The ^1H NMR spectrum of an ester is given below. Deduce the structure of the ester.

Solution:

The solution is given in the table below.



No.	Peak Chemical Shift (ppm)	No. of Equivalent protons	Responsible Group	Splitting	No. of Neighbouring Protons
1	1.3	3H	$-\text{CH}_3$ next to $-\text{CH}_2$	Triplet	$3-1 = 2\text{H}$ (CH_3-CH_2-)
2	2.2	3H	$-\text{CH}_3$ next to $\text{C}=\text{O}$	Singlet	$1-1 = 0$ ($\text{CH}_3-\text{C}=\text{O}$)
3	3.9	2H	CH_2- next to an electronegative O atom	doublet	$2-1 = 1$ ($\text{CH}_3-\text{CH}_2-\text{O}$) Combining information from 1 and 3
Overall Structure		$\begin{array}{c} \text{O} \\ \parallel \\ \text{H}_3\text{C}-\text{C}-\text{O}-\text{CH}_2-\text{CH}_3 \end{array}$			



30.7 ^{13}C NMR SPECTROSCOPY

The nucleus of ^{12}C does not have magnetic properties because of even number of protons and neutrons (even mass number), and is, therefore, NMR inactive. However, the ^{13}C nucleus possesses magnetic spin due to its odd number of neutrons. On the basis of the magnetic properties of carbon-13 isotope, ^{13}C NMR spectra can be recorded for carbon compounds. Like ^1H NMR, chemical shift (δ in ppm) in ^{13}C NMR is compared to the reference molecule TMS ($\delta = 0.0$ ppm). However, the ^{13}C NMR has a range of chemical shift from 0 – 220 ppm. The deuterated chloroform (CDCl_3) is usually used as a solvent which produces a small signal near 80 ppm.

30.7.1 Chemical Environment of Carbon

A carbon atom's environment is determined by the types of atoms directly attached to it. Carbon atoms that are in the same environment are chemically equivalent, and show the same chemical shift. For example, both carbon atoms in ethane have the same environment. Carbon atoms in different environments are chemically non-equivalent and they will appear at different positions (chemical shifts) in ^{13}C NMR spectra. For example, all three methyl carbon atoms in 2-methylpropane have the same environment, while the tertiary carbon has different environment than these three carbon atoms.

The type of environment can be predicted by looking at atoms or bonds around carbon atoms. The chemical shifts of different carbon environments are given in **Table 30.3**.

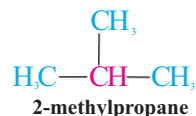



Table 30.3 Chemical shifts of different carbon environments

Hybridization of carbon atom	Environment of carbon atom	Examples	Chemical Shift Range δ (ppm)
sp^3	Alkyl	CH_3 , $-\text{CH}_2-$, $>\text{CH}-$, $>\text{C}<$	0 – 50
sp^3	Carbon atom next to alkene or aryl ring	$-\text{C}-\text{C}=\text{C}$, $-\text{C}-$	25 – 50
sp^3	Carbon atom next to carbonyl or carboxyl	$-\text{C}-\text{COR}$, $-\text{C}-\text{COOR}$	30 – 65
sp^3	Carbon atom next to halogen	$\text{C}-\text{X}$	30 – 60
sp^3	Carbon atom next to oxygen	$\text{C}-\text{O}$	50 – 70



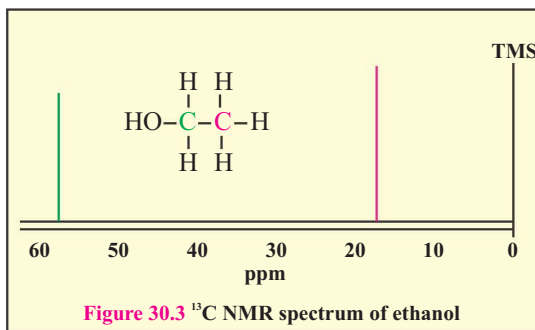
sp^2	Alkene or aryl carbon	$>C=C<$, 	110 – 160
sp^2	Carboxyl carbon	R-COOH, -COOR	160 – 185
sp^2	Carbonyl carbon	R-CHO, R-CO-R	190 – 220
sp	Nitrile	R-C≡N	100 – 125

30.7.2 Predicting ^{13}C NMR Spectra

The ^{13}C NMR spectrum is simpler than ^1H NMR in which each peak (or signal) corresponds to a single, different environment or type of carbon atom. Chemical shift of each peak tells about its environment.

The number of peaks = The number of different carbon environments

^{13}C NMR spectrum of ethane shows only one peak as both the carbon atoms have the same environment. In propane $\text{CH}_3-\text{CH}_2-\text{CH}_3$, there are two types of carbon environments, the two terminal $-\text{CH}_3$ carbons have the same environment while the middle $-\text{CH}_2-$ carbon has a different environment. The ^{13}C NMR spectrum of propane shows two peaks, one for the methyl carbon atoms while the other for $-\text{CH}_2-$ carbon atom. Similarly, two peaks are observed in the ^{13}C spectrum of ethanol ($\text{CH}_3-\text{CH}_2-\text{OH}$), due to the presence of two types of environments in this molecule (**Figure 30.7**).



Analyzing the ^{13}C NMR spectrum of ethanol by using the data given in **Table 30.3**, it is evident that the peak at 18 ppm is for $-\text{CH}_3$ carbon, while the peak near 57 ppm is due to $-\text{CH}_2-$ carbon atom.

There are two key differences between ^1H NMR and ^{13}C NMR spectra. The relative peak area in ^{13}C NMR is usually not proportional to the number of carbon atoms unlike ^1H NMR in which peak area shows the number of protons. Secondly, the peaks do not show splitting, hence these appear as vertical lines. Due to this, ^{13}C NMR technique is less sensitive than ^1H NMR.



Quick Check 30.6



- How many signals do you expect to observe in the ^{13}C NMR spectrum of **butane**? Justify your answer.
- Predict the ^{13}C NMR spectrum of butan-2-ol.
- Predict the chemical shift of carbon atoms in propanoic acid.

30.7.3 Determination of Structure of a Molecule

The ^{13}C NMR spectrum can be used to figure out a molecule's structure. The steps during the analysis of a spectrum are:



1. Count the Peaks

The number of peaks in the spectrum tells the number of different types (environments) of carbon atoms in the molecule. If a molecule has 5 carbon atoms but only 3 peaks, it means there are 2 pairs of carbons, which are identical (chemically equivalent).

2. Look at the Position of Peak (Chemical Shift δ)

The position (ppm value) of each peak tells whether the carbon atom is present in an alkane, alkene, alkyne, aromatic or carbonyl compound. The assignment of the chemical shift value can be made according to the data provided in **Table 30.3**.

3. Work out the spectrum for possible structures

Use the information from the peak count and positions to draw possible structures that fit the molecular formula of the compound.

If the formula of a compound is $C_4H_{10}O$ and its ^{13}C NMR spectrum shows 3 peaks (**Figure 30.8**). It means that 3 different carbon environments are present in the molecule. The three possible molecules for this formula are butan-1-ol, butan-2-ol and 2-methoxypropane. The structure of the unknown compound cannot be butan-1-ol or butan-2-ol (which are expected to show 4 peaks). It must be a structure with 3 chemical environments; 2-methoxypropane which has 3 peaks.

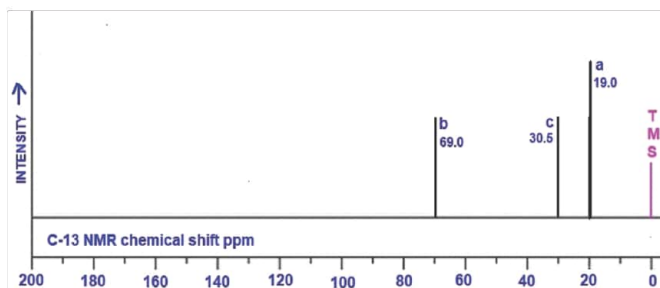


Figure 30.8 ^{13}C NMR spectrum of an unknown molecule



Quick Check 30.7



Draw the structures of butan-1-ol and butan-2-ol.

- Using the spectrum given in **Figure 30.8**, explain why this spectrum does not match with the structures of these two molecules.
- Which peaks (mention chemical shift) would you expect in the spectra of butan-1-ol and butan-2-ol?

Exercise

Q1. MULTIPLE CHOICE QUESTIONS

I. NMR relies on the magnetic properties of nuclei known as:

- | | |
|-------------------|---------------------|
| a) Chemical shift | b) Nuclear density |
| c) Nuclear spin | d) Signal intensity |

II. Chemical shift (δ) in the 1H NMR spectroscopy is measured relative to TMS and is expressed in:

- | | |
|----------------------------|------------------------------------|
| a) Tesla (T) | b) Hertz (Hz) |
| c) Parts per million (ppm) | d) Degrees Celsius ($^{\circ}C$) |



III. Deuterated solvents (CDCl_3) are used in ^1H NMR to:

- a) Increase magnet strength
- b) Split the signals
- c) Provide a reference signal
- d) Avoid solvent signal interference

IV. The primary purpose of measuring the peak area in ^1H NMR is to find the:

- a) Chemical shift
- b) Number of neighboring protons
- c) Total carbon atoms
- d) Relative number of protons

V. Splitting is typically not observed for O-H or N-H protons because of:

- a) NMR-inactivity
- b) Longer bond
- c) Deuterated solvent
- d) Rapid chemical exchange

VI. In the n+1 splitting rule, 'n' represents the number of protons on:

- a) the entire molecule
- b) the carbon being analyzed
- c) adjacent carbon atoms
- d) the signal's total area

VII. The chemical shift (δ) of a ^{13}C peak identifies the:

- a) Number of adjacent carbons
- b) Functional group environment ($\text{C}=\text{C}$, $\text{C}=\text{O}$, etc.)
- c) Molecule's symmetry
- d) Number of protons

VIII. The number of peaks in a ^{13}C NMR spectrum equals the number of:

- a) Total carbon atoms
- b) Chemically non-equivalent carbons
- c) Adjacent hydrogen atoms
- d) ^{12}C atoms

IX. How many ^{13}C peaks does propane ($\text{CH}_3\text{CH}_2\text{CH}_3$) show?

- a) 1
- b) 2
- c) 3
- d) 4

X. What is the splitting pattern for a proton with 2 neighbouring protons ($n=2$)?

- a) Singlet
- b) Doublet
- c) Triplet
- d) Quartet

Q2. SHORT-ANSWER QUESTIONS

- a) State two reasons why TMS is a standard for ^1H NMR.
- b) Why does deuterium (D) not appear in a ^1H NMR spectrum?
- c) A compound ($\text{C}_4\text{H}_{10}\text{O}$) has a ^1H NMR peak area ratio of 1:3:6. How many protons does each signal represent?
- d) What is the purpose of the D_2O shake test in ^1H NMR?
- e) List the key features used to interpret a ^1H NMR spectrum.



f) What does the number of peaks in a ^{13}C NMR spectrum represent?

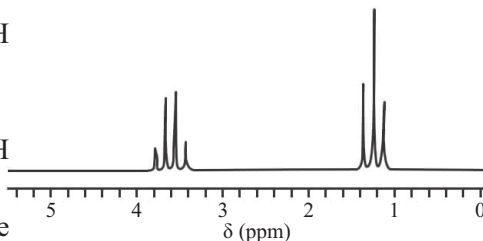
Q3. CONSTRUCTED RESPONSE QUESTIONS

- a) A $-\text{CH}_2-$ group is lying between a $-\text{CH}_3$ and a $-\text{CH}<$ group. What is the splitting pattern for the $-\text{CH}_2-$ signal? Show your calculation.
- b) Predict the ^1H NMR spectrum of 1-butanoic acid.
- c) An organic compound has a molecular formula $\text{C}_2\text{H}_5\text{Cl}$. The ^1H NMR of the compound is given below. Deduce the structure of the compound by using its spectrum. Explain your working in detail.
- d) An organic compound has a formula $\text{C}_4\text{H}_8\text{O}$. In laboratory, the compound gives 2,4-DNPH and iodoform tests positive but Fehling's test shows a negative result. The ^1H NMR of the compound is shown below. Deduce the structure of the compound and justify your answer.

DESCRIPTIVE QUESTIONS

Q4. A chemist suspects a sample contains an O-H group.

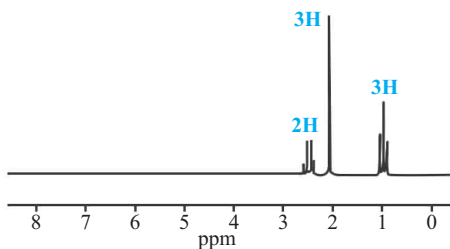
- a) Describe the " D_2O shake" procedure.
- b) What is the expected observation in the ^1H spectrum after the shake?
- c) Write the equilibrium equation for the exchange and explain why it causes this observation.



Q.5 Predict the number of ^{13}C NMR peaks for the following two isomers:

- a) Pentane
- b) 2,2-dimethylpropane

Justify each answer by identifying the sets of equivalent carbons.



31

MATERIALS AND ENERGY

Student Learning Outcomes

[C-12-E-34 to C-12-E-49]

- ⊙ Explain the properties of different materials and how they can be applied to desired structures.
- ⊙ Explain the process of extracting metals from ores and alloying them to achieve desired characteristics.
- ⊙ Explain the mechanism of catalysts and how they increase the rate of reaction while remaining unchanged at the end.
- ⊙ Explain the challenges associated with recycling and toxicity of some materials produced through materials science.
- ⊙ Explain the use of X-ray crystallography in analyzing structures.
- ⊙ Differentiate between petrochemicals and chemicals derived from them.
- ⊙ Identify the various raw materials for the petrochemical industry.
- ⊙ Explain the process of fractional distillation and refining of petroleum.
- ⊙ Describe the major chemical processes involved in the petrochemical industry.
- ⊙ Identify major petrochemicals and their applications.
- ⊙ Differentiate between energy density and specific energy.
- ⊙ Describe the nature, uses, and impact of fossil fuels.
- ⊙ Describe the processes of nuclear fission and fusion and their energy significance.
- ⊙ Explain the working and significance of solar panels as a source of energy.
- ⊙ Explain the environmental impact of energy consumption, particularly in relation to global warming and its relation to the importance of reducing carbon footprint and moving towards sustainable energy sources.
- ⊙ Evaluate different energy sources based on cost, efficiency, impact, and sustainability.

Humans have long benefited from natural resources for their daily needs. The most ancient materials are wood, metals, and those obtained from animals, such as clothes. With an enormous increase in the human population and limited natural resources, new materials and machines were needed to fulfill the human needs. It resulted in the invention of a large number of materials from metal alloys to nanomaterial, from large electric cells to very efficient miniature batteries, etc. The presently used machines such as computers, mobiles, construction machinery, aircrafts, etc., all involve a combination of modern materials and energy devices.

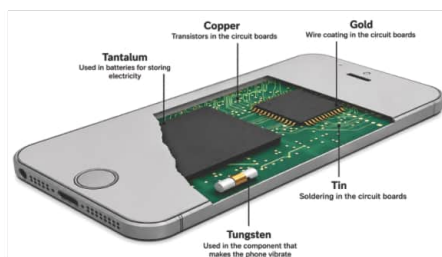


Figure 31.1 This mobile contains a variety of metals, plastic, their composites, and a small but efficient energy device, i.e., Li-ion battery



This chapter gives an introduction to the role of chemistry in modern materials and energy sources.

It discusses the preparation, properties, and uses of a variety of materials, such as metals, alloys, polymers and ceramics, as well as the analytical techniques used for their analysis, such as X-ray crystallography. The chapter also looks at the important definitions including energy density, specific energy, and efficiency of the source, e.g., fossil fuel, nuclear and solar energy. It also highlights the environmental effects of the energy consumption. Finally, a discussion on the sustainable energy sources, such as photochemical energy devices, is given.

31.1 MATERIALS

A material is any substance or mixture of substances that makes up a physical object of daily-life or industrial importance, for example, plastics, metals, ceramics, building material, etc. Materials have superior thermal, mechanical (e.g., hardness, elasticity, etc.) and chemical properties. They are understood by their composition, the nature of chemical bonds, and the microstructure. The selection of a material for a certain application is made depending on its physical, chemical, mechanical, electrical and thermal characteristics. Different materials and their properties are being discussed in the following sections.

31.1.1 Metals and Alloys

Metals are hard, rigid substances that are good conductors of heat and electricity. They are malleable and ductile and thus can be easily rolled into sheets or easily drawn into wires without fracture. These characteristics allow the use of metals in indoor construction and industries. Steel is utilized in bridges and can be found in several buildings due to its strength. Aluminum is utilized in the bodies of aircrafts, because it is light-weight, and copper is normally used into electric wires since it has amazing conductivity.

Metals are mostly found in the earth crust. Less reactive metals, such as gold and platinum can be found in the free state, i.e. they exist in the metallic state in nature and do not form compounds with other elements frequently. On the other hand, more reactive metals, e.g., sodium, aluminium, iron, copper, etc., exist in the combined state in the form of ores. For example, hematite (Fe_2O_3) is an ore of iron and it is found in certain parts of the world. Metal ores are distributed in the earth's crust in different quantities. Ores are not pure compounds, rather mixtures of the desired metal compound impurities, and earthly materials, which are called gangue. Such metals are extracted from their ores through a series of physical and chemical processes..

Extraction of Metals (Metallurgy)

Metallurgy is the science of extracting metals out of their ores and making them pure for better use.

The reactivity and the nature of the metal defines the extraction procedure.

Metallurgy involves a series of processes to finally obtain the purest form of a metal.

- i. **Mining** is the process of acquiring the metal ores that are buried deep in the earth. For example, iron ores.



Figure 31.2 Left; A view of the iron ore (haematite) mining, right; A lump of haematite



ii. **Ore Concentration** is the process in which the ore of a metal is made free from impurities as much as possible.

iii. **Conversion of concentrated ore to metal oxide.**

This can be done in two ways, mostly. The first method is roasting which involves heating a sulphide ore of a metal with excess supply of air.

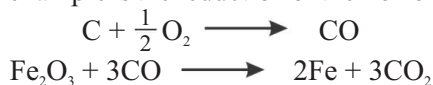


Another method is calcination in which a metal carbonate ore is heated in a limited or no air environment to convert it into its oxide.



iv. **Reduction of metal oxides to metal**

The reduction of metal oxides is the most important step of metal extraction. Different techniques are used for different metals depending on their reactivity. For less reactive metals (below carbon in the reactivity series), carbon is used as a reducing agent. Carbon is first converted into CO which then reacts with the metal oxide. Carbon monoxide displaces the oxygen from the metal oxide to form a free metal. An example is the reduction of the iron ore as follows:



However, the above method cannot be used for metals that are more reactive than carbon as carbon is not able to reduce their oxides. For such metals, an electrolytic method is used, which requires significant energy to melt the metal compounds and pass an electric current through them. This method is crucial for extracting highly reactive metals (e.g. Na, K, Al as they are not easily reduced with carbon), or for achieving very high purity in less reactive metals (e.g. Cu). The positive metal ions move to the negative electrode (cathode), where they gain electrons to form the metal.

v. **Refining the metal**

Most of metals have high percentages in the samples obtained after reduction. However, some metals need very high purity for special applications. For example, copper needs to be 99.99% pure in the electrical wiring. The final step is the purification to get the pure metal, which is then used for practical purposes. A metal can be refined by thermal, chemical or electrochemical methods.

vi. **Alloying of Metals**

Alloying involves the mixing of any two or more metals to give a homogeneous solution or mixing of a metal with a non-metal. This is done to alter the microstructure of the metal to enhance the properties, such as strength, corrosion resistance, and electrical or magnetic properties. Common alloys and their uses are provided in **Table 31.1**.

Table 31.1 Properties and uses of common alloys

Alloy	Constituent Elements	Properties	Common Uses
Brass	Copper (60-90%) + Zinc (10-40%)	Strong, corrosion-resistant	Electrical fittings



Bronze	Copper (88%) + Tin (12%)	Hard, wear-resistant	Medals, statues
Steel	Iron (98-99%) + Carbon (0.1-2%) (and other elements: Cr, Ni, Mn, Si, S)	Tough, durable, strong	Buildings, tools
Duralumin	Aluminium (93-95%) + Copper(3.5-4.5%) + Magnesium (0.4-0.7%) + Manganese (0.4-0.7%)	Lightweight, strong, corrosion-resistant	Aircraft body

31.1.2 Ceramics

Ceramics are hard but brittle materials that have high melting temperatures and very good insulating capabilities, which make them fit in high temperature and electrical applications. Chemically, they contain a blend of silicates and oxides of alkali and alkaline earth metals, and aluminium, such as K_2O , Na_2O , CaO , Al_2SiO_3 , etc. The strong bonds and fixed structures give ceramics unique and highly desirable properties such as strength, durability, and resistance to corrosion and heat. Due to these characteristics, they are useful in pottery, furnaces, tiles and sanitary ware (porcelain), windows and optical fibres (glass), spark plugs (alumina), etc. A summary of various properties of ceramics and their applications is provided in **Table 31.2**.

Table 31.2 Properties of ceramics and their applications

Property	Description	Application Example
High Melting Point	Remain solid at very high temperatures.	Refractory bricks lining steel furnaces.
Hardness and Wear Resistance	Extremely difficult to scratch or abrade.	Abrasives (e.g., silicon carbide in sandpaper) and cutting tools.
Electrical Insulator	Do not conduct electricity (most).	Porcelain insulators on power lines.
Chemical Inertness	Highly resistant to corrosion and chemical attack.	Ceramic coatings on chemical processing equipment.

31.1.3 Polymers

Polymers are large inorganic or organic molecules having unique properties. Although, organic polymers are much more common, inorganic polymers are essentially more significant in certain applications than organic polymers. Polymers are prepared from a variety of small molecules of choice. A detailed discussion on polymers is given in **Chapter 26**.

31.1.4 Composites

Composites are very efficient and useful modern day materials. A composite is a combination of two or more materials to form a product which has better properties.



One component is called the matrix, while the others, which are caged in the matrix, are called reinforcement agents. Some composites may have more than one reinforcement agent. An example is fibreglass, which is composed of a polymer as the matrix, and the reinforcement agent may be the fibres of a fabric, glass, or carbon-based materials. The matrix holds the reinforcement, whereas the reinforcement provides high strength to the material. Composites possess good strength to weight ratio and strong resistance to corrosion and are, therefore, suitable in demanding applications. As an example, boat hulls and car bodies are made of fibreglass, whereas carbon fibre is widely used in the aircraft and sports gear industry because of its lightness and strong durability.



Figure 31.3 Fibreglass is used for insulating walls and ceiling from heat and cold

31.1.5 Semiconductors

Semiconductors are substances conducting electricity only in special conditions and are light, heat, and voltage sensitive. Due to these characteristics, they are important in modern electronic applications. The difference between conductors and semiconductors is that the current passing through a semiconductor can be controlled as demanded in an application. The most common semiconductor is silicon, which is used in microchips and solar panels since it is highly effective and abundant. A mobile SIM card is composed of a silicon chip with some other minor components, such as copper connectors. Silicon can be used to conduct, store and process data in a device. Another major semiconductor is gallium arsenide (GaAs), which is used in wireless communication, e.g. 5G internet devices. Gallium nitride (GaN) is used in electric cars for fast charging due to its advanced conductivity.



Quick Check 31.1



- Why ceramics are used as insulators on power lines.
- Why is silicon preferred for use in microchips and solar panels?
- What do reinforcement agents provide in composite materials?

31.2 TOXICITY AND RECYCLING IN MATERIAL SCIENCE

31.2.1 Toxicity of Materials

Toxicity is the extent to which a substance can harm an organism or the environment. A material may be toxic during its production, use, and final disposal. The toxicity is measured by the extent and type of hazard that a material may cause. Hazards posed by a material are of many types. At first place are **health hazards**, i.e., a substance can cause damage to health upon exposure. For example, metals like chromium are carcinogens (cause cancer), mutagens (change DNA and genes), and cause respiratory issues. Another example is some additives in plastics, which can cause hormonal problems in the body.

Some materials can cause **physical hazards** due to their physical or chemical properties.



The physical cause may happen to buildings, humans, ecosystems, and the environment. For example, a flammable or an explosive material can harm humans, forests, or damage a building. **Environmental hazards** are by the substances that can cause long-term harm to aquatic life or the environment. **Heavy metals** like lead, mercury, and cadmium can leach into soil and groundwater. Heavy metals are dangerous to plants, animals on ground, as well as fish and other aquatic organisms.

31.2.2 Major Toxic Materials

Although, there are a number of toxic materials that are becoming the part of the environment. Plastics and heavy metals are two major concerns that are being discussed here as examples. These materials are commonly used due to their superior properties. However, their long-term effects are lethal.

Heavy Metals: Lead (Pb), mercury (Hg) and cadmium (Cd) are the common metals found in electronics, batteries, and fluorescent lights. They can get into the ground water from where they can transfer to the living organisms.

Plastics: A lot of plastics have toxic additives such as phthalates or bisphenol A (BPA), which can interfere with the hormones. Microplastics can now be found in oceans, soil, and even in food which has a long-term effect on the human lives and the ecosystems. In humans, microplastics are found to be carcinogenic (cancer-causing)

31.2.3 Recycling

Recycling is an important aspect of waste management, conservation of resources and energy saving. Yet, in materials science, modern materials are experiencing severe technical, economic, and environmental limitations to recycling and reuse. With more complex synthetic products, toxicity and sustainable disposal have become a rising concern.

Recycling minimizes the solid wastes in the landfills and preserves the limited natural resources such as metals, oil and timber. One of its other advantages is energy saving e.g., the recycling of aluminium consumes 95 percent less energy as compared to the recovery of aluminum by using the raw ore.

Challenges Associated with Recycling

The first challenge is material separation challenge. Most of the present day products (e.g., mobile phones, laptops) are assembled using mixed materials which are not easily separated, such as plastic coating on metals or multi layered packaging films.

The second major challenge to recycling is expensive reprocessing. Reprocessing waste involves sorting, cleaning, and other methods, therefore, it is usually expensive. Reprocessing of plastic, electronics, and other materials requires a lot of energy. Excessive use of energy is uneconomical, especially when these materials are available elsewhere at a lower price.

Most often, reprocessing results in the contamination of the product material, posing the contamination challenges. The recycled metals and plastics can be contaminated by dye, chemicals, or biological materials that decrease their quality and safety for reuse. In food-grade use, recycling of contaminated plastic is not possible.



Table 31.3 Principles and methods of recycling of some important materials

Material	Recycling Method	Chemical Principles/Focus
Plastics	Mechanical Recycling (Reprocessing)	Sorting, cleaning, melting, and reforming the plastic. Limited by contamination and degradation of polymer chains.
	Chemical Recycling (Depolymerization)	Breaking down the polymer chains into the original monomers or simpler chemicals using heat, solvents, or catalysts. This produces purer reactants.
Metals (Steel, Aluminum)	Thermal and Chemical Refining (Metallurgy)	Melting and refining processes to remove impurities. Requires significant energy, but much less than primary production.
Paper	Pulping and De-inking	Chemical and mechanical separation of fibres. Pulp is treated with chemicals (like NaOH or Na ₂ CO ₃) to remove inks and dyes.
Glass	Cullet Preparation and Melting	Cleaning, crushing, and melting the scrap glass (cullet) to form new glass. Chemically simpler as glass is a non-crystalline solid.

**Quick Check 31.2**

- Name two types of hazards caused by toxic materials.
- Which methods will you use for the recycling
 - empty metal food cans
 - empty beverage glass bottles
 - shopping bags and toys
- How do heavy metals enter the food chain?
- How does recycling help conserve natural resources?

31.3 X-RAY CRYSTALLOGRAPHY AND STRUCTURE ANALYSIS

X-ray crystallography is a very strong analytical tool used to identify three dimensional positions of atoms in a crystalline solid. It is important in material science, biochemistry, and pharmaceutical chemistry as it enables scientists to visualize material structures.

X-rays have very small wavelength. Therefore, this electromagnetic radiation can be used to find the position of electrons and atoms in a molecule or an ionic compound. The solid materials consist of layers or strands of atoms.



When the X-rays from the source fall on a crystal, they are diffracted after hitting the atoms at specific angles as shown in **Figure 31.4**.

These diffracted rays make patterns on a screen called the diffraction patterns. A diffraction pattern spots the location of atoms and electrons in a molecule. It also draws maps and determines the distance between atoms. With the help of mathematical models and the analysis of this pattern, scientists are able to draw a detailed map of atomic position and bond angles in the crystal. Thus, a complete pattern of atoms and their electron density can be mapped to determine the overall structure of the molecule or the crystal. The structure of the naphthalene molecule is presented in **Figure 31.5**.

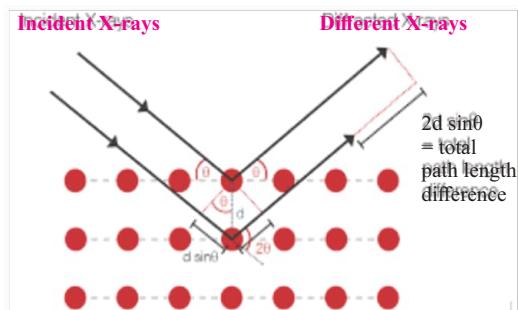


Figure 31.4 X-ray diffraction

The structure of the naphthalene molecule is presented in **Figure 31.5**.

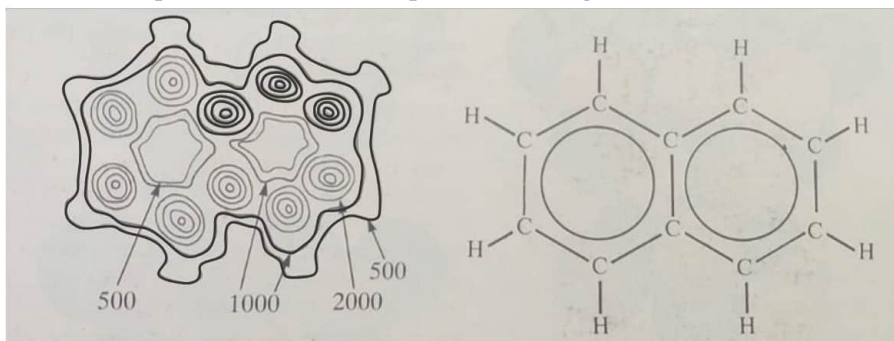


Figure 31.5 The diffraction pattern of the naphthalene molecule

The most well-known use of XRD is the determination of the double helix structure of DNA. The method of X-ray crystallography is still applicable in analyzing complex biomolecules like enzymes and proteins. It can also be used for pharmaceutical drug development. During the drug development designers employ this method to realize how a drug molecule attaches to its target. Another application is the analyses of materials and minerals. Here, it is used to analyze the minerals, synthetic crystals and nanomaterial. This is helpful to enhance material performance in the fields of electronics, optics and constructions.

31.4 FOSSIL FUELS

Petroleum (crude oil), coal, and natural gas are collectively called fossil fuels. Crude oil is mined at the underground reservoirs and refined in large size plants through fractional distillation. Major products from petroleum are naphtha, gasoline, kerosene and diesel.

Methane (CH_4) is the major component of natural gas, in mixtures with ethane, propane, and butane. Methane is mainly employed in the production of ammonia (used in fertilizers) and methanol (utilized in solvents and fuel). Coal is not as useful as it was before, but it still represents a petrochemical raw material, especially in areas where reserves are high. The primary use is to obtain benzene, toluene, and xylene that are vital in the manufacture of dyes, resins, and explosives.



Keep in Mind



Despite the fact that fossil fuels are highly efficient sources of energy, combustion of these products produces greenhouse gases such as carbon dioxide (CO_2) and others. This leads to air pollution, global warming, and climate change.

Table 31.4 Forms and uses of fossil fuels

Fossil Fuel	Main Uses
Petroleum	Transportation fuels (petrol, diesel), lubricants
Natural Gas	Cooking, heating, electricity, and fertilizer production
Coal	Electricity generation, cement, and steel industries

31.5 FRACTIONAL DISTILLATION AND REFINING OF PETROLEUM

Crude oil is a complicated mixture of hydrocarbons and it needs separation into simpler and useful hydrocarbons. This separation process is done physically by a method known as fractional distillation which depends on the difference in boiling points of different hydrocarbons. During this process, the crude oil is heated inside a furnace until it is vaporized. The vapor is then passed to a fractionating column, a tall tower through which the temperature drops slowly going up.

Since the vapor travels upwards, various hydrocarbon constituents condense at various points in the column based on their boiling points. Hydrocarbons that are heavier have higher boiling point are condensed closer to the bottom, whereas lighter hydrocarbons with low boiling point rises further. The process enables the extraction of useful fractions of crude oil which are given below with their uses in **Figure 31.6**.

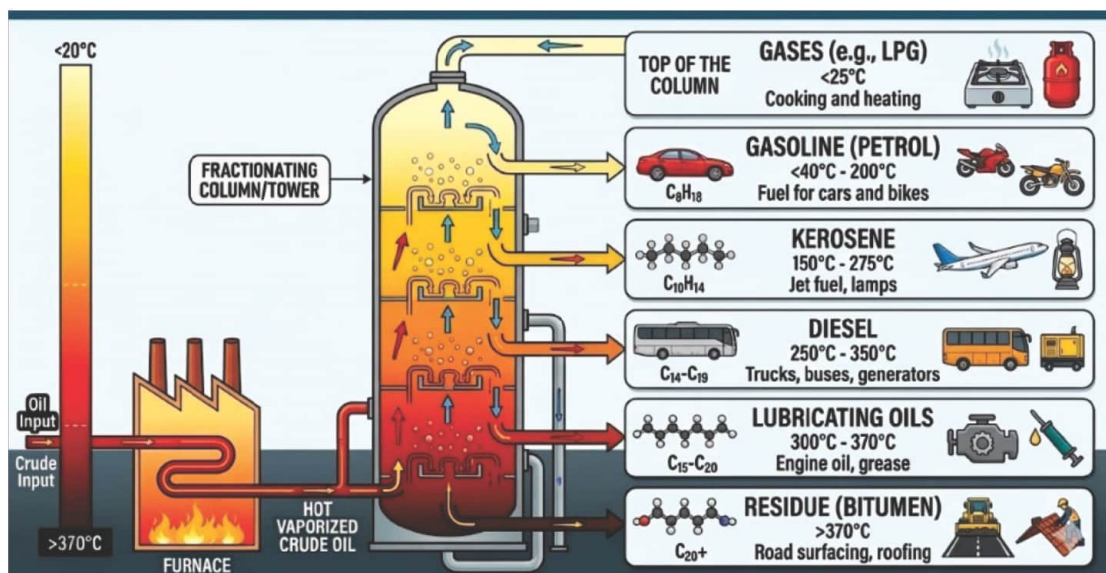


Figure 31.6 Fractional distillation of crude oil into useful hydrocarbons



Fractional distillation is an important process as it provides petrochemicals having applications in industries, domestic, and transportation purposes.



Quick Check 31.3



- If fossil fuels are non-renewable resources, why are they still heavily used worldwide?
- Can XRD be used to find the structure of liquid?

31.6 PETROCHEMICALS

Petrochemicals are compounds (chemicals) obtained primarily by means of crude oil and natural gas by refining and transformation. They are used to make diverse daily items found in several industries including packaging, construction, textile, electronics, and medical sectors.

Synthetic chemicals or substances manufactured from petrochemicals represent derivatives of petrochemicals and these are very important industrial products. The derivatives of petrochemicals are subjected to chemical transformation, such as polymerization, oxidation, or substitution to obtain materials of immense daily-life significance. Some petrochemicals, their derivatives, and their uses are tabulated in **Table 31.5**.

Table 31.5 Derivatives of petrochemicals and their uses

Petrochemical	Derived Chemical/Product	Uses
Ethene	Poly(ethene) (Plastic)	Bags, bottles, packaging
Propene	Poly(propene)	Containers, automotive parts
Benzene	Styrene → Polystyrene / Poly(phenylethene)	Disposable cups, insulation
Toluene	TNT (Trinitrotoluene)	Explosives
Xylene	Polyester Fibres	Textiles, clothing (fleece, jerseys), and upholstery.
Butadiene	Synthetic Rubber (e.g., Styrene Butadiene Rubber)	Tires, footwear

31.6.1 Petrochemical Process Technology

(a) Cracking

A chemical process involving the thermal dissociation of large hydrocarbons (typically a naphtha or heavy oils) molecules into smaller, more useful molecules, such as alkenes, is cracking. The process is necessary since ethene and propene, which are smaller in weight, are the major raw materials used in the production of plastics and artificial rubber. There are two primary methods used to achieve this: **Thermal Cracking** and **Catalytic Cracking**.

Thermal Cracking

This process is based on very high temperatures (usually between 450 °C and 750 °C) and high pressure to physically open the carbon-carbon bonds. Since no catalyst is involved, the process



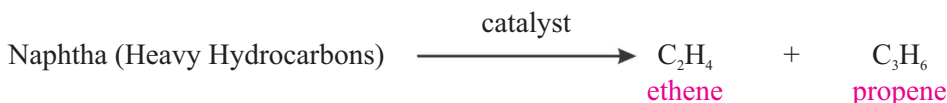
needs high energy input. It normally generates a high percentage of alkenes, which is important in the plastic industry. For example, a long-chain alkane, such as decane ($C_{10}H_{22}$) can be thermally cracked to produce octane and ethene:



Catalytic Cracking

Catalytic Cracking on the other hand is more efficient, and is more commonly used in modern refineries. This is done by adding a catalyst (usually zeolites (aluminosilicates) or silica-alumina), which reduces the activation energy of the reaction significantly. This enables the process to occur at reduced temperatures (approximately $500^\circ C$) and pressures, saving energy and better control over the final products.

One example is the cracking of a heavy fraction naphtha in the presence of a catalyst to produce high-demand petrochemicals. The reaction normally gives a blend of short chain alkenes:



b) Reforming

Reforming is a refining process that rearranges the molecular structure of hydrocarbons. In contrast to cracking (where the molecules are broken down), reforming rearranges straight-chain alkanes into a branched or cyclic (aromatic) structure.

The main purpose of reforming is to enhance the quality of fuel by converting low octane straight chains to high-octane branched or aromatic fuels to avoid engine knocking.

Reactions during reforming are given below:

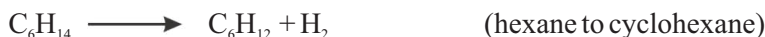
1. Isomerisation (formation of branched hydrocarbons)

The straight chain hydrocarbons are converted into branched-chain isomers of higher-octane numbers e.g.



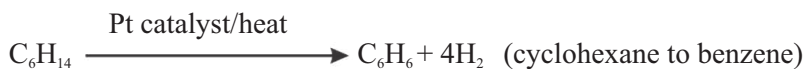
2. Cyclization (cyclic hydrocarbons formation)

Cyclic compounds are prepared by the conversion of straight-chain hydrocarbons e.g.



3. Dehydrocoupling (generation of aromatic hydrocarbons)

Hydrogen is lost by cycloalkanes to produce aromatic compounds. It is used to generate important chemical base materials e.g., BTX (benzene, toluene and xylene) that are the building blocks of plastics, dyes and synthetic fibres. For example, hexane, a straight 6-carbon chain is transformed into a stable aromatic ring, releasing hydrogen gas as a valuable byproduct.



**Quick Check 31.4**

- Why is catalytic cracking more commonly used in modern petroleum refineries?
- If more alkenes such as ethene and propene are desired to be produced from higher hydrocarbons, such as diesel or kerosene, which cracking method should be preferred and why?
- During reforming, hexane is converted into benzene and hydrogen. Explain why hydrogen can be considered a valuable by-product.

31.7 ENERGY DENSITY AND SPECIFIC ENERGY

When considering for different applications, there are two key aspects used to evaluate a fuel and must be kept under consideration; energy density and specific energy.

Energy density is the energy capacity of a substance, generally expressed by the quantity of energy that can be stored per unit volume of a fuel, typically in megajoules per liter (MJ/L). High-energy density fuels allow the use of a relatively small volume to store with large energy potential. These are useful in stationary applications and storage, e.g., in power plants, generators, etc. For example, diesel is more energy dense (~35.8 MJ/L) in comparison to gasoline (~34.2 MJ/L), i.e., it contains more energy per liter.

Specific energy can be defined as the amount of energy contained in a mass. It is typically measured in megajoules per kilogram (MJ/kg). It is an important measure in cases where weight is critical such as aviation or spacecraft mobile applications. A high-specific energy fuel will give significant amounts of energy, without contributing much mass. For example, hydrogen gas has extremely high specific energy (120 MJ/kg) that makes it potentially interesting in aerospace applications, although its energy density is low.

**MORE INFO****Interesting Information**

Compressed Natural Gas (CNG) used in the transportation sector in Pakistan is very economical. It has, however, lower energy density, which implies that vehicles need to carry more storage volume to carry enough fuel when compared to petrol. That is why CNG is suitable as a means of local commuting, and it is not perfect as a long traveling means

31.8 NUCLEAR ENERGY – FISSION AND FUSION

While studying fossil fuels and their harmful effects on the environment, it is also important to learn about **nuclear energy**. Nuclear energy is a potential and promising source of power that can help meet the world's growing energy needs. Nuclear energy is the energy that is released by nuclei of an atom, either when heavy nuclei are split (fission) or when light nuclei are combined (fusion). These reactions liberate extremely high quantities of energy as compared to chemical reactions.





Did You Know?

There was a great earthquake and tsunami in Japan, which triggered reactor accidents at Fukushima in (2011). More than 150,000 citizens were evacuated as a result of radioactive leaks, and the world became concerned about the safety of nuclear plants in disaster-prone regions.



Nuclear Fission

Fission is the process in which a heavy atomic nuclei like uranium-235 or plutonium-239 is split into two lighter atomic nuclei with energy production, generation of neutrons and radiations. Neutrons produced can also lead to additional fission in a chain reaction.

The nuclear reaction between uranium-235 and a neutron is as follows.



Nuclear power plants extensively use nuclear fission to produce electricity. It has a very high energy production using small quantities as input; however, it has serious drawbacks, too. It produces radioactive waste which should be handled with care over a long duration. There is also the danger of nuclear accidents, the consequences of which have been observed in history, such as the Chernobyl catastrophe (1986) and the Fukushima accident (2011). These accidents seriously affected the environment and human health negatively.

Solar Energy and Photovoltaic Cells

Solar PV (photovoltaic) system is a clean energy system where the solar panels that are typically composed of silicon semiconducting materials convert the energy of sunlight into electricity via photovoltaic effect. The exposure of the solar panel activates electrons in the material that produces the direct current (DC) electricity. This DC electricity is then converted to alternating current (AC) by an inverter and can be used to power homes, schools, offices and in industries. The system also has batteries to store electricity to use at night or cloudy days, and also assist in stabilizing voltage, and producing surge current. Other elements like electrical accessories, wires, appliances, and mounting structures make the entire solar energy system effective and safe.

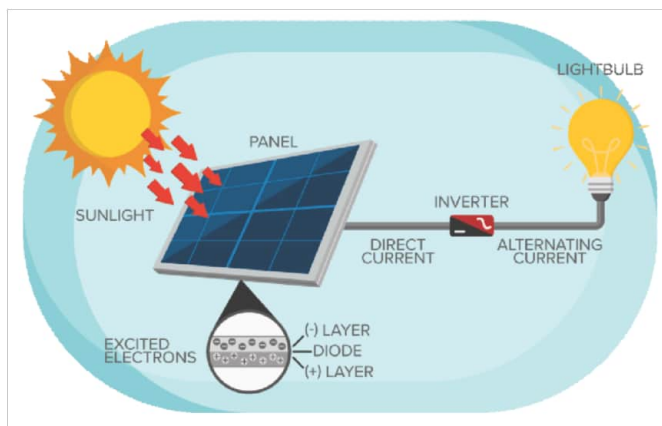


Figure 31.7 Working of solar panels



Solar energy has many key advantages over the traditional sources of energy. It is an environmentally friendly and renewable energy source. Therefore, it contributes to the fight against climate change and environmental pollution. Solar panels are also cost-effective in the long run, since they have limited maintenance requirements once installed.

Energy shortages, high fuel prices, and climate problems show that we need to switch to renewable energy sources like solar, hydro, and wind energy.



Quick Check 31.5



- Why are **batteries included** in many solar energy systems?
- Besides power generation, where else is nuclear fission used?
- Identify the missing component in the reaction:

$$^{235}\text{U} + \text{n} \rightarrow \underline{\hspace{1cm}} + \underline{\hspace{1cm}} + 3\text{n} + \text{energy}$$
- Why do nuclear reactions release much more energy than chemical reactions?

Exercise



Q1. MULTIPLE CHOICE QUESTIONS

I) A mining engineer discovers a new deposit of a metal that occurs primarily as a carbonate. Which sequence is most efficient for the extraction of metals?

- Mining, Concentration, Roasting, Reduction with Carbon
- Mining, Concentration, Calcination, Reduction
- Mining, Concentration, Electrolysis
- Mining, Roasting, Refining

II) The extraction of aluminium from its oxide is done by electrolysis and not by calcination because:

- | | |
|---|----------------------|
| a) Carbon forms alloy | b) Low melting point |
| c) Aluminium is more reactive than carbon | d) Removes gangue |

III) Which property makes ceramics suitable for furnace bricks?

- | | |
|-----------------------|----------------|
| a) Conductivity | b) Low density |
| c) High melting point | d) Flexibility |

IV) In fiberglass, the matrix mainly:

- | | |
|------------------------|-------------------------|
| a) Provides strength | b) Conducts electricity |
| c) Holds reinforcement | d) Increases weight |

V) Major limitation of mechanical recycling is:

- | | |
|----------------------|------------------------------------|
| a) High energy use | b) Polymer degradation |
| c) Monomer formation | d) use of Na_2CO_3 |

VI) The mobile phone recycling is difficult because of:

- | | |
|-------------------------------------|-----------------------|
| a) Non-recyclable material | b) Mixed materials |
| c) No heat sensitivity of materials | d) High melting glass |



VII) Chemicals from coal used in dyes are:

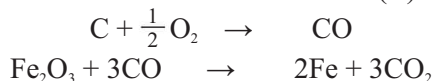
- a) Methane series
 c) Alkenes
 b) Benzene, toluene, xylene
 d) CO₂ and H₂

VIII) Nuclear fission involves:

- a) Combining nuclei
 c) Breaking bonds
 b) Splitting nuclei
 d) Molecules

Q2. SHORT ANSWER QUESTIONS

- a) What is a chain reaction in nuclear fission?
 b) State the economic challenge associated with reprocessing waste materials.
 c) Keeping in view the concept of microstructure, explain why adding zinc to copper (to form Brass) results in a material that is stronger than pure copper.
 d) Define energy density and give one example.
 e) Name two specific semiconductors mentioned in the text and their modern applications.
 f) State two applications of X-ray crystallography in science or industry.
 g) State two advantages and one disadvantage of nuclear fission.
 h) In the reduction of Hematite (Fe₂O₃), carbon is added, but carbon monoxide (CO) is the actual species that displaces the oxygen. Explain why the gas (CO) is a more efficient reducing agent in a large-scale furnace than solid carbon (C).

**Q3. CONSTRUCTED RESPONSE QUESTIONS**

- a) Explain environmental problem, caused by fossil fuels.
 b) Based on the chemical equations provided, explain why roasting sulphide ores poses a greater environmental challenge compared to the calcination of carbonate ores.
 c) If a sample of copper is 98% pure after reduction, why is the final "refining" step still considered crucial for the manufacturing of electrical wiring?
 d) Explain, why chemical recycling (depolymerization) is often superior to mechanical recycling?
 e) Gold is often found in its free state, while sodium is only found in the combined states. Use the concept of the reactivity series to justify why the extraction process for sodium is significantly more energy-intensive than for gold.

DESCRIPTIVE QUESTIONS

- Q4. Explain composite materials by describing and differentiating the roles of the matrix and the reinforcement in them.
 Q5. Explain how X-rays interact with crystals to produce diffraction patterns and how these patterns help determine atomic positions.
 Q6. Describe the main steps involved in the extraction of metals from their ores.



32

MEDICINE, AGRICULTURE AND INDUSTRY

Student Learning Outcomes

[C-12-E-50 to C-12-E-65]

Part I MEDICINE

- Recognize the concept of therapeutic index and therapeutic window in relation to drug administration.
- Describe the pH regulation of stomach and its relation to the concept of non-specific reactions and active metabolites.
- Explain the mechanism of action and uses of aspirin and penicillin and explain the chemical structure of the same.
- Describe the mechanism of action of opiates and the concept of opioid receptors in the brain.
- Recognize the challenges in treating viral infections with drugs and the concept of antiviral medications.

Part II AGRICULTURE

- Explain the chemical composition and function of different types of fertilizers, including their role in providing essential nutrients to crops and the impact of their application on soil health.
- Identify the different types of pesticides used in agriculture and describe their mode of action, including the potential benefits and risks associated with their use.
- Identify the chemical reactions that occur when acid rain falls on crops and soil and explain the effects it has on crop growth, including nutrient uptake and crop yield.
- Explain how changes in temperature, precipitation, and extreme weather events can affect crop growth and yield, including the potential for crop failures and food shortages, as well as the potential to develop new crop varieties that are more resilient to changing climate conditions.
- Explain the basics of genetic engineering and how it is used in agriculture, including the development of genetically modified crops and the potential benefits and risks associated with their use.

Part III INDUSTRY

- Justify the importance and significance of industrial chemistry in various industries such as manufacturing, energy, healthcare, and environmental protection.
- Identify the raw materials and resources used in industrial chemistry, including those readily available in the context of Pakistan.
- Discuss the importance of chemical industries in the economy of Pakistan, and describe the raw materials that are available in the country for various chemical industries.
- Describe the chemical processes involved in industrial production, including addition and condensation polymerization, and the properties and materials.
- Explain the applications of industrial chemistry in industries such as petrochemical, cosmetics, cement, food production and more.
- Elaborate on the safety measures and precautions necessary in industrial chemical processes and facilities.



Medicines prepared in the pharmaceutical industry are of vital significance as regards human health. Chemistry unlocks the secrets behind how drugs truly work inside the body. A drug's safety limits and optimal dose range are two very crucial aspects of medicine. The knowledge of safety and the action of a drug ensures the safe absorption and action of a drug on the target disease. In this chapter, these aspects will be discussed.

32.1 THERAPEUTIC INDEX AND THERAPEUTIC WINDOW

Pharmacology is the science which deals with, what a drug does and the safety margins within which it operates. Every drug may be a potential poison; the difference lies in the dose of each drug. The therapeutic index and therapeutic window are central concepts for understanding how safe and effective a medicine is. They help doctors to determine the right amount of a drug to give to a patient.

32.1.1 Therapeutic Window

Therapeutic window is the range of drug concentrations in the plasma that are effective without causing harmful side effects. It is the "sweet spot" of medicine i.e. not too less to be ineffective and also not too high to be dangerous.

Minimum effective concentration (MEC) is the lowest dose of the drug below which it fails to produce a clinical effect. Minimum toxic concentration (MTC) is the lowest dose at which drug begins to cause adverse effects or "poisoning". Duration of action is the time duration in which the drug concentration remains within its therapeutic window.

A wide therapeutic window indicates the safety limits of a drug, as there is a large gap between the dose that works and the dose that's harmful. This allows more flexibility in dosing. A narrow therapeutic window means the drug is less safe because the effective dose is very close to the toxic dose. Doctors must be extremely careful when prescribing these drugs and often need to check the patient's blood to ensure the drug level stays within the correct narrow range.

The simultaneous use of multiple medicines, genetic factors, obesity, age, or overall health may also affect the therapeutic window of the drug. All these factors govern the metabolism and efficacy of a drug.

32.1.2 Therapeutic Index

The therapeutic index (TI) is a quantitative measurement of a drug's safety. It compares the dose that causes a toxic effect to the dose that produces a desired therapeutic effect. A higher TI means the drug is safer because there's a larger difference between the effective dose and the toxic dose. A low TI means the drug is more dangerous and requires careful monitoring to avoid toxicity.

TD_{50} (Toxic Dose 50) is the dose that causes a

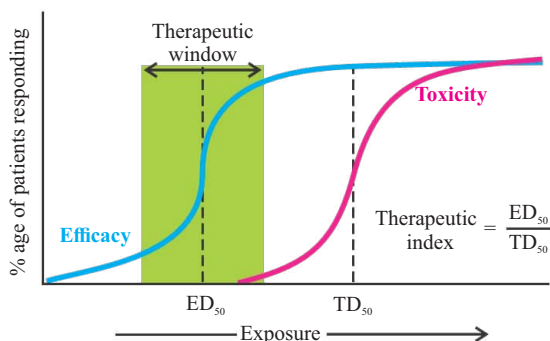


Figure 32.1 Therapeutic window and therapeutic index illustration



toxic effect in 50% of the people who take it. For example, a drug with a TI of 10 is much safer than one with a TI of 2. ED_{50} (Effective Dose 50) is defined as the dose that works for 50% of the people who take it.

Drugs like Penicillin or Paracetamol have high TI. It means if patients accidentally double their dose, this will not put a potential threat to their lives. On the other hand, drugs like Warfarin (a blood thinner) or Digoxin (heart medicine) have to be taken very carefully only in proper dosage. Otherwise, they may risk the life of the patient. Patients using low TI drugs must carry regular blood tests for therapeutic drug monitoring (TDM).



Did You Know?

Before modern blood-level monitoring, Digoxin was a frequent cause of accidental hospital deaths. Because, its TI is so low, even minor interactions with common foods or other drugs would push patients into a lethal "toxic zone." Its toxicity causes ventricular fibrillation (a fatal heart rhythm) and "yellow-tinted" vision (xanthopsia).



32.2 IMPORTANCE OF pH IN STOMACH

The stomach has a highly acidic environment with a low pH (1.5–3.5). This acidity is regulated by parietal cells, which actively pump hydrogen ions (H^+) into the stomach. This process is important for digesting food and killing bacteria. Although the stomach has very low pH but it protects itself via a thick layer of mucus and bicarbonate ions, which neutralize acid at the cell surface. The low pH of stomach can cause non-specific reactions, meaning it can chemically change some drugs. For example, some drugs may break down in the acidic environment before they can be absorbed into the bloodstream. This is why some medications are given in a protective coating that only dissolves in the less acidic small intestine.

32.3 MECHANISM OF DRUG ACTION

The mechanism of action is how a drug works at a cellular level to produce medical effects. Here we shall discuss two famous medicines i.e., aspirin and penicillin along with their mechanism of drug action. The action of aspirin in blocking COX enzyme has already been discussed in Chemistry XI (chapter 3). Here we will discuss mechanism of action of penicillin.

32.3.1 Penicillin

It is a powerful antibiotic used to treat many types of bacterial infections, such as respiratory infections like, strep throat, pneumonia, scarlet fever and sinusitis. It also helps to treat skin and soft tissue infections like cellulitis, erysipelas.

The structure of Penicillin contains two core rings; a four-membered beta-lactam ring and a five membered thiazolidine ring. Both the rings have certain side chains attached to them. The beta-lactam ring is crucial for the antibiotic's activity, as it is

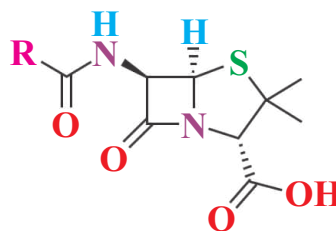


Figure 32.2 Chemical structure of Penicillin



the site where bacterial enzymes called beta-lactamases can attack and deactivate penicillin.

The structure of penicillin looks identical to the amino acid sequence of the enzyme which strengthens the cell wall. The enzyme mistakenly takes up penicillin molecule, where the beta-lactam ring opens and bind permanently to get inactivated. Bacteria continue to grow, but without the functional cell wall, and eventually burst to die. Since human cells don't have cell walls, penicillin does not harm our cells.



Did You Know?

In 1928, Alexander Fleming accidentally discovered penicillin when he noticed that mold growing on a contaminated petri dish had killed surrounding bacteria. The mold, later identified as *Penicillium*, released a substance that inhibited bacterial growth. This chance observation led to the development of the first antibiotic, revolutionized modern medicine.



32.3.2 OPIATES AND OPIOID RECEPTORS

Opiates are a class of drugs that come from the opium poppy plant. They are powerful pain relievers but also cause addiction. The legal drugs include the morphine, codeine, oxycodone, hydrocodone etc. The illegal category contains drugs like heroin, fentanyl etc.

Concept of Opioid Receptors

The human brain produces our own painkillers called endorphins. These bind with opioid receptors in our Central Nervous System (CNS). Opiates "hijack" this natural system, and become effective for pain relief but also highly addictive.

There are three types of opioid receptors. Mu (μ) receptors are located in the brain and spinal cord. These are primary target for most of the opioids like morphine. They are responsible for analgesic activity of opiates, but activation of these receptors can also cause respiratory depression and intense euphoria. Kappa (κ) receptors are involved in spinal analgesia and sedation; but they are less associated with euphoria. Delta (δ) receptors play a vital role in emotional response and mood regulation.

Mechanism of Action

Opiates work by binding to special proteins in the brain and spinal cord called opioid receptors. It works like a key (opiate) and lock (receptor) model. When the opiate binds to the receptor, it blocks pain signals from reaching the brain, making the person feel less pain. In actual, when an opiate binds the receptor, it closes the calcium channels and opens the potassium channel. This hyperpolarizes the neuron, making it much harder for the cell to send the pain signal. It has been experimentally found that opiates trigger a neurochemical reaction in the reward center of brain, leading to excessive release of dopamine, which give a sense of relief and well-being.

Opioids are used to relief acute pain like sudden and short-term pain. They are also used to manage the severe pain associated to cancer. Opioids like codeine is used in cough syrups as they suppress the cough reflex. They bind to the receptors in gastrointestinal tract, slows down digestion and can alleviate diarrhea.





Did You Know?

Before it became a street drug, Heroin (diacetylmorphine) was a trademarked medicine sold by Bayer as a "non-addictive" alternative to morphine and a cough suppressant for children. Because its potency is roughly five times that of morphine, it crossed the blood-brain barrier faster, creating a "rush" that led to a global addiction epidemic.



32.4 CHALLENGES IN TREATING VIRAL INFECTIONS

Treating viral infections is fundamentally different from bacterial treatment. Bacteria are independent organisms, while viruses are parasites. Unlike bacteria, which are living organisms on their own, viruses are not truly alive. Viruses live inside our cells and use our own DNA/RNA machinery to replicate. This makes it hard to develop a drug that kills the virus without harming our healthy human cells.

Viruses can change their genetic material very quickly. This is called mutation. A drug that works against a virus one year might not work the next because the virus has changed. This is why flu vaccines need to be updated every year.

Viruses also integrate into our genome and stay asleep for years. Drugs at recent times can kill only active viruses and not those which have been sleeping for years.

Antiviral medications work by targeting specific stages of the viral life cycle. For example, some antivirals prevent the virus from entering our cells, while others stop the virus from making copies of its genetic material. One of the most common mechanisms of action of antiviral drugs is enzyme inhibition. For example, protease inhibitor, does not allow the virus to produce their protein in one long strand. These inhibitors also help in the treatment of HIV and hepatitis C infections. Some antiviral drugs enhance the immune response to viral infections. Interferons are proteins that can boost immune system to fight against viruses.



Quick Check 32.1



- Drug A has a TI of 3, and Drug B has a TI of 50. Which drug is considered safer, and why?
- How do antacids (e.g., magnesium hydroxide, $Mg(OH)_2$) chemically regulate stomach pH? Write a simple neutralization equation to illustrate this.
- Identify the core, strained heterocyclic ring system in penicillin that is essential for its antibacterial activity.
- Compare the chemical structures of morphine and codeine (methyilmorphine). How does this small structural difference relate to codeine's action as a prodrug?
- Why do many antiviral drugs cause significant side effects for the host patient?

AGRICULTURE

In this section, we shall explore the role of chemistry in modern agriculture. Here we shall discuss the importance and role of fertilizers, pesticides, genetic engineering to increase the supply for growing demand of food due to increase in world population. The section will also describe the chemical reactions of acid rain on crops and soil and explains how climate change affects crop growth.



32.5 FERTILIZERS

Fertilizers are the mineral rich superfood given to the soil which improves its fertility. They replenish the depleted soil and boost healthy growth, increase crop yields, and ensure better food production. Fertilizers are chemicals that provide essential nutrients to plants to promote growth and increase crop yields. Synthetic fertilizers are man-made through chemical processes like the Haber-Bosch process for ammonia (NH_3). Organic fertilizers come from natural sources like compost or animal manure.

Plants require seventeen essential elements, as micronutrients and macronutrients. The micronutrients include boron, iron, copper, chlorine, manganese, molybdenum and zinc. Whereas the macronutrients are carbon, hydrogen, oxygen, nitrogen, phosphorus, sulphur, potassium, calcium and magnesium. Out of these nine macronutrients nitrogen, phosphorus, and potassium are needed in such large quantities that they are termed primary macronutrients. Commercial fertilizers are labeled with an N-P-K ratio, which represent the concentration of these three elements.

Role of Fertilizers in Plant Growth

1. **Nitrogen:** Nitrogen is often the most limiting factor in crop production. It is a fundamental component of amino acids, which build proteins, and chlorophyll, the pigment responsible for photosynthesis.
2. **Phosphorus:** It is typically supplied as superphosphates or ammonium phosphates. Phosphorus is a structural component of ATP (adenosine triphosphate) which stores and releases energy.
3. **Potassium:** Unlike nitrogen and phosphorus, potassium does not become part of the plant's physical structure. Instead, it acts as an osmoregulator. It also activates over sixty different enzymes that facilitate plant metabolism.

When applied, these chemicals are taken up by plant roots. However, if too much is used, the excess can wash away into rivers and lakes, causing an overgrowth of algae, which is harmful to aquatic life. Long-term use of some synthetic fertilizers can also change the soil's pH and kill beneficial microorganisms, hurting soil health.



Did You Know?

Why farmers rotate crops? Growing the same crop every year depletes the same nutrients. Crop rotation restores soil nutrients and reduces the need for synthetic fertilizers.



32.6 PESTICIDES

Pesticides are chemicals used to kill or control pests like insects, weeds, or fungi. Pesticides protect crops from damage, preventing food loss and ensuring a stable food supply. They are classified by their target pest into insecticides, herbicides and fungicides.

Insecticides are the chemicals which control the insects by targeting their nervous system. Many modern insecticides like organophosphates or neonicotinoids act as neurotoxins, which damage the nervous system of insects leading to paralysis and death.



Neonicotinoids have been reported to be linked to “Colony Collapse Disorder” in honeybees, threatening global pollination.

Herbicides are the chemicals which control unwanted, competitive plants called weeds. Some herbicides cause enzyme inhibition, and do not allow synthesis of essential amino acids. Whereas, some of them, disrupt electron transport and prevent weeds from performing photosynthesis.

Fungicides kill the fungus by targeting their cellular integrity. They target ergosterol synthesis in fungal cell membranes, and without a stable membrane, the fungal cell leaks and dies. The most common examples are triazoles, strobilurins, zinc phosphide etc.

Pesticides are playing a pivotal role in modern food development programs. They help to protect plants from pests and diseases and enhance the yield of crops. They reduce the risk of epidemics and improve human health as well. They also contribute in food security and stability worldwide. Pesticides can cause adverse health effects being carcinogenic and neurotoxic. Beneficial insects, birds and aquatic organism can also be affected by pesticides. Runoff water from fields can contaminate water sources and harm aquatic organisms. Pesticides can harm non-target species like pollinators (e.g., bees) which play a key role in pollination of many crops. Overtime, pests can develop immunity against certain pesticides, making them less effective. This forces us to use more toxic pesticides, which may pose further adverse environmental and health issues.

32.7 ACID RAIN

Acid rain is an atmospheric mixture of nitric acid and sulphuric acid produced by industrial pollution. Normal rain water has pH up to or above 5.6, due to carbonic acid. If it has a pH lower than 5.6, it potentially becomes the acid rain.

Acid rain is caused due to sulphur oxides (SO_x) and nitrogen oxides (NO_x) in the atmosphere. These gases, often from industrial pollution, react with water to form sulphuric acid (H_2SO_4) and nitric acid (HNO_3).



When acid rain falls on soil, it causes a chemical reaction that leaches out essential nutrients like calcium (Ca^{2+}), magnesium (Mg^{2+}), and potassium (K^+) from the soil, making them unavailable for plants.



Simultaneously, it can increase the solubility of toxic metals, like aluminium (Al^{3+}), which can then be absorbed by the plants' roots and damage them. This reduces the plants' ability to take up nutrients, leading to slower growth and lower crop yields.



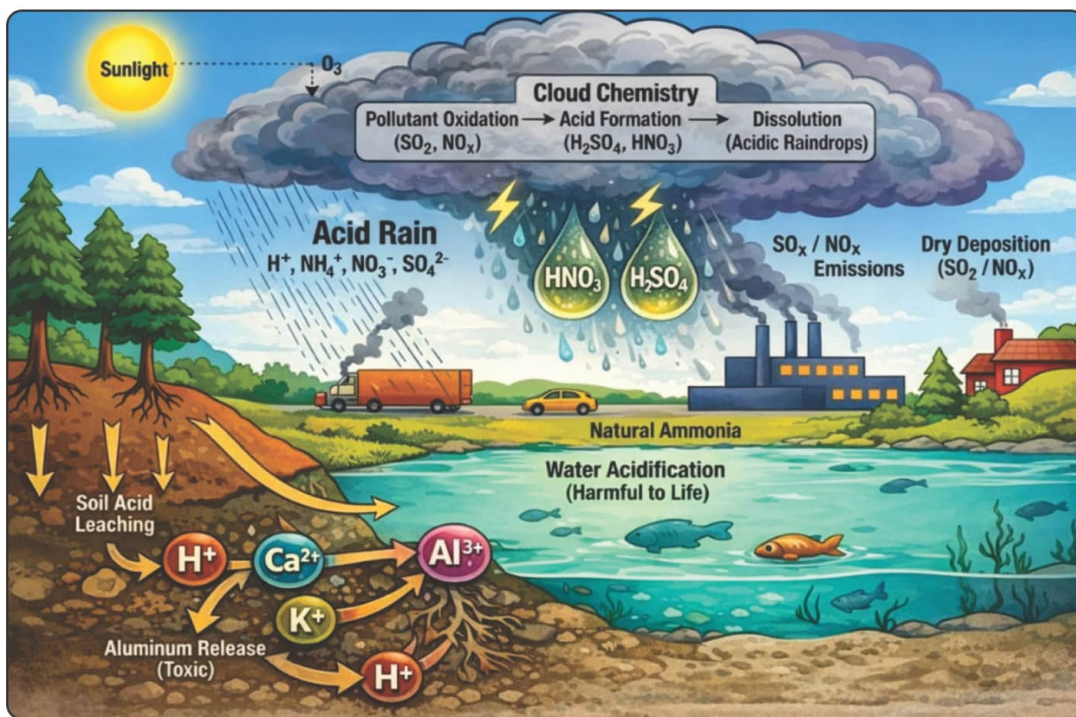


Figure 32.3 Effects of acid rain on agriculture

Direct acid rain can damage the leaves, dehydrate them and makes the plant vulnerable to disease and environmental effects. Acid rain can reduce the soyabean and wheat yields by reducing nitrogen fixation and nutrition intake. Acid rain can adversely affect the soil microbial communities, and disrupt the natural nutrient cycles and decomposition of organic matter.



Did You Know?

Why fish die in acidic lakes? Acid rain releases Al^{3+} from soil, which clogs fish gills and reduces oxygen absorption \rightarrow fish suffocate.

32.8 EFFECT OF CLIMATE CHANGE ON CROPS

Agriculture is the industry that is most vulnerable to shifting climates. Changes in temperature, precipitation, and extreme weather events due to climate change directly impact agriculture. Heat stress causes dehydration, which ultimately results in poor photosynthesis and respiration. Higher temperatures can speed up a plant's metabolism, but if they get too hot, plants suffer from heat stress, reducing their growth and yield. Similarly, cold climate also damages certain crops. It is fatal to young plants resulting in complete yield loss.

Normal rain helps plants by providing adequate amount of water and nutrients required for their healthy growth. However, changes in rainfall patterns can lead to drought in some areas and floods in others, both of which can cause crop failure. Unpredictable rains, cloud bursts can cause soil erosion, takes the nutrient-rich top soil away.



Events like hurricanes, heatwaves, and hailstorms can destroy crops and agricultural infrastructure, leading to food shortages. Storms can cause uprooting and branch damage. Strong winds cause water loss and can cause drought. Hails damage the leaves, fruit, stems, causing tissue damage, which result in poor photosynthesis. Severe hailing can cause total loss of yield by crop destruction. Higher UV-index and heat waves can put crops under severe heat stress, which speed up the water loss, may also result in leaf burning.

To adapt these changes, scientists are developing new crop varieties that are more resilient to different climates, for example, by creating drought-resistant corn or heat-tolerant wheat. Some drought tolerant and flood-proof traits have also been developed. For example, “Sub1 rice” which can survive being submerged underwater for two weeks.

32.9 GENETIC ENGINEERING

Genetic engineering in agriculture involves changing an organism's DNA by adding, removing, or modifying specific genes. This is used to create genetically modified (GM) crops with desired traits.

Scientists identify a useful gene (e.g., for pest resistance from a bacterium) with a desired trait, such as drought tolerance etc.

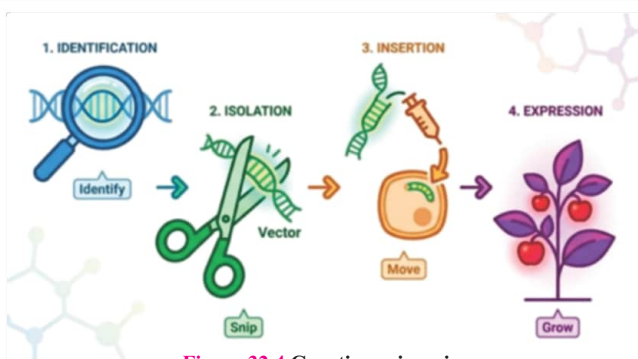


Figure 32.4 Genetic engineering

The gene responsible for a specific trait is isolated from the organism. The isolated gene is inserted into the target plant's genome by using a gene gun or a carrier bacterium to sew that gene into the plant's DNA. This new gene is then expressed by the plant's cells, giving it the new trait. The modified plant now produces new protein that it could not produce before.

GM crops can have improved resistance to pests and diseases, tolerance to herbicides, and enhanced nutritional value. This can increase crop yields and reduce the need for certain pesticides. For example, BT-Cotton produces its own pesticide, reducing the need for chemical sprays. Golden Rice is engineered with beta-carotene to prevent blindness in developing nations. Concerns include the potential for GM genes to spread to wild plants (outcrossing), the development of "superweeds" where herbicide-resistant genes jump from GM crops to wild weeds via cross-pollination, making them impossible to kill. It also produces resistant insects, and the long-term effects on human health and biodiversity.



Quick Check 32.2



- State two major agricultural benefits of using fungicides, linking to crop health or yield.
- Write the balanced chemical equation for reaction that occurs when powdered limestone (CaCO_3) is added to a lake or field to neutralize sulphuric acid (H_2SO_4) from acid rain.
- Identify two specific traits (e.g., heat tolerance, salt tolerance) that scientists aim to develop in new crop varieties to make them more resilient to climate change.



INDUSTRY

Industrial chemistry is crucial for the economy and daily life. This part of the chapter justifies its importance in sectors like manufacturing and energy and identifies key raw materials, especially those available in Pakistan. It describes essential industrial processes such as polymerization and their applications in industries like petrochemicals, cosmetics, and cement. The section concludes by emphasizing the vital safety measures required in chemical processes and facilities.

32.10 RAW MATERIALS IN PAKISTAN

Pakistan has several raw materials that are important for its chemical industries. The feedstock of an industry determines its location and economic viability.

Air provides nitrogen for fertilizers and oxygen for steel manufacturing. Water is used as a solvent, a cooling agent, and a source of hydrogen. Fossil fuels like coal, oil, and natural gas provide the hydrocarbons required for 90% of organic chemicals.

Pakistan possesses a unique geological profile that supports several chemical sub-sectors like:

- 1. Natural Gas:** It is a major source of methane (CH_4), used to produce fertilizers (urea) and petrochemicals. It serves as both a fuel and a source of hydrogen.
- 2. Rock Salt (Khewra Mines):** Khewra mines are one of the world's largest rock salt deposits. It is the source of sodium chloride (NaCl) for a raw material for Soda ash (Na_2CO_3), caustic soda (NaOH), and chlorine.
- 3. Limestone:** Limestone is highly abundant in salt range and Sindh. It is a source of calcium carbonate (CaCO_3) for the cement industry.
- 4. Gypsum:** It is used in the cement industry and for making plaster. It is also used as a source of calcium and sulphur and employed as a soil conditioner.
- 5. Chromite:** It is found in Muslim Bagh, and is used in stainless steel and pigment production.
- 6. Crude Oil:** It is refined to produce a wide range of fuels and petrochemicals.
- 7. Sulphur:** Sulphur is used to make sulphuric acid (H_2SO_4), a key industrial chemical.



Did You Know?

Pakistan has abundant natural gas, the main raw material for making urea (NH_2CONH_2). Because raw material is locally available, production costs are lower making fertilizers more affordable for farmers.



32.11 CHEMICAL INDUSTRIES AND PAKISTAN'S ECONOMY

The chemical industry is vital to Pakistan's economy, contributing significantly to its Gross Domestic Product (GDP) and providing jobs. It supports other major sectors like agriculture (through fertilizers), construction (through cement), and textiles (through dyes and synthetic fibres). The chemical industries use the country's locally available raw materials, such as natural gas, rock salt, limestone, and crude oil, to produce key products, which reduces reliance on imports. As an agrarian economy, Pakistan's food security depends on the chemical industry. Local



companies utilize natural gas to produce urea. This reduces the national import bill by billions of dollars. Textiles account for over 50% of Pakistan's exports. This industry is a massive consumer of caustic soda for mercerizing cotton, synthetic dyes to provide colour and fastness and hydrogen peroxide for bleaching fabrics. Due to infrastructure projects and urbanization, the cement industry has become a leading exporter to neighboring regions.

32.12 INDUSTRIAL CHEMICAL PROCESSES

Chemical manufacturing relies on two main pillars, reaction engineering and separation technology. Industrial production uses several key chemical processes. Some of them are:

- 1. Polymerisation:** This is a process where small molecules called monomers link up to form large chains called polymers. Addition polymerisation in which monomers add to one another without losing any atoms (e.g., ethylene monomers forming polyethene). Condensation polymerisation in which monomers join together and release a small molecule, usually water (e.g., monomers forming polyesters). Engro Polymer and Chemicals is the sole producer of Polyvinyl Chloride (PVC) in Pakistan.
- 2. Refining and Reforming:** In refining process, fractional distillation separates crude oil into different products based on their boiling points. The most important fractions include gasoline, diesel, kerosene etc. Reforming is the conversion of straight chain hydrocarbons to branched hydrocarbons to enhance the quality of fuel. During catalytic reforming, hydrocarbons are heated with catalyst to obtain a high-octane number gasoline. While often categorized as “Oil and Gas” the chemical cracking and reforming processes at refineries like PARCO and Attock Refinery provide essential petrochemical feedstocks for wider chemical industry.
- 3. Haber-Bosch Process:** In Haber process ammonia (NH_3) gas is synthesized from nitrogen (N_2) and hydrogen (H_2) gases. Iron metal crystals are used as catalyst in this process. This process contributes the 13% of the nitrogen fixation being done on the earth, as 70% of ammonia is utilized directly into fertilizer manufacture. Large-scale plants like Engro Fertilizers and FFC use natural gas as a feedstock and produce ammonia, which is then converted into urea.
- 4. Contact Process:** In this process, sulphur dioxide (SO_2) gas is converted into sulphur trioxide (SO_3) gas using V_2O_5 or Pt as catalyst. Then it is transformed into oleum, and in the last is converted into sulphuric acid. This process produces highly pure and concentrated form of H_2SO_4 . Sulphuric acid is the most utilized chemical in the world, so it is often called the “King of Chemicals”. In Pakistan several plants run contact process e.g. Nimir Industrial Chemicals.
- 5. Solvay Process:** The Solvay process produces sodium carbonate (Na_2CO_3) from brine and limestone. Ammonia is added to brine, and carbon dioxide is passed through it to form sodium bicarbonate (NaHCO_3) precipitate. Heating converts it into sodium carbonate. Ammonia is regenerated using lime from calcium carbonate decomposition. The by-product formed is calcium chloride (CaCl_2). Lucky Core Industries (formerly ICI) produce soda ash for the glass, detergent and paper industries.
- 6. Chlor-Alkali Process:** The chlor-alkali process is an industrial electrolysis method that breaks down sodium chloride brine (NaCl) to produce three key chemical products like chlorine (Cl_2), sodium hydroxide (NaOH) or caustic soda, and hydrogen (H_2). It is crucial for manufacturing plastics, detergents, and water treatment products, commonly using modern



membrane cell technology for high efficiency and purity. In this regard, Sitara Chemical Industries and Ittehad Chemicals are primary players, supporting the textile and water treatment sectors.

32.13 APPLICATIONS OF INDUSTRIAL CHEMISTRY

Petrochemical Industry produces plastics, synthetic rubber, and fibres from crude oil. Crude oil is cracked (broken down) into smaller molecules. These become the building blocks for lubricants, waxes, and synthetic rubbers.

Cosmetics industry creates ingredients for makeup, soaps, and perfumes. This industry uses surfactants (for soaps), emulsifiers (to keep creams smooth), and preservatives (to prevent bacterial growth). Chemistry ensures that these products are pH-balanced for human skin.

Cement industry uses limestone and clay to make a key building material. Cement manufacturing process involves heating an intimate mixture of limestone and clay to 1500°C in a rotary kiln. The resulting product is ground with gypsum to make cement.

Food industry creates food additives, preservatives, and food processing chemicals. Sodium benzoate is mostly used as food preservatives. Hydrogenation is done to turn edible oils into solid fats like margarine. Leavening agents like sodium bicarbonate (baking soda) is used in baking. Fortification is done by adding iodine to salts or Vitamin A to oil.



Did You Know?

Why cement gets hot when you add water? Cement reacts with water in an exothermic hydration reaction, releasing heat. This is why freshly mixed cement becomes warm.



32.14 SAFETY MEASURES AND PRECAUTIONS

Industrial chemical facilities require strict safety measures to prevent accidents and protect workers and the environment. These include:

1. Workers should use personal protective equipment (PPE) such as gloves, goggles, helmets, lab coats, and protective shoes to avoid injuries from chemicals, heat, or harmful fumes.
2. Chemicals must be properly labeled, handled, and stored according to their properties. Flammable, toxic, or corrosive substances should be kept in suitable containers and separate storage areas to prevent leaks, spills, contamination, or dangerous reactions.
3. Industries should have clear emergency plans to handle fires, chemical spills, gas leaks, or explosions. Emergency exits, fire extinguishers, first-aid kits, and spill control materials should be available, and workers should know how to respond during emergencies.
4. Good ventilation systems are necessary to remove toxic gases, fumes, and dust from the workplace. Proper airflow reduces the risk of breathing harmful substances and helps maintain a safe and healthy working environment.
5. Workers must receive proper safety training on handling hazardous materials and operating equipment. Regular inspection and maintenance of machines, pipelines, and storage tanks help detect faults early and reduce the risk of industrial accidents.



**Quick Check 32.3**

- Identify two major sectors of Pakistan's economy (other than agriculture) that are heavily reliant on the chemical industry, and name one chemical product essential for each.
- Explain the physical principle of the process used to separate crude oil (in terms of intermolecular forces and boiling points) on which this separation depends.
- Many cosmetics and perfumes use esters. Name the two types of reactants needed to synthesize an ester and name the catalyst typically used.
- Explain the chemical reason why highly oxidizing chemicals (like concentrated HNO_3) must be stored separately from flammable organic chemicals (like ethanol).

Exercise



Q1. MULTIPLE CHOICE QUESTIONS

I) What does the TD_{50} value in the TI formula represent?

- Dose effective for 100 % of people.
- Lowest dose that causes harm MTC.
- Lowest dose that works MEC
- Dose causing a toxic effect in 50 % of people.

II) What is the key structural feature for penicillin's antibiotic activity?

- | | |
|----------------------------|-------------------------------------|
| a) A carboxylic acid group | b) A benzene ring |
| c) A thiazolidine ring | d) A four-membered beta-lactam ring |

III) How do opiates like morphine reduce pain?

- They destroy pain signals.
- They bind to opioid receptors, blocking pain signals.
- They come from the opium poppy.
- They build new cell walls in the brain.

IV) Which N-P-K nutrient promotes protein synthesis and chlorophyll?

- | | |
|--------------|---------------|
| a) Nitrogen | b) Phosphorus |
| c) Potassium | d) Sulphur |

V) How does acid rain primarily damage soil?

- It increases soil pH.
- It leaches essential nutrients and releases toxic Al^{3+} .
- It adds excess nitrogen.
- It directly destroys plant roots.

VI) What is a primary effect of climate change on agriculture?

- Reduced atmospheric CO_2
- Increased crop yields globally



- c) Reduced yields due to heat stress and erratic rainfall
- d) Fewer extreme weather events

VII) In Pakistan, rock salt (halite) is a key raw material for producing:

- a) Fertilizers
- b) Caustic soda and chlorine
- c) Cement
- d) Petrochemicals

VIII) Ammonia gas in industry is prepared by:

- a) Contact process
- b) Haber-Bosch process
- c) Solvay process
- d) Refining process

XI) Plastics, synthetic fibres, and synthetic rubber are primary products of the:

- a) Cement industry
- b) Petrochemical industry
- c) Cosmetics industry
- d) Food production industry

X) What is the primary purpose of ventilation systems in a chemical facility?

- a) To control storage temperature
- b) To provide clear emergency exits
- c) To assist in labeling chemicals
- d) To remove toxic fumes

Q2. SHORT ANSWER QUESTIONS

- a) Write significance of Therapeutic Window and how it differs from Therapeutic Index.
- b) How structure of penicillin allows it to inhibit the transpeptidase enzyme?
- c) What is the primary mechanism of action for opiate drugs, such as morphine, in providing analgesia (pain relief)?
- d) Why is it significantly more challenging to develop safe and effective antiviral drugs compared to antibacterial drugs (antibiotics)?
- e) What is the concept of pesticide resistance in a target pest population, linking it to the principles of natural selection and repeated application?
- f) Define soil salinization. How it can be caused by irrigation practices in regions experiencing higher temperatures and reduced precipitation.
- g) How does the chemical industry contribute to both energy production from fossil fuels and the development of renewable energy technologies?
- h) Name the industrial process used to produce caustic soda (NaOH) and chlorine (Cl₂) from the rock salt (NaCl).
- i) State two different types of products (other than fuels) that are derived from the petrochemical industry, linking them to their use in daily life.
- j) Distinguish between a corrosive hazard and a toxic hazard, giving one example of a chemical for each.

Q3. CONSTRUCTED RESPONSE QUESTIONS

- a) Drug A has an ED₅₀ of 20 mg and a TD₅₀ of 80 mg. Drug B has a Minimum Effective Concentration (MEC) of 5 mg/L and a Minimum Toxic Concentration (MTC) of 50 mg/dm³. Drug C has a therapeutic window where the effective dose is 10 mg and the toxic dose is 15 mg.



- (i) Define Therapeutic Index (TI) and calculate the TI for Drug A.
(ii) Define Therapeutic Window (TW) and identify which drug (B or C) has the wider therapeutic window. Justify your answer.
(iii) Compare the relative safety of Drug A and Drug C.
- b) (i) Contrast synthetic and organic fertilizers based on their origin.
(ii) Identify the three primary macronutrients (N, P, K) and describe the specific biological function of each in a plant.
- c) Describe the chemical pathway from Natural Gas (CH_4) to urea fertilizer. Your answer must identify the crucial intermediate compound that is synthesized from CH_4 and air.

DESCRIPTIVE QUESTIONS

- Q4. Describe the structure and mechanism of action of penicillin.
- Q5. What is Genetic Engineering? Give its main benefits and risks.
- Q6. Explain the role of industrial chemistry in economy of Pakistan. Also account the main raw materials available in Pakistan for these industries.
- Q7. Write a note on various industrial chemical processes. Also account for the applications of these chemical industries in Pakistan.
- Q8. What are important safety measures which must be followed while working in different chemical industries? Make a checklist to verify their adoption.



33

WATER

Student Learning Outcomes

[C-12-C-01 to C-12-C-08]

- Explain the chemical properties of water and how they relate to water quality and pollution.
- Identify different types of water pollution, (some examples include point source and nonpoint source pollution).
- Identify common water pollutants (some examples include oil, pesticides, and heavy metals).
- Identify and explain the sources and effects of water pollution on human health and the environment.
- Evaluate the impact of human activities on water resources, such as agriculture and industrial processes.
- Identify and explain water treatment methods and technologies, such as filtration and purification.
- Explain conservation and management strategies for protecting and preserving water resources.
- Explain the laws and regulations related to water pollution and conservation.

Water is the foundation of life. It keeps humans alive and healthy through hydration and hygiene, and removes toxic materials from the body. It allows plants to perform photosynthesis and supports agriculture by enabling crop growth. Animals rely on it to regulate body functions, and countless microorganisms depend on it for survival. Human development, agriculture, and food security all revolve around a steady supply of water. In nature, water shapes the land, maintains a balance in the climate, and recharges underground reservoirs. Ecosystems like rivers, lakes, wetlands, and oceans rely on water to support diverse plant and animal life. It is vital for energy production, transportation, urban development, and scientific research. Water scarcity threatens the environment, communities, and economies.

33.1 PROPERTIES AND QUALITY OF WATER

The chemical and physical properties of water are central to studying the nature and extent of pollution in the water bodies. The water molecule (H_2O) is a permanent dipole. This polarity renders water unique properties essential for life and the environment. Some peculiar features of water that emerge from its structure are discussed here.

i. Thermal Stability

The polarity of the water molecule results in the formation of hydrogen bonds between water molecules. Hydrogen bonding gives water a high specific heat capacity and high heat of vaporisation. This means that large bodies of water are thermally stable, resisting rapid temperature changes.



ii. Unique Solvent Abilities




Polarity also makes water a good solvent for a wide range of ionic substances, such as metallic ions, nitrates (NO_3^-) and phosphates (PO_4^{3-}), by surrounding the ions. Furthermore, the ability of water to dissolve polar organic compounds means that many pesticides and herbicides easily enter the water cycle, where they can persist and undergo bioaccumulation.

iii. Amphoteric Nature

The ability of water to act as both an acid and a base is also important for water quality. The self-ionisation of water ($K_w = 1.0 \times 10^{-14}$ at 25°C) provides the baseline for the pH scale. Most of the aquatic life is highly sensitive to pH fluctuations. For example, pollution in the form of acid rain, caused by the dissolution of sulphur dioxide (SO_2) and nitrogen oxides (NO_x), increases the concentration of hydronium ions (H_3O^+). This acidity can mobilise toxic heavy metal compounds, such as aluminium hydroxide and lead salts, from sediments into the water column by increasing their solubility through protonation or by displacing them from mineral surfaces.

iv. Oxygen in Water

The oxygen gas plays crucial role in water. It is an indicator of water quality and the level of pollution. Oxygen in water can be interpreted based on its different roles.

-  Dissolved oxygen (DO) is a key indicator of water quality and aquatic ecosystem health. It refers to the amount of oxygen available in water for aquatic organisms to breathe. High DO levels generally indicate clean, unpolluted water, while low levels may suggest pollution or excessive organic matter decomposition.
-  Biochemical Oxygen Demand (BOD) is the amount of oxygen required by microorganisms to break down organic matter in water over a specific period, usually five days at 20°C . It is a key indicator of the level of organic pollution in water. High BOD values indicate a large amount of organic matter, suggesting heavy pollution, which can deplete dissolved oxygen and harm aquatic life.
-  Chemical Oxygen Demand (COD) is the amount of oxygen required to chemically oxidise organic and inorganic substances in water, using oxidising agents (KMnO_4 , $\text{K}_2\text{Cr}_2\text{O}_7$, etc.). High COD values indicate a high concentration of oxidisable chemical pollutants, suggesting poor water quality and potential contamination from industrial or domestic waste. COD is useful for assessing the total pollution load in water.

The following table outlines the typical ranges for these parameters across different types of water sources.

Table 33.1 Typical ranges of DO, BOD, and COD in water

Water Type	DO (Dissolved Oxygen) mg/L	BOD (Biochemical Oxygen Demand) mg/L	COD (Chemical Oxygen Demand) mg/L
Very Pure Water	7 – 10	< 1	< 2



Drinking Water	> 6	< 2	< 5
Moderately Polluted	4 – 6	2 – 8	10 – 20
Treated Sewage	2 – 4	10 – 30	30 – 100
Raw Sewage	< 1	100 – 400	200 – 1000
Industrial Waste	0 – 2	500 – 5000+	1000 – 20,000+

v. Redox Potential

The redox potential of water is a measure of the oxidising and reducing nature of a water body. In well-oxygenated water, chemical species exist in their most oxidised forms, such as SO_4^{2-} and CO_2 . However, in polluted or stagnant water, where oxygen is depleted, the environment becomes reducing. This leads to the formation of toxic substances like hydrogen sulphide (H_2S) and ammonia (NH_3). Understanding these chemical equilibria and the molecular behaviour of H_2O allows us to predict how specific contaminants will migrate, transform, and ultimately impact the global water supply.



Quick Check 33.1



- Explain how the polarity of water facilitates the transport of agricultural pollutants like pesticides into the water cycle.
- Differentiate between Biological Oxygen Demand (BOD) and Chemical Oxygen Demand (COD) as indicators of water quality.

33.2 SOURCES OF WATER POLLUTION

The sources of pollution may either be small scale and single point or a variety of locations or points adding the same or various types of pollutions. Based on this, the sources of water pollution are divided into two types.

1. Point Source Pollution

Point-source pollution is the contamination that enters a water body from a single, discrete, and identifiable location or point. Because the discharge is concentrated at one point, it often causes a pollution plume. Immediately downstream or at the site of discharge, concentrations of the pollutant (such as heavy metals or organic waste) are at their highest, leading to localized acute toxicity. An example is a factory discharging lead or mercury salts directly into a river via a specific wastewater pipe. Another example is a storage tank at a chemical plant leaking its contents into the soil and subsequently into the groundwater.



Figure 33.1 Urban Sewage polluting water channels (point source pollution)



2. Non-Point Source (NPS) Pollution

Non-point source pollution, also known as diffused pollution, occurs when rainfall or snowmelt moves over and through the ground. As the water moves, it picks up and carries away natural and human-made pollutants, finally depositing them into lakes, rivers, wetlands, and coastal waters. Unlike point sources, NPS pollution is heavily dependent on weather events like heavy storms. It results in a mixture of various pollutants at lower concentrations across a much wider area. Some examples of non-point pollution sources are:

- 🌿 Rain washing excess ammonium nitrate (NH_4NO_3), fertilizers, and pesticides from thousands of hectares of farmland into a river system.
- 🌿 Stormwater moving over impermeable surfaces (roads and car parks), collecting leaked engine oils (hydrocarbons), zinc from tires, and road salts.



Quick Check 33.2



- a) Classify these as point or non-point sources of water pollution, explain your choice.
 - i) The outfall pipes used to release treated sewage into a bay or river from wastewater treatment plants.
 - ii) The "acid rain" caused by the nitrogen oxides (NO_x) from distant traffic or power stations dissolved in rainwater.
- b) Give two major differences between point and non-point pollution sources.

33.3 COMMON WATER POLLUTANTS

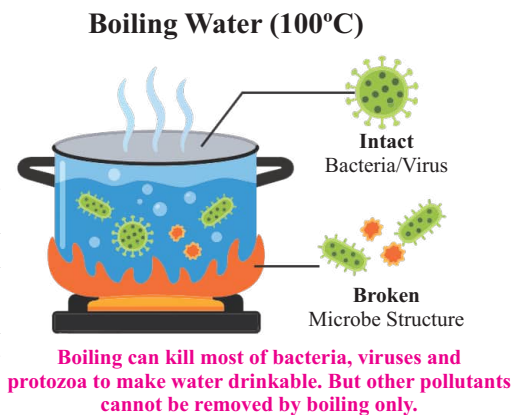
1. Microbiological Pollutants

Microbiological pollution is the contamination of water by harmful microorganisms, such as bacteria, viruses, protozoa, and parasites which can pose serious health risks to humans and animals. This type of pollution typically results from the discharge of untreated or inadequately treated sewage, animal waste, hospital waste, and runoff from agricultural lands into water bodies. Common pathogens found in microbiologically polluted water include Escherichia coli, Salmonella, and Giardia. Microorganisms in water, such as bacteria, viruses, and protozoa are the major cause of water-borne diseases. Common water-borne diseases include cholera, typhoid, dysentery, and hepatitis A.

2. Chemical Pollutants (Heavy Metals and Pesticides)

a) Heavy Metals

This type of pollution often includes toxic heavy metals like mercury, lead, arsenic, and cadmium and agricultural chemicals such as pesticides and herbicides. Heavy metals can enter water systems through industrial discharge, mining operations, and improper waste disposal. Sources of some heavy metals are given below.



- Mercury can enter water primarily from coal combustion, gold mining, and industrial waste from thermometer or battery manufacturing. In aquatic sediments, bacteria convert inorganic mercury into methylmercury ($[\text{CH}_3\text{Hg}]^+$), which is more dangerous.
- The major sources of lead are leaded petrol (which is now banned worldwide); old plumbing (lead pipes), lead-acid batteries, and paints. Lead ions (Pb^{2+}) often enter water systems through the corrosion of pipes.
- Metal plating, plastic stabilisers, and phosphate fertilizer impurities are major sources of cadmium in water. These chemicals are usually non-biodegradable in nature and can accumulate in the food chain, posing long-term risks to aquatic life and humans, equally.

Health effects of Heavy Metals

Heavy metals have high atomic weights and densities. Due to their non-biodegradable nature, they tend to accumulate in the tissues of living organisms, and are particularly dangerous. Some common heavy metals and their hazards are given in the following lines.

- Methyl mercury ($[\text{CH}_3\text{Hg}]^+$) is highly fat-soluble, allowing it to easily cross biological membranes and undergo **biomagnification**. It is a potent neurotoxin that crosses the blood-brain barrier. Long term exposure leads to Minamata disease, characterized by ataxia, numbness in the hands and feet, and general muscle weakness.
- Lead interferes with the production of haemoglobin, leading to anaemia. In children, it acts as a cumulative poison that causes irreversible neurological damage and developmental delays.
- Long-term ingestion of cadmium (Cd) leads to "Itai-itai" disease, where cadmium replaces calcium in the bones, making them extremely brittle. It also causes severe kidney damage (nephrotoxicity).

The limiting concentrations (mg/L) of some heavy metals are provided in **Table 33.2**.



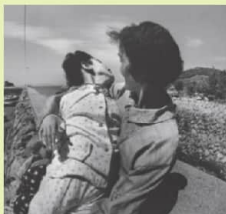
Cd^{2+} ions have higher charge density so they can replace Ca^{2+} ions in bones

Table 33.2 WHO permissible limits of heavy metals in drinking water

Heavy Metal	WHO Limit (mg/L)
Arsenic (As)	0.01
Chromium (Cr)	0.05
Copper (Cu)	2.0
Lead (Pb)	0.01
Cadmium (Cd)	0.003
Mercury (Hg)	0.006

Did You Know?

The Minamata Disaster was a severe case of industrial pollution that occurred in the 1950s in Minamata, Japan. Caused by the release of methylmercury into the water, it led to widespread mercury poisoning, affecting thousands of people with neurological damage and causing birth defects, deaths, and environmental devastation. At right is the picture of a patient afflicted by such a neurological disease.



a) Pesticides and Herbicides

Pesticides and Herbicides such as DDT and Glyphosate are another hazardous material that pollute water and cause severe human health issues. The major sources of these are agricultural runoff and domestic gardening. They are non-polar and insoluble in water but highly soluble in the fatty tissues of fish and birds. Many older pesticides like DDT are persistent organic pollutants (POPs). Pesticides are linked to hormonal disruption and developmental problems. Chemical pollution also degrades water quality, reduces biodiversity, and disrupts aquatic ecosystems.

Health Effects

Many pesticides act as endocrine disruptors like natural hormones, e.g., estrogen. This can lead to the reproductive failure in wildlife (e.g., thinning of eggshells in birds) and is linked to hormonal cancers in humans. Polychlorinated biphenols (PCBs) have been used in electrical transformers as coolants; they leak into water from hazardous waste sites. PCBs are classified as probable human carcinogens. They also suppress the immune system and cause skin conditions, such as chloracne.

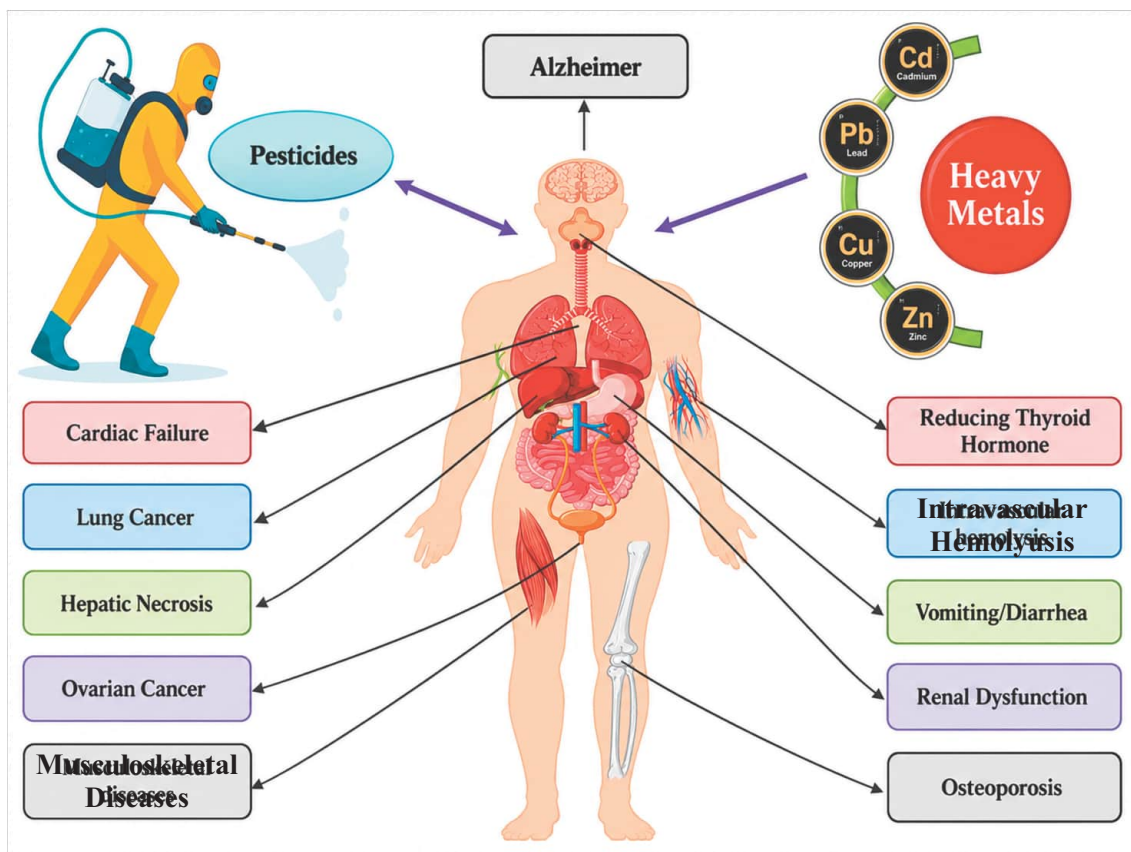


Figure 33.2 Effects of heavy metals and pesticides on the human body



3. Eutrophication

Nutrient pollution, also known as **eutrophication**, occurs when excessive amounts of nutrients, primarily nitrogen and phosphorus, enter into water bodies, usually from agricultural runoff, wastewater discharge, and stormwater. Although these nutrients are essential for plant growth, their excess in aquatic environments leads to the rapid growth of algae, commonly referred to as algal blooms. These blooms can block sunlight from reaching underwater plants. When they die and decompose, they consume large amounts of oxygen, creating hypoxic or “dead zones” where aquatic life cannot survive. Eutrophication severely disrupts aquatic ecosystems, reduces biodiversity, harms fisheries, and affects water quality for recreational and drinking purposes. High nitrate levels in drinking water are particularly dangerous for infants. It can lead to "Blue Baby Syndrome" (Methaemoglobinaemia), where nitrates reduce the blood's capacity to carry oxygen.

4. Oil

Oil pollution in oceans, particularly from oil leaks and spills caused by ships, is a major environmental threat. When oil is accidentally released into the sea, it spreads rapidly across the water surface, forming a layer that blocks sunlight and reduces oxygen exchange. This severely harms marine life, including fish, birds, and mammals. Marine mammals can ingest the toxic oil while grooming, and fish may suffer from long-term health issues due to exposure to hydrocarbons. Oil pollution also damages coastal habitats such as mangroves, coral reefs, and beaches.



(a)



(b)

Figure 33.3 (a) Eutrophication in water bodies damages aquatic life, (b) Marine life suffers from oil pollution

5. Plastic and Solid Waste

Plastic and solid waste pollution in oceans and other water bodies is a growing environmental crisis. Millions of tons of plastic waste including bottles, bags, fishing nets, and microplastics are dumped into rivers, lakes, and oceans every year. Unlike organic materials, plastics do not biodegrade; instead, they break down into smaller particles that persist in the environment for centuries.

Marine animals often mistake plastic for food, leading to ingestion, choking, or internal injury, which can be fatal. Sometimes entanglement in old fishing gear and other debris in the sea bed also causes injury or death to countless sea creatures, including turtles, dolphins, and birds.



Furthermore, microplastics have entered the food chain, raising concerns about their impact on human health. Solid waste pollution also clogs waterways, disrupts aquatic habitats, and reduces water quality.

**Quick Check 33.3**

- i. Name the sources of heavy metals.
- ii. How oil spill is hazardous to the marine life?
- iii. Pesticides like DDT are "non-polar and insoluble in water" yet they "pollute water and cause severe human health issues. Explain.

33.4 WATER POLLUTION DUE TO HUMAN ACTIVITIES

Human activities are a major cause of water pollution across the globe. As populations grow and industries expand, more waste and pollutants are introduced into water bodies. Improper waste management and lack of environmental regulations often lead to contaminants reaching rivers, lakes, and oceans.

1. Industrial Activities

Industrial activities are the major source of water pollution. Factories often discharge harmful chemicals, heavy metals, and toxic waste directly into rivers, lakes, and oceans. The common industries that release pollution, are oil refineries, chemical plants, automobile industry, fertilizers, tanneries, etc.

2. Agricultural Activities

Agricultural activities contribute significantly to water pollution through the runoff of fertilizers, pesticides, and herbicides into nearby water bodies. Poor irrigation practices can increase soil erosion, washing sediments into rivers and streams. In many areas, drainage from farmlands carries pollutants that contaminate both surface and groundwater sources.

3. Domestic and Municipal Waste

Domestic and municipal waste is one of the major sources of water pollution. In many areas, untreated or poorly treated sewage and solid waste from cities is discharged directly into rivers, lakes, or oceans, introducing harmful bacteria and viruses. Household waste such as detergents, oils, and chemicals often enter drains and eventually reach water bodies. Especially, plastics are frequently dumped in or near water channels, leading to blockages and long-term pollution.

4. Deforestation and Land Use for Urban Development

Deforestation and land use significantly contribute to the water pollution. When trees and vegetation are removed, the soil becomes loose and more prone to erosion, leading to increased sediment in rivers and streams. This sediment can clog waterways, harm aquatic habitats, and reduce water quality. Urban development and construction activities often introduce pollutants and debris into runoff water.

5. Recreational Activities

Recreational activities such as boating, swimming, and camping can contribute to water pollution



if not properly managed. Boats often release oil, fuel, and other chemicals into the water, harming aquatic life. Littering by visitors, including plastics, food wrappers, and other waste, can pollute lakes and rivers.

6. Marine Transport

Marine transport activities contribute to water pollution through the discharge of oil, fuel, and other chemicals from ships and boats. Accidental oil spills, wastewater and sewage from vessels, and ships are major causes of pollution. Routine maintenance, such as hull cleaning and painting, can also release toxic substances into the water. These practices collectively harm aquatic life and reduce water quality.



Quick Check 33.4



- a) A river passes by three regions in a country: a rural area with vast agricultural land and a lot of cattle; an industrial area with many paint and battery industries; and a large residential area of a big city:
- Predict which type of pollutants will be added to the river in the rural area; organic, inorganic, or both? Name two of them.
 - Which metals are most likely to pollute the water near the industrial area?
 - Name the regions that will contaminate the water with chemicals that lead to Eutrophication.
 - Name four contaminants that will pollute the water near the residential area.

33.5 EFFECT OF WATER POLLUTION ON THE ENVIRONMENT

Pollutants can alter the physical and chemical properties of water, making it difficult for plants and animals to survive. Common environmental impacts include **loss of biodiversity, habitat destruction, disruption of food chains, and decline in water quality.**

1. Destruction of Eco Systems and Biodiversity

Water pollution, such as oil, heavy metals, and pesticides severely damages ecosystems and aquatic life by introducing harmful chemicals, plastics, and waste into rivers, lakes, and oceans. Polluted water reduces oxygen levels, causing hypoxia and making it difficult for aquatic life to survive. It damages coral reefs and disrupts food chains. Toxic chemicals, sewage, and industrial waste can kill or harm aquatic organisms, reducing the variety of life in rivers, lakes, and oceans. Polluted water disrupts breeding cycles, food sources, and migration patterns, leading to population decline and even extinction of sensitive species. It also affects birds and animals that rely on water bodies for survival.

2. Nutrient Overload (Eutrophication)

Nutrient overload from water pollution, especially excess nitrogen and phosphorus from fertilizers and sewage, leads to a rapid growth of algae, which block sunlight and reduce oxygen levels in the water. Eutrophication disrupts ecosystems, kills fish and other marine species, and damages water quality.



3. Bioaccumulation and Magnification

Bioaccumulation and biomagnification are serious adverse effects of water pollution, where toxic substances like mercury, lead, and pesticides build up in organisms over time. These toxins accumulate in the bodies of aquatic animals and become more concentrated as they move up the food chain. Top predators, including humans, often receive the highest doses.

4. Soil Degradation and Plant Life Damage

Water pollution significantly contributes to soil degradation and damages plant life. Contaminants like heavy metals, industrial waste, and excessive nutrients seep into the soil, altering its structure and fertility. Accumulated chemicals disrupt the soil's natural microbial activity, essential for plant health. Plants exposed to polluted water may exhibit stunted growth, leaf discoloration, and even die.

5. Methane Emission by Decaying Organic Matter

When sewage, agricultural runoff, or industrial waste enters water bodies, it boosts the growth of algae and other organisms. As these organisms die and decompose in oxygen-poor (anaerobic) conditions, methane, a potent greenhouse gas, is released. The excess methane contributes to climate change and worsens global warming.



Quick Check 33.5



- a) Methylmercury ($[\text{CH}_3\text{Hg}]^+$) is "highly fat-soluble," allowing it to cross biological membranes and the blood-brain barrier.
- i. Contrast the chemical structure of the methylmercury cation ($[\text{CH}_3\text{Hg}]^+$) with the inorganic mercury ion (Hg^{2+}). Explain why the presence of the methyl group ($-\text{CH}_3$) alters its solubility in lipid bilayers of living cells compared to the inorganic ion.
- ii. Predict the impact on the "biomagnification" process if ($[\text{CH}_3\text{Hg}]^+$) was highly water-soluble but had low fat solubility.
- b) How the water pollution can contribute to the global warming?

33.6 WASTEWATER TREATMENT

Depending on the type and severity of pollution, such as organic matter, chemicals, or pathogens, different water treatment methods are used. These techniques are used at different levels of water treatment, i.e., primary treatment (removal of physical debris), secondary treatment (biological processing), and tertiary treatment (chemical purification). In the following steps different technologies (physical, biological, and chemical) suitable to remove various contaminants in water are being provided

I. Screening and Sedimentation

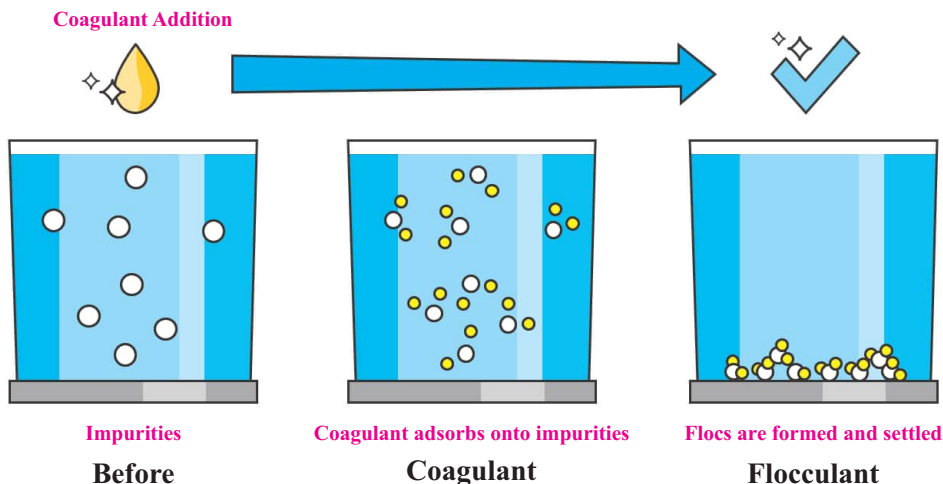
The initial stage of water treatment typically involves screening and sedimentation. Large insoluble particles are removed by passing water through metal screens. This is followed by sedimentation, where water is held in large tanks to allow suspended solids to settle at the bottom under the influence of gravity.

ii. Coagulation and Flocculation

To speed up the settling of finer colloidal particles, coagulation and flocculation are employed. This process is done if required. It involves the precipitation of dissolved contaminants (e.g.,



heavy metals, phosphates) into insoluble forms for removal. Chemical coagulants, such as aluminium sulphate ($\text{Al}_2(\text{SO}_4)_3$), are added to the water. These chemicals cause the smaller particles to clump together into larger masses called "floc", which are then easily removed.



iii. Filtration

Once the bulk of the solids has been removed, the water undergoes filtration. This is a mechanical process designed to remove the remaining fine suspended matter and some microorganisms. In a standard treatment plant, water passes through layers of graded sand and gravel. The sand acts as a physical barrier, trapping particles within the pores between grains. For more advanced purification, activated carbon is used.

iv. Disinfection

Filtration alone cannot remove dissolved ions or microscopic pathogens; therefore, chemical purification is necessary. Chlorination is the most common method of disinfection. The other methods include sodium hypochlorite (NaOCl); ozone (O_3) or sometimes with hydrogen peroxide (H_2O_2). When chlorine gas or sodium hypochlorite is added to water, it forms hypochlorous acid (HOCl), which penetrates the cell walls of bacteria and viruses, disrupting their cell functions.

iv. Reverse Osmosis (RO) and Ion Exchange Methods

For the production of high-purity water, such as that required in laboratory settings or regions with high salinity, reverse osmosis (RO) and ion exchange method are utilized.

The RO method uses a semi-permeable membrane, which filters out dissolved salts, bacteria, and other impurities under pressure. Ion exchange is an important technology for "softening" water. Hard water contains high concentrations of Ca^{2+} and Mg^{2+} ions, which interfere with industrial processes and soap efficiency. In an ion-exchange column, these ions are swapped for Na^+ or H^+ ions.



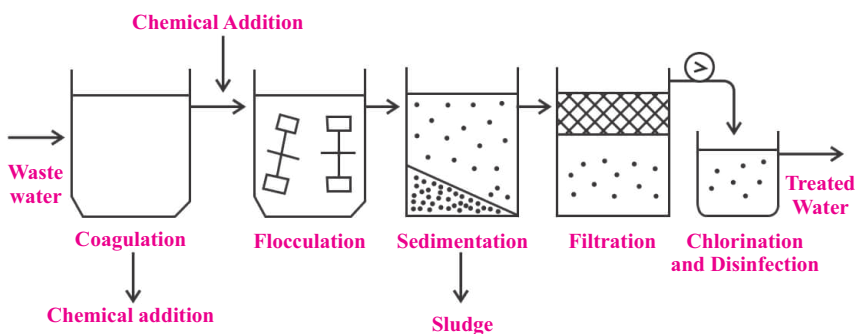


Figure 33.4 A sketch of water treatment plant

33.7 PROTECTION AND CONSERVATION OF WATER RESOURCES

33.7.1 Pollution Control

It can be done by the following strategies.

- 1. Imposing strict discharge standards for industries and municipalities to prevent harmful pollutants from entering water bodies.
- 2. By upgrading and expanding sewage treatment plants (STPs), installing Effluent Treatment Plants (ETPs), and adopting modern technologies, such as membrane filtration and bioreactors.
- 3. By continuous water quality monitoring, which enables the detection of pollutants, ensuring timely responses to contamination events.
- 4. By implementing strict penalties for polluters and offering incentives for clean practices. This approach discourages environmental violations while encouraging industries and communities to adopt sustainable, pollution-free operations.

33.7.2 Efficient Use of Water

Conservation of water is of utmost importance in the current era due to water shortage faced by a large pollution fraction of the world. Following strategies help conserve water.

- 1. Water-saving technologies in agriculture such as, drip irrigation and sprinkler irrigation in agriculture significantly reduced water wastage while improving crop yield and efficiency.
- 2. Reusing and recycling greywater, such as household laundry, dishwashing, and bathing water for landscaping, toilet flushing, and industrial cooling helps conserve freshwater resources and reduces the burden on sewage treatment systems.
- 3. Implementing rainwater harvesting systems in both urban and rural areas is a sustainable method to capture and store valuable water resources.
- 4. Regular repair and maintenance of water supply infrastructure minimize leaks and water loss, ensuring efficient delivery and reduced resource wastage.



- Constructing small dams and recharge wells helps store rainwater and replenish groundwater levels, providing a reliable source of water during dry periods.
- Community engagement and awareness through public education campaigns on water-saving behaviours and involvement of local communities in water body protection.

33.8 RULES AND REGULATIONS REGARDING WASTE POLLUTION AND CONSERVATION

The Government of Punjab has made several acts and laws to address the water pollution within its jurisdiction. The Punjab Environmental Protection Agency (EPA) Punjab regularly issues relevant rules and regulations for all concerned stakeholders. Below is a comprehensive overview of the key self-explanatory rules and regulations issued by EPA Punjab (Pakistan) related to water pollution control and conservation.

Table 33.3 Key environmental regulations and conservation measures

Act / Regulation	Primary Scope and Powers	Penalties for Non-Compliance
Punjab Environmental Protection Act, 1997	Pollution prevention.	Fines up to Rs 5 million, plus additional daily fines of up to Rs 100,000.
Punjab Water Act, 2019	Prohibits discharging pollutants or blocking flow.	Up to 3 months imprisonment and/or a Rs 500,000 fine.
Punjab Irrigation, Drainage and Rivers Act, 2023	Sets water usage and drainage fees, regulates discharge permits to prevent industrial/agricultural pollution.	—————
Punjab Water and Sanitation Authority Act, 2025	Establishes the Authority in major cities (Lahore, Multan, etc.) for integrated resource management and groundwater conservation.	—————



Did You Know?

The penalty for the use of hosepipes for car-washing and flood irrigation in domestic lawns or gardens is a Fine of Rs 10,000 under the Pakistan Penal Code.



Exercise

Q1. MULTIPLE CHOICE QUESTIONS:

1. Four choices are given for each questions. Select the correct choice.

I. Which property of water is primarily responsible for its ability to resist rapid temperature changes in large aquatic ecosystems?

- a) Amphoteric nature
- b) High specific heat capacity
- c) The permanent dipole
- d) High redox potential

II. A water sample is found to have a very high Biochemical Oxygen Demand (BOD). What does this most likely indicate about the water body?

- a) Highly oxygenated and healthy
- b) High concentration of nitrates and phosphates.
- c) High organic pollution
- d) A high pH

III. Which of the following best describes the formation of a "pollution plume"?

- a) Agricultural runoff
- b) Discharge of heavy metal salts
- c) The mixture of hydrocarbons and road salts
- d) Snowmelt through uncontaminated forest soil.

IV. Why is Non-Point Source (NPS) pollution considered "weather-dependent" compared to Point Source pollution?

- a) NPS pollutants are only toxic when the temperature of the water rises.
- b) NPS pollution requires precipitation to wash diffuse surface contaminants into water bodies.
- c) Point sources only discharge waste during specific industrial seasons.
- d) Rainfall neutralizes the localized acute toxicity of point source plumes.

V. Bacteria in aquatic sediments convert inorganic mercury into methylmercury ($[\text{CH}_3\text{Hg}]^+$). Which statement best explains why this conversion increases the ecological hazard?

- a) Methylmercury dissolves more readily in the water
- b) Methyl mercury is biodegradable and enters nutrient cycle.
- c) Methylmercury is highly fat-soluble
- d) Methylmercury is a solid that clogs the gills of fish.

VI. Which condition is a direct result of Cadmium (Cd) replacing Calcium (Ca) in the skeletal system?

- a) Minamata disease
- b) Blue Baby Syndrome
- c) Itai-itai disease
- d) Chloracne

VII. What is the primary chemical role of Aluminium Sulphate ($\text{Al}_2(\text{SO}_4)_3$) in the wastewater treatment process?

- a) To kill pathogenic bacteria.



- b) To act as a semi-permeable membrane.
- c) Converting colloidal particles to floc.
- d) To adsorb organic contaminants.

VIII. Ion exchange technology "softens" water by replacing calcium (Ca^{2+}) and magnesium (Mg^{2+}) ions with:

- a) Chlorine (Cl_2) or ozone (O_3)
- b) Sodium (Na^+) or hydrogen (H^+) ions
- c) Aluminum (Al^{3+}) or iron (Fe^{3+}) ions
- d) Carbonate (CO_3^{2-}) or phosphate (PO_4^{3-}) ions

Q2. SHORT-ANSWER QUESTIONS:

- a) Differentiate between Point Source and Non-Point Source pollution in terms of the "concentration" of pollutants at the site of entry.
- b) Using an example from the text, explain how an underground storage tank can become a point source of pollution.
- c) Identify two types of chemical pollutants commonly found in urban storm water runoff.
- d) Differentiate between the "solubility" of pesticides like DDT and inorganic nutrients like nitrates in the context of the water cycle.
- e) Explain why microplastics are considered a "growing environmental crisis" differently than organic solid waste.
- f) How an oil spill physically disrupts the chemical balance of a marine ecosystem?
- g) Why are synthetic organic pollutants, like PCBs and pesticides, considered "persistent" in the environment?
- h) How do the decomposition of organic matter in polluted water contributes to global warming?
- i) Name four methods used for water conservation.
- j) What is the role of "industrial discharge" in water pollution?
- k) Both reverse osmosis (RO) and ion exchange methods are used to obtain high-purity water?
 - a) Differentiate between the processes involved in both these methods.
 - b) What impurities do these methods target?

Q3. CONSTRUCTED RESPONSE QUESTIONS

- a) Explain the relationship between acid rain and the presence of toxic heavy metals in aquatic environments.
- b) Analyze the environmental impact of agricultural runoff as a Non-Point Source of pollution. Reference specific chemicals in your answer.
- c) Evaluate the role of agricultural runoff" in contributing to different types of water pollution.
- d) Evaluate the benefits and the long-term chemical risks involved in the use of chlorine as a disinfectant.

DESCRIPTIVE QUESTIONS:

- Q4. Describe the effects of heavy metals and pesticides on the human body.
- Q5. Explain the different sources of heavy metals and organic compounds.
- Q6. Describe various technologies used in water treatment.
- Q7. Explain the difference between DO, BOD, and COD; How they relate to the water pollution?



Instructions for Preparation of Exam Paper of Chemistry for Class 12

ESSENTIAL INSTRUCTIONS FOR PAPER SETTERS

The paper of Chemistry for class 12 will consist of eighty-five (85) marks. Timing of the paper will be three (03) hours. The paper will be made as per following details:

Part-I: Objective:	Q-1: One multiple-choice question (MCQ) from each chapter.	$1 \times 17 = 17$																														
Part-II: Subjective:	Q-2: 8 short answer questions have to be answered out of 12. The detail is as follows: <table border="1" data-bbox="329 550 1014 631"> <tbody> <tr> <td>Chapter</td> <td>17</td> <td>18</td> <td>19</td> <td>20</td> <td>24</td> <td>25</td> </tr> <tr> <td>No. of Short Questions</td> <td>1</td> <td>1</td> <td>3</td> <td>2</td> <td>3</td> <td>2</td> </tr> </tbody> </table>	Chapter	17	18	19	20	24	25	No. of Short Questions	1	1	3	2	3	2	$2 \times 8 = 16$																
	Chapter	17	18	19	20	24	25																									
	No. of Short Questions	1	1	3	2	3	2																									
	Q-3: 8 short answer questions have to be answered out of 12. The detail is as follows: <table border="1" data-bbox="329 744 1014 825"> <tbody> <tr> <td>Chapter</td> <td>21</td> <td>22</td> <td>23</td> <td>27</td> <td>28</td> <td>29</td> </tr> <tr> <td>No. of Short Questions</td> <td>1</td> <td>1</td> <td>2</td> <td>2</td> <td>3</td> <td>3</td> </tr> </tbody> </table>	Chapter	21	22	23	27	28	29	No. of Short Questions	1	1	2	2	3	3	$2 \times 8 = 16$																
Chapter	21	22	23	27	28	29																										
No. of Short Questions	1	1	2	2	3	3																										
Q-4: 6 short answer questions have to be answered out of 9. The detail is as follows: <table border="1" data-bbox="329 938 940 1019"> <tbody> <tr> <td>Chapter</td> <td>26</td> <td>30</td> <td>31</td> <td>32</td> <td>33</td> </tr> <tr> <td>No. of Short Questions</td> <td>1</td> <td>2</td> <td>2</td> <td>2</td> <td>2</td> </tr> </tbody> </table>	Chapter	26	30	31	32	33	No. of Short Questions	1	2	2	2	2	$2 \times 6 = 12$																			
Chapter	26	30	31	32	33																											
No. of Short Questions	1	2	2	2	2																											
Part-III: Subjective:	<p>This section will contain five detailed questions bifurcated in two-part a & b (carrying 4 & 4 marks each) and students have to attempt 3 questions The detail is as follows:</p> <table border="1" data-bbox="329 1195 618 1301"> <caption>Question No 5:</caption> <tbody> <tr> <td>Chapter</td> <td>17</td> <td>21</td> </tr> <tr> <td>Part</td> <td>a</td> <td>b</td> </tr> </tbody> </table> <table border="1" data-bbox="329 1349 618 1428"> <caption>Question No 6:</caption> <tbody> <tr> <td>Chapter</td> <td>18</td> <td>26</td> </tr> <tr> <td>Part</td> <td>a</td> <td>b</td> </tr> </tbody> </table> <table border="1" data-bbox="329 1478 618 1557"> <caption>Question No 7:</caption> <tbody> <tr> <td>Chapter</td> <td>20</td> <td>31</td> </tr> <tr> <td>Part</td> <td>a</td> <td>b</td> </tr> </tbody> </table> <table border="1" data-bbox="725 1195 1014 1301"> <caption>Question No 8:</caption> <tbody> <tr> <td>Chapter</td> <td>22</td> <td>32</td> </tr> <tr> <td>Part</td> <td>a</td> <td>b</td> </tr> </tbody> </table> <table border="1" data-bbox="725 1349 1014 1428"> <caption>Question No 9:</caption> <tbody> <tr> <td>Chapter</td> <td>23</td> <td>33</td> </tr> <tr> <td>Part</td> <td>a</td> <td>b</td> </tr> </tbody> </table>	Chapter	17	21	Part	a	b	Chapter	18	26	Part	a	b	Chapter	20	31	Part	a	b	Chapter	22	32	Part	a	b	Chapter	23	33	Part	a	b	$3 \times 8 = 24$
Chapter	17	21																														
Part	a	b																														
Chapter	18	26																														
Part	a	b																														
Chapter	20	31																														
Part	a	b																														
Chapter	22	32																														
Part	a	b																														
Chapter	23	33																														
Part	a	b																														



xiii) The types of transitions possible in UV-visible region for a compound with molecular formula C_2H_4 are:

- a) $n \rightarrow \pi^*$ b) $n \rightarrow \sigma^*$ c) $\sigma \rightarrow \sigma^*$ d) $\pi \rightarrow \pi^*$

xiv) NMR relies on the magnetic properties of nuclei known as:

- a) Chemical shift b) Nuclear density c) Nuclear spin d) Signal intensity

xv) Which property makes ceramics suitable for furnace bricks?

- a) Conductivity b) Low density c) High melting point d) Flexibility

xvi) Which N-P-K nutrient promotes protein synthesis and chlorophyll?

- a) Nitrogen b) Phosphorus c) Potassium d) Sulphur

xvii) Which condition is a direct result of Cadmium (Cd) replacing Calcium (Ca) in the skeletal system?

- a) Minamata disease b) Blue Baby Syndrome c) Itai-itai disease d) Chloracne

Subjective Type (Part I)

Time allowed: 2.40 Hrs.

Max. Marks: 68

Q. 2: Write short answers to any eight (08) questions: (16)

- i. Give the products of the thermal decomposition of barium nitrate. (17)
- ii. Define a bidentate ligand and state how many bonds it forms to the central ion. (18)
- iii. Give the names and examples of two functional groups containing oxygen.
- iv. Define catenation. Give its importance.
- v. Alkanes have no functional group. Justify.
- vi. Differentiate between the chocolate and coffee by drawing their structures.
- vii. Describe, with the help of a diagram, the bonding in benzene.
- viii. Explain why electrophiles, such as bromine, react much more readily with phenol than with benzene.
- ix. What is the chromophore in azo dyes? What are its functions in dyes?
- x. Why amides are less basic than ammonia?
- xi. Differentiate between synthesis and retrosynthesis.
- xii. How a carboxylic group is converted to an amide group?

Q. 3: Write short answers to any eight (08) questions: (16)

- i. Which among haloalkanes or haloarenes, is more reactive towards electrophiles?
- ii. Which alcohol can't change color of acidified potassium dichromate?
- iii. Explain why carboxylic acid is more acidic than ethanol.
- iv. Give reaction of methanal with the Tollen's reagent.
- v. What is the role of iron in the body?
- vi. How enzyme inhibitors are important in our body and medicine?
- vii. Why is TLC not suitable for large-scale separation?



- viii. What is the function of injector port in GC?
- ix. Differentiate between partition and adsorption chromatography.
- x. Write the ranges of electromagnetic spectrum.
- xi. How the chemical composition of a substance can be investigated by using spectroscopy?
- xii. Predict two fragment ions that you would expect to see in the mass spectrum of butan-1-ol and state the m/e value of each ion.

Q. 4: Write short answers to any six (06) questions: (12)

- i. Name two different polymers used in artificial organs and state the specific application for each.
- ii. What does the number of peaks in a ^{13}C NMR spectrum represent?
- iii. Why do O-H and N-H peaks disappear after a D_2O shake?
- iv. Define energy density and give one example.
- v. Name two specific semiconductors mentioned in the text and their modern applications.
- vi. How structure of penicillin allows it to inhibit the transpeptidase enzyme?
- vii. What is the concept of pesticide resistance in a target pest population, linking it to the principles of natural selection and repeated application?
- viii. Name four methods used for water conservation.
- ix. What is the role of "industrial discharge" in water pollution?

Subjective Type (Part II)

Note: Attempt any three questions.

Q.5:

- (a) Explain the solubility of sulphates and hydroxides of Group 2 elements, and discuss the trend in their solubility down the group with appropriate examples. (4)
- (b) Describe the $\text{S}_{\text{N}}1$ and $\text{S}_{\text{N}}2$ mechanisms of nucleophilic substitution in halogenoalkanes. (4)

Q.6:

- (a) Discuss the redox reaction of transition metals giving one example in detail. (4)
- (b) Define the condensation polymer. Discuss the formation of polyester. (4)

Q.7:

- (a) In contrast to benzene, the reaction of an alkene with bromine does not need a halogen carrier. Compare the different reactivities of benzene and alkenes towards chlorine. (4)
- (b) Explain how X-rays interact with crystals to produce diffraction patterns and how these patterns help determine atomic positions. (4)

Q.8:

- (a) Write any two reactions of phenol involving substitution on the benzene ring. (4)
- (b) What are important safety measures which must be followed while working in different chemical industries? Make a checklist to verify their adoption. (4)

Q.9:

- (a) Prepare carboxylic acid starting from ester, alcohol, alkane nitril and methyl benzene. (4)
- (b) Evaluate the benefits and the long-term chemical risks involved in the use of chlorine as a disinfectant. (4)



