

# CHEMISTRY

# 12



**PUNJAB CURRICULUM AND  
TEXTBOOK BOARD, LAHORE**

All rights are reserved with the **Punjab Curriculum and Textbook Board, Lahore.**

No part of this book can be copied, translated, reproduced or used for preparation of test papers, guide books, key notes and helping books etc.

## AUTHORS:

- Dr. Jameel Anwar
- Dr. Shaukat Ali
- Dr. M. Akram Kashmiri
- Mrs. Nasreen Batool Qasier
- Mrs. Nazeer Ahmad Chaughtai (L)
- Mr. Saad Ali Khan
- Mr. Naseem Asghar Ginai
- Mr. Iftikhar Ahmad
- Dr. Imtiaz Ahmad
- Syed Ghulam Akbar
- Ch. Karam Elahi (L)
- Mr. Tariq Ahmad Niazi
- Mr. Zafar Mehdi Zafar
- Mr. Javed Iqbal Lodhi
- Mr. Muhammad Shoaib Jehangir

## EDITORS:

- **Prof. Dr. Jameel Anwar**  
Ex-Director, Institute of Chemistry  
Punjab University, Lahore.
- **Prof. Dr. Abid Zia**  
Vice Principal (Rtd.),  
Government College of Science, Lahore.
- **Prof. Dr. M. Akram Kashmiri**  
Ex-Chairman, Chemistry Department,  
Government College University, Lahore.

## COMPOSING, DESIGNING AND ILLUSTRATIONS:

- Hafiz Inam-ul-Haq
- Izhar Sons Printers,  
9 Rattigan Road, Lahore
- Qadri Graphics, Lahore

## ARTIST:

- Aisha Waheed

## SUPERVISION:

- **Dr. Saman Jamil**  
Senior Subject Specialist Chemistry
- **Mr. Atta Dastgeer**  
Subject Specialist Chemistry  
Ex-Director Manuscripts,  
PCTB, Lahore

## Director (Manuscripts):

- Ms. Nisar Qamar

Published by : Zia ul Quran Publications Lahore.

Printed by : Ahmad Tayyeb Printer Lahore.

Date of Printing	Edition	Impression	Copies	Price
July 2019	1st	5	15600	154.00

# CONTENTS

Chapter	Subject	Page
1.	Periodic Classification of Elements and Periodicity	1
2.	s-Block Elements	20
3.	Group IIIA and Group IVA Elements	37
4.	Group VA and VIA Elements	56
5.	The Halogens and the Noble Gases	79
6.	Transition Elements	97
7.	Fundamental Principles of Organic Chemistry	118
8.	Aliphatic Hydrocarbons	136
9.	Aromatic Hydrocarbons	169
10.	Alkyl Halides	194
11.	Alcohols, Phenols and Ethers	211
12.	Aldehydes and Ketones	228
13.	Carboxylic Acids	250
14.	Macromolecules	268
15.	Common Chemical Industries in Pakistan	291
16.	Environmental Chemistry	307
	Glossary	322
	Index	328

# PERIODIC TABLE OF THE ELEMENTS

**1**  
**H**  
**Hydrogen 1**  
• Rocket fuel  
• Hydrogenation of fats  
• Petroleum desulfurization  
• Water, ammonia  
x 1.0079  
1s<sup>1</sup>

**2**  
**Li**  
**Lithium 3**  
• Lubricant additive  
• Pacemaker batteries  
• Alloys used in space  
• Glass and pharmaceuticals  
x 6.941  
[He]2s<sup>1</sup>

**Na**  
**Sodium 11**  
• Street lights  
• Nuclear reactor coolant  
• Batteries  
• Kitchen salt, soda, glass  
x 22.990  
[Ne]3s<sup>1</sup>

**K**  
**Potassium 19**  
• Fertilizer  
• Glass lenses  
• Motor oil, gun power  
• Salt substitute  
x 39.098  
[Ar]4s<sup>1</sup>

**Rb**  
**Rubidium 37**  
• Photoelectric cells  
• Gas scavenger in vacuum tubes  
• Heart muscle research  
x 85.468  
[Kr]5s<sup>1</sup>

**Cs**  
**Cesium 55**  
• Photoelectric cells  
• Gamma radiation source  
• Atomic clock  
• Semiconductor components  
x 132.905  
[Xe]6s<sup>1</sup>

**Fr**  
**Francium 87**  
• Radioactive  
x 223  
[Rn]7s<sup>1</sup>

**Be**  
**Beryllium 4**  
• X-ray tube windows  
• Watch springs  
• Spaceframe tools  
• Best conducting ceramics  
x 9.01218  
[He]2s<sup>2</sup>

**Mg**  
**Magnesium 12**  
• Racing bikes  
• Airplanes  
• Bricks for freestates  
• Batteries, flares  
x 24.305  
[Ne]3s<sup>2</sup>

**Ca**  
**Calcium 20**  
• Metallurgy  
• Cable insulation, batteries  
• Fertilizer  
• Concrete, plaster of Paris  
x 40.08  
[Ar]4s<sup>2</sup>

**Sr**  
**Strontium 38**  
• Nuclear batteries in burys  
• Gamma radiation source  
• Phosphorescent paint  
• Fireworks (strontium)  
x 87.62  
[Kr]5s<sup>2</sup>

**Ba**  
**Barium 56**  
• Spark plugs  
• Gas scavenger in vacuum tubes  
• Cathodes  
• Fluorescent lamps  
x 137.33  
[Xe]6s<sup>2</sup>

**Ra**  
**Radium 88**  
• Radioactive  
x 226  
[Rn]7s<sup>2</sup>

**Sc**  
**Scandium 21**  
• Laser detectors  
• Large screen TVs  
• Stadium lighting  
x 44.956  
[Ar]3d<sup>1</sup>4s<sup>2</sup>

**Y**  
**Yttrium 39**  
• Color TV screens  
• Radar, lasers  
• Superconductors  
• Fireproof bricks  
x 88.906  
[Kr]4d<sup>1</sup>5s<sup>2</sup>

**La**  
**Lanthanum 57**  
• Lighter filaments  
• Battery electrodes  
• Cathode ray tubes  
• Camera lenses  
• Fluorescent lamps  
x 138.905  
[Xe]5d<sup>1</sup>6s<sup>2</sup>

**Ac**  
**Actinium 89**  
• Neutron source  
x 227  
[Rn]6d<sup>1</sup>7s<sup>2</sup>

**Unnilquadium 104**  
x (261)  
[Rn]5f<sup>14</sup>6d<sup>1</sup>7s<sup>2</sup>

**U**  
**Uranium 92**  
• Nuclear fuel  
• Gas scintillation counter  
• Nuclear reactor fuel  
• Gas scintillation counter  
x 238.029  
[Rn]5f<sup>3</sup>6d<sup>1</sup>7s<sup>2</sup>

**Ti**  
**Titanium 22**  
• Heat exchanger  
• Airplane motors  
• Springs  
• Jet engines  
• Pigments for paint and paper  
x 47.88  
[Ar]3d<sup>2</sup>4s<sup>2</sup>

**Zr**  
**Zirconium 40**  
• Nuclear fuel rods  
• Catalytic converters  
• Zircon gemstone  
• Furnace bricks  
x 91.224  
[Kr]4d<sup>2</sup>5s<sup>2</sup>

**Hf**  
**Hafnium 72**  
• Nuclear submarines  
• Control nuclear reactions  
• Gas scavenger in vacuum tubes  
x 178.49  
[Xe]4f<sup>14</sup>5d<sup>2</sup>6s<sup>2</sup>

**Unnilpentium 105**  
x (262)  
[Rn]5f<sup>14</sup>6d<sup>1</sup>7s<sup>2</sup>

**Th**  
**Thorium 90**  
• Gas scintillation counter  
• Nuclear reactor fuel  
• Gas scintillation counter  
x 232.038  
[Rn]6d<sup>2</sup>7s<sup>2</sup>

**Unnilhexium 106**  
x (263)  
[Rn]5f<sup>14</sup>6d<sup>2</sup>7s<sup>2</sup>

**V**  
**Vanadium 23**  
• Construction materials  
• Tools  
• Springs  
• Jet engines  
x 50.9415  
[Ar]3d<sup>3</sup>4s<sup>2</sup>

**Nb**  
**Niobium 41**  
• Cutting tools  
• Pipelines  
• Superconducting magnets  
• Welding rods  
x 92.9064  
[Kr]4d<sup>4</sup>5s<sup>1</sup>

**Ta**  
**Tantalum 73**  
• Capacitors  
• Vacuum tube filaments  
• Cutting tools  
• Weights  
x 180.948  
[Xe]4f<sup>14</sup>5d<sup>3</sup>6s<sup>2</sup>

**Unnilseptem 107**  
x (264)  
[Rn]5f<sup>14</sup>6d<sup>2</sup>7s<sup>2</sup>

**Pu**  
**Plutonium 94**  
• Nuclear fuel  
• Nuclear reactor fuel  
• Gas scintillation counter  
x 239.046  
[Rn]5f<sup>6</sup>6d<sup>1</sup>7s<sup>2</sup>

**Unniloctetium 108**  
x (265)  
[Rn]5f<sup>14</sup>6d<sup>3</sup>7s<sup>2</sup>

**Cr**  
**Chromium 24**  
• Plating for car parts  
• Tools, knives  
• Lasers, camouflage paints  
• Stereo, video tapes  
x 51.996  
[Ar]3d<sup>5</sup>4s<sup>1</sup>

**Mo**  
**Molybdenum 42**  
• Filament in electric heaters  
• Rocket motors  
• Lubricants  
• Source of radio isotopes  
x 95.94  
[Kr]4d<sup>5</sup>5s<sup>1</sup>

**W**  
**Tungsten 74**  
• Welding electrode  
• Lamp filaments, TV  
• Radiol sources  
• Cutting tools  
• X-ray tubes  
x 183.85  
[Xe]4f<sup>14</sup>5d<sup>4</sup>6s<sup>2</sup>

**Unnilennium 109**  
x (266)  
[Rn]5f<sup>14</sup>6d<sup>3</sup>7s<sup>2</sup>

**Am**  
**Americium 95**  
• Crystal research  
• Smoke detectors  
• Gas scintillation counter  
• Neutron source  
x 243  
[Rn]5f<sup>7</sup>7s<sup>2</sup>

**Unnilunium 110**  
x (267)  
[Rn]5f<sup>14</sup>6d<sup>4</sup>7s<sup>2</sup>

**Mn**  
**Manganese 25**  
• Steel for rail switches  
• Tools, axes  
• Saws, plows  
• Tin cans  
x 54.938  
[Ar]3d<sup>5</sup>4s<sup>2</sup>

**Tc**  
**Technetium 43**  
• Radiation source for medical research  
x (98)  
[Kr]4d<sup>5</sup>5s<sup>2</sup>

**Re**  
**Rhenium 75**  
• Oven filament  
• Jewelry plating  
• Radiol sources  
• Thermocouples  
x 186.207  
[Xe]4f<sup>14</sup>5d<sup>5</sup>6s<sup>2</sup>

**Unnilbium 111**  
x (268)  
[Rn]5f<sup>14</sup>6d<sup>4</sup>7s<sup>2</sup>

**Pm**  
**Promethium 61**  
• Nuclear batteries  
• Thickness gauge  
• Starter for fluorescent lights  
x (145)  
[Xe]4f<sup>6</sup>6s<sup>2</sup>

**Unniltrium 112**  
x (269)  
[Rn]5f<sup>14</sup>6d<sup>5</sup>7s<sup>2</sup>

**Fe**  
**Iron 26**  
• Bikes, cars, bridges  
• Magnets, machines  
• Hubs, tools  
• Tin cans  
x 55.847  
[Ar]3d<sup>6</sup>4s<sup>2</sup>

**Ru**  
**Ruthenium 44**  
• Eye treatment  
• Thickness meters for ophthalmology  
• Fountain pen points  
• Electrical contacts  
x 101.07  
[Kr]4d<sup>6</sup>5s<sup>1</sup>

**Os**  
**Osmium 76**  
• Decorations  
• Compass needles  
• Fountain pen points  
• Clock bearings  
x 190.23  
[Xe]4f<sup>14</sup>5d<sup>6</sup>6s<sup>2</sup>

**Unnilquadium 104**  
x (270)  
[Rn]5f<sup>14</sup>6d<sup>5</sup>7s<sup>2</sup>

**Sm**  
**Samarium 62**  
• Gamma radiation source  
• High temperature permanent magnets  
• Lasers  
x 150.36  
[Xe]4f<sup>6</sup>6s<sup>2</sup>

**Unnilpentium 105**  
x (271)  
[Rn]5f<sup>14</sup>6d<sup>5</sup>7s<sup>2</sup>

**Co**  
**Cobalt 27**  
• Gamma radiation source  
• Permanent magnet  
• Catalytic converters  
x 58.9332  
[Ar]3d<sup>7</sup>4s<sup>2</sup>

**Rh**  
**Rhodium 45**  
• Headlight reflectors  
• Telephone relays  
• Catalytic converters  
• Aircraft sparkplugs  
x 101.066  
[Kr]4d<sup>7</sup>5s<sup>1</sup>

**Ir**  
**Iridium 77**  
• Satellite transmitter  
• Hypodermic needles  
• Standard unit meter bar  
• Helicopter sparkplugs  
x 192.22  
[Xe]4f<sup>14</sup>5d<sup>7</sup>6s<sup>2</sup>

**Unnilseptem 107**  
x (272)  
[Rn]5f<sup>14</sup>6d<sup>6</sup>7s<sup>2</sup>

**Eu**  
**Europium 63**  
• Cathode ray tubes  
• Laser amplifier  
• X-ray tubes  
• Cathode ray tubes  
• X-ray tubes  
x 151.964  
[Xe]4f<sup>7</sup>6s<sup>2</sup>

**Unniloctetium 108**  
x (273)  
[Rn]5f<sup>14</sup>6d<sup>6</sup>7s<sup>2</sup>

**Ni**  
**Nickel 28**  
• Coins  
• Bikes, ovens, spoons  
• Crochets, white gold  
• Rechargeable batteries  
x 58.69  
[Ar]3d<sup>8</sup>4s<sup>2</sup>

**Pd**  
**Palladium 46**  
• Catalytic converters  
• Hydrogen separation  
• Dental crowns  
• Anti-tumor agents  
x 106.42  
[Kr]4d<sup>10</sup>

**Pt**  
**Platinum 78**  
• Catalyst for nitric acid prod.  
• Crucibles  
• Dental crowns  
• Anti-tumor agents  
x 195.08  
[Xe]4f<sup>14</sup>5d<sup>9</sup>6s<sup>1</sup>

**Unnilennium 109**  
x (274)  
[Rn]5f<sup>14</sup>6d<sup>7</sup>7s<sup>2</sup>

**Am**  
**Americium 95**  
• Crystal research  
• Smoke detectors  
• Gas scintillation counter  
• Neutron source  
x 243  
[Rn]5f<sup>7</sup>7s<sup>2</sup>

**Unnilunium 110**  
x (275)  
[Rn]5f<sup>14</sup>6d<sup>7</sup>7s<sup>2</sup>

**Cu**  
**Copper 29**  
• Cable, wire, water pipe  
• Razor blades  
• Statue of Liberty  
• Bulbs, cathodes  
x 63.546  
[Ar]3d<sup>10</sup>4s<sup>1</sup>

**Ag**  
**Silver 47**  
• Mirrors, batteries  
• Silverware  
• Photographic film and paper  
• Photoconductive glass  
x 107.868  
[Kr]4d<sup>10</sup>5s<sup>1</sup>

**Au**  
**Gold 79**  
• Precious metal  
• Jewelry  
• Electrical contacts  
• Dental crowns  
• Seed protection  
x 196.967  
[Xe]4f<sup>14</sup>5d<sup>10</sup>6s<sup>1</sup>

**Unnilbium 111**  
x (276)  
[Rn]5f<sup>14</sup>6d<sup>8</sup>7s<sup>2</sup>

**Cm**  
**Curium 96**  
• Neutron source  
x 247  
[Rn]5f<sup>7</sup>7s<sup>2</sup>

**Unniltrium 112**  
x (277)  
[Rn]5f<sup>14</sup>6d<sup>8</sup>7s<sup>2</sup>

**B**  
**Boron 5**  
• Regulator in nuclear plants  
• Tennis rackets  
• Heat resistant glass  
• Eye disinfectant  
x 10.81  
[He]2s<sup>2</sup>2p<sup>1</sup>

**Al**  
**Aluminium 13**  
• Window frames, doorcoats  
• Tubes, cable, foil  
• Fireworks, flash bulbs  
• Cars, trucks, planes  
x 26.9815  
[Ne]3s<sup>2</sup>3p<sup>1</sup>

**Ga**  
**Gallium 31**  
• Gallium thermometer  
• Computer memory  
• Transistors, laser diodes  
• Used to locate tumors  
x 69.723  
[Ar]3d<sup>10</sup>4s<sup>2</sup>4p<sup>1</sup>

**In**  
**Indium 49**  
• Solar cells, mirrors  
• Regulator in nuclear power  
• Photo cells, transistors  
• Blood and lung research  
x 114.818  
[Kr]4d<sup>10</sup>5s<sup>2</sup>5p<sup>1</sup>

**Tl**  
**Thallium 81**  
• Thermometer filling  
• Infrared detectors  
• Health muscle research  
• Electrical research  
x 204.383  
[Xe]4f<sup>14</sup>5d<sup>10</sup>6s<sup>2</sup>6p<sup>1</sup>

**Unnilquadium 104**  
x (278)  
[Rn]5f<sup>14</sup>6d<sup>9</sup>7s<sup>2</sup>

**C**  
**Carbon 6**  
• Diamond, graphite  
• Tire colorant, steel  
• Corrosion nuclear reactions  
• Plastics, life  
x 12.011  
[He]2s<sup>2</sup>2p<sup>2</sup>

**Si**  
**Silicon 14**  
• Micro chips, solar cells  
• Tools  
• Quartz, cement, glass  
• Silicone rubbers and oils  
x 28.0855  
[Ne]3s<sup>2</sup>3p<sup>2</sup>

**Ge**  
**Germanium 32**  
• Infrared night vision  
• Wide-angle lenses  
• Fiber optics  
• Dentistry  
x 72.630  
[Ar]3d<sup>10</sup>4s<sup>2</sup>4p<sup>2</sup>

**Sn**  
**Tin 50**  
• Coins, cups and plates  
• Infrared detectors  
• Optical glass, enamel  
• Washer resistant vinyl siding  
x 118.710  
[Kr]4d<sup>10</sup>5s<sup>2</sup>5p<sup>2</sup>

**Pb**  
**Lead 82**  
• Radiation protection  
• Roof covering, batteries  
• Solder, ammunition  
• Gasoline additives  
x 207.2  
[Xe]4f<sup>14</sup>5d<sup>10</sup>6s<sup>2</sup>6p<sup>2</sup>

**Unnilpentium 105**  
x (279)  
[Rn]5f<sup>14</sup>6d<sup>9</sup>7s<sup>2</sup>

**N**  
**Nitrogen 7**  
• Cryogenic surgery  
• Contact (liquid nitrogen)  
• Anesthesia production  
• Rocket fuel  
x 14.0064  
[He]2s<sup>2</sup>2p<sup>3</sup>

**P**  
**Phosphorus 15**  
• Fire works, matches  
• Fertilizers, detergents  
• Toothpastes  
• Permanent wave lotion  
x 30.9738  
[Ne]3s<sup>2</sup>3p<sup>3</sup>

**As**  
**Arsenic 33**  
• Shotgun pellets  
• Metal for alloys  
• Glass, lenses  
• Light emitting diodes-LED  
x 74.9216  
[Ar]3d<sup>10</sup>4s<sup>2</sup>4p<sup>3</sup>

**Sb**  
**Antimony 51**  
• Solder, type for printing  
• Lead isotopes  
• Battery plate material  
• Fire retardants  
• Ceramic glazes  
x 121.757  
[Kr]4d<sup>10</sup>5s<sup>2</sup>5p<sup>3</sup>

**Bi**  
**Bismuth 83**  
• Catalyst in rubber production  
• Fireworks  
• Fire retardants  
• X-ray tubes  
x 208.980  
[Xe]4f<sup>14</sup>5d<sup>10</sup>6s<sup>2</sup>6p<sup>3</sup>

**Unnilseptem 107**  
x (280)  
[Rn]5f<sup>14</sup>6d<sup>10</sup>7s<sup>2</sup>

**O**  
**Oxygen 8**  
• Combustion  
• Steel production  
• Water purification  
• Steel, water, cement  
x 15.9994  
[He]2s<sup>2</sup>2p<sup>4</sup>

**S**  
**Sulfur 16**  
• Matches, fireworks  
• Batteries  
• Vulcanization of rubber  
• Permanent wave lotion  
x 32.06  
[Ne]3s<sup>2</sup>3p<sup>4</sup>

**Se**  
**Selenium 34**  
• Light meters  
• Copy machines  
• Solar cells  
• Anti-backdraft shampoos  
x 78.96  
[Ar]3d<sup>10</sup>4s<sup>2</sup>4p<sup>4</sup>

**Te**  
**Tellurium 52**  
• Precision caps  
• Vulcanization of rubber  
• Battery plate material  
• Electrical research  
x 127.60  
[Kr]4d<sup>10</sup>5s<sup>2</sup>5p<sup>4</sup>

**Po**  
**Polonium 84**  
• Nuclear batteries  
• Research  
• Antineutrino research  
• Film developer  
x 209  
[Xe]4f<sup>14</sup>5d<sup>10</sup>6s<sup>2</sup>6p<sup>4</sup>

**Unniloctetium 108**  
x (281)  
[Rn]5f<sup>14</sup>6d<sup>10</sup>7s<sup>2</sup>

**F**  
**Fluorine 9**  
• Uranium enrichment  
• Refrigerator coolants  
• Toothpaste additive  
• Teflon  
x 18.9984  
[He]2s<sup>2</sup>2p<sup>5</sup>

**Cl**  
**Chlorine 17**  
• Water purification  
• Bleach, hydrochloric acid  
• Glass (PVC)  
• Soap removers  
x 35.453  
[Ne]3s<sup>2</sup>3p<sup>5</sup>

**Br**  
**Bromine 35**  
• Toner gas  
• Fire retardants  
• Disinfectants  
• Photographic film  
x 79.904  
[Ar]3d<sup>10</sup>4s<sup>2</sup>4p<sup>5</sup>

**I**  
**Iodine 53**  
• Disinfectants  
• Multivitamin supplements  
• X-ray contrast  
• Salt additive  
x 126.905  
[Kr]4d<sup>10</sup>5s<sup>2</sup>5p<sup>5</sup>

**At**  
**Astatine 85**  
• Sublimation in nature  
x 210  
[Xe]4f<sup>14</sup>5d<sup>10</sup>6s<sup>2</sup>6p<sup>5</sup>

**Unnilunium 110**  
x (282)  
[Rn]5f<sup>14</sup>6d<sup>10</sup>7s<sup>2</sup>

**2**  
**He**  
**Helium 2**  
• Balloons, blimps  
• Deep sea pressure  
• Lasers, low temperature  
• Nuclear energy research  
• Lenses  
x 4.0026  
1s<sup>2</sup>

**Ne**  
**Neon 10**  
• Neon signs  
• TV color tubes  
• Laser research  
• Fluorescent lamps  
x 20.179  
[He]2s<sup>2</sup>2p<sup>6</sup>

**Ar**  
**Argon 18**  
• Light bulbs  
• Gas discharge tubes  
• Lasers, laser systems  
• Welding inert gas  
x 39.948  
[Ne]3s<sup>2</sup>3p<sup>6</sup>

**Kr**  
**Krypton 36**  
• Fluorescent bulbs  
• Flash tubes  
• Wavelength standard  
• UV lasers  
x 83.80  
[Ar]3d<sup>10</sup>4s<sup>2</sup>4p<sup>6</sup>

**Xe**  
**Xenon 54**  
• UV lamps, ion lamps  
• Flash tubes  
• Projection lamps  
• Laser research  
x 131.29  
[Kr]4d<sup>10</sup>5s<sup>2</sup>5p<sup>6</sup>

**Rn**  
**Radon 86**  
• Radioactive  
• Gas scintillation counter  
• Nuclear reactor fuel  
• Gas scintillation counter  
x 222  
[Xe]4f<sup>14</sup>5d<sup>10</sup>6s<sup>2</sup>6p<sup>6</sup>

**Unniltrium 112**  
x (283)  
[Rn]5f<sup>14</sup>6d<sup>10</sup>7s<sup>2</sup>

## CHAPTER

# 1

## PERIODIC CLASSIFICATION OF ELEMENTS AND PERIODICITY

### In this chapter you will learn

1. To describe the periodic table in terms of groups and periods.
2. To describe and explain periodicity in physical and chemical properties.
3. To describe the position of hydrogen in the periodic table.

### 1.1 INTRODUCTION

To achieve a thorough understanding of a complex subject like chemistry, it would be highly desirable to fit all the facts into a simple logical pattern. The periodic table of elements has served the purpose to systematize the properties of the elements for well over 100 years. The development of periodic table is one of the most significant achievements in the history of chemical sciences. The Periodic Table provides a basic framework to study the periodic behaviour of physical and chemical properties of elements as well as their compounds.

In previous classes, you have learnt about the periodic classification of elements. This chapter describes in more detail the periodic table and the periodicity of elements.

#### 1.1.1 Historical Background

The early history of ideas leading up to the Periodic classification of elements is fascinating but will not be treated in detail. Those who made memorable contributions in this field are Al-Razi, Dobereiner, Newlands and Mendeleev. Al-Razi's classification was based on the physical and chemical properties of substances. Dobereiner, a German chemist in 1829, arranged then known elements in group called Triads, as each contained three elements with similar properties. Newlands who was an English chemist, in 1864, classified 62 elements, known at that time, in increasing order of their atomic masses. He noticed that every eighth element had some properties in common with the first one. The principle on which this classification is based was called the Law of Octaves.

In 1871, a Russian Chemist, **Dmitri Mendeleev**, gave a more useful and comprehensive scheme for the classification of elements. He presented the first regular periodic table in which

elements of similar chemical properties were arranged in eight vertical columns called Groups. The horizontal rows of the table were called Periods. Mendeleev also started by arranging the elements in ascending order of their atomic masses and found that elements having similar chemical properties appeared at regular intervals. This significant observation was called Periodic Law. Mendeleev left some gaps in his table for elements, which had not yet been discovered, and by considering their positions in the periodic table, he predicted properties of these elements. For example, germanium was not known at that time, but Mendeleev was confident that this element must exist so he predicted its properties. A few years later, germanium was indeed discovered and a remarkable agreement was found with Mendeleev's predictions.

### 1.1.2 Improvements in Mendeleev's Periodic Table

In order to make the periodic table more useful and accurate, a few improvements were made in Mendeleev's periodic table. After the discovery of atomic number by Moseley in 1911, it was noticed that elements could be classified more satisfactorily by using their atomic numbers, rather than their atomic masses. Hence, the periodic table was improved by arranging the elements in ascending order of their atomic numbers instead of their atomic masses. This improvement rectified a number of confusions present in the old periodic table. The modern Periodic Law states that: "if the elements are arranged in ascending order of their atomic numbers, their chemical properties repeat in a periodic manner".

Another improvement was the addition of an extra group (group VIII A) at the extreme right of the periodic table. This group contains noble gases, which had not been discovered in Mendeleev's time.

Another confusion in Mendeleev's table was that elements like Be, Mg, Ca, Sr, Ba and Zn, Cd, Hg were placed in a single vertical group, while according to their properties they belonged to two different categories. The same was true for so many other elements placed in the same vertical group. In modern periodic table, the confusion was removed by dividing the elements in two types of vertical groups, A and B. In modern periodic table, Be, Mg, Ca, Sr and Ba are placed in group IIA and Zn, Cd, Hg in group IIB.

## 1.2 THE MODERN PERIODIC TABLE

In modern periodic table (see periodic table) all the elements are arranged in ascending order of their atomic numbers. Followings are the essential features of the periodic table.

### 1. Groups and Periods

Elements with similar properties are placed in vertical columns called Groups. There are eight groups, which are usually numbered by Roman numerals I to VIII. Each group is divided into two subgroups, designated as A and B subgroup. The subgroups, containing the representative or normal elements are labelled as A subgroup, whereas B subgroups contain less typical elements, called transition elements and are arranged in the centre of the periodic table. The horizontal rows of the periodic table are called Periods. The essential features of periods are as follows:

Table 1.1  
MODERN PERIODIC TABLE OF THE ELEMENTS

Atomic Number																		Atomic Mass																																																																																																																																																																																																																																																																																																																																																																																																																																																																																																																																																																																																																																			
← New proposal of IUPAC																		← Old proposal of IUPAC																																																																																																																																																																																																																																																																																																																																																																																																																																																																																																																																																																																																																																			
18																		0 or VIIIA																																																																																																																																																																																																																																																																																																																																																																																																																																																																																																																																																																																																																																			
Noble GASES																		Metals																		Non Metals																		Metalloids																																																																																																																																																																																																																																																																																																																																																																																																																																																																																																																																																																																															
He																		Ne																		Ar																		Kr																		Xe																		Rn																																																																																																																																																																																																																																																																																																																																																																																																																																																																																																																																																											
2																		10																		8																		6																		4																		2																																																																																																																																																																																																																																																																																																																																																																																																																																																																																																																																																											
He																		Ne																		Ar																		Kr																		Xe																		Rn																																																																																																																																																																																																																																																																																																																																																																																																																																																																																																																																																											
17																		16																		15																		14																		13																		12																		11																		10																		9																		8																		7																		6																		5																		4																		3																		2																		1																																																																																																																																																																																																																																																																																																																																																					
VIIA																		VIA																		VA																		IVA																		IIIA																		IIB																		IB																		I																		IIA																		IA																																																																																																																																																																																																																																																																																																																																																																																																																																																																																			
F																		O																		N																		C																		B																		Zn																		Cu																		Ni																		Co																		Fe																		Mn																		Cr																		V																		Ti																		Sc																		Ca																		K																		Na																		Mg																		Be																		Li																		H																																																																																																																																																																																																																																																											
Fluorine																		Oxygen																		Nitrogen																		Carbon																		Boron																		Zinc																		Copper																		Nickel																		Cobalt																		Iron																		Manganese																		Chromium																		Vanadium																		Titanium																		Scandium																		Calcium																		Potassium																		Sodium																		Magnesium																		Beryllium																		Lithium																		Hydrogen																																																																																																																																																																																																																																																											
9																		8																		7																		6																		5																		30																		29																		28																		27																		26																		25																		24																		23																		22																		21																		20																		19																		18																		17																		16																		15																		14																		13																		12																		11																		10																		9																		8																		7																		6																		5																		4																		3																		2																		1																	
F																		O																		N																		C																		B																		Zn																		Cu																		Ni																		Co																		Fe																		Mn																		Cr																		V																		Ti																		Sc																		Ca																		K																		Na																		Mg																		Be																		Li																		H																																																																																																																																																																																																																																																											
Fluorine																		Oxygen																		Nitrogen																		Carbon																		Boron																		Zinc																		Copper																		Nickel																		Cobalt																		Iron																		Manganese																		Chromium																		Vanadium																		Titanium																		Scandium																		Calcium																		Potassium																		Sodium																		Magnesium																		Beryllium																		Lithium																		Hydrogen																																																																																																																																																																																																																																																											
9																		8																		7																		6																		5																		30																		29																		28																		27																		26																		25																		24																		23																		22																		21																		20																		19																		18																		17																		16																		15																		14																		13																		12																		11																		10																		9																		8																		7																		6																		5																		4																		3																		2																		1																	
F																		O																		N																		C																		B																		Zn																		Cu																		Ni																		Co																		Fe																		Mn																		Cr																		V																		Ti																		Sc																		Ca																		K																		Na																		Mg																		Be																		Li																		H																																																																																																																																																																																																																																																											
Fluorine																		Oxygen																		Nitrogen																		Carbon																		Boron																		Zinc																		Copper																		Nickel																		Cobalt																		Iron																		Manganese																		Chromium																		Vanadium																		Titanium																		Scandium																		Calcium																		Potassium																		Sodium																		Magnesium																		Beryllium																		Lithium																		Hydrogen																																																																																																																																																																																																																																																											
9																		8																		7																		6																		5																		30																		29																		28																		27																		26																		25																		24																		23																		22																		21																		20																		19																		18																		17																		16																		15																		14																		13																		12																		11																		10																		9																		8																		7																		6																		5																		4																		3																		2																		1																	
F																		O																		N																		C																		B																		Zn																		Cu																		Ni																		Co																		Fe																		Mn																		Cr																		V																		Ti																		Sc																		Ca																		K																		Na																		Mg																		Be																		Li																		H																																																																																																																																																																																																																																																											
Fluorine																		Oxygen																		Nitrogen																		Carbon																		Boron																		Zinc																		Copper																		Nickel																		Cobalt																		Iron																		Manganese																		Chromium																		Vanadium																		Titanium																		Scandium																		Calcium																		Potassium																		Sodium																		Magnesium																		Beryllium																		Lithium																		Hydrogen																																																																																																																																																																																																																																																											
9																		8																		7																		6																		5																		30																		29																		28																		27																		26																		25																		24																		23																		22																		21																		20																		19																		18																		17																		16																		15																		14																		13																		12																		11																		10																		9																		8																		7																		6																		5																		4																		3																		2																		1																	
F																		O																		N																		C																		B																		Zn																		Cu																		Ni																		Co																		Fe																		Mn																		Cr																		V																		Ti																		Sc																		Ca																		K																		Na																		Mg																		Be																		Li																		H																																																																																																																																																																																																																																																											
Fluorine																		Oxygen																		Nitrogen																		Carbon																		Boron																		Zinc																		Copper																		Nickel																		Cobalt																		Iron																		Manganese																		Chromium																		Vanadium																		Titanium																		Scandium																		Calcium																		Potassium																		Sodium																		Magnesium																		Beryllium																		Lithium																		Hydrogen																																																																																																																																																																																																																																																											
9																		8																		7																		6																		5																		30																		29																		28																		27																		26																		25																		24																		23																		22																		21																		20																		19																		18																		17																		16																		15																		14																		13																		12																		11																		10																		9																		8																		7																		6																		5																		4																		3																		2																		1																	
F																		O																		N																		C																		B																		Zn																		Cu																		Ni																		Co																		Fe																		Mn																		Cr																		V																		Ti																		Sc																		Ca																		K																		Na																		Mg																		Be																		Li																		H																																																																																																																																																																																																																																																											
Fluorine																		Oxygen																		Nitrogen																		Carbon																		Boron																		Zinc																		Copper																		Nickel																		Cobalt																		Iron																		Manganese																		Chromium																		Vanadium																		Titanium																		Scandium																		Calcium																		Potassium																		Sodium																		Magnesium																		Beryllium																		Lithium																		Hydrogen																																																																																																																																																																																																																																																											
9																		8																		7																		6																		5																		30																		29																		28																		27																		26																		25																		24																		23																		22																		21																		20																		19																		18																		17																		16																		15																		14																		13																		12																		11																		10																		9																		8																		7																		6																		5																		4																		3																		2																		1																	
F																		O																		N																		C																		B																		Zn																		Cu																		Ni																		Co																		Fe																		Mn																		Cr																		V																		Ti																		Sc																		Ca																		K																		Na																		Mg																		Be																		Li																		H																																																																																																																																																																																																																																																											
Fluorine																		Oxygen																		Nitrogen																		Carbon																		Boron																		Zinc																		Copper																		Nickel																		Cobalt																		Iron																		Manganese																		Chromium																		Vanadium																		Titanium																		Scandium																		Calcium																		Potassium																		Sodium																		Magnesium																		Beryllium																		Lithium																		Hydrogen																																																																																																																																																																																																																																																											
9																		8																		7																		6																		5																		30																		29																		28																		27																		26																		25																		24																		23																		22																		21																		20																		19																		18																		17																		16																		15																		14																		13																		12																		11																		10																		9																		8																		7																		6																		5																		4																		3																		2																		1																	
F																		O																		N																		C																		B																		Zn																		Cu																		Ni																		Co																		Fe																		Mn																		Cr																		V																		Ti																		Sc																		Ca																		K																		Na																		Mg																		Be																		Li																		H																																																																																																																																																																																																																																																											
Fluorine																		Oxygen																		Nitrogen																		Carbon																		Boron																		Zinc																		Copper																		Nickel																		Cobalt																		Iron																		Manganese																		Chromium																		Vanadium																		Titanium																		Scandium																		Calcium																		Potassium																		Sodium																		Magnesium																		Beryllium																		Lithium																		Hydrogen																																																																																																																																																																																																																																																											
9																		8																		7																		6																		5																		30																		29																		28																		27																		26																		25																		24																		23																		22																		21																		20																		19																		18																		17																		16																		15																		14																		13																		12																		11																		10																		9																		8																		7																		6																		5																		4																		3																		2																		1																	
F																		O																		N																		C																		B																		Zn																		Cu																		Ni																		Co																		Fe																		Mn																		Cr																		V																		Ti																		Sc																		Ca																		K																		Na																		Mg																		Be																		Li																		H																																																																																																																																																																																																																																																											
Fluorine																		Oxygen																		Nitrogen																		Carbon																		Boron																		Zinc																		Copper																		Nickel																		Cobalt																		Iron																		Manganese																		Chromium																		Vanadium																		Titanium																		Scandium																		Calcium																		Potassium																		Sodium																		Magnesium																		Beryllium																		Lithium																		Hydrogen																																																																																																																																																																																																																																																											
9																		8																		7																		6																		5																		30																		29																		28																		27																		26																		25																		24																		23																		22																		21																		20																		19																		18																		17																		16																		15																		14																		13																		12																		11																		10																		9																		8																		7																		6																		5																		4																		3																		2																		1																	
F																		O																		N																		C																		B																		Zn																		Cu																		Ni																		Co																		Fe																		Mn																		Cr																		V																		Ti																		Sc																		Ca																		K																		Na																		Mg																		Be																		Li																		H																																																																																																																																																																																																																																																											
Fluorine																		Oxygen																		Nitrogen																		Carbon																		Boron																		Zinc																		Copper																		Nickel																		Cobalt																		Iron																		Manganese																		Chromium																		Vanadium																		Titanium																		Scandium																		Calcium																		Potassium																		Sodium																		Magnesium																		Beryllium																		Lithium																		Hydrogen																																																																																																																																																																																																																																																											
9																		8																		7																		6																		5																		30																		29																		28																		27																		26																		25																		24																		23																		22																		21																		20																		19																		18																		17																		16																		15																		14																		13																		12																		11																		10																		9																		8																		7																		6																		5																		4																		3																		2																		1																	
F																		O																		N																		C																		B																		Zn																		Cu																		Ni																		Co																		Fe																		Mn																		Cr																		V																		Ti																		Sc																		Ca																		K																		Na																		Mg																		Be																		Li																		H																																																																																																																																																																																																																																																											
Fluorine																		Oxygen																		Nitrogen																		Carbon																		Boron																		Zinc																		Copper																		Nickel																		Cobalt																		Iron																		Manganese																		Chromium																		Vanadium																		Titanium																		Scandium																		Calcium																		Potassium																		Sodium																		Magnesium																		Beryllium																		Lithium																		Hydrogen																																																																																																																																																																																																																																																											
9																		8																		7																		6																		5																		30																		29																		28																		27																		26																		25																		24																		23																		22																		21																		20																		19																		18																		17																		16																		15																		14																		13																		12																		11																		10																		9																		8																		7																		6																		5																		4																		3																		2																		1																	
F																		O																		N																		C																		B																		Zn																		Cu																		Ni																		Co																		Fe																		Mn																		Cr																		V																		Ti																		Sc																		Ca																		K																		Na																		Mg																		Be																		Li																		H																																																																																																																																																																																																																																																											
Fluorine																		Oxygen																		Nitrogen																		Carbon																		Boron																		Zinc																		Copper																		Nickel																		Cobalt																		Iron																		Manganese																		Chromium																		Vanadium																		Titanium																		Scandium																		Calcium																		Potassium																		Sodium																		Magnesium																		Beryllium																		Lithium																		Hydrogen																																																																																																																																																																																																																																																											
9																		8																		7																		6																		5																		30																		29																		28																		27																		26																		25																		24																		23																		22																		21																		20																		19																		18																		17																		16																		15																		14																		13																		12																		11																		10																		9																		8																		7																		6																		5																		4																		3																		2																		1																	
F																		O																		N																		C																		B																		Zn																		Cu																		Ni																		Co																		Fe																		Mn																		Cr																		V																		Ti																		Sc																		Ca																		K																		Na																																																																																																																																																																																																																																																																																																																																			

- a) There are 7 periods in the periodic table numbered by Arabic numerals 1 to 7.
- b) The period 1 contains only two elements, hydrogen and helium.
- c) The periods 2 and 3 contain eight elements each and are called short periods. All the elements in these periods are representative elements and belong to A subgroup. In these periods, every eighth element resembles in properties with the first element. As lithium and beryllium in the 2nd period resemble in most of their properties with sodium and magnesium of the 3rd period, respectively. Similarly, boron and aluminium both show oxidation state of +3, fluorine in 2nd period has close resemblances with chlorine of 3rd period.
- d) The periods 4 and 5 are called long periods. Each long period consists of eighteen elements. Out of these, eight are representative elements belonging to A subgroup similar to second and third periods. Whereas the other ten elements, placed in the centre of the table belong to B subgroups and are known as transition elements. In these periods, the repetition of properties among the elements occurs after 18 elements. As after  ${}_{19}\text{K}$  (having atomic number 19) the next element with similar properties is  ${}_{37}\text{Rb}$ .
- e) The period 6 is also a long period, which contains thirty two elements. In this period there are eight representative elements, ten transition elements and a new set of fourteen elements called Lanthanides as they start after  ${}_{57}\text{La}$ . Lanthanides have remarkably similar properties and are usually shown separately at the bottom of the periodic table.
- f) The period 7 is incomplete so far. It contains only two normal elements  ${}_{87}\text{Fr}$  and  ${}_{88}\text{Ra}$ , ten transition elements and fourteen inner transition elements. The inner transition elements of this period are called Actinides, as they follow  ${}_{88}\text{Ac}$ . The actinides are also shown at the bottom of the periodic table under the Lanthanides. Due to their scarcity, the inner transition elements are also called rare earth elements.

## 2. Some More Families in the Periodic Table:

While studying about periods you have noticed that certain rows of elements with similar properties have assigned common names such as transition elements, Lanthanides, Actinides or Rare Earth elements. Similarly, due to their peculiar characteristics, some typical elements belonging to sub-group A, have also been assigned family names. For example, elements of the group IA are called Alkali Metals, because of their property to form strong alkalis with water.



Similarly, due to their presence in Earth's crust and alkaline character, the elements of group IIA are known as Alkaline Earth Metals. Another important family in the periodic table is Halogen family. The name "Halogens" is given to the elements of group VIIA, due to their salt forming properties. As the gases of group VIIIA are least reactive they are called "Noble Gases". These family names are useful for a quick recognition of an element in the periodic table.

### 3. Blocks in the Periodic Table

Elements in the periodic table can also be classified into four blocks. This classification is based upon the valence orbital of the element involved in chemical bonding. According to this classification, elements of IA and IIA subgroups are called s-block elements because their valence electrons are available in s orbital. The elements of IIIA to VIIIA subgroups (except He) are known as p-block elements as their valence electrons are present in p orbital. Similarly in transition elements, electrons in d-orbital are responsible for their valency hence they are called d-block elements. For Lanthanides and Actinides valence electrons are present in f-orbital hence these elements are called f-block elements. This classification is quite useful in understanding the chemistry of elements and predicting their properties especially the concept of valency or oxidation state.

### 4. Metals, Non-metals and Metalloids

Another basis for classifying the elements in the periodic table is their metallic character. Generally, the elements on the left hand side, in the centre and at the bottom of the periodic table are metals, while the non-metals are in the upper right corner of the table. Some elements, especially lower members of groups, IIIA, IVA and VA (as shown in Table 1.1) have properties of both metals as well as non-metals. These elements are called semi-metals or metalloids. In the periodic table elements of groups IVA to VIIIA, at the top right hand corner above the stepped line, are non-metals. The elements just under the "steps" such as Si, As, and Te are the metalloids. All the remaining elements, except hydrogen, are metals.

## 1.3 PERIODIC TRENDS IN PHYSICAL PROPERTIES

As you have studied so far that in modern periodic table the elements are arranged in ascending order of their atomic numbers and their classification in groups and periods is based on the similarity in their properties. Yet, due to the gradual increase in the number of protons in the nucleus and electrons in outer shells the physical and chemical properties of the elements steadily vary within a group or a period. Here, we study some trends in physical properties.

### 1. ATOMIC SIZE

#### a) Atomic Radius:

Atoms are so small that it is impossible to see an atom even with a powerful optical microscope. The size of a single atom therefore cannot be directly measured. However, techniques have been developed which can measure the distance between the centres of two bonded atoms of any element. Half of this distance is considered to be the radius of the atom.

In the periodic table, the atomic radius increases from top to bottom within a group due to increase in atomic number. This is because of the addition of an extra shell of electrons in each period. In a period, however, as the atomic number increases from left to right, the atomic radius decreases. This gradual decrease in the radius is due to increase in the positive charge in the nucleus. As the positive nuclear charge increases, the negatively charged electrons in the shells are pulled closer to the nucleus. Thus, the size of the outermost shell becomes gradually smaller.

This effect is quite remarkable in the elements of longer periods in which "d" and "f" subshells are involved. For example, the gradual decrease in the size of Lanthanides is significant and called Lanthanide Contraction.

### b) Ionic Radius:

When a neutral atom loses one or more electrons, it becomes a positive ion. The size of the atom is decreased in this process because of the two reasons. First the removal of one or more electrons from a neutral atom usually results in the loss of the outermost shell and second, the removal of electrons causes an imbalance in proton-electron ratio. Due to the greater attraction of the nuclear charge, the remaining electrons of the ion are drawn closer to the nucleus. Thus, a positive ion is always smaller than the neutral atom from which it is derived. The radius of Na is 186 pm and the radius of  $\text{Na}^+$  is 102 pm. On the contrary, a negative ion is always bigger than its parent atom. The reason is that addition of one or more electrons in the shell of a neutral atom enhances repulsion between the electrons causing expansion of the shell. Thus, the radius of fluorine atom is 72 pm and that of the fluoride ion ( $\text{F}^-$ ) is 133 pm.

In a group of the periodic table, similar charged ions increase in size from top to bottom. Whereas within a period, isoelectronic positive ions show a decrease in ionic radius from left to right, because of the increasing nuclear charge. The same trend is observed for the isoelectronic negative ions of a period; ionic size decrease from left to right. The variations in atomic and ionic radii of alkali metals and halogens are shown in Fig 1.1 and Fig.1.2.

### 2. Ionization Energy

The ionization energy of an element is the minimum quantity of energy which is required to remove an electron from the outermost shell of its isolated gaseous atom in its ground state. The ionization energy of sodium is  $496 \text{ kJ mol}^{-1}$ .



$$\text{I.E} = 496 \text{ kJ mol}^{-1}$$

Elements with greater number of electrons have more than one values of ionization

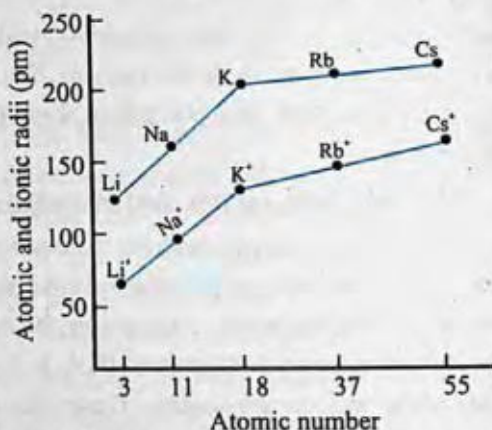

Fig. 1.1 Atomic and ionic radii of alkali metals

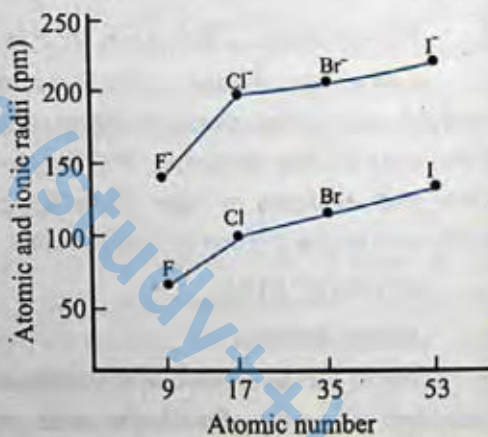
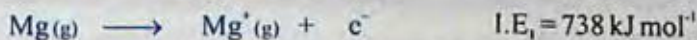
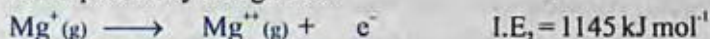

Fig. 1.2 Atomic and ionic radii of halogens

energy. So for magnesium, the first ionization energy value is the energy required to remove the first electron:



Similarly, the second ionization energy value is the energy required to remove the second electron from a positively charged ion.



### a) Variation Within a Group:

The factors upon which the ionization energy of an atom mainly depends are magnitude of nuclear charge, size of the atom, and the "shielding effect". The shielding effect is actually the repulsion due to electrons in between the nucleus and the outermost shell. This effect increases, as the size of the atom increases due to addition of an extra shell successively in each period hence more number of electrons *shields* the nucleus. Going down in a group, the nuclear charge increases but as the size of the atom and the number of electrons causing the shielding effect also increases therefore ionization energy decreases from top to bottom. That is why in alkali metals, for example, it is easier to remove an electron from caesium atom than from lithium atom. The change in ionization energies of IA elements is shown in Fig. 1.3.

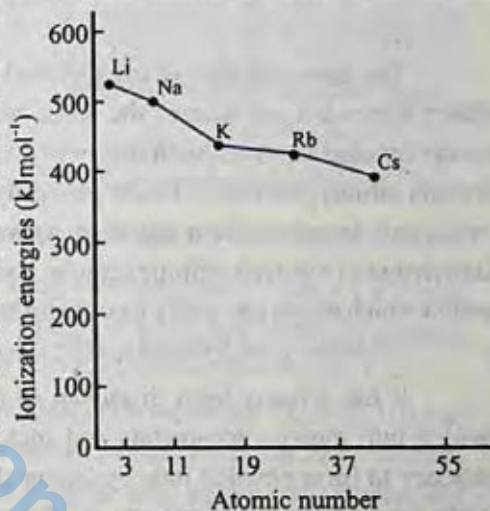

Fig. 1.3 Ionization energies of alkali metals

### b) Variation Across a Period:

Generally, smaller the atom with greater nuclear charge, more strongly the electrons are bound to the nucleus and hence higher the ionization energy of the atom. By moving from left to right in a period, the outer shell remains the same, while the nuclear charge increases effectively that makes the removal of an electron difficult and hence the value of ionization energy increases. Although, the number of electrons also increases in this case but the shielding is not very effective within the same shell. The trend of ionization energies of short periods is shown in Fig. 1.4. The figure also reveals that inert gases have the highest values of ionization energy because due to complete outermost shell in them, the removal of electron is extremely difficult.

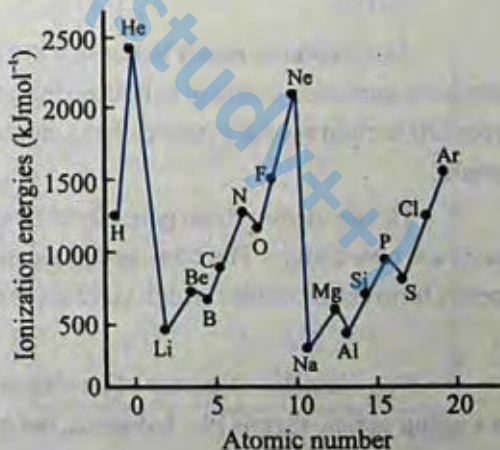

Fig. 1.4 Ionization energies of elements of short periods

### 3. Electron Affinity (E.A.)

The electron affinity is the energy released or absorbed, when an electron is added to a gaseous atom to form a negative ion.



Energy is usually released when electronegative elements absorb the first electron and E.A. in such cases is expressed in negative figures, as in the case of halogens. When a second electron is added to a uninegative ion, the incoming electron is repelled by the already present negative charge and energy is absorbed in this process.

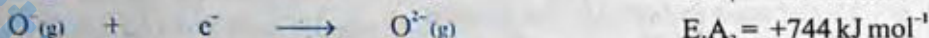
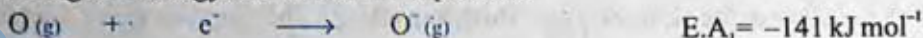

The absorbed energy is expressed as the electron affinity in positive figures. Electron affinity depends upon size of the atom, nuclear charge and vacancies in the outermost shell. Relatively smaller atoms with one or two vacancies in the outermost shell show large values of electron affinity. Electron affinity generally increases with increasing atomic number within a period and decreases from lighter to heavier elements in a given group of the periodic table. Knowledge of electron affinities can be combined with the knowledge of ionization energies to predict which atoms can easily lose electrons and which can accept electrons more readily.

### 4. Metallic and Non-Metallic Character

It has already been discussed in this chapter that elements of periodic table can be divided into metals, non-metals and metalloids. Chemically all the elements which have a tendency to form positive ions by losing electrons are considered metals. All metals are good conductor of heat and electricity. A characteristic property of metals is that they form basic oxides which give bases when dissolved in water.

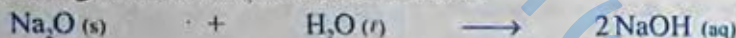

As it becomes easier to remove the electron of an atom bigger in size, therefore metallic character increases from top to bottom in a given group of elements. On the contrary, it decreases from left to right across a period. The elements of group VIIA (the halogens) are least metallic in nature.

The elements which gain electrons and form negative ions are called non-metals. All the gases are non-metals. The non-metals are normally poor conductor of heat and electricity. Non-metals form acidic oxides which yield acids on dissolving in water.



Non-metallic character of an element, decreases as the atomic size increases. Therefore in a group of non-metals like halogens, the non-metallic character decreases from top to bottom. The member at the top, fluorine, is the most non-metallic element of the periodic table. This trend can also be verified in the elements of groups VA and VIA. Nitrogen and oxygen are pure non-metals and usually exist in gaseous state while bismuth and polonium, the members at the bottom of these groups, are fairly metallic in nature.

## 5. Melting and Boiling Points

Melting and boiling points of elements tell us something about how strong the atoms or molecules in them are bound together.

### (a) Variation in a Period

Across the short periods, the melting and boiling points of elements increase with the number of valence electrons upto group IVA and then decrease upto the noble gases. The melting points of group IA elements are low because each atom in them provides only one electron to form a bond with other atom. Melting points of group IIA elements are considerably higher than those of group IA elements because each atom in them provides two binding electrons.

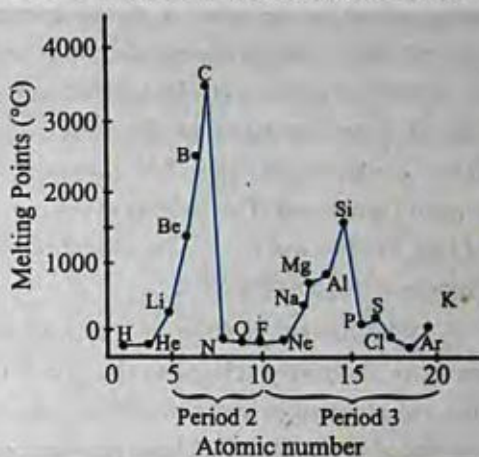

Fig. 1.5 Variation of melting points with atomic number

Since carbon has the maximum number of binding electrons, thus it has a very high melting point in diamond in which each carbon is bound to four other carbon atoms. In general, the elements which exist as giant covalent structures have very high melting points, Fig. 1.5.

An important change occurs when we move from group IVA to groups VA, VIA, VIIA as the lighter elements of these groups exist as small, covalent molecules, rather than as three dimensional lattices. For instance, nitrogen, oxygen and fluorine exist as individual molecules which have very weak intermolecular forces between them. Consequently, their melting and boiling points are extremely low.

### (b) Variation in a Group

The melting and boiling points of IA and IIA group elements decrease from top to bottom due to the increase in their atomic sizes. The binding forces present between large sized atoms are relatively weaker as compared to those between smaller atoms, Fig. 1.6.

For elements of group VIIA, which exist in the form of molecules, the melting and boiling points increase down the group, Fig. 1.7. This is because large molecules exert stronger force of attraction due to their higher polarizabilities.

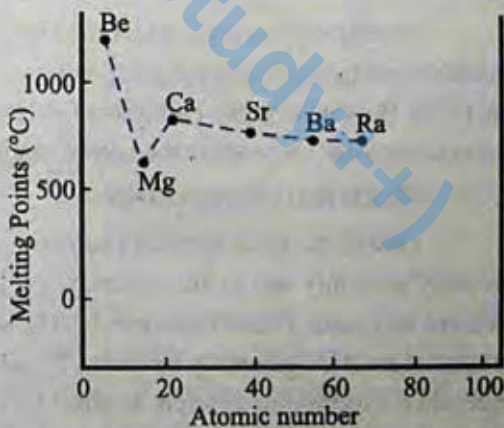

Fig.1.6 Melting points of Group IIA elements

## 6. Oxidation State

The oxidation state of an atom in a compound is defined as the apparent charge (with the

sign), which it would carry in the compound. In ionic compounds, it is usually the number of electrons gained or lost by the atom. As in the case of sodium chloride, the oxidation states of sodium and chlorine are +1 and -1, respectively. In covalent compounds, it is decided on the basis of the difference in their relative electronegativities. For example,  $\text{SnCl}_4$  is a covalent compound. The oxidation state of tin is +4 and that of chlorine is -1. The oxidation state of an element is zero in its free state.

The oxidation state of a typical element is directly or indirectly related to the group number to which the element belongs in the periodic table. The elements of group IA to IVA have the same oxidation states as their group numbers are. Just as B, Al and Ga belong to group IIIA, hence, they always show oxidation state of +3. So, for the elements of these groups, the oxidation state is same as the number of electrons present in the valence shells of the elements. However, for the elements of group VA, the oxidation states are either the number of electrons present in the valence shell (which is same as their group number) or the number of vacancies available in these shells. For example, N, P, As and Sb frequently show +3 as well as +5 oxidation states. Elements of group VIA show almost similar behaviour. In  $\text{H}_2\text{SO}_4$ , sulphur shows the oxidation state of +6, which is the number of electrons in its outermost shell whereas its oxidation state is -2 in  $\text{H}_2\text{S}$ , which is the number of vacancies in the shell. In group VIIA elements oxidation state is mostly -1, which is again the number of vacancies in their outermost shells. Group VIIIA elements, which are also called zero group elements, usually show zero oxidation state because there is no vacancy in their outermost shells.

Transition elements, which are shown in B subgroups of the periodic table, also show the oxidation states equal to their group number as it can be seen for Cu(I), Zn(II), V(V), Cr(VI) and Mn (VII). But due to greater number of valence electrons available in partly filled d-orbitals these elements usually, show more than one oxidation states in their compounds.

## 7. Electrical Conductance

One of the most familiar properties of metals is their ability to conduct electricity. This property is mainly due to the presence of relatively loose electrons in the outermost shell of the element and ease of their movement in the solid lattice. The electrical conductance of metals in groups IA and IIA, generally increases from top to bottom. However, the trend is not free from the individual variation in different atoms. Metals of group IB, which are known as coinage metals, have extraordinary high values of electrical conductance. Non-metals, on the other hand, especially of groups VIA and VIIA, show such low electrical conductance that they can be considered as bad conductors or insulators.

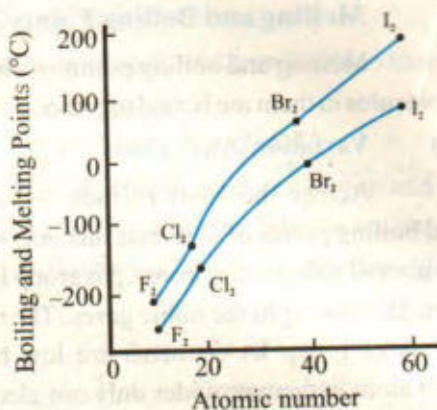
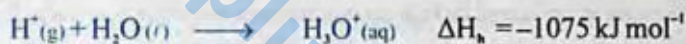

Fig. 1.7 Boiling (—) and melting points (---) of halogens

In the series of transition metals, the values of electrical conductance vary so abruptly that no general trend can be assigned to them. Carbon, in the form of diamond is non-conductor because all of its valence electrons are tetrahedrally bound and unable to move freely, while in the form of graphite, carbon is fairly good conductor because one of its four valence electrons is relatively free to move. The lower elements of group IVA, tin and lead, are fairly good conductors and their values of electrical conductivity are comparable with those of their counterparts in group IA.

## 8. Hydration Energy

The hydration energy is the heat absorbed or evolved when one mole of gaseous ions dissolve in water to give an infinitely dilute solution. For example, when one mole of gaseous hydrogen ions are dissolved in water resulting an infinitely dilute solution, a large amount of heat is liberated:



Hydration energies of a few negative and positive ions are shown in the Table 1.2.

It is evident from the table that hydration energies highly depend upon charge to size ratio of the ions. For a given set of ions, for example of group IA, charge to size ratio decreases from top to bottom in a group, the hydration energy also decreases in the same fashion. On the contrary, the hydration energy increases significantly on moving from left to right in a period as the charge to size ratio increases, as found in the metal ions of third period.

Table 1.2 Hydration Energies of Ions

Ion	$H_{\text{h}}$ $\text{kJ mol}^{-1}$
$\text{Li}^+$	-510
$\text{Na}^+$	-410
$\text{K}^+$	-336
$\text{Mg}^{2+}$	-1903
$\text{Ca}^{2+}$	-1591
$\text{Al}^{3+}$	-4613
$\text{F}^-$	-431
$\text{Cl}^-$	-313
$\text{Br}^-$	-284
$\text{I}^-$	-247

## 1.4 PERIODIC RELATIONSHIP IN COMPOUNDS

### a) Halides:

Halides are the binary compounds which halogens form with other elements. The physical properties of halides are largely determined by the nature of bonding present in them. On this basis, halides can be classified into two general classes: ionic and covalent. In between the two, there is another class of halides in which the halogen atom acts as a bridge between the two atoms of the other element, such halides are termed as "Polymeric" halides. Strongly electropositive elements, having greater electronegativity difference with halogen atom, form ionic halides. The halides of group IA are considered purely ionic compounds, which are high melting point solids. Such halides have three-dimensional lattices consisting of discrete ions. Among the pure ionic compounds, the fluorides have the highest lattice energies due to the small size of fluoride ion. Thus for ionic halides, the fluorides have the highest melting and boiling points which decrease in the order: fluoride > chloride > bromide > iodide.

Less electropositive elements, such as Be, Ga and Al form polymeric halides having partly ionic bonding with layer or chain lattices. The lattice of  $\text{SiCl}_4$  consists of discrete molecules, which are highly polar. The bonds in  $\text{PCl}_3$  and  $\text{S}_2\text{Cl}_2$  are less polar than those of  $\text{SiCl}_4$ . On moving across the periodic table from left to right, the electronegativity difference decreases and the trend shifts towards covalent halides. The gradual change in bond type and melting points of the chlorides on moving across period 3 of the periodic table is shown in Table. 1.3.

**Table 1.3 Melting Points of Chlorides of Period Three Elements and Their Bonding Character**

Name of compounds	Property	
	Melting point ( $^{\circ}\text{C}$ )	Type of bonding
NaCl	808	Ionic
$\text{MgCl}_2$	715	Partly ionic
$\text{AlCl}_3$	192	Partly ionic
$\text{SiCl}_4$	-68	Partly covalent
$\text{PCl}_3$	-93	Partly covalent
$\text{S}_2\text{Cl}_2$	-80	Partly covalent

As the intermolecular forces in covalent halide molecules are weak van der Waal's forces so they are often gases, liquids or low melting point solids. Physical properties of covalent halides are influenced by the size and polarizability of the halogen atom. Iodides, as being the largest and more polarizable ions, possess the strongest van der Waal's forces and therefore have higher melting and boiling points than those of other covalent halides.

The variation in bonding character is also present in descending from top to bottom in the halogen group. In general, for a metal the order of decreasing ionic character of the halides is: fluoride > chloride > bromide > iodide. For example,  $\text{AlF}_3$  is purely ionic compound having melting point  $1290^{\circ}\text{C}$  and fairly a good conductor, whereas,  $\text{AlI}_3$  is predominantly covalent with melting point  $198^{\circ}\text{C}$  and electrically a non-conductor. In case of an element forming more than one halides, the metal halide in its lower oxidation state tends to be ionic, while that in the higher oxidation state is covalent. For example,  $\text{PbCl}_2$  is mainly ionic and  $\text{PbCl}_4$  is fairly covalent. This can again be explained by the high polarizing power of  $\text{Pb}^{4+}$  as compared to that of  $\text{Pb}^{2+}$ .

### b) Hydrides

The binary compounds of hydrogen with other elements are called hydrides. According to the nature of bonding, hydrides may be broadly classified into three classes: ionic, covalent and intermediate. The elements of group IA and the heavier members of group IIA form ionic hydrides, which contain  $\text{H}^-$  (Hydride) ion. These hydrides are crystalline solid compounds, with high melting and boiling points and which conduct electricity in molten state. The tendency towards covalent character increases on moving from left to right in the Periodic Table. Hydrides of beryllium and magnesium represent the class of intermediate hydrides. Their properties are in between the ionic and covalent hydrides. They have polymeric structures and covalent nature, Table 1.4.

Table 1.4. Hydrides of the Elements of IA to VIIA and IIB Subgroups.

IA	IIA	IIB	IIIA	IVA	VA	VIA	VIIA
LiH	BeH <sub>2</sub>		BH <sub>3</sub>	CH <sub>4</sub>	NH <sub>3</sub>	H <sub>2</sub> O	HF
NaH	MgH <sub>2</sub>		AlH <sub>3</sub>	SiH <sub>4</sub>	PH <sub>3</sub>	H <sub>2</sub> S	HCl
KH	CaH <sub>2</sub>	ZnH <sub>2</sub>	GaH <sub>3</sub>	GeH <sub>4</sub>	AsH <sub>3</sub>	H <sub>2</sub> Se	HBr
RbH	SrH <sub>2</sub>	CdH <sub>2</sub>	InH <sub>3</sub>	SnH <sub>4</sub>	SbH <sub>3</sub>	H <sub>2</sub> Te	HI
CsH	BaH <sub>2</sub>			PbH <sub>4</sub>	BiH <sub>3</sub>		
	IONIC	INTERMEDIATE		COVALENT			

The covalent hydrides are usually gases or volatile liquids. They are non-conductors and dissolve in organic solvents. Their bond energies depend on the size and the electronegativity of the element. Stability of covalent hydrides increases from left to right in a period and decreases from top to bottom in a group. Fluorine forms the most stable hydride and the least stable are those of thallium, lead and bismuth. These hydrides are formed by elements with electronegativity values greater than 1.8 (Pauling Scale). Since the electronegativity of hydrogen is 2.1, most of these hydrides have polar

covalent bonds in which hydrogen is carrying a slight positive charge. On moving from left to right across a period the electronegativity of the other element increases and the hydrogen-element bond becomes more polar. Due to high polarity the hydrides like H<sub>2</sub>O and HF are capable of forming hydrogen bonds between their molecules. The boiling points of covalent hydrides generally increase on descending a group as shown in Table 1.5, except the hydrides like H<sub>2</sub>O, HF and NH<sub>3</sub> which,

Table 1.5. Melting and Boiling points of Hydrides of Groups IV A and VI A

Hydrides	Properties	
	Melting point (°C)	Boiling point (°C)
(Group IVA)		
CH <sub>4</sub>	-184	-164
SiH <sub>4</sub>	-185	-112
GeH <sub>4</sub>	-165	-90
SnH <sub>4</sub>	-150	-52
(Group VIA)		
H <sub>2</sub> O	0.00	100
H <sub>2</sub> S	-85.5	-60.3
H <sub>2</sub> Se	-65.7	-42
H <sub>2</sub> Te	-49	-2

due to hydrogen bonding, have higher boiling points than might be expected.

### c) Oxides

Oxygen forms compounds, called oxides, with almost every other element in the periodic table. Since, many of these have quite unusual properties, there is an extensive and varied chemistry of the compounds of oxygen. Oxides can be classified in more than one ways: based upon the type of bonding they have as well as their acidic or basic character. We shall discuss here the classification based on their acidic or basic behaviour. In this chapter, you have already studied that metal oxides are basic in character as they yield bases in water and

non-metallic oxides are acidic because they form acids in water. Basic oxides and acidic oxides react with one another to give salts, for example:



There is a third type of oxides, which show both acidic and basic properties, these oxides are called amphoteric oxides. The classification of elements which form oxides of acidic or basic and amphoteric properties is shown in Table 1.6.

**Table 1.6: Classification of Oxides Based on their Acid and Base Character**

IA	IIA	IIB	IIIA	IVA	VA	VIA	VIIA
Li	Be		B	C	N	O	F
Na	Mg		Al	Si	P	S	Cl
K	Ca	Zn	Ga	Ge	As	Se	Br
Rb	Sr	Cd	In	Sn	Sb	Te	I
Cs	Ba	Hg	Tl	Pb	Bi	Po	At
BASIC			AMPHOTERIC			ACIDIC	

The oxides of alkali and alkaline earth metals except beryllium are basic and contain  $\text{O}^{2-}$  ions. The  $\text{O}^{2-}$  ion has high affinity for proton and cannot exist alone in an aqueous solution. Therefore, it immediately takes proton from water and forms  $\text{OH}^-$  ion. Oxides of nonmetallic elements i.e. of C, N, P and S are acidic in nature. They generally dissolve in water to produce acidic solutions. Oxides of relatively less electropositive elements, such as  $\text{BeO}$ ,  $\text{Al}_2\text{O}_3$ ,  $\text{Bi}_2\text{O}_3$  and  $\text{ZnO}$  are amphoteric and behave as acids towards strong bases and as bases towards strong acids.

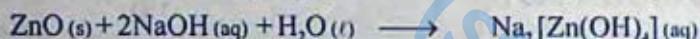

In a given period, the oxides change from strongly basic through weakly basic, amphoteric and weakly acidic to strongly acidic, e.g.  $\text{Na}_2\text{O}$ ,  $\text{MgO}$ ,  $\text{Al}_2\text{O}_3$ ,  $\text{P}_4\text{O}_{10}$ ,  $\text{SO}_3$ ,  $\text{Cl}_2\text{O}_7$ . The basic character of main group metal oxides increases on descending a group of the periodic table, (e.g.  $\text{BeO} < \text{MgO} < \text{CaO} < \text{SrO} < \text{BaO}$ ), though the reverse trend is observed in the transition metal oxides. The oxidation state of the metal also affects the acidic/basic character of its oxide. The acidic character increases with increasing oxidation state (e.g. the acidity of  $\text{MnO} < \text{Mn}_2\text{O}_3 < \text{MnO}_2 < \text{Mn}_2\text{O}_7$ ).

## 1.5 THE POSITION OF HYDROGEN

Although, it is not a metal but in most of the modern versions of periodic table, hydrogen is placed at the top of the group IA. This is because of the fact that some of the properties of hydrogen resemble with those of alkali metals. Like alkali metals hydrogen atom has one electron in  $1s$  subshell, which it can lose to form  $\text{H}^+$ . Both hydrogen and alkali metals have a strong tendency to combine with electronegative elements such as halogens. Similar to alkali

metals hydrogen also forms ionic compounds, which dissociate in water. However, hydrogen is also markedly different from alkali metals. For example, hydrogen is a non-metal in true sense. It does not lose electron as easily as most of the alkali metals do. Unlike alkali metals molecular hydrogen exists in nature.

Hydrogen resembles halogens in certain respects and can be placed at the top of VIIA group in the periodic table. Hydrogen is a gas like most of the halogens and is stable in diatomic form such as  $F_2$ ,  $Cl_2$  and  $Br_2$ . As required by halogens, hydrogen also needs one electron to complete its outermost shell. By accepting one electron hydrogen forms  $H^-$  (Hydride ion) similar to  $F^-$ ,  $Cl^-$  and  $Br^-$ . Both hydrogen and halogens form stable ionic compounds with alkali metals. However, hydrogen differs from halogens as well. By losing its only electron, hydrogen forms  $H^+$  but halogens do not form positive ions. Combining with oxygen, hydrogen forms very stable oxides while halogens lack this property.

Some of the characteristic properties of hydrogen also resemble with those of group IVA elements such as C and Si, etc. For example, valence shell of hydrogen is half filled like those of group IVA elements. Both, hydrogen and group IV elements combine with other elements through covalent bonding. Like carbon, hydrogen also possesses remarkable reducing properties.



Hydrogen also shows marked differences with carbon and rest of the group members. For example, carbon and silicon form long chain compounds, when their atoms combine with each other, while hydrogen does not form such compounds. Similarly, carbon can simultaneously form bonds with more than one elements, whereas hydrogen due to having only one electron can combine with only one element at a time.

Some of the properties of hydrogen are similar to those of the elements of certain groups, as discussed above, but it is a fact that hydrogen is a unique element whose properties do not match exactly with any of the groups in the periodic table. However, due to partial resemblance in properties with alkali metals and monovalent nature, hydrogen is usually placed at the top of elements in group IA.

## KEY POINTS

1. Although a number of chemists attempted to classify the elements but Dmitri Mendeleev gave the most useful and comprehensive classification.
2. In Mendeleev's periodic table the elements were arranged according to the ascending order of their atomic masses.
3. The modern periodic law states "if the elements are arranged in ascending order of their atomic numbers, their chemical properties repeat in a periodic manner."
4. In modern periodic table elements with similar properties are placed in eight vertical

- columns called groups. Each group is divided into two subgroups A and B. Normal or typical elements are placed in subgroup A and transition elements are placed in subgroup B.
5. The seven horizontal rows of the periodic table are called "periods".
  6. Metals of subgroups IA and IIA are called Alkali metals and Alkaline earth metals, respectively. Members of subgroup VIIA are called halogens.
  7. Due to their less reactivity the elements shown in subgroup VIII A are called noble gases.
  8. Elements of periodic table can also be classified into s-block, p-block, d-block and f-block elements depending upon the valence orbital which is in the process of completion.
  9. Elements of periodic table can also be divided into metals, non-metals and metalloids depending upon their properties.
  10. Atomic radii increase from top to bottom in a group and decrease along a period.
  11. Positive ions are always smaller than their parent atoms while the negative ions are usually larger than the atoms from which they are formed.
  12. Ionization energies increase along a period and decrease down the group.
  13. Electron affinities generally increase with increasing atomic number within a period and decrease from lighter to heavier elements in a given group.
  14. Metallic character of elements increases down the group and decreases along a period.
  15. The oxidation state of a typical element is directly or indirectly related to the group number to which the element belongs in the periodic table.
  16. The electrical conductance of an element depends upon the number of free or moveable electrons.
  17. There are three types of halides: ionic, polymeric and covalent. Halides of group IA are ionic in nature, have three dimensional lattices with high melting and boiling points.
  18. There are three types of hydrides formed by the elements of periodic table: ionic, intermediate and covalent.
  19. Highly polar hydrides show hydrogen bonding in them.
  20. Oxides may be divided on the basis of their acidic, basic or amphoteric character.
  21. Metallic oxides are basic in character, non-metallic oxides are acidic in character and oxides of less electropositive elements like Zn and Pb are amphoteric.
  22. Hydrogen is unique element of the periodic table. Due to similarities in properties it can be placed at the top of group IA or IVA or VIIA.

## EXERCISE

Q 1. Fill in the blanks.

- (i) Mendeleev in his periodic table, arranged the elements according to their atomic \_\_\_\_\_.
- (ii) Vertical columns in modern periodic table are called \_\_\_\_\_ and horizontal rows are called \_\_\_\_\_.
- (iii) Members of group VIIA are called \_\_\_\_\_ and alkali metals is the family name of \_\_\_\_\_ group members.
- (iv) Metals form \_\_\_\_\_ oxides and non-metals form \_\_\_\_\_ oxides.
- (v) Hydrogen can be placed above the groups \_\_\_\_\_ of the periodic table.
- (vi) Shielding effect is actually the \_\_\_\_\_ due to electrons in between the nucleus and the outermost shell.
- (vii) Noble gases have the \_\_\_\_\_ values of ionization energy due to their complete outermost shells.
- (viii) When a second electron is added to a uninegative ion, the incoming electron is \_\_\_\_\_ by the already present negative charge.
- (ix) Due to having partly filled d-orbitals \_\_\_\_\_ metals usually show variable valency.
- (x) Melting and boiling points of halogens \_\_\_\_\_ down the group.

Q 2. Indicate True or False.

- (i) In Mendeleev's periodic table elements Be, Mg, Zn and Cd are placed in the same group.
- (ii) The second and third periods contain eighteen elements each.
- (iii) Alkaline earth metals are present in Group IIA.
- (iv) Metals are present in the top right corner of the periodic table.
- (v) Metalloids are present in the lower half of Groups IVA, VA and VIA.
- (vi) Hydrogen forms uninegative ion like halogens.
- (vii) Oxidation state of an element is related to the number of period it belongs.
- (viii) Diamond is a good conductor of electricity.
- (ix) Melting points of halogens decrease down the group.
- (x) Zinc oxide is an example of amphoteric oxide.

3. Multiple choice questions. Encircle the correct answer.

- (i) Keeping in view the size of atoms, which order is the correct one?

a)  $Mg > Sr$    b)  $Ba > Mg$    c)  $Lu > Ce$    d)  $Cl > I$

- (ii) Mark the correct statement:

a)  $Na^+$  is smaller than Na atom   b)  $Na^+$  is larger than Na atom  
c)  $Cl^-$  is smaller than Cl atom   d)  $Cl^-$  (ion) and Cl (atom) are equal in size

- (iii) Mark the correct statement.
- All lanthanides are present in the same group.
  - All halogens are present in the same period.
  - All the alkali metals are present in the same group.
  - All the noble gases are present in the same period.
- (iv) Which statement is incorrect?
- All the metals are good conductor of electricity.
  - All the metals are good conductor of heat.
  - All the metals form positive ions.
  - All the metals form acidic oxides.
- (v) Which statement is correct?
- Hydrogen resembles in properties with IA, IVA and VIIA elements.
  - Hydrogen resembles in properties with IIIA, IVA and VA elements.
  - Hydrogen resembles in properties with IIA, IVA and VIA elements.
  - Hydrogen resembles in properties with IIA, IIIA and VIIA elements.
- (vi) Mark the correct statement:
- The ionization energy of calcium is lower than that of barium.
  - The ionization energy of calcium is lower than that of magnesium.
  - The ionization energy of calcium is higher than that of beryllium.
  - The ionization energy of calcium is lower than that of strontium.
- (vii) Mark the correct statement:
- Electron affinity is a measure of energy required to remove the electron.
  - Electron affinity is a measure of energy released by adding an electron.
  - Electron affinity is a measure of energy required to excite an electron.
  - Electron affinity is measure of energy released by removing an electron.
- (viii) Mark the correct statement.
- Metallic character increases down the group.
  - Metallic character increases from left to right along a period.
  - Metallic character remains the same from left to right along a period.
  - Metallic character remains the same down the group.
- (ix) Mark the correct statement:
- Melting points of halogen is decreased down the group.
  - Melting points of halogens increase down the group.
  - Melting points of halogens remain the same throughout the group.
  - Melting points of halogens first increase and then decrease down the group.

(x) Mark the correct statement:

- Covalent character of metal halides increases from left to right in a period.
- Boiling points of Group IVA hydrides decrease down the group.
- Ionic character of hydrides increases from left to right in a period.
- The basicity of group IIA oxides decreases on descending the group.

Q 4. What are the improvements made in the Mendeleev's periodic table?

Q 5. How the classification of elements in different blocks helps in understanding their chemistry?

Q 6. How do you justify the position of hydrogen at the top of various groups?

Q 7. Why the ionic radii of negative ions are larger than the size of their parent atoms?

Q 8. Why ionization energy decreases down the group and increases along a period?

Q 9. Why the second value of electron affinity of an element is usually shown with a positive sign?

Q 10. Why metallic character increases from top to bottom in a group of metals?

Q 11. Explain the variation in melting points along the short periods.

Q 12. Why the oxidation state of noble gases is usually zero?

Q 13. Why diamond is a non-conductor and graphite is fairly a good conductor?

Q 14. Give brief reason for the following.

- d and f-block elements are called transition elements.
- Lanthanide contraction controls the atomic sizes of elements of 6th and 7th periods.
- The melting and boiling points of the elements increase from left to the right upto the middle of s- and p-block elements and decrease onward.
- The oxidation states vary in a period but remain almost constant in a group.
- The hydration energies of the ions are in the following order:  
 $Al^{3+} > Mg^{2+} > Na^{+}$
- Ionic character of halides decreases from left to the right in a period.
- Alkali metals give ionic hydrides.
- Although both sodium and phosphorus are present in the same period of the periodic table yet their oxides are different in nature,  $Na_2O$  is basic while  $P_2O_5$  is acidic in character.

## CHAPTER

## 2

## s-BLOCK ELEMENTS

## IN THIS CHAPTER YOU WILL LEARN

1. To write the electronic configuration of s-block elements in sequence.
2. The occurrence of group IA and IIA elements and the peculiar behaviours of lithium and beryllium.
3. The difference in the physical properties of group IA and IIA elements as well as the differences in the chemical behaviour of their compounds.
4. The commercial preparation of sodium.
5. How sodium hydroxide is commercially prepared.
6. The role of gypsum and lime in agriculture and industry.

## 2.1 INTRODUCTION

The s-block elements are the metals in Group IA and Group IIA of the periodic table. They are called the s-block elements because s-orbitals are being filled, in their outermost shells.

The elements of group IA except hydrogen are called "Alkali metals" while those of IIA are named "Alkaline-earth metals".

The name alkali came from Arabic, which means 'The Ashes'. The Arabs used this term for these metals because they found that the ashes of plants were composed chiefly of sodium and potassium. Alkali metals include the elements, lithium, sodium, potassium, rubidium, cesium and francium. These are very reactive metals, produce strong alkaline solutions with water. The alkaline-earth metals are beryllium, magnesium, calcium, strontium, barium and radium. They are called alkaline-earth because they produce alkalis in water and are widely distributed in earth's crust.

The alkali and alkaline earth metals include the most reactive electropositive elements and a study of their electronic configurations will help in understanding their properties.

## 2.1.1 Electronic Configurations of s-Block Elements.

## Alkali Metal

Alkali metals have only one electron in 's' orbital of their valence shell. All alkali metals lose their one electron of the valence shell to form monovalent ions  $M^{+1}$  because their ionization energy values are very low. They form ionic compounds and show +1 oxidation state.

The electronic configurations and some physical constants of alkali metals are given in Table 2.1.

**Table 2.1 Electronic Configurations and Physical Constants of Alkali Metals**

Properties	Li	Na	K	Rb	Cs
Atomic number	3	11	19	37	55
Electronic configurations	$1s^2 2s^1$	$[\text{Ne}]3s^1$	$[\text{Ar}]4s^1$	$[\text{Kr}]5s^1$	$[\text{Xe}]6s^1$
Ionization energy (kJ/mol)	520	496	419	403	376
Electron affinity (kJ/mol)	60	53	48	45	47
Electronegativity	1.0	0.9	0.8	0.8	0.7
Atomic radius	152	186	227	248	265
Ionic radius of 1+ion (pm)	76	102	138	152	167
Melting points ( $^{\circ}\text{C}$ )	181.0	98	63	39.0	28.5
Boiling points ( $^{\circ}\text{C}$ )	1347	881	766	705	690
Density $\text{gm/cm}^3$ at ( $20^{\circ}\text{C}$ )	0.53	0.97	0.86	1.53	1.9
Heat of hydration (kJ/mol)	505	475	384	345	310

### Alkaline Earth Metals

Alkaline earth metals have two electrons in 's' orbital of their valence shell. All alkaline earth metals lose their two electrons to form divopositive ions  $\text{M}^{2+}$ , because their ionization energy values are low. They form ionic compounds and show +2 oxidation state. The electronic configurations and some physical constants of alkaline earth metals are given in Table 2.2.

**Table 2.2 Electronic Configurations and Physical Constants of Alkaline Earth Metals**

Properties	Be	Mg	Ca	Sr	Ba
Atomic number	4	12	20	38	56
Electronic configurations	$1s^2 2s^2$	$[\text{Ne}]3s^2$	$[\text{Ar}]4s^2$	$[\text{Kr}]5s^2$	$[\text{Xe}]6s^2$
Ionization energy (kJ/mol)	899	738	590	549	503
Electron affinity (kJ/mol)	240	230	156	168	52
Electronegativity	1.5	1.2	1.0	1.0	0.9
Atomic radius	112	197	215	222	198
Ionic radius of 2+ion (pm)	72	100	118	135	148
Melting points ( $^{\circ}\text{C}$ )	1287	649	839	768	727
Boiling points ( $^{\circ}\text{C}$ )	2500	1105	1381	1850	1700
Density $\text{gm/cm}^3$ at ( $20^{\circ}\text{C}$ )	1.85	1.74	1.55	2.63	36.2
Heat of hydration (kJ/mol)	2337	1897	1619	1455	1250

In going down a group the number of shells increases by one at each step and equal to the number of the period to which the element belongs.

### 2.1.2 Occurrence of Alkali Metals

Due to high reactivity, the alkali metals occur in nature in the combined state. None of the alkali metals is found free in nature. Sodium and potassium are abundant alkali metals and each constitutes about 2.4 percent of earth's crust. Most of the earth's crust is composed of insoluble aluminosilicates of alkali metals.

Lithium deposits, usually in the form of complex minerals, are widely scattered over the earth. An important commercial source of lithium is the mineral spodumene,  $\text{LiAl}(\text{SiO}_3)_2$ .

Small amounts of rubidium and caesium are found in potassium salts deposits. Francium has not been found in nature. It has been prepared artificially in the laboratory and is very unstable, thus a very little is known about this metal.

### 2.1.3 Occurrence of Alkaline Earth Metals

Being very reactive, alkaline earth metals also do not occur in free state. The compounds of these metals occur widely in nature.

Magnesium and calcium are very abundant in earth's crust. The outer portion of the earth was originally in the form of silicates and aluminosilicates of alkaline earth metals. Magnesium and calcium, with sodium and potassium are present in the rocks as cations.

Magnesium halides are found in sea water. Magnesium is an essential constituent of chlorophyll.

Calcium phosphate,  $\text{Ca}_3(\text{PO}_4)_2$ , and calcium fluoride,  $\text{CaF}_2$ , are also found as minerals. Calcium is an essential constituent of many living organisms. It occurs as skeletal material in bones, teeth, sea-shells and egg shells.

Table 2.3 Common Minerals of The Most Important Alkali Metals

Name of Mineral	Chemical Formula
<b>Lithium</b>	
Spodumene	$\text{LiAl}(\text{SiO}_3)_2$
<b>Sodium</b>	
Rock Salt (Halite)	$\text{NaCl}$
Chile saltpeter	$\text{NaNO}_3$
Natron	$\text{Na}_2\text{CO}_3 \cdot \text{H}_2\text{O}$
Trona	$\text{Na}_2\text{CO}_3 \cdot 2\text{NaHCO}_3 \cdot 2\text{H}_2\text{O}$
Borax	$\text{Na}_2\text{B}_4\text{O}_7 \cdot 10\text{H}_2\text{O}$
<b>Potassium</b>	
Carnallite	$\text{KCl} \cdot \text{MgCl}_2 \cdot 6\text{H}_2\text{O}$
Sylvite	$\text{KCl}$
Alunite (Alum Stone)	$\text{K}_2\text{SO}_4 \cdot \text{Al}_2(\text{SO}_4)_3 \cdot 4\text{Al}(\text{OH})_3$

Table 2.4 Common Minerals of the Alkaline-Earth Metals

Name of Mineral	Chemical Formula
<b>Beryllium</b>	
Beryl	$\text{Be}_3\text{Al}_2(\text{SiO}_3)_6$
Chrysoberyl	$\text{Al}_2\text{BeO}_4$
<b>Magnesium</b>	
Magnesite	$\text{MgCO}_3$
Dolomite	$\text{MgCO}_3 \cdot \text{CaCO}_3$
Carnallite	$\text{KCl} \cdot \text{MgCl}_2 \cdot 6\text{H}_2\text{O}$
Epsom salt	$\text{MgSO}_4 \cdot 7\text{H}_2\text{O}$
Soap stone (talc)	$\text{H}_2\text{Mg}_3(\text{SiO}_3)_4$
Asbestos	$\text{CaMg}_3(\text{SiO}_3)_4$
<b>Calcium</b>	
Calcite (Limestone)	$\text{CaCO}_3$
Gypsum	$\text{CaSO}_4 \cdot 2\text{H}_2\text{O}$
Fluorite	$\text{CaF}_2$
Phosphorite	$\text{Ca}_3(\text{PO}_4)_2$
<b>Strontium</b>	
Strontionite	$\text{SrCO}_3$
<b>Barium</b>	
Barite	$\text{BaSO}_4$

Radium is a rare element. It is of great interest because of its radioactive nature.

### 2.1.4 Peculiar Behaviour of Lithium

In many of its properties, lithium is quite different from the other alkali metals. This behavior is not unusual, because the first member of each main group of the periodic table shows marked deviation from the regular trends of the group as a whole.

The deviation shown by lithium can be explained on the basis of its small radius and high charge density. The nuclear charge of  $\text{Li}^+$  ion is screened only by a shell of two electrons. The so called 'anomalous' properties of lithium are due to the fact that lithium is unexpectedly far less electropositive than sodium.

Some of the more important differences of lithium from other alkali metals are listed below:

1. Lithium is much harder and lighter than the other alkali metals.
2. The lithium salts of anions with high charge density are generally less soluble in water than those of the other alkali metals, e.g.  $\text{LiOH}$ ,  $\text{LiF}$ ,  $\text{Li}_3\text{PO}_4$ ,  $\text{Li}_2\text{CO}_3$ .
3. Lithium forms stable complex compounds, although complex formation generally is not a property of alkali metals. One of the stable complexes formed by lithium is  $[\text{Li}(\text{NH}_3)_4]^+$
4. Lithium reacts very slowly with water, while other alkali metals react violently.
5. Lithium salts of large polarizable anions are less stable than those of other alkali metals. Unlike other alkali metals lithium does not form bicarbonate, tri-iodide or hydrogen sulphide at room temperature.
6. When burnt in air lithium forms only normal oxide, whereas the others form peroxides or superoxides.
7. Lithium hydride is more stable than the hydrides of other alkali metals.
8. Lithium compounds are more covalent, that is why its halides are more soluble in organic solvents and the alkyls and aryls of lithium are more stable than those of other alkali metals.
9. Lithium is the least reactive metal of all the alkali metals.
10. When acetylene is passed over strongly heated lithium, it does not produce lithium acetylide, but other alkali metals form the corresponding metallic acetylides.

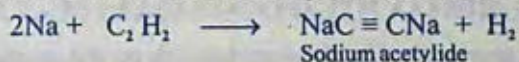

11. Lithium has low electropositive character, thus its carbonate and nitrate are not so stable and therefore decompose giving lithium oxide. Carbonates of other alkali metals do not decompose. Decomposition of lithium nitrate gives different products than the nitrates of other alkali metals.

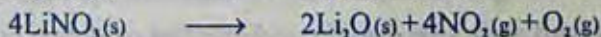
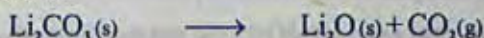

12. Lithium hydroxide when strongly heated, forms lithium oxide but the other alkali metal hydroxides do not show this behaviour.

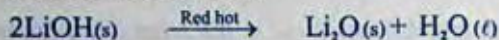

13. Lithium reacts with nitrogen to form nitride, while the other members of the group do not give this reaction.



14. Lithium chloride has an exothermic heat of solution, whereas chlorides of sodium and potassium have endothermic heats of solution.
15. Lithium carbide is the only alkali metal carbide formed readily by the direct reaction.

### 2.1.5 Peculiar Behaviour of Beryllium

Beryllium is the lightest member of the series and differs from the other group IIA elements in many ways. This is due to its small atomic size and comparatively high electronegativity value.

The main points of difference are:

1. Beryllium metal is almost as hard as iron and hard enough to scratch glass. The other alkaline earth metals are much softer than beryllium but still harder than the alkali metals.
2. The melting and boiling points of beryllium are higher than other alkaline earth metals. (Table 2.2).
3. As reducing agents, the group IIA metals are all powerful enough to reduce water, at least in principle. However, with water, beryllium forms insoluble oxide coating that protects it from further attack.
4. Beryllium in particular is quite resistant towards complete oxidation, even by acids, because of its BeO coating.
5. Beryllium is the only member of its group which reacts with alkalis to give hydrogen. The other members do not react with alkalis.

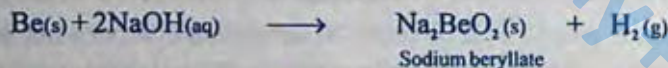

## 2.2 GENERAL BEHAVIOUR OF ALKALI METALS

The reducing property of an element depends on the magnitude of its ionization energy. Reducing agent is a substance which can lose electrons. Since alkali metals have got low ionization energies, so they are strong reducing agents. They are highly electropositive. They react readily with halogens giving alkali metal halides.

### 2.2.1 Trends in Chemical Properties of Alkali Metals

1. Low ionization energies make the alkali metals, the most reactive family of metals.
2. Very high second ionization energies indicate that oxidation number higher than +1, are ruled out for the alkali metals.

3. The cations of alkali metals have low charge and large radii than the radius of any cation from the same period, so the lattice energies of their salts are relatively low. Consequently, most of the simple salts of the alkali metals are water soluble. Most of the salts are dissociated completely in aqueous solution and the hydroxides are among the strongest bases available.
4. They react with oxygen and the surface is tarnished due to the oxides formed. Only lithium burns in air to form the normal oxide,  $\text{Li}_2\text{O}$  (white solid).



The exposed metals are oxidized almost immediately by oxygen in air, and in the presence of moisture. The oxides formed react with  $\text{CO}_2$  in the atmosphere to form carbonates.



Sodium will undergo a similar reaction, but only if the supply of oxygen is limited. In the presence of excess of oxygen, sodium forms the pale yellow peroxide.

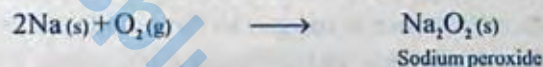

Potassium, rubidium and caesium react with oxygen to form superoxides (orange yellow). Caesium explodes spontaneously when it is in contact with air or oxygen.



5. Very rapid reactions occur when alkali metals react with water. A small piece of sodium (potassium or lithium) floated on water reacts vigorously to liberate hydrogen and produce metal hydroxide. The reaction is highly exothermic. The energy produced by the reaction may even ignite the hydrogen.



The reaction becomes increasingly vigorous from lithium to caesium. Potassium, rubidium and caesium are so highly reactive that they react with ice even at  $-100^\circ\text{C}$ .

6. Alkali metals form ionic hydrides with hydrogen.



Rubidium and caesium react violently with hydrogen at room temperature. The other three metals require elevated temperature in order to form the hydride. Lithium and sodium hydrides are useful sources of hydrogen when treated with water.



Due to the presence of hydride ion ( $\text{H}^-$ ), the ionic hydrides are used as powerful reducing agents.

7. Lithium is the only Group IA metal that combines with nitrogen and carbon to form nitride and carbide, respectively.

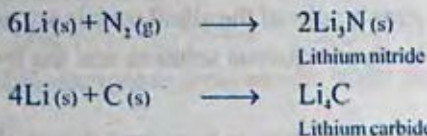

Alkali metals react easily with halogens to give halides. Lithium and sodium, for example, react slowly with chlorine at room temperature. Molten sodium burns with a brilliant yellow flame in a chlorine atmosphere to form sodium chloride.



Potassium, rubidium and caesium react vigorously with all the halogens, forming metal halides.

All alkali metals form their sulphides when treated with molten sulphur. The general reaction is:

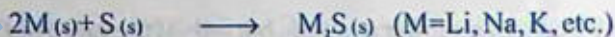

### 2.2.2 Trends in Chemical Properties of Alkaline Earth Metals

1. The alkaline earth metals burn in oxygen to form oxides or in the case of barium, the peroxide. Beryllium is the least reactive metal in the group. It is resistant to complete oxidation and stable in air at ordinary temperature but oxidizes rapidly at about  $800^\circ\text{C}$ . Therefore beryllium is not tarnished by atmospheric attack but the other metal soon loses the silvery appearance.



When exposed to air magnesium quickly becomes coated with the layer of  $\text{MgO}$ . This layer protects the surface from further corrosion at ordinary temperature.



When magnesium is burnt in air a small amount of nitride is also formed along with magnesium oxide:

When barium is heated in air or oxygen at  $500 - 600^\circ\text{C}$ , its peroxide is formed.

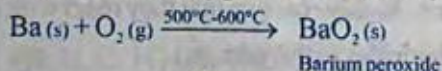

2. Hydrides are produced by treating the molten alkaline earth metals with hydrogen, usually under high pressures.

Magnesium reacts with hydrogen at high pressure and in the presence of a catalyst ( $\text{MgI}_2$ ) forming magnesium hydride.

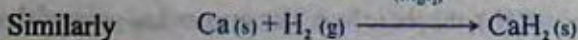
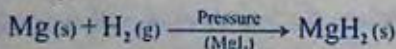

3. All Group II-A elements react with nitrogen on heating giving nitrides. For example,

magnesium reacts with nitrogen to give magnesium nitride.



The nitrides hydrolyse vigorously when treated with water, giving ammonia and the respective hydroxides.



4. With sulphur, magnesium gives magnesium sulphide, MgS. The other Group II-A metals also react similarly.



5. All group II-A elements react directly with halogens giving halides of the type  $\text{MX}_2$ , e.g.



6. Magnesium is more reactive than beryllium, even though it is not attacked by cold water. Magnesium reacts slowly with boiling water and quite rapidly with steam to liberate hydrogen.



Beryllium does not react with water even at red hot temperature but remaining alkaline earth metals produce hydroxides with water.



### 2.2.3 General Trends in Properties of Compounds of Alkali and Alkaline Earth metals

#### 1) Oxides

Alkali metal oxides dissolve in water to give strong alkaline solutions. For example:

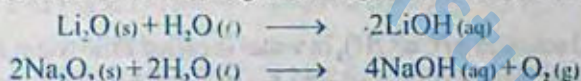

The reaction of an alkali metal oxide with water is an acid-base reaction and not an oxidation reduction reaction since no element undergoes a change in its oxidation number. The reaction simply involves the decomposition of water molecule by an oxide ion.



The basic character of alkali metal oxides increases down the group. Potassium superoxide ( $\text{KO}_2$ ) has a very interesting use in breathing equipments for mountaineers and in space craft. It has the ability to absorb carbon dioxide while giving out oxygen at the same time.



The solubility of alkaline-earth metal oxides in water increases down the group. BeO and MgO are insoluble but CaO, SrO and BaO are soluble and react with water to form the corresponding hydroxides.

The basic character of the oxides of alkaline earth metals increases down the group. The

tendency for group IIA oxides to form alkaline solution is relatively less than that of alkali metals.

Group I-A	Group II-A
Lithium oxide (Basic)	Beryllium oxide (Amphoteric)
Sodium oxide (Basic)	Beryllium oxide (Basic)
Potassium oxide (Basic)	Calcium oxide (Basic)

BeO is amphoteric in nature since it reacts with both acids and bases.



## ii) Hydroxides

The alkali metal hydroxides are all crystalline solids, very soluble in water except LiOH, which is slightly soluble. They are generally hygroscopic and are very strong bases, except LiOH.

The solubility of alkaline earth metal hydroxides in water increases down the group. Be(OH)<sub>2</sub> is quite insoluble. Mg(OH)<sub>2</sub> is sparingly soluble while Ba(OH)<sub>2</sub> is more soluble. This increase in solubility is due to low lattice energy of hydroxides which is, in turn, due to higher ionic size.

Alkali metal hydroxides are stable to heat except LiOH, while alkaline earth metal hydroxides like Mg(OH)<sub>2</sub> and Ca(OH)<sub>2</sub> decompose on heating.

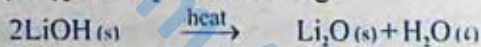

A saturated solution of Ca(OH)<sub>2</sub> in water is called lime water and is used as a test for CO<sub>2</sub>. A suspension of Mg(OH)<sub>2</sub> in water is called milk of magnesia and it is used for treatment of acidity in stomach.

## iii) Carbonates

The carbonates of alkali metals are all soluble in water and are stable towards heat except Li<sub>2</sub>CO<sub>3</sub>, which is not only insoluble but also decomposes on heating to lithium oxide. The decomposition is made easy because the electrostatic attraction in converting from carbonate to oxide is considerable. In case of large cation like K<sup>+</sup> in K<sub>2</sub>CO<sub>3</sub>, the gain in electrostatic attraction is relatively much less and the decomposition is difficult.

Sodium carbonate is very important industrial chemical. At temperature below 35.2°C, Na<sub>2</sub>CO<sub>3</sub> crystallizes out from water as Na<sub>2</sub>CO<sub>3</sub> · 10H<sub>2</sub>O, which is called washing soda. Above this temperature it crystallizes as Na<sub>2</sub>CO<sub>3</sub> · H<sub>2</sub>O. On standing in air, Na<sub>2</sub>CO<sub>3</sub> · 10H<sub>2</sub>O slowly loses water and converted to a white powder Na<sub>2</sub>CO<sub>3</sub> · H<sub>2</sub>O. The solution of Na<sub>2</sub>CO<sub>3</sub> in water is basic due to hydrolysis of carbonate ion.



Unlike the alkali metal carbonates, the alkaline earth metal carbonates are only very slightly soluble in water, with the solubility decreasing down the group. They also decompose on heating and the ease of decomposition decreases down the group.



The ease of decomposition can be related to the size of the metal ion, the smaller the ion, the more is the lattice energy of the resulting oxide and hence higher the stability of the product.

#### iv) Nitrates

Nitrates of both alkali and alkaline earth metals are soluble in water. Nitrates of Li, Mg, Ca and Ba decompose on heating to give  $\text{O}_2$ ,  $\text{NO}_2$  and the metallic oxide whereas nitrates of Na and K decompose to give different products.

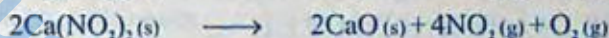
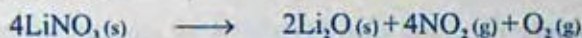

#### v) Sulphates

All the alkali metals give sulphates and they are all soluble in water. The solubilities of sulphates of alkaline earth metals, gradually decrease down the group.  $\text{BeSO}_4$  and  $\text{MgSO}_4$  are fairly soluble in water.  $\text{CaSO}_4$  is slightly soluble, while  $\text{SrSO}_4$  and  $\text{BaSO}_4$  are almost insoluble.

Calcium sulphate occurs in nature as gypsum  $\text{CaSO}_4 \cdot 2\text{H}_2\text{O}$ . When it is heated above  $100^\circ\text{C}$ , it loses three quarters of its water of crystallization, giving a white powder called 'Plaster of Paris'.

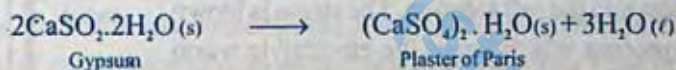

### 2.3 COMMERCIAL PREPARATION OF SODIUM BY DOWN'S CELL

Most of sodium metal is produced by the electrolysis of fused sodium chloride. Since the melting point of sodium chloride is  $801^\circ\text{C}$ , some calcium chloride is added to lower its melting point and to permit the furnace to operate at about  $600^\circ\text{C}$ .

In the electrolytic cell, the large block of graphite at the centre is the anode, above which there is a dome for the collection of chlorine. The cathode is a circular bar of copper or iron which surrounds the anode but is separated from it by an iron screen, which terminated in a gauze. The arrangement permits the electric current to pass

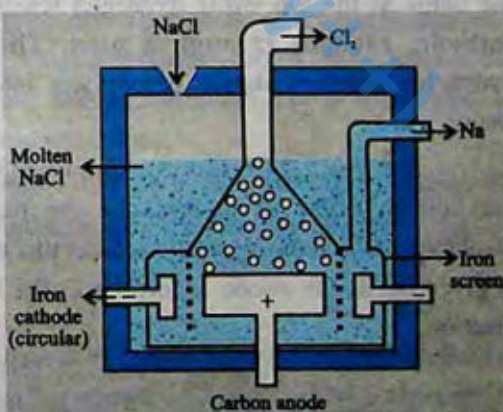

Fig.2.1 Down's Cell

freely but prevents sodium and chlorine from mixing after they have been set free at the electrodes, Fig. 2.1.

Sodium metal rises in a special compartment from which it is taken out at intervals. The cell produces dry chlorine and 99.9 percent pure sodium. The process is carried out at  $600^{\circ}\text{C}$  and it has the following advantages.

- The metallic fog is not produced.
- Liquid sodium can easily be collected at  $600^{\circ}\text{C}$ .
- Material of the cell is not attacked by the products formed during the electrolysis.

During the process the following reactions take place:

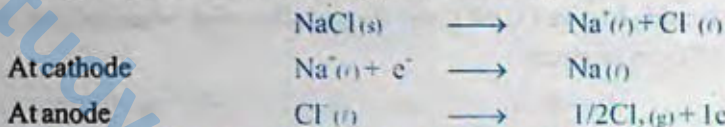

## 2.4 COMMERCIAL PREPARATION OF SODIUM HYDROXIDE BY THE DIAPHRAGM CELL

Sodium hydroxide is manufactured on a large scale by the electrolysis of aqueous solution of common salt in a diaphragm cell Fig. 2.2 (a). The cell is made of steel tank. An oblong perforated steel vessel lined inside with asbestos diaphragm serves as a cathode. It is provided with a constant level device to keep the vessel filled to the specified level with brine. A graphite anode is held within the U shaped diaphragm and it projects into the salt solution. The steam is blown during the process which keeps the electrolyte warm and helps to keep the perforations clear.

The chlorine released at the anode, rises into the dome at the top while hydrogen released at the cathode, escapes through a pipe. The sodium hydroxide solution slowly percolates into a catch basin.

The Fig. 2.2 (b) shows a simplified version of the cell in order to understand the purpose of diaphragm. When the electrolysis takes place, chlorine is given off at the anode according to the following reaction.



At the cathode hydrogen is discharged by the reduction of water.

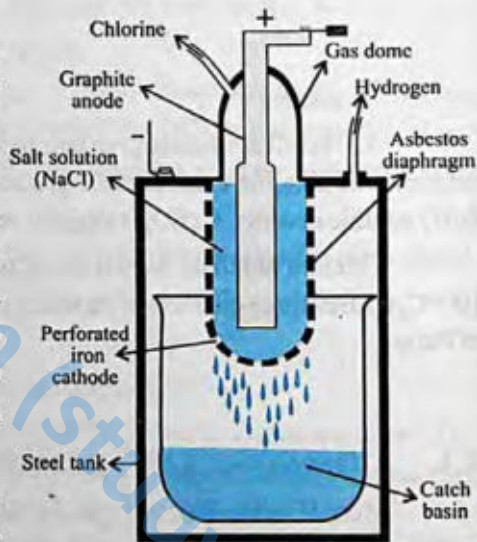

Fig.2.2(a) Nelson Cell for the Production of NaOH

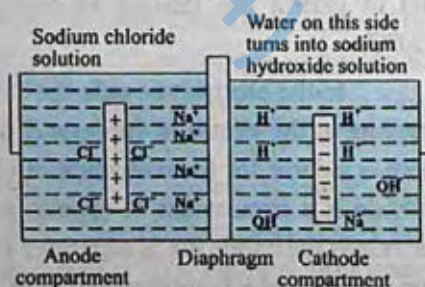

Fig.2.2(b)



The overall result of the above reactions is that the brine loses its chloride ions and the solution turns increasingly alkaline in cathode compartment.

We can face two major problems during the working of the cell.

1. Chlorine produced can react with hydroxide ions in cold giving hypochlorite ions.



2. Hydroxide ions may be attracted towards anode, where they can be discharged releasing oxygen gas. This oxygen gas may contaminate the chlorine and renders it impure.

The first problem is solved by using asbestos diaphragm. This keeps the two solutions separate while allowing sodium ions to move towards the cathode. This movement of ions keeps the current flowing through the external circuit.

The second problem is solved keeping the level of brine in anode compartment slightly higher, this keeps the direction of flow of liquid toward the cathode and thus preventing the possibility of hydroxides ions to reach the anode.

The solution that flows out of the cathode compartment contains 11% NaOH and 16% NaCl. Evaporation of this solution crystallizes the less soluble NaCl which is filtered off, the liquid left contains about 50% NaOH and only 1% NaCl as an impurity. For commercial purposes this small impurity is not important.

## 2.5 ROLE OF GYPSUM IN AGRICULTURE AND INDUSTRY

### (a) Role of Gypsum in Agriculture

Gypsum, a hydrated calcium sulphate, is a mineral that occurs in large deposits throughout the world.

Gypsum is applied to the soil as a source of calcium and sulphur. The calcium supplied by gypsum in fertilizers is of importance in crop production in areas where soils are subject to extensive leaching.

Sulphur has been recognised as an essential constituent of plants. For centuries, sulphur compounds had been applied to soils because of their observed beneficial effect on plant growth. Aside from serving as a constituent of protein and various other compounds in plants, sulphur has an influence on chlorophyll development in plant leaves. Although not a constituent of chlorophyll, plants deficient in sulphur exhibit a pale green colour.

The root system of several plants have been observed to be greatly enlarged by the application of sulphur. It has been reported that good crops are produced by the application of sulphur containing materials such as gypsum.

### (b) Role of Gypsum in Industries

When gypsum is heated under carefully controlled conditions, it loses three quarters of water of crystallization. The resulting product is called Plaster of Paris. Gypsum must not be heated too strongly as the anhydrous salt is then formed which absorbs water slowly. Such plaster

is called 'Dead burnt'.

Plaster of Paris when mixed with half of its weight of water forms a plastic type viscous mass and then sets to a hard porous mass. This process is completed within 10 to 15 minutes. During the process expansion about 1% in volume also occurs, which fills the moulds completely and thus a sharp impression is achieved.

Plaster of Paris is used for making plaster walls, casts of statuary, coins, etc.

It is used in surgery, Plaster of Paris bandages are used for holding in place fractured bones after they have been set.

Special plasters contain plaster of Paris and other ingredients which vary with the demands of the use to which they are to be put.

Two varieties of plasters are made.

(1) **Cement Plaster.**

It is plaster of Paris to which usually glue or other oils have been added as retarders to prolong the time of setting.

(2) **Hard Finish Plasters**

These are made by the calcination of the anhydrous sulphate with alum or borax. These plasters are set very slowly but give a hard finish.

When mixed with wood pulp and allowed to set in the form of boards, it forms a material, much used in the construction of buildings as wall boards and partitions. Gypsum is also used as a filler in paper industries.

Portland cement is made by strongly heating a finely powdered mixture of clay and limestone. The final product, known as clinker, is cooled and then ground into a very fine powder. During the grinding about 2% of gypsum is added which prevents the cement from hardening too rapidly. The addition of gypsum increases the setting time of cement.

## 2.6 ROLE OF LIME IN AGRICULTURE AND INDUSTRY

Lime, (CaO) is a soft, white compound which is obtained by the thermal decomposition of  $\text{CaCO}_3$ .

(a) **Role of Lime in Agriculture**

Large quantities of calcium oxide are used in agriculture for neutralizing acidic soils. It has been found that application of lime to acidic soils increases the amount of readily soluble phosphorus.

Calcium oxide is also used in large amounts for making lime-sulphur sprays which have a strong fungicidal action. The hydroxide of calcium is obtained when the oxide of the calcium is allowed to react with water. The process is called slaking of lime and it is an exothermic reaction.



### Functions of Calcium in Plant-Growth

The presence of calcium is essential for the normal development of plants. The quantity

of calcium required by different plants varies considerably. An adequate supply of calcium appears to stimulate the development of root hairs and, in fact, the entire root system.

Calcium is also necessary for normal leaf development and tends to accumulate in leaves as well as in bark. An adequate supply of calcium is also essential for the optimum activity of microorganisms that produce nitrates.

The effect of calcium on the supply of available phosphorus in the soil is of special significance. Soils containing sufficient calcium are slightly alkaline in nature.

When a deficiency of calcium exists various substances such as aluminium and manganese may accumulate in plants in harmful concentrations.

### (b) Role of Lime in Industries

1. Large quantities of lime are used in the extraction and refining of metals.
2. Lime is also used in paper, cement and leather industries.
3. The ability of lime to react with sand at high temperature forming calcium silicate ( $\text{CaSiO}_3$ ) serves as an important basis for glass manufacture.
4. Lime is used in ceramic industry for producing different types of sanitary materials.
5. Ordinary mortar, also called lime mortar, is prepared by mixing freshly prepared slaked lime (one volume) with sand (three or four volumes) and water to form a thick paste. This material when placed between the stones and bricks hardens or sets, thus binding the blocks firmly together. The equations for the chemical reactions which take place when mortar hardens are:

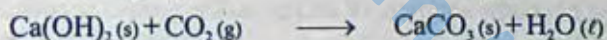

6. Lime is also used in refining of sugar and other food products.
7. Lime is used in the manufacturing of bleaching powder, which is used for the bleaching of the fabric and paper pulp.
8. A suspension of the calcium hydroxide is called milk of lime and is used as a whitewash.
9. When lime is heated with coke at about  $2800^\circ\text{C}$  in an electric furnace, calcium carbide is produced, which on hydrolysis yields acetylene ( $\text{C}_2\text{H}_2$ ).



Calcium carbide

10. Lime is often employed as a dehydrating agent, for example, in the preparation of absolute alcohol and the drying of ammonia gas. A mixture of sodium hydroxide and calcium hydroxide (soda lime) is often employed to remove both water and carbon dioxide from certain gases.

## KEY POINTS

1. The elements of group IA except hydrogen are called 'alkali metals' while those of group IIA are named as alkaline earth metals.
2. Alkali metals have only one electron in s-orbital of their valence shell. They lose one electron of the valence shell forming monovalent positive ions.
3. Alkaline earth metals have two electrons in s-orbital of their valence shell. They lose two electrons forming dipositive ions  $M^{2+}$ .
4. Spodumene, Chile saltpetre, trona, borax, carnallite, sylvite, alunite, halite, natron, are the common minerals of alkali metals.
5. Beryl, magnesite, dolomite, epsom salt, asbestos, calcite, gypsum, strontionite and barite are the important minerals of alkaline earth metals.
6. Lithium behaves different from the other alkali metals.
7. Lithium forms only normal oxide, whereas the others form higher oxides like peroxides and superoxides.
8. Beryllium is the only member of group II, which reacts with alkalis to give hydrogen. The other members do not react with alkalis.
9. Nitrates of lithium, magnesium and barium on heating give oxygen, nitrogen peroxide and the corresponding metallic oxides.
10. When gypsum is heated above  $100^{\circ}\text{C}$ , it loses three quarters of its water of crystallization, giving white powder of  $\text{CaSO}_4 \cdot 1/2\text{H}_2\text{O}$  which is called Plaster of Paris.
11. Sodium is prepared by the electrolysis of molten sodium chloride in Down's cell.
12. Calcium is necessary for development of leaves and it tends to accumulate in leaves and bark. An adequate quantity of calcium is essential for the optimum activity of microorganisms that produce nitrates.
13. Lime is used in paper and glass industries. It is also used for refining sugar and other food products.

## EXERCISE

- Q1. Fill in the blanks:
- (i) Alkali metals are \_\_\_\_\_ reactive than alkaline earth metals.
  - (ii) Alkali metals decompose water vigorously producing \_\_\_\_\_ and hydrogen.
  - (iii) When heated in a current of dry hydrogen, alkaline earth metals form white crystals of the type  $\text{MH}_2$ .
  - (iv) The beryllium oxide, like the oxide of aluminium is amphoteric, while the hydroxides of the other members of the group II-A are \_\_\_\_\_.
  - (v) The elements of the group I-A are termed as alkali metals, because their \_\_\_\_\_ are alkaline.
  - (vi) Spodumene is an ore of \_\_\_\_\_ metal.
  - (vii) Alkali metal nitrates on heating give the corresponding \_\_\_\_\_ and oxygen.

- (viii)  $\text{Na}_2\text{CO}_3 \cdot \text{H}_2\text{O}$  is the chemical formula of a mineral of sodium which is known as \_\_\_\_\_.
- (ix) Metallic bicarbonates are decomposed on heating into their carbonates, along with \_\_\_\_\_ and \_\_\_\_\_.
- (x) Metal nitrates other than the alkali metals on heating decompose into the corresponding metal \_\_\_\_\_ along with the evolution of nitrogen peroxide and oxygen.

Q2. Indicate True or False.

- (i) Group I-A elements are called alkali metals because their chlorides are alkaline in nature
- (ii) Alkali metals are very good conductors of electricity.
- (iii) The hydroxides of alkali metals and alkaline earth metals are soluble in water.
- (iv) Plaster of Paris is a hemihydrate.
- (v) Alkali metals have low melting and boiling points as compared to those of alkaline earth metals.
- (vi) Lithium carbonate is decomposed to its oxide, but the carbonates of the other alkali metals are stable towards heat.
- (vii) All alkali metal sulphates are insoluble in water.
- (viii) Lithium combines with nitrogen to form lithium nitride but other alkali metals do not react with nitrogen.
- (ix) Trona is a mineral of lithium.
- (x) Alkaline earth metals are stronger reducing agents than alkali metals.

Q3. Multiple choice questions. Encircle the correct answer.

- (i) Which one of the following does not belong to alkaline earth metals?  
 (a) Be (b) Ra (c) Ba (d) Rn
- (ii) The oxide of beryllium is:  
 (a) acidic (b) basic (c) amphoteric (d) none of these
- (iii) Which ion will have the maximum value of heat of hydration?  
 (a)  $\text{Na}^+$  (b)  $\text{Cs}^{3+}$  (c)  $\text{Ba}^{2+}$  (d)  $\text{Mg}^{2+}$
- (iv) Which one of the following is not an alkali metal?  
 (a) francium (b) caesium (c) rubidium (d) radium
- (v) Which of the following sulphates is not soluble in water?  
 (a) sodium sulphate (b) potassium sulphate  
 (c) zinc sulphate (d) barium sulphate
- (vi) The element caesium bears resemblance with  
 (a) Ca (b) Cr  
 (c) both of these metals (d) none of these metals
- (vii) Chile saltpetre has the chemical formula:  
 (a)  $\text{NaNO}_3$  (b)  $\text{KNO}_3$   
 (c)  $\text{Na}_2\text{B}_4\text{O}_7$  (d)  $\text{Na}_2\text{CO}_3 \cdot \text{H}_2\text{O}$
- (viii) The mineral  $(\text{CaSO}_4 \cdot 2\text{H}_2\text{O})$  has the general name:

- (a) gypsum (b) dolomite (c) calcite (d) epsom salt
- (ix) Down's cell is used to prepare:
- (a) sodium carbonate (b) sodium bicarbonate  
(c) sodium metal (d) sodium hydroxide
- (x) Which element is deposited at the cathode during the electrolysis of brine in diaphragm cell?
- (a)  $H_2$  (b) Na (c)  $Cl_2$  (d)  $O_2$
- Q4. (a) Give the names, electronic configurations and occurrence of s-block elements.  
(b) Discuss the peculiar behaviour of lithium with respect to the other members of alkali metals.
- Q5. Discuss the trends in chemical properties of compounds like oxides, hydroxides, carbonates, nitrates and sulphates of IA and IIA group elements.
- Q6. Compare the chemical behaviour of lithium with magnesium.
- Q7. (a) Mention the properties of beryllium in which it does not resemble with its own family.  
(b) Why is the aqueous solution of  $Na_2CO_3$  alkaline in nature?
- Q8. (a) Describe with diagram the manufacture of sodium by Down's cell.  
(b) Point out the three advantages of this process.
- Q9. (a) Compare the physical and chemical properties of alkali metals with those of alkaline earth metals.  
(b) What happens when:  
(i) Lithium carbonate is heated.  
(ii) Lithium hydroxide is heated to red hot.  
(iii) Beryllium is treated with sodium hydroxide.  
(iv) Lithium hydride is treated with water.
- Q10. Give formulas of the following minerals.  
(a) Dolomite (b) Asbestos (c) Halite (d) Natron  
(e) Beryl (f) Sylvite (g) Phosphorite (h) Chile saltpetre
- Q.11. Answer the following questions briefly.
- (a) Why are alkali and alkaline earth metals among the reactive elements of the periodic table?
- (b) Why does lime water turn milky with  $CO_2$  but becomes clear with excess  $CO_2$ ?
- c) How is gypsum converted into plaster of Paris?
- (a) Why is 2% gypsum added in the cement?
- (e) Why is lime added to an acidic soil?
- (f) How are lime and sand used to make glass?
- (g) How is lime mortar prepared?

## CHAPTER

## 3

# GROUP IIIA AND GROUP IVA ELEMENTS

## In this chapter you will learn

1. The names, electronic configurations and occurrence of IIIA and IVA group elements.
2. The peculiar properties of boron and carbon in their respective groups.
3. The preparation and properties of borax and orthoboric acid.
4. The reactions of aluminium.
5. Structures and properties of oxides of carbon and silicon, silicates, silicones and their uses.
6. The uses of silicon and germanium in semi-conductor industries and lead in paints.

### 3.1 GROUP IIIA ELEMENTS

The Group IIIA of the Periodic Table comprises the elements boron, aluminium, gallium, indium and thallium.

Electronic configurations and some physical properties of group IIIA elements are shown in Table 3.1.

The small size and high nuclear charge make boron non-metallic while all the other elements of this group are metals. The abrupt increase in metallic character from B to Al is associated with the increased size of aluminium atom. The increase in the atomic size is not regular in this group. This is due to the presence of d electrons in heavier members which have poor shielding effect than s and p electrons.

**Table 3.1 Electronic Configurations and Physical Properties of Group IIIA Elements**

Properties	B	Al	Ga	In	Tl
Atomic number	5	13	31	49	81
Electronic configuration	[He]2s <sup>2</sup> 2p <sup>1</sup>	[Ne]3s <sup>2</sup> 3p <sup>1</sup>	[Ar]3d <sup>10</sup> 4s <sup>2</sup> 4p <sup>1</sup>	[Kr]4d <sup>10</sup> 5s <sup>2</sup> 5p <sup>1</sup>	[Xe]4f <sup>14</sup> 5d <sup>10</sup> 6s <sup>2</sup> 6p <sup>1</sup>

Properties	B	Al	Ga	In	Tl
Ionization energy (kJ/mol)	800	577	579	558	589
Electron affinity (kJ/mol)	-27	-45	-29	-29	-30
Electronegativity	2.0	1.5	1.6	1.7	1.8
Atomic radius (pm)	85	14.3	135	167	170
Ionic radius of 3+ion (pm)	20	54	62	80	150
Melting points (°C)	2180	660	30	157	304
Boiling points (°C)	3650	2467	2403	2080	1457
Density (g/cm <sup>3</sup> )	2.35	2.70	5.90	7.31	11.85

### 3.1.1 Occurrence (Boron and Aluminium)

Boron is not an abundant element.

It occurs in traces in most soils and has been found to be essential in very small amounts for the proper growth of many plants.

Boron is always found in nature combined with oxygen, usually as oxyborate ions. Boron occurs principally as salts of various polyboric acids.

Aluminium is the third most abundant element in the earth's crust (after oxygen and silicon).

It occurs primarily as alumino-silicate minerals found in the rocks of the outer portion of the earth.

The other elements of group IIIA gallium, indium and thallium are relatively rare and are obtained as by-products during the processing of other metals.

Table 3.2 Common Minerals of Boron

Name of Minerals of Boron	Chemical Formula
Borax or Tincal	Na <sub>2</sub> B <sub>4</sub> O <sub>7</sub> ·10H <sub>2</sub> O
Colemanite	Ca <sub>2</sub> B <sub>6</sub> O <sub>11</sub> ·5H <sub>2</sub> O
Orthoboric Acid	H <sub>3</sub> BO <sub>3</sub>

Table 3.3 Common Minerals of Aluminium

Name of Minerals of Aluminium	Chemical Formula
Feldspar	KAISi <sub>3</sub> O <sub>8</sub> or K <sub>2</sub> O·Al <sub>2</sub> O <sub>3</sub> ·6SiO <sub>2</sub>
Mica (Muscovite)	KH <sub>2</sub> Al <sub>2</sub> (SiO <sub>3</sub> ) <sub>2</sub>
Kaolin (Clay)	H <sub>2</sub> Al <sub>2</sub> (SiO <sub>3</sub> ) <sub>2</sub> ·H <sub>2</sub> O or Al <sub>2</sub> O <sub>3</sub> ·2SiO <sub>2</sub> ·2H <sub>2</sub> O
Corundum	Al <sub>2</sub> O <sub>3</sub>
Emerald	AlF <sub>2</sub> SiO <sub>4</sub>
Gibbsite	(Al <sub>2</sub> O <sub>3</sub> ·3H <sub>2</sub> O or Al(OH) <sub>3</sub> )
Bauxite	Al <sub>2</sub> O <sub>3</sub> ·2H <sub>2</sub> O
Cryolite	Na <sub>3</sub> AlF <sub>6</sub>
Diaspore	Al <sub>2</sub> O <sub>3</sub> ·H <sub>2</sub> O or AlO(OH)

### 3.1.2 Peculiar Behaviour of Boron

Boron is the first member of the Group IIIA, it shows many dissimilarities with the members of its own group. The difference in the properties of boron and those of the other members of the series is mainly due to the large difference in their sizes and ionization energies.

1. Boron is the only element in Group IIIA which is non-metallic in behaviour.
2. It is the only element with less than four electrons in the outermost shell which is not a

metal.

- Boron always uses all the three of its valence electrons for bonding purposes and its common oxidation states are +3 and -3.
- One of the outstanding features of the chemistry of boron is its ability to form molecular addition compounds.
- Boron does not form ionic compounds with sulphate, nitrate or other anions because boron does not form a stable cation.

## 3.2 COMPOUNDS OF BORON

### 3.2.1 Borax (Sodium Tetraborate $\text{Na}_2\text{B}_4\text{O}_7 \cdot 10\text{H}_2\text{O}$ )

Borax is the sodium salt of tetraboric acid. It is the most important of all borates.

#### Occurrence:

Borax occurs as a natural deposit called tincal in the dried up lakes of Tibet and California.

#### Manufacture:

- Formally borax was manufactured by treating a hot solution of boric acid with the proper amount of soda ash.

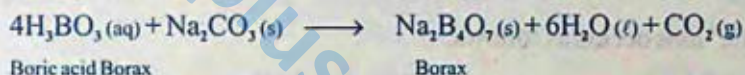

- Nowadays borax is almost exclusively obtained from calcium borate. Finely powdered colemanite is boiled with  $\text{Na}_2\text{CO}_3$  solution, when  $\text{CaCO}_3$  precipitates out and a mixture of borax and sodium metaborate is formed.



The clear solution from the top is taken off and is then allowed to crystallize, when crystals of borax separate out. To get more borax,  $\text{CO}_2$  is blown through the mother liquor, the sodium metaborate is decomposed into borax, which separates out in the form of fine crystals.

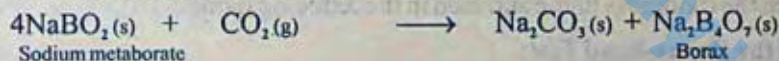

- Borax may also be obtained from tincal ( $\text{Na}_2\text{B}_4\text{O}_7 \cdot 10\text{H}_2\text{O}$ ) by treating tincal with water and subsequently evaporating the clear solution, when crystals of borax separate out.

#### Properties:

- Borax is a white, crystalline solid. It is sparingly soluble in cold water but is more soluble in hot water: 100 grams of water dissolve 3 grams of decahydrate at  $10^\circ\text{C}$  and 99.3 grams at  $100^\circ\text{C}$ . If a saturated solution be allowed to crystallize above  $62^\circ\text{C}$ , octahedral crystals of the pentahydrate,  $\text{Na}_2\text{B}_4\text{O}_7 \cdot 5\text{H}_2\text{O}$  separate out, if the temperature is below  $62^\circ\text{C}$ , the decahydrate is formed. Its aqueous solution is alkaline in nature due to hydrolysis.



The hydrolysis is prevented in the presence of glycerine.

2. When heated, borax loses water and swells up into a white porous mass due to the expulsion of water: on further heating it melts into a clear transparent glass, which dissolves many metallic oxides forming coloured beads. This reaction forms the basis of borax bead test.

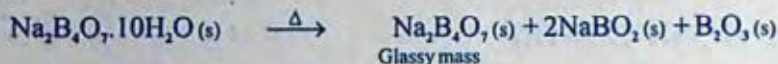

3. Its aqueous solution reacts with HCl or  $\text{H}_2\text{SO}_4$  to form boric acid:

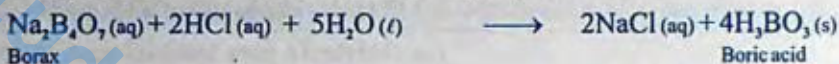

4. When borax is heated with ammonium chloride, boron nitride is produced:

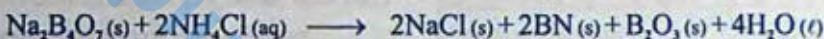

5. Borax when dissolved in water ionizes as:



Hydrolysis of  $\text{B}_4\text{O}_7^{2-}$  ions occurs as follows:



So, a strong alkali (NaOH) is formed which is highly ionized. On the other hand, boric acid ( $\text{H}_3\text{BO}_3$ ) is ionized to a little extent, because it is a weak acid. Hence, solution of borax as a whole is alkaline in nature.

### 6. Borax Bead Test

Prepare a loop at the end of a platinum wire. Heat the wire and take a little powdered borax on the hot loop. Heat again, borax first swells up and then melts into colourless, glass like bead on the loop. Now put a few grains of the substance, under examination, on the beads and re-heat it first in the oxidizing flame and then in the reducing flame.

#### Chemistry of the Borax-bead Test:

Borax, when fused, is decomposed into sodium metaborate and boric anhydride.



The metallic oxide formed from the substance, under examination, combines with  $\text{B}_2\text{O}_3$ , giving the coloured metallic borates. With cupric oxide, the beads are coloured blue in the oxidizing flame because cupric borates are blue in colour.



#### Uses of Borax:

1. It is used to prepare borate glass, which is heat resistant.
2. It is used in softening of water.

3. It is employed in borax bead test, for the detection of metallic cations.
4. It is used in metallurgical operations.
5. It is used as a flux in welding and in metallurgy.
6. It is employed in making washing powders.
7. It is used in leather industry for tanning and dyeing.
8. It is used in cosmetics, soaps, textiles, paints, medicine, match industry and as a preservative.

### 3.2.2 Boric Acids

There are four important boric acids. Out of these orthoboric acid is the most important and the stable one. The remaining acids are stable in solid state and change into orthoboric acid in solution:

- (i) Orthoboric Acid,  $H_3BO_3$ ,
- (ii) Metaboric Acid,  $HBO_2$ ,
- (iii) Tetraboric Acid,  $H_2B_4O_7$ ,
- (iv) Pyroboric Acid,  $H_6B_6O_{11}$ ,

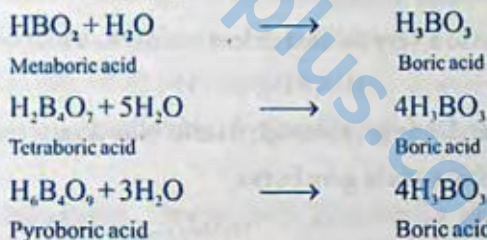

#### Orthoboric Acid or Boric acid ( $H_3BO_3$ )

It is a white crystalline chemical substance (triclinic), sparingly soluble in cold water (2.6% at  $40^\circ C$ ) but dissolves readily in hot water (37% at  $107^\circ C$ ). This temperature variation in solubility forms the basis for its separation and purification.

#### Preparation of Boric acid on Commercial Scale

##### 1. From Colemanite

On commercial scale, boric acid is prepared from a natural calcium borate called colemanite ( $Ca_2B_6O_{11} \cdot 5H_2O$ ) by suspending it in boiling water while, sulphur dioxide is passed through it. Boric acid crystallizes out from the solution while, the other product  $CaSO_3$  remains in the solution.

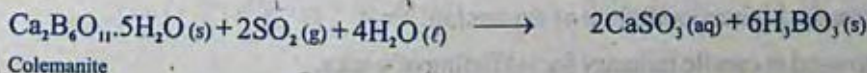

##### 2. From Borax

A hot concentrated solution of borax is treated with a calculated quantity of conc.  $H_2SO_4$ . On cooling, crystals of boric acid formed separate out.



### Properties of Boric Acid

1. Boric acid is a white lustrous crystalline solid having a soft soapy touch, very slightly soluble in cold water but fairly soluble in hot.
2. It is volatile in steam.
3. It reacts with ethyl alcohol forming ethyl borate.  

$$\text{H}_3\text{BO}_3(s) + 3\text{C}_2\text{H}_5\text{OH}(l) \longrightarrow (\text{C}_2\text{H}_5)_3\text{BO}_3(l) + 3\text{H}_2\text{O}(l)$$
4. When heated strongly, it swells to frothy mass losing water molecules. It is first converted into metaboric acid, then to tetraboric acid and finally to boric anhydride.



Metaboric Acid

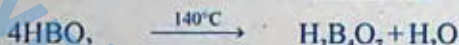

Tetraboric acid

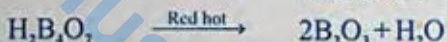

Boric anhydride

5. It is a very weak acid and ionizes to a very limited extent mainly as a monobasic acid.



6. Its solution has no effect on methyl orange, although it turns blue litmus red.
7. It is partially neutralised by caustic soda to give borax.



8. When boric acid is neutralized by soda ash ( $\text{Na}_2\text{CO}_3$ ), borax is obtained.



Borax

9. Boric acid being a weak acid, cannot be titrated with alkalis in the usual manner. In the presence of glycerol, however, it can be titrated against a standard alkali using phenolphthalein as an indicator.

### Uses of Boric Acid

1. Boric acid is used in medicines as an antiseptic, e.g. dusting powder, boric ointment and boric solution is used as an eyewash.
2. It is used in pottery as a glaze because borate glazes are more fusible than silicate glazes and possess a higher coefficient of expansion.
3. It is also used in candle industry for stiffening of wicks.

## 3.3 REACTIONS OF ALUMINIUM

### 1. Reaction with Air

When a piece of aluminium sheet is exposed to moist air it acquires a thin, continuous

coating of aluminium oxide, which prevents further attack on the metal by atmospheric oxygen and water under normal conditions. Because of this aluminium sheets are said to be corrosion free. However, if the aluminium powder is heated to 800°C and above, the metal will react with air to form aluminium oxide,  $Al_2O_3$ , and aluminium nitride,  $AlN$ . The reaction is accompanied by the evolution of heat and intense white light. This property of aluminium is made use of in flash light photography.



Because of its ability to combine with both oxygen and nitrogen, the metal is often used to remove air bubbles from molten metals. Salt solutions corrode aluminium badly so aluminium and aluminium alloys are not suitable for marine use.

## 2. Reaction with Non-Metals

Heated aluminium combines with the halogens, sulphur, nitrogen, phosphorus and carbon, accompanied by the evolution of heat.



Aluminium on heating with hydrogen forms aluminium hydride.



## 3. Reaction with Acids and Alkalies

Aluminium is amphoteric. It dissolves in both acids and bases with the liberation of hydrogen gas.

Aluminium reacts slowly with dilute acid and more rapidly with concentrated hydrochloric acid to displace hydrogen



Aluminium does not react with dilute sulphuric acid. However, it is oxidized by hot concentrated sulphuric acid to liberate sulphur dioxide gas.



Aluminium does not react with nitric acid at any concentration, probably because of the formation of protective layer of aluminium oxide. The acid is said to render the aluminium passive. Nitric acid is, therefore, frequently transported in aluminium containers.

Aluminium dissolves in both sodium and potassium hydroxides to form a soluble aluminate, with the evolution of hydrogen.



## USES

- Aluminium is very light (nearly three times less dense than iron) but possesses high tensile strength. These properties account for its extensive use in the transport industries, in the construction of aircrafts, ships and cars.

- It is an excellent conductor of both electricity and heat. Thus, it is used as heat exchanger in chemical, oil and other industries. Heavy duty electrical cables are made of aluminium metal.
- Aluminium is an excellent reflector of radiant energy. For this reason, it is commonly used to insulate buildings. Aluminium foil is also used to jam radar.
- It is non-magnetic and is thus used in navigational equipment.
- It is a good reducing agent and can thus be used for this purpose in the chemical and steel industries.
- It is non-toxic and can be used for making food and brewing equipments and in packaging.
- Aluminium readily forms alloys with other metals like copper, magnesium, nickel and zinc.
- At homes, aluminium is found in the form of cooking utensils, window frames and kitchen foil.
- Aluminium is used for making petrol and milk storage tanks because it reflects heat and prevents them of being over heated in the sun.

### 3.4 GROUPIVA ELEMENTS

Group IVA of the periodic table comprises elements, carbon, silicon, germanium, tin and lead.

There is a marked change of properties from carbon to lead. This gradation is of such nature, however, that there are very few similarities between the extreme members. Thus carbon and lead differ very considerably; far more, for example, than do lithium and caesium in group IA. The electronic configurations of IVA group elements along with their physical properties are given in Table 3.4.

Table 3.4 Electronic Configurations and Physical Properties of Group IVA Elements

Properties	C	Si	Ge	Sn	Pb
Atomic number	6	14	32	50	82
Electronic configuration	[He]2s <sup>2</sup> 2p <sup>2</sup>	[Ne]3s <sup>2</sup> 3p <sup>2</sup>	[Ar]3d <sup>10</sup> 4s <sup>2</sup> 4p <sup>2</sup>	[Kr]4d <sup>10</sup> 5s <sup>2</sup> 5p <sup>2</sup>	[Xe]4f <sup>14</sup> 5d <sup>10</sup> 6s <sup>2</sup> 6p <sup>2</sup>
Ionization energy (kJ/mol)	1086	786	761	708	715
Electron affinity (kJ/mol)	-122.5	-120	-116	-121	-101
Electronegativity	2.5	1.8	1.8	1.8	1.9
Atomic radius (pm)	77	118	122	140	146
Ionic radius of 2+ion (pm)	60	71	73	118	119
Melting points (°C)	3280	1420	945	232	327
Boiling points (°C) sublimes	4100	3280	2850	2623	1750
Density gm/cm <sup>3</sup> at (20°C)	2.27	2.34	5.32	7.26	11.34

Carbon and silicon are the only non-metals in Group IVA. Carbon has the peculiar property of forming long carbon chains, silicon forms long chains of alternating silicon and oxygen atoms.

1. Carbon and silicon both form acidic oxides, whereas the oxides of germanium, tin and lead are amphoteric in nature.
2. Both carbon and silicon form covalent bonds. Their oxides are acidic and both form hydrides and chlorides.

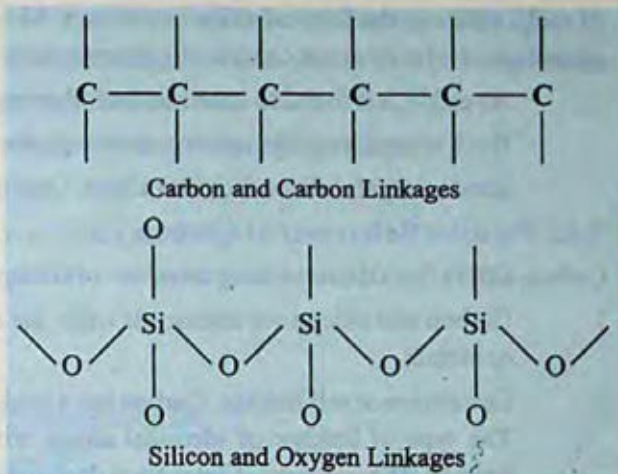

The elements of group IVA are characterized by a set of four valence electrons, which form two pairs.

In the first three elements of IVA group, carbon, silicon and germanium, all the four outermost electrons are used as valency electrons, while in tin and lead either all four (stannic and plumbic compounds) or only one of the pairs of electrons (stannous and plumbous compound) is used for bonding.

The pair of valence electrons that do not readily take part in chemical combination is termed as inert pair. As in other groups, the inert pair effect is most marked in the element of highest atomic mass, namely lead. The increase in electropositive character from carbon through silicon, tin, and lead is pronounced. This trend is shown also by the increase in the metallic character of the elements with increased atomic mass.

#### The Following are the Common Properties of Group IVA Elements:

1. All the elements of this group show a valency of four.
2. All of them form hydrides,  $MH_4$ .
3. They form tetrachlorides,  $MCl_4$ .
4. They also form the dioxides,  $MO_2$ .

#### 3.4.1 Occurrence of Carbon

Carbon occurs naturally in two states. One is crystalline (graphite, diamond) form and the other is amorphous (coal, charcoal) form.

#### 3.4.2 Occurrence of Silicon

Silicon is very abundant, about 25% of the mass of the Earth's crust being due to this element.

Silicon, unlike carbon, is not found in free state. Silicon is found as a major constituent

Minerals of Silicon	Chemical Formula
Analcite (a zeolite)	$NaAl(SiO_3)_2 \cdot H_2O$
Asbestos	$CaMg_3(SiO_3)_4$
Kaolin (pottery clay)	$H_2Al_2(SiO_4)_2 \cdot H_2O$
Zircon	$ZrSiO_4$
Talc (or soapstone)	$H_2Mg_3(SiO_3)_4$

of rocks either in the form of silica or silicates. Most minerals other than sulphides, sulphates, phosphates and carbonates contain a high proportion of silicon.

As oxide, it is found as quartz in the following forms:

Rock crystal, amethyst quartz, smoky quartz, rose quartz and milky quartz.

Sand is largely silicon dioxide (silica). Opal is a hydrated variety of quartz.

### 3.4.3 Peculiar Behaviour of Carbon

Carbon differs from the remaining members of Group IV-A in the following respects:

1. Carbon and silicon are nonmetals while the other members of the family are metalloids or metals.
2. Catenation or self linkage. Carbon has a tendency to form long chains of identical atoms. The type of linkage of identical atoms with each other is called catenation or self-linkage. The property of catenation decreases on moving down the group from carbon to lead. The maximum tendency of catenation associate with carbon forms the basis of the carbon compounds which constitute organic chemistry.

## 3.5 COMPOUNDS OF CARBON AND SILICON

### 3.5.1 Structure of Oxides of Carbon

Three oxides of carbon are known:

- (i) Carbon monoxide, CO
- (ii) Carbon dioxide, CO<sub>2</sub>
- (iii) Carbon suboxide, C<sub>3</sub>O<sub>2</sub>

Out of these, the last one is of little importance.

#### Structure of Carbon Monoxide (CO)

Carbon monoxide is diatomic molecule having triple bond between the two atoms. It is very slightly polar. The electronic structure of carbon monoxide can be represented as:  $:\text{C}:::\text{O}:$

It is usually written as:  $:\text{C}\equiv\text{O}:$

It might appear from the above structure that the molecule should have a large dipole moment, but in fact the molecule has a small dipole moment (0.112D).

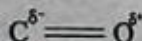

#### Structure of the Carbon Dioxide

Carbon dioxide exists in the gaseous state as linear molecules. The observed C–O bond distance is 115 pm and is in agreement with the structure shown. Solid CO<sub>2</sub> has a face-centered cubic structure. Being linear its dipole moment is zero.

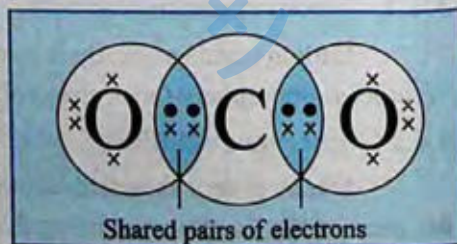

### 3.5.2 Oxides of Silicon

#### Silicon Dioxide

Silicon dioxide, SiO<sub>2</sub>, called silica, is probably the most common and the most important

compound of silicon. In silica every silicon atom is attached tetrahedrally to four oxygen atoms and each oxygen atom has two close silicon neighbours.

Vitreous silica possesses the following interesting and useful properties.

1. High transparency to light.
2. Very refractory, does not soften below 1500 to 1600°C.
3. Very low thermal expansion.
4. Excellent insulator.
5. Hard, brittle and elastic.
6. Insoluble in water and inert towards many reagents.
7. It is resistant towards all acids except HF.

**Quartz**, the common crystalline form of silicon dioxide, is a hard, brittle, refractor, colourless solid which differs very markedly from carbon dioxide.

Both carbon and silicon have four electrons in their valence shells and both also form four covalent bonds. So, why should there be a big difference between  $\text{CO}_2$  and  $\text{SiO}_2$ ?

The answer lies in the fact that silicon atoms are much larger than carbon atoms and thus tend to surround themselves with more oxygen neighbours; silicon forms only single bonds with oxygen atoms whereas carbon may form double bonds. Carbon, in fact, forms double bonds with each of the two oxygen atoms to produce a small, symmetrical, linear molecule  $\text{CO}_2$ , which is volatile and reasonably reactive.

The silicon atom can be approached closely by four oxygen atoms and forms a single bond with each at tetrahedral angles. This structure can be continued in three dimensions to produce a continuous giant silicon oxygen network extending out to give the massive silicon dioxide crystal.

In the interior of the silica network every silicon atom is bonded tetrahedrally with four oxygen atoms and every oxygen atom is bonded to two silicon atoms. The overall ratio of silicon to oxygen atoms is 1 : 2 and the simplest formula for silica therefore is  $\text{SiO}_2$ . The silicon oxygen bonds are strong and keep the atoms firmly in place.

Note, however, that it is not the molecular formula for silica but the whole chunk of silica must be considered to be essentially one molecule. The atoms of silicon and oxygen at the surface of the chunk do not

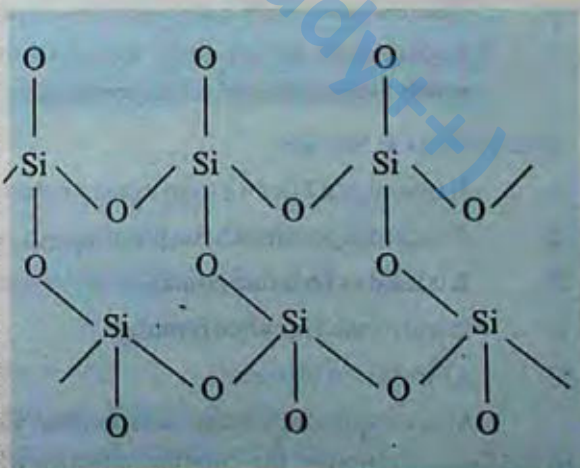

Fig. 3.1 Structure of Silicon dioxide

have all their valence forces satisfied, as is shown by the high surface activity of silica.

In each of the various crystalline forms of silica, there is a special pattern which is repeated throughout the crystal in a regular definite crystal lattice. The regular tetrahedral arrangement of four oxygen atoms around each silicon persists in each crystalline form but the Si-O-Si bond angles and the rotation about each Si-O bond are different in the different polymorphic species.

When crystalline silica is heated sufficiently it melts to give a viscous liquid having a random structure, presumably with the silicon atoms still on the average close to four oxygen atoms and the oxygen atoms close to two silicon atoms. When this liquid silica is cooled it does not crystallize readily, but usually it under supercools tremendously and eventually becomes rigid without having undergone orientation into a regular crystal pattern. This rigid, highly under supercooled liquid is called vitreous silica or silica glass (frequently incorrectly referred to as fused quartz).

### 3.5.3 Silicates and their Uses

The compounds derived from silicic acids are termed as silicates.

#### 1. Sodium silicate, $\text{Na}_2\text{SiO}_3$

This is a sodium salt of metasilicic acid  $\text{H}_2\text{SiO}_3$ . It is known as water glass or soluble glass. It is prepared by fusing sodium carbonate with pure sand. The process is carried out in a furnace called reverberatory furnace.



#### Properties:

Sodium silicate is soluble in water and its solution is strongly alkaline due to the hydrolysis.

#### Chemical Garden

When crystals of soluble coloured salts like nickel chloride, ferrous sulphate, copper sulphate or cobalt nitrate, etc. are placed in a solution of sodium silicate, they produce a very beautiful growth, like plant, which is called chemical garden.

#### Uses of Sodium Silicate:

1. It is used as a filler for soap in soap industry.
2. It is used in textile as a fire proof agents.
3. It is used as furniture polish.
4. It is also used in calico printing.

#### 2. Aluminium Silicate

Many important silicate rocks contain aluminium. The weathering of these rocks results in the disintegration of the complex silicates which they contain. The boiling and freezing of

water in the rocks, and the chemical action of water and carbon dioxide convert these compounds into potassium carbonate, sand and clay. The following reaction explains the weathering of potassium feldspar.



Pure clay, which has the formula shown above, is white and is called kaolin. It is used to make porcelain and china wares. Ordinary clay contains compounds of iron and other metals and it has a yellow or reddish yellow colour.

Impure clays can be more easily fused because they contain oxides of iron, calcium, magnesium and other metals which form easily fusible silicates with sand. Such clays are used to make bricks, tiles, and stonewares. Due to the presence of ferric oxide, the articles of this clay turn reddish when heated in a kiln.

Stoneware is usually glazed to give it a less porous surface by throwing salt (NaCl) upon the articles while they are hot. This treatment produces sodium aluminate and sodium aluminium silicate, which melt readily and cover the entire surface. When the article cools, the covering solidifies, producing a compact, smooth, waterproof surface. China wares are made from a mixture of kaolin, bone ash, and feldspar; the mixture fuses when heated and fills the pores between the grains of kaolin.

The use of clay in making pottery and other ceramic articles depends upon the plasticity of the paste. When soaked in water the clay progressively hydrates, and the paste becomes more plastic. When the clay is heated the water of hydration is lost, and a hard rock like mass is formed.

### 3. Talc or Soapstone

The magnesium silicate,  $Mg_3H_2(SiO_3)_4$ , is commonly known as talc or soapstone. It is physically greasy to touch. Therefore it is used in making cosmetics. It is also used in making household articles.

### 4. Asbestos

Asbestos is hydrated calcium magnesium silicate  $CaMg_3(SiO_3)_4$ . It is commonly used in making incombustible fabrics and hardboard, etc.

#### 3.5.4 Silicones

The chemistry of silicon is, in many respects, very much like the chemistry of carbon. Just as carbon forms the compounds carbon dioxide ( $CO_2$ ), carbon tetrachloride ( $CCl_4$ ), and methane ( $CH_4$ ), similarly silicon forms silicon dioxide ( $SiO_2$ ), silicon tetrachloride ( $SiCl_4$ ), and silane ( $SiH_4$ ).

The silicon atom holds four methyl groups,  $Si(CH_3)_4$ , just as the carbon atom,  $C(CH_3)_4$ . If a compound of silicon containing chlorine atoms and methyl groups,  $SiCl_4(CH_3)_2$ , is allowed to react with water, hydrogen chloride (HCl) comes out, and the silicon atoms join together through oxygen atoms.

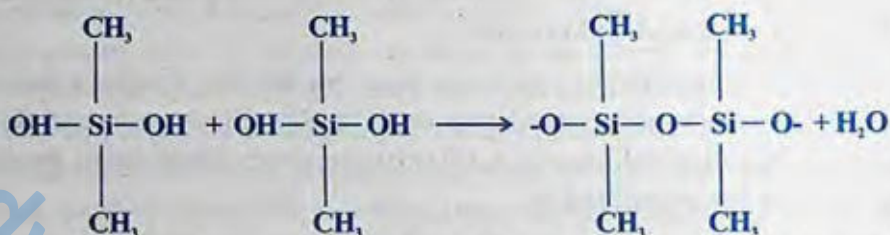
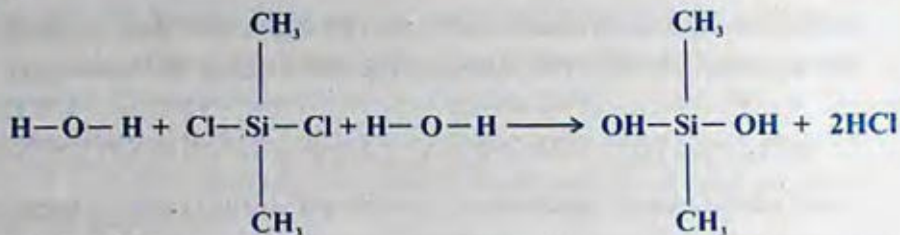

By this reaction we can make synthetically the silicon oxygen chains found in the mineral silicates, which we have just been discussing. A difference is that here we have  $-\text{CH}_3$  groups instead of oxygen atoms joined to silicon as side chains. Such a compound is called a silicone; this particular one is a methyl silicone. Other alkyl groups may also be substituted for the methyl groups and the molecular chain can be made of various lengths.

### Properties and Uses of the Silicones

Some of the methyl silicones are oily liquids and they become more viscous as the chain length increases. They are used as lubricants, either incorporated in greases or as oils, in bearings, gears, etc. They are also used in hydraulic brakes and other hydraulic systems. The outstanding physical attribute of silicone oil is its very small change in viscosity with change in temperature, compared with the behaviour of other oils of similar viscosity.

If the temperature is dropped from  $100^\circ\text{C}$  to  $0^\circ\text{C}$  the viscosity of petroleum oil may increase about one hundred folds, whereas that of silicone oil will increase less than four folds. In the presence of air or oxygen at temperature as high as  $300^\circ\text{C}$ , silicone oils remain free from acid formation, oxidation and similar phenomena, which frequently limit the usefulness of petroleum products and other synthetic organic liquids.

Methyl silicones of high molecular mass resemble rubber and are used in making rubber like tubing and sheets.

Silicone molecules can be made in such a way that bridges, or cross linkages bind one long molecule to another at several points along the chain. These compounds have resinous properties and are extensively used in electrical insulation.

Another interesting and important application of silicones is their use in the treatment of various surfaces to make them water repellent. A silicone film covers the surface and repels water like a grease film. Much of the leak of electricity through the moisture film on ceramic electrical insulators can be prevented by a silicone film; cloth, plastics, asbestos, glass, leather, and paper, even filter paper and blotting paper become strongly water repellent when covered with a

silicone film.

### 3.6 SEMICONDUCTORS

A semiconductor is a substance that has different resistances to the passages of an electric current under different circumstances. Semiconductors include the elements germanium, selenium and silicon, and the compounds lead sulphide, silicon carbide, cadmium sulphide, lead telluride, gallium arsenide and indium antimonide.

Semiconductors conduct electricity better than insulators, but not as well as good conductors like metals. This gives them their name, which means "half conductors." How well they conduct electricity depends upon their temperature. When a metal is heated, its resistance increases, when a semiconductor is heated its resistance decreases.

Semiconductors are also sensitive to light. The greater the intensity of the light that shines on them, the better they conduct electricity. The effects that light and heat energy have on semiconductors make them extremely useful. They are used in photoelectric cells and in solar batteries. The electrons of semiconductors do not carry electric current as readily as the electrons of good electric conductors like metals. However, when the atoms of the material absorb heat or light, the electrons become less tightly bound to their atoms. They can now conduct electricity.

Another special property of semiconductors is the way they behave when they are joined to another material, which may be a metal or a different semiconductor. The junction between the different materials forms a boundary. It allows electricity to pass more properly and is used in transistors. Transistors are much smaller and less complicated than old fashioned electronic tubes. They are used in radio, television, computers and calculators.

### 3.7 USES OF LEAD COMPOUNDS IN PAINTS

Various oxides of lead, basic lead carbonate and lead chromate are commonly used as pigments in paints.

#### 1. Lead Suboxide, $Pb_2O$

It is black powder, obtained on heating plumbous oxalate in the absence of air.

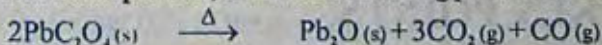

$Pb_2O$  is decomposed by heat into Pb and PbO.

Other than pigment, it is also used in the manufacture of lead storage batteries.

#### 2. Lead Monoxide (Litharge, Massicot) $PbO$

Litharge varies in colour from pale yellow to reddish yellow, possibly owing to the

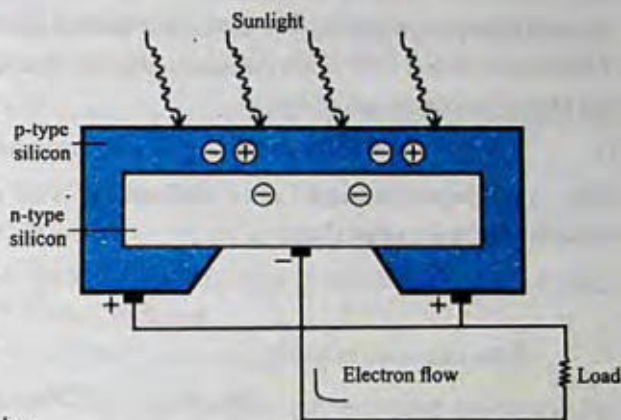
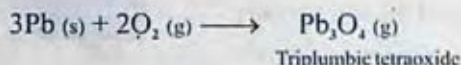

Fig. 3.2 A photovoltaic (solar) cell using silicon-based semiconductors

existence of two forms, a rhombic (yellow) and a tetragonal (red). It is slightly soluble in water. It is usually used in preparing flint glass and paints. Litharge is used in preparing oils and varnishes. If litharge is boiled with water and olive oil, lead oleate which is a sticky adhesive mass is formed and glycerine passes into solution.

### 3. Triplumbic Tetraoxide, (red lead, minium), $Pb_3O_4$

When lead is heated in air at about  $340^\circ\text{C}$ , it absorbs oxygen and forms a bright scarlet crystalline powder of red lead.



It decomposes at  $470^\circ\text{C}$ .



Red lead is used for a variety of purposes. Its principal uses are in the manufacture of storage batteries, as a pigment in paints applied to steel and iron to retard corrosion, and as an ingredient in the manufacture of flint glass, matches and ceramic glazes.

### 4. Lead Dioxide, $PbO_2$

When red lead is treated with concentrated nitric acid, it is decomposed into lead nitrate and lead dioxide.



Lead dioxide is a reddish brown powder. It is not very soluble in water, but it does dissolve in alkaline water to yield soluble plumbates. It is not affected by dilute acids.

### 5. White Lead

Basic lead carbonate  $2\text{PbCO}_3 \cdot \text{Pb(OH)}_2$  is an amorphous white pigment. It mixes readily with linseed oil and has a good covering power. If improperly prepared, it becomes crystalline and its covering power is reduced.

White lead is not suitable for use as a good pigment since it is darkened by the hydrogen sulphide which is frequently present in the atmosphere.

### 6. Lead Chromate ( $PbCrO_4$ )

It is used as a pigment under the name of chrome yellow. Orange or red basic lead chromates are formed when lead chromate is boiled with dilute alkali hydroxide and are used as pigments. The stable yellow modification of lead chromate is monoclinic. Mixture of lead chromate with lead sulphate or barium sulphate are also used as yellow pigments.

## KEY POINTS

1. Boron occurs in traces and has been found to be important for the growth of many plants.
2. Borax ( $\text{Na}_2\text{B}_4\text{O}_7 \cdot 10\text{H}_2\text{O}$ ), colemanite ( $\text{Ca}_2\text{B}_6\text{O}_{11} \cdot 5\text{H}_2\text{O}$ ), orthoboric acid ( $\text{H}_3\text{BO}_3$ ) are the common minerals of boron.
3. Aluminium, after oxygen and silicon, is the third most abundant element in the earth's

crust. Feldspar ( $K_2O \cdot Al_2O_3 \cdot 6SiO_2$ ), corundum ( $Al_2O_3$ ), bauxite ( $Al_2O_3 \cdot 2H_2O$ ) and cryolite ( $Na_3AlF_6$ ) are the common minerals of aluminium.

4. The pair of outermost electrons that does not readily take part in chemical combination is termed as inert pair.
5. When heated, borax fuses, loses water of crystallization and swells up into a white porous mass. It is employed in borax bead test for identification of coloured salts.
6. When a hot concentrated solution of borax is treated with a calculated quantity of conc.  $H_2SO_4$ , on cooling crystals of boric acid are produced.
7. When aluminium is burnt in oxygen a brilliant light is produced.
8. The electronic configuration of group IVA elements shows that they have four electrons in their valence shells, two of which are in s-orbital and the remaining two are in p-orbitals.
9. Feldspar, potash mica and zircon are the famous minerals of silicon.
10. Silica has a net work structure in which every silicon atom is bonded tetrahedrally to four oxygen atoms and every oxygen atom is bonded to two silicon atoms.
11. Sodium silicate, aluminium silicate, talc and asbestos are commercially important compounds of silicon and oxygen called silicates.
12. Methyl silicones can be used as lubricants and for water proofing.
13. Semiconductors conduct electricity better than insulators. They are also light sensitive.
14. Oxides of lead are used as pigments.

### EXERCISE

- Q.1. Fill in the blanks.
- i) \_\_\_\_\_ acid has the chemical formula  $HBO_2$ .
  - ii) Aluminium normally occurs as \_\_\_\_\_ minerals found in the rocks of outer portion of the earth.
  - iii) Aluminium gives \_\_\_\_\_ gas with hot concentrated  $H_2SO_4$ .
  - iv) Boron forms \_\_\_\_\_ bond in its compounds.
  - v) The chemical formula of white lead is \_\_\_\_\_.
  - vi) \_\_\_\_\_ is the only element with less than four electrons in the outer most shell that is not a metal.
  - vii) In the Group IIIA of the periodic table \_\_\_\_\_ is a semi-metal.
  - viii) Borax that occurs as a natural deposit, is called \_\_\_\_\_.
  - ix) Cryolite is an important mineral of aluminium and its formula is \_\_\_\_\_.
  - x) A \_\_\_\_\_ is a substance that has different resistances to the passage of an electric current under different circumstances.

- Q.2. Indicate True Or False
- Boron always uses all the three of its valence electrons for bonding purposes.
  - Diaspore is an ore of carbon.
  - Emerald is an ore of aluminium that has the chemical formula  $\text{Al}_2\text{O}_3 \cdot 2\text{SiO}_2 \cdot 2\text{H}_2\text{O}$ .
  - An aqueous solution of borax is feebly acidic in nature.
  - In case of borax bead test, of cupric oxide, the beads are coloured blue in the reducing flame.
  - Boric acid can be titrated with sodium hydroxide.
  - Carbon and silicon are the only non-metals in Group IVA.
  - $\text{PbO}$  is commonly known as litharge.
  - Basic lead carbonate is a reddish brown pigment.
  - Aluminium oxide ( $\text{Al}_2\text{O}_3$ ) is also called bauxite.
- Q3. Multiple choice questions. Encircle the correct answer.
- Which metal is used in the thermite process because of its reactivity:
    - Iron
    - Copper
    - Aluminium
    - Zinc
  - Aluminium oxide is:
    - acidic oxide
    - basic oxide
    - amphoteric oxide
    - none of these
  - Chemical composition of colemanite is:
    - $\text{Ca}_2\text{B}_6\text{O}_{11} \cdot 5\text{H}_2\text{O}$
    - $\text{CaB}_4\text{O}_7 \cdot 4\text{H}_2\text{O}$
    - $\text{Na}_2\text{B}_4\text{O}_7 \cdot 4\text{H}_2\text{O}$
    - $\text{CaNaB}_5\text{O}_{10} \cdot 8\text{H}_2\text{O}$
  - Which element forms an ion with charge +3:
    - Beryllium
    - Aluminium
    - Carbon
    - Silicon
  - Which electronic configuration corresponds to an element of Group-III A of the periodic table:
    - $1s^2, 2s^2, 2p^6, 3s^2, 3p^1$
    - $1s^2, 2s^2, 2p^6, 3s^2, 3p^4, 4s^2$
    - $1s^2, 2s^2, 2p^6$
    - $1s^2, 2s^2, 2p^6, 3s^2, 3p^3$
  - Which element belongs to Group IVA of the periodic table?
    - Barium
    - Iodine
    - Lead
    - Oxygen
  - Boric acid cannot be used:
    - as antiseptic in medicine
    - for washing eyes
    - in soda bottles
    - for enamels and glazes
  - Which of the following elements is not present abundantly in earth's crust?
    - Silicon
    - Aluminium
    - Sodium
    - Oxygen
  - Tincal is a mineral of:
    - Al
    - B
    - Si
    - C

- x) The chief ore of aluminium is:  
(a)  $\text{Na}_3\text{AlF}_6$  (b)  $\text{Al}_2\text{O}_3 \cdot 2\text{H}_2\text{O}$  (c)  $\text{Al}_2\text{O}_3$  (d)  $\text{Al}_2\text{O}_3 \cdot \text{H}_2\text{O}$
- Q. 4. What is the action of an aqueous solution of borax on litmus?
- Q. 5. Give equations to represent the following reactions.  
(a) Borax is heated with  $\text{CaO}$ . (b)  $\text{Al}_2\text{O}_3$  is heated with  $\text{NaOH}$  solution.
- Q. 6. Why is aluminium not found as a free element? Explain the chemistry of borax bead test.
- Q. 7. How does orthoboric acid react with:  
(a) Sodium hydroxide (b) Ethyl alcohol
- Q. 8. How will you convert boric acid into borax and vice versa?
- Q. 9. Why are liquid silicones preferred over ordinary organic lubricants?
- Q. 10. Explain:  
(a)  $\text{CO}_2$  is non-polar in nature. (b)  $\text{CO}_2$  is acidic in character.
- Q. 11. Why is  $\text{CO}_2$  a gas at room temperature while  $\text{SiO}_2$  is a solid?
- Q. 12. Give the names and the formulas of different acids of boron.
- Q. 13. What is the importance of oxides of lead in paints?
- Q. 14. Give the names, electronic configurations and occurrence of Group-III A elements of the periodic table.
- Q. 15. Discuss the peculiar behaviour of boron with respect to the other members of Group- III A elements.
- Q. 16. (a) What is borax?  
(b) Describe its commercial preparation.  
(c) Outline the principal uses of borax.  
(d) How does borax serve as a water softening agent?
- Q. 17. (a) What is boric acid?  
(b) How is boric acid prepared in laboratory?  
(c) Give properties and uses of boric acid.
- Q. 18. (a) Give the names alongwith the formulas of three important ores of aluminium.  
(b) How and under what conditions does aluminium react with the following:  
i) Oxygen ii) Hydrogen iii) Halogens iv) Acids v) Alkalies
- Q. 19. Give the names, electronic configurations and occurrence of Group-IV A elements of the periodic table.
- Q. 20. Discuss the peculiar behaviour of carbon with respect to the other members of Group-IV A of the periodic table.
- Q. 21. (a) What are silicones?  
(b) Give a brief summary of the principal properties of silicones.  
(c) Outline the uses of silicones.  
(d) What are silicates?  
(e) Describe the important uses of silicates.

## CHAPTER

## 4

# GROUP VA AND GROUP VIA ELEMENTS

## In this chapter you will learn

1. The names, electronic configuration and general characteristics of group VA and VIA elements.
2. The preparation and properties of oxides and oxyacids of nitrogen, phosphorus and halides of phosphorus.
3. Comparison of properties of oxygen and sulphur.
4. The manufacture, properties and uses of sulphuric acid.

## GROUP VA ELEMENTS

### 4.1 INTRODUCTION

The elements of group VA of the periodic table comprise nitrogen, phosphorus, arsenic, antimony and bismuth.

Table 4.1 Electronic Configurations and Physical Properties of Group VA Elements

Properties	N	P	As	Sb	Bi
Atomic number	7	15	33	51	83
Electronic configuration	[He]2s <sup>2</sup> 2p <sup>3</sup>	[Ne]3s <sup>2</sup> 3p <sup>3</sup>	[Ar]3d <sup>10</sup> 4s <sup>2</sup> 4p <sup>3</sup>	[Kr]4d <sup>10</sup> 5s <sup>2</sup> 5p <sup>3</sup>	[Xe]5d <sup>10</sup> 6s <sup>2</sup> 6p <sup>3</sup>
Physical appearance	Colourless gas	Black solid	Metallic solid	Metallic solid	Metallic solid
Ionization energy (kJ/mol)	1402	1012	947	834	703
Electron affinity (kJ/mol)	-7	-71.7	-77	-101	-110
Electronegativity	3.0	2.1	2.0	1.9	1.9
Atomic radius(pm)	75	110	120	140	150
Ionic radius of 3 <sup>-</sup> ion (pm)	146	212	222	245	---
Melting points (°C)	-210	44.1	816	631	271
Boiling points (°C)	-196	280	615	1587	1564
Density (g/cm <sup>3</sup> )	0.00125	1.82	5.78	6.70	9.8
Principal oxidation states	+3, +5	+3, +5	+3, +5	+3, +5	+3, +5

### 4.1.1 General Characteristics

Nitrogen and phosphorus of group VA show the typical properties of non-metals. For example, they are poor conductors of heat and electricity and give acidic oxides. Their compounds are predominantly covalent. Arsenic and antimony are metalloids. However bismuth at the bottom of the group shows definite metallic properties. The metallic character increases going down the group. Nitrogen has the greatest tendency to attract the electrons, antimony and bismuth have the least. The trend down the group also shifts from covalent bonding to ionic bonding. Phosphorus, arsenic and antimony have allotropes. Allotropes of phosphorus, i.e., red and white phosphorus are more important.

Phosphorus and other members of the group can make use of d orbitals in their bonding. This is because the energy of these orbitals is not much greater than those of the other valence shell orbitals. For example, phosphorus can make use of its 3s, 3p and the empty 3d orbitals during bonding with other elements.

In phosphorus one of the 3s electrons can be promoted to a vacant 3d orbital giving 5 unpaired electrons in the valence shell. Phosphorus can thus make three or five covalent bonds. Indeed three and five are the common valencies of the group VA elements.

## 4.2 NITROGEN AND ITS COMPOUNDS

### 4.2.1 Occurrence

Nitrogen is present in free state in air as a major constituent (78% by volume). It is an inactive gas in comparison with oxygen which is the next major constituent of air. Inorganic compounds of nitrogen are not commonly found as minerals.

In combined state nitrogen is found in all living matter including, animals and plants in the form of proteins, urea and amino acids.

### 4.2.2 Oxides of Nitrogen

Nitrogen forms several oxides with oxygen. Common oxides of nitrogen are  $N_2O$ ,  $NO$  and  $NO_2$ . It also forms  $N_2O_3$  and  $N_2O_5$ .

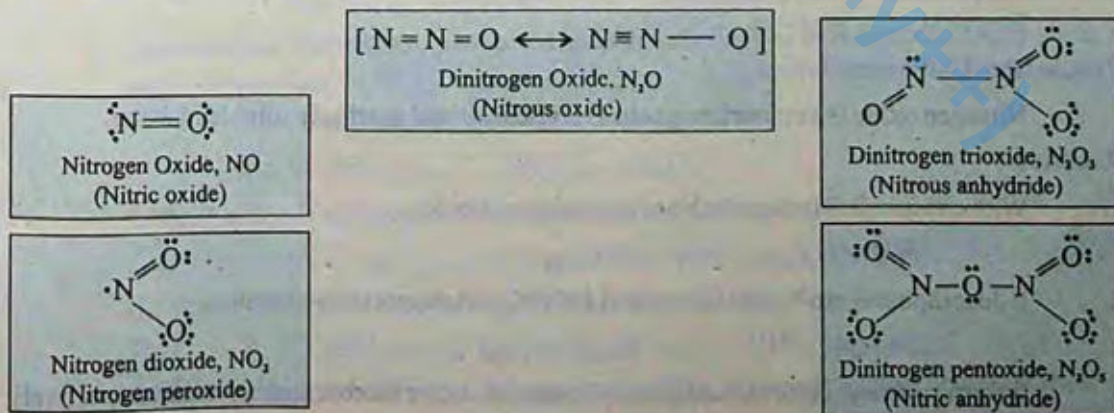
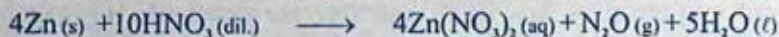

Fig. 4.1 Oxides of Nitrogen

## 1. Dinitrogen Oxide (N<sub>2</sub>O)

### Preparation

1. Dinitrogen oxide can be prepared by the action of dil. HNO<sub>3</sub> on metallic zinc.



2. It is usually prepared by heating ammonium nitrate to about 200°C.



To avoid the danger of explosion, ammonium nitrate can be replaced by a mixture of sodium nitrate and ammonium sulphate.

### Properties of Dinitrogen Oxide

Dinitrogen oxide is a colourless gas with a faint, pleasant smell and a sweetish taste. It is fairly soluble in cold water. Its mixture with a little oxygen, if inhaled for a sufficiently long time, produces hysterical laughter, hence it is also known as "laughing gas".

### Reactions

1. It is not combustible but resembles oxygen in rekindling a glowing splinter. Similarly, it supports combustion of burning substances, such as sulphur, phosphorus, etc. are taken in the cylinder containing this gas.



2. When N<sub>2</sub>O is passed over red hot copper, it is reduced to nitrogen.



## Nitrogen Oxide (NO)

### Preparation

1. Nitrogen oxide can be prepared by the action of dil HNO<sub>3</sub> on copper.

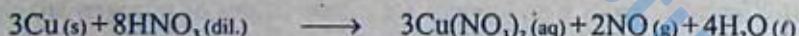

2. It can also be prepared by passing air through an electric arc.



### Properties of Nitrogen Oxide

Nitrogen oxide is a colourless gas heavier than air and sparingly soluble in water.

### Reactions

1. With oxygen, it forms reddish brown nitrogen dioxide.



2. It decomposes into N<sub>2</sub> and O<sub>2</sub> at about 1000°C and supports combustion.



3. It forms nitrosyl chloride and nitrosyl bromide with chlorine and bromine respectively in the presence of charcoal.

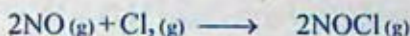

4. It forms a brown coloured addition compound with  $\text{FeSO}_4$ . This test is used to confirm the presence of nitrates (Ring Test).



5. With reducing agents, it is reduced to nitrous oxide or nitrogen.



6. Oxidizing agents can oxidize  $\text{NO}$  to  $\text{NO}_2$  or  $\text{HNO}_3$ .



### Nitrogen Dioxide ( $\text{NO}_2$ )

#### Preparation

1. It can be prepared in small quantities by heating lead nitrate.

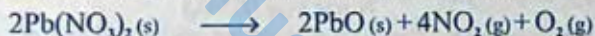

2. It can also be prepared by reacting conc.  $\text{HNO}_3$  with copper.

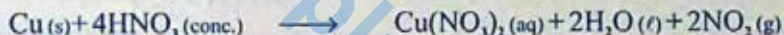

#### Properties of Nitrogen Dioxide

Nitrogen dioxide is a reddish brown gas with a pungent smell. It dissolves readily in water to form a blue acidic solution.

#### Reactions

1. On cooling,  $\text{NO}_2$  is converted into a yellow liquid which can be frozen to a colourless solid dinitrogen tetroxide ( $\text{N}_2\text{O}_4$ ). If this solid is heated to  $140^\circ\text{C}$ , the mixture contains  $\text{NO}_2$  and  $\text{N}_2\text{O}_4$  but at above  $140^\circ\text{C}$ ,  $\text{NO}_2$  is converted to  $\text{NO}$  and  $\text{O}_2$  molecules which are colourless. This decomposition is complete at  $620^\circ\text{C}$ .



2. Elements like phosphorus, potassium and carbon continue burning in  $\text{NO}_2$  as it yields  $\text{O}_2$  on decomposition.

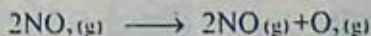

3. In the absence of air, it dissolves in water to form nitric and nitrous acids

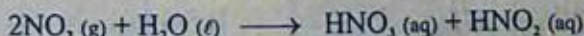

However in the presence of air or oxygen, nitric acid is the final product.



4. A mixture of nitrate and nitrite is formed when  $\text{NO}_2$  is passed through strong alkalis.

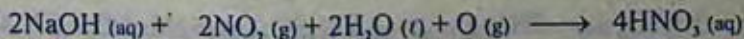

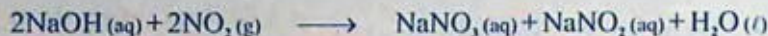

5. It is a strong oxidizing agent and oxidizes  $\text{H}_2\text{S}$  to sulphur, ferrous sulphate to ferric sulphate and KI to  $\text{I}_2$ .



### 4.2.3 Oxyacids of Nitrogen

There are two important oxyacids of nitrogen, nitrous acid and nitric acid.

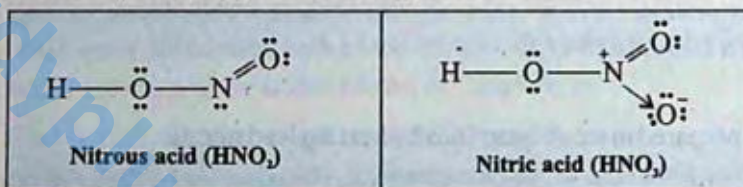

#### 1. Nitrous Acid ( $\text{HNO}_2$ )

##### Preparation

1. It can be prepared by dissolving dinitrogen trioxide in water at  $0^\circ\text{C}$ .

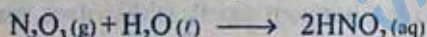

2. Pure nitrous acid solution can be prepared by reaction between ice cold barium nitrite solution and ice cold dilute sulphuric acid.



##### Properties of Nitrous Acid

It is only known in the form of its salts and is stable to some extent in a dilute solution.

##### Reactions

1. It begins to decompose almost as soon as it is formed even at ordinary temperature.

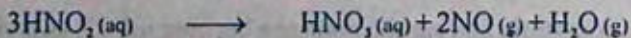

2. It acts as an oxidizing agent and oxidizes HI,  $\text{SO}_2$  and  $\text{SnCl}_2$  into  $\text{I}_2$ ,  $\text{H}_2\text{SO}_4$  and  $\text{SnCl}_4$ , respectively.

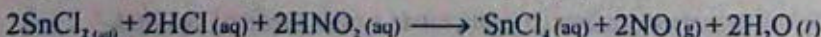
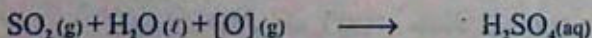

3. Nitrous acid decolourizes acidified  $\text{KMnO}_4$  and bromine water. It readily gets oxidized to nitric acid, so it also behaves as a reducing agent.

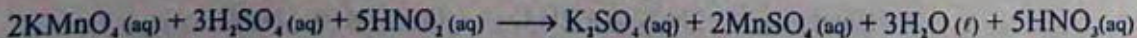

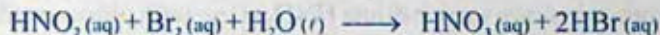

4. As an acid it reacts with alkalis producing salts.



5. It also reacts with organic compounds containing  $\text{NH}_2$  group and produces nitrogen.



### Nitric Acid ( $\text{HNO}_3$ )

#### Preparation

In the laboratory, nitric acid is prepared by heating potassium nitrate crystals with concentrated sulphuric acid.



#### Manufacture of Nitric Acid Birkeland and Eyde's process

This process consists of the following steps:

- (i) **Formation of nitric oxide**

Atmospheric nitrogen and oxygen are combined to give nitric oxide in an electric arc ( $3000^\circ\text{C}$ ).

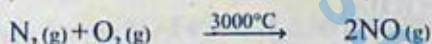

$\text{NO}$  formed is cooled quickly to  $1000^\circ\text{C}$  at which it does not decompose.

- (ii) At  $600^\circ\text{C}$ ,  $\text{NO}$  combines with  $\text{O}_2$  to form  $\text{NO}_2$ .

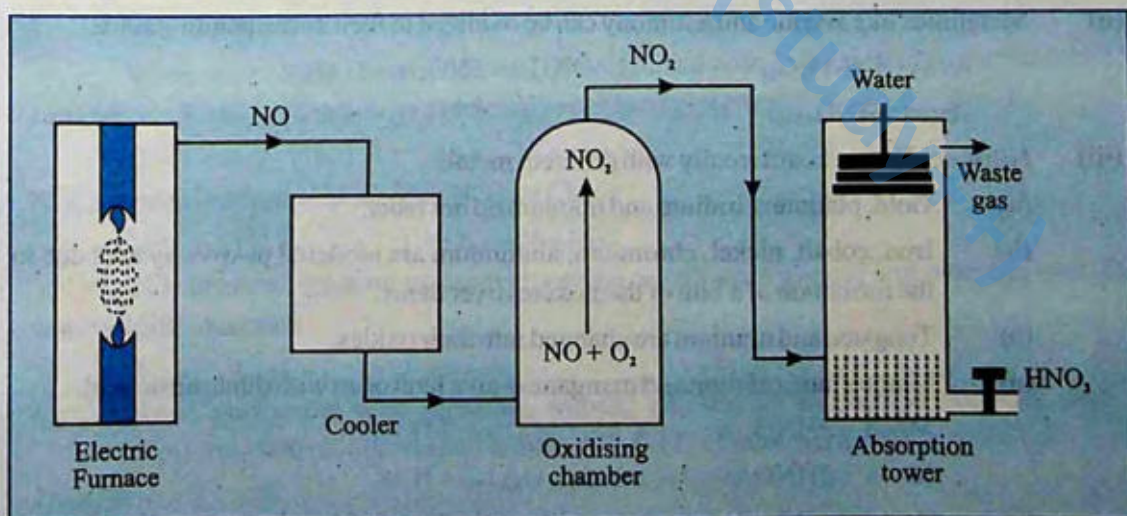
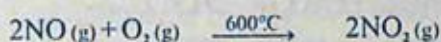

Fig. 4.2 Manufacture of nitric acid from air

(iii) Nitrogen dioxide is absorbed in water to give dilute  $\text{HNO}_3$  along with nitrous acid.



(iv) Nitrous acid is oxidized to nitric acid and nitric oxide which is re-oxidized to  $\text{NO}_2$ .



### Properties of Nitric Acid

Concentrated nitric acid is a colourless volatile liquid which fumes strongly in air. It has a pungent smell. Its specific gravity at  $15^\circ\text{C}$  is 1.53.

### Reactions

1. Nitric acid is decomposed in the presence of light even at ordinary temperature.



2. It is a very strong acid. It exhibits all the usual general properties of acids in all reactions where its oxidizing properties are not shown. It reacts in normal way with basic oxides, hydroxides and carbonates forming respective salts.



3. It acts as a strong oxidizing agent due to the ease with which it is decomposed.



(i) It oxidizes non-metals to their corresponding oxides.



(ii) Metalloids like arsenic and antimony can be oxidized to their corresponding acids.



(iii) Nitric acid behaves differently with different metals.

(a) Gold, platinum, iridium and titanium do not react.

(b) Iron, cobalt, nickel, chromium, aluminium are rendered passive by acid due to the formation of a film of their oxides over them.

(c) Tungsten and uranium are changed into their oxides.

(d) Magnesium, calcium and manganese give hydrogen with dilute nitric acid.



(e) Copper and lead give nitric oxide with dilute acid and nitrogen dioxide with concentrated acid.

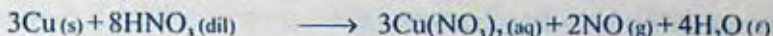

- (f) Mercury gives mercurous nitrate and nitric oxide with dilute nitric acid.

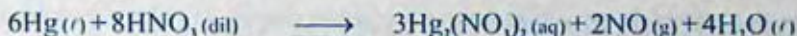

With concentrated acid, it gives mercuric nitrate and nitrogen dioxide.

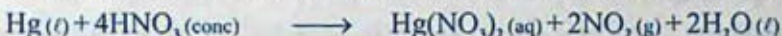

- (g) Silver reacts with nitric acid to give silver nitrate and nitric oxide.



- (h) Dilute nitric acid gives ammonium nitrate, when it reacts with tin. With concentrated acid meta-stannic acid is produced.

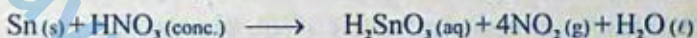
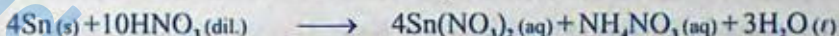

- (i) Zinc gives different products depending upon the concentration of acid and temperature. Very dilute nitric acid gives  $\text{NH}_4\text{NO}_3$ . Moderately dilute nitric acid gives nitrous oxide while concentrated nitric acid gives  $\text{NO}_2$ .

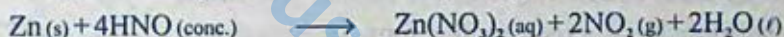
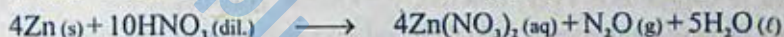
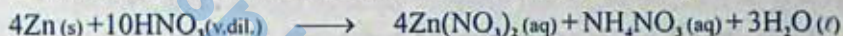

- 4 Reducing agents like  $\text{FeSO}_4$ ,  $\text{H}_2\text{S}$  and  $\text{HI}$  are converted to  $\text{Fe}_2(\text{SO}_4)_3$ ,  $\text{S}$  and  $\text{I}_2$  respectively, when they react with conc.  $\text{HNO}_3$ .



## 5 Aqua Regia

When one volume of concentrated  $\text{HNO}_3$  is mixed with 3 volumes of concentrated  $\text{HCl}$ , aqua regia is formed. It is employed to dissolve gold and platinum.



$\text{NOCl}$  formed is decomposed giving  $\text{NO}$  and  $\text{Cl}_2$ .



This liberated chlorine gas converts noble metals such as gold and platinum into their water soluble chlorides.

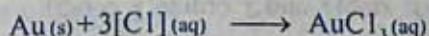

6. Nitric acid reacts with glycerine, toluene and phenol to prepare materials used as explosives like nitroglycerine, trinitrotoluene (TNT) and picric acid, respectively.

## Uses

It is used:

1. as a laboratory reagent.

2. in the manufacture of nitrogen fertilizers.
3. in the manufacture of explosives.
4. for making varnishes and organic dyes.

### 4.3 PHOSPHORUS AND ITS COMPOUNDS

#### 4.3.1 Occurrence

Phosphorus is the second member of group VA. Its name comes from Greek word meaning "Light bearing". Unlike, nitrogen it does not occur in free state in nature. Most of the phosphorus is found in deposits of phosphate rock, i.e., impure  $\text{Ca}_3(\text{PO}_4)_2$  and apatite  $\text{Ca}_5\text{F}(\text{PO}_4)_3$ .

As a constituent of plant and animal tissues, it is essential for their normal growth. It occurs especially in seeds, the yolk of eggs, the nerves, brain and bone marrows, usually in the form of lecithins. In the form of calcium phosphate, it is an essential constituent of bones. Bone ash (80% calcium phosphate) is an important source of phosphorus.

#### 4.3.2 Allotropes of Phosphorus

Phosphorus can exist in at least six different solid allotropic forms, of which we will mention only three.

White phosphorus is a very reactive, poisonous, volatile, waxy, yellowish white substance, which is soluble in benzene and carbon disulphide. It exists in the form of tetraatomic molecules ( $\text{P}_4$ ) which have a tetrahedral structure, Fig. 4.3. It boils at  $280^\circ\text{C}$  to  $\text{P}_4$  vapours which dissociate above  $700^\circ\text{C}$  to form  $\text{P}_2$  molecules. Red phosphorus is much less reactive and less poisonous than white phosphorus. It is prepared by heating white phosphorus in the presence of a little iodine or sulphur as a catalyst upto  $250^\circ\text{C}$  in vacuum. The tetraatomic molecules of red phosphorus combine to form macromolecules, Fig. 4.4.

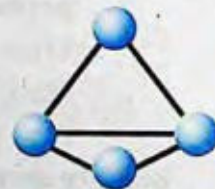

Fig.4.3 White phosphorus



Fig.4.4 Red Phosphorus

Black phosphorus is the third form which is most stable under ordinary conditions. Black phosphorus is prepared by heating red phosphorus to high temperature and pressure.

#### 4.3.3 Halides of Phosphorus

##### Phosphorus Trichloride ( $\text{PCl}_3$ )

##### Preparation

1. It is usually prepared by melting white phosphorus in a retort in an inert atmosphere of

CO<sub>2</sub> and current of dried chlorine is passed over it. The vapours of PCl<sub>3</sub> are collected in a flask kept in an ice-bath.

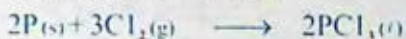

2. It may also be prepared by the action of phosphorus with thionyl chloride.

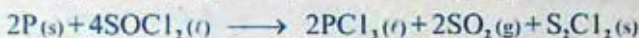

### Properties of Phosphorus Trichloride

It is a colourless fuming liquid which boils at 76°C and freezes at -112°C.

### Reactions

1. It combines with chlorine to form phosphorus pentachloride

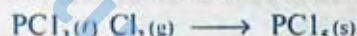

2. It combines with atmospheric oxygen slowly to form phosphorus oxychloride.



3. It is soluble in organic solvents, but readily reacts with water to form phosphorus acid.



4. It reacts with alcohols and carboxylic acids forming the respective chloro derivatives and H<sub>3</sub>PO<sub>3</sub>.

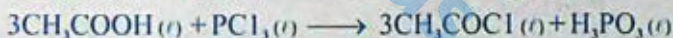

### Phosphorus Pentachloride (PCl<sub>5</sub>)

### Preparation

1. By passing dry chlorine through phosphorus trichloride.

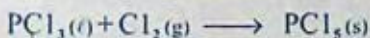

2. It may also be prepared by passing dry chlorine in a well cooled solution of phosphorus in carbon disulphide.

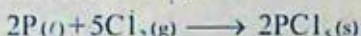

### Properties of Phosphorus Pentachloride

1. It is a yellowish white crystalline solid which sublimes at about 100°C. It gives fumes in moist air with an irritating smell.

### Reactions

1. It decomposes on heating producing PCl<sub>3</sub> and chlorine.

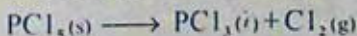

2. It gets decomposed by water forming phosphorus oxychloride which further reacts with water to produce orthophosphoric acid.



3. It converts metals into their chlorides.



#### 4.3.4 Oxides of Phosphorus

##### Phosphorus Trioxide, $\text{P}_2\text{O}_3$ ( $\text{P}_4\text{O}_6$ )

##### Preparation

1.  $\text{P}_2\text{O}_3$  can be prepared by burning white phosphorus in a limited supply of air.

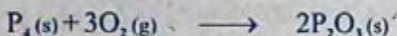

##### Properties of Phosphorus Trioxide

It is a white waxy solid with garlic like odour. It melts at  $22.8^\circ\text{C}$  and boils at  $173^\circ\text{C}$ . It is highly poisonous in nature.

##### Reactions

1. When heated in the presence of air or oxygen, it is converted into phosphorus pentoxide.



2. It reacts with cold water to give phosphorus acid.



With hot water, it forms phosphine and phosphoric acid.



##### Phosphorus Pentoxide, $\text{P}_2\text{O}_5$ or $\text{P}_4\text{O}_{10}$

##### Preparation

1. It is prepared by burning phosphorus in excess of dry air.



##### Properties of Phosphorus Pentoxide

It is a white hygroscopic powder having a faint, garlic like odour due to the presence of traces of  $\text{P}_2\text{O}_3$ . It sublimes at  $360^\circ\text{C}$ .

##### Reactions

1. With cold water phosphorus pentoxide forms metaphosphoric acid.



With hot water, it forms orthophosphoric acid



2. It is a powerful dehydrating agent, thus, with  $\text{HNO}_3$ ,  $\text{H}_2\text{SO}_4$ ,  $\text{CH}_3\text{COOH}$  and  $\text{C}_2\text{H}_5\text{OH}$ , it gives  $\text{N}_2\text{O}_5$ ,  $\text{SO}_3$ ,  $(\text{CH}_3\text{CO})_2\text{O}$  and  $\text{C}_2\text{H}_4$ , respectively.





### 4.3.5 Oxyacids of Phosphorus

#### Phosphorus Acid ( $\text{H}_3\text{PO}_3$ )

##### Preparation

1. It is prepared by dissolving phosphorus trioxide in cold water.

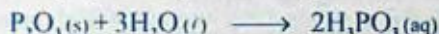

2. It is also obtained by the hydrolysis of phosphorus trichloride.



##### Properties of Phosphorus Acid

It is a white crystalline solid, which melts at  $73.6^\circ\text{C}$ .

##### Reactions

1. It decomposes into phosphine and orthophosphoric acid on heating.

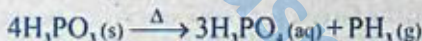

2. It is a powerful reducing agent and reduces  $\text{CuSO}_4$ ,  $\text{AgNO}_3$ , etc. to the metallic state.

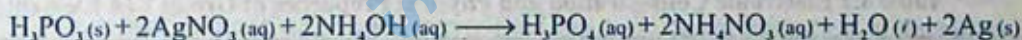

3. It reacts with oxygen to form orthophosphoric acid.

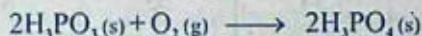

4. Nascent hydrogen produced by  $\text{Zn}/\text{HCl}$  reduces  $\text{H}_3\text{PO}_3$  to phosphine



#### Orthophosphoric Acid ( $\text{H}_3\text{PO}_4$ )

##### Preparation

1. It is prepared by dissolving phosphorus pentoxide in hot water.



2. It is also obtained by heating red phosphorus with concentrated  $\text{HNO}_3$ .

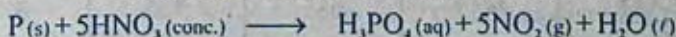

3. Hydrolysis of phosphorus pentachloride also gives orthophosphoric acid.

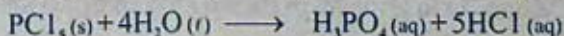

4. On large scale, it can be prepared by heating a mixture of phosphorite (bone ash) and sand in an electric furnace. The phosphorus pentoxide formed is treated with hot water to obtain phosphoric acid.

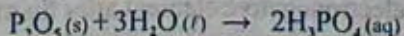

### Properties of Orthophosphoric Acid

It is a colourless, deliquescent crystalline solid which melts at 41°C. It is soluble in water.

#### Reactions

1. It is a weak tribasic acid. It reacts with NaOH to give three series of salts.

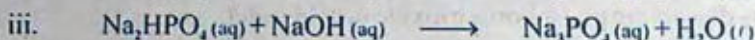

2. On heating, it loses water and converted into pyro and metaphosphoric acid.

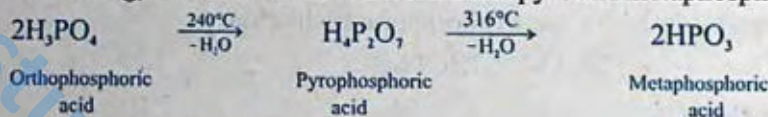

## GROUP VIA ELEMENTS

### 4.4 Group VIA Elements

The group VIA of the periodic table consists of oxygen, sulphur, selenium, tellurium and polonium. These elements are called chalcogens from the Greek for "copper giver", because they are often found in copper ores. The electronic configuration and physical properties of group VIA elements are shown in Table 4.2.

Table 4.2 Electronic Configuration and Physical Properties of Group VIA Elements

Properties	O	S	Se	Te	Po
Atomic number	8	16	34	52	84
Electronic configuration	[He]2s <sup>2</sup> 2p <sup>4</sup>	[Ne]3s <sup>2</sup> 3p <sup>4</sup>	[Ar]4s <sup>2</sup> 4p <sup>4</sup>	[Kr]5s <sup>2</sup> 5p <sup>4</sup>	[Xe]6s <sup>2</sup> 6p <sup>4</sup>
Ionization energy (kJ/mol)	1314	999	941	869	813
Electron affinity (kJ/mol)	-141.1	-200.42	-195	-183	-180
Electronegativity	3.5	2.5	2.4	2.1	2.0
Atomic radius(pm)	73	103	119	142	168
Ionic radius 2-ion (pm)	140	184	198	221	94
Melting points (°C)	-219	113	217	452	254
Boiling points (°C)	-183	444.6	685	990	962
Density (g/cm <sup>3</sup> )	0.00143	2.06	4.28	6.25	9.14

#### 4.4.1 General Characteristics

All the elements of group VIA are non-metals except Po which is a radioactive metal. Atomic radii, density, melting and boiling points generally increase with increase in atomic number down the group. Ionization energies of the group members are very high which shows their reluctance to lose electrons. Oxygen is the most electronegative element after fluorine. All

these elements show the property of allotropy. Oxygen has two allotropic forms ( $O_2$  and  $O_3$ ), sulphur has 3 ( $\alpha$ ,  $\beta$ ,  $\gamma$ ), Se has two (red and grey), Te has two (metallic and non-metallic).

They also show the property of catenation. This property decreases down the group. All the elements are polymeric in nature (they form poly-atomic molecules). They attain the electronic configuration of the nearest noble gas by gaining 2 electrons forming  $O^{2-}$ ,  $S^{2-}$ ,  $Se^{2-}$ , etc. Except oxygen the other members of the group show a covalency of +2, +4, and +6, for example,  $SCl_2$ ,  $SCl_4$ ,  $SCl_6$ . +2 oxidation state is shown due to 2 unpaired electrons in the p-orbitals. +4 oxidation state is shown when 1 electron from p-orbital is promoted to the next vacant d-orbital, while +6 oxidation state is shown when another electron from s-orbital is also promoted to the next vacant d-orbital.

#### 4.4.2 Occurrence

Oxygen is the most widely distributed and common of all the elements, comprising about 50% of the earth's crust. About one-fourth of the atmospheric air by weight consists of free oxygen and water contains nearly 89% of combined oxygen.

The calcium carbonate which occurs as chalk, limestone, marble etc, contains 48% oxygen. Silica which is found in flint, quartz, etc, contains more than 53% oxygen by weight.

Sulphur is also widely distributed in nature both as free and in combined forms. Many important metallic ores are sulphides, e.g. galena ( $PbS$ ), Zinc blende ( $ZnS$ ), cinnabar ( $HgS$ ), stibnite ( $Sb_2S_3$ ), copper pyrite ( $Cu_2S.Fe_2S_3$ ), iron pyrite ( $FeS_2$ ), etc. Some important sulphates are also found in nature, e.g. gypsum ( $CaSO_4$ ), heavy spar ( $BaSO_4$ ), etc.

Sulphur also occurs in organic compounds present in animals and vegetables. Onions, garlic, mustard, hair, many oils, eggs and proteins consist of compounds containing sulphur in them. It also occurs as a constituent of coal and petroleum.

#### 4.4.3 Comparison of Oxygen and Sulphur

##### Similarities:

1. Both oxygen and sulphur have same outer electronic configuration of  $ns^2np^4$ .
2. Both oxygen and sulphur are usually divalent.
3. Both oxygen and sulphur exhibit allotropic forms.
4. Both have polyatomic molecules. Oxygen has diatomic  $O_2$ , while sulphur has  $S_2$  and  $S_8$  molecules.
5. Both combine with metals in the form of  $O^{2-}$  and  $S^{2-}$  with oxidation state -2.
6. Both combine with non-metals and form covalent compounds, e.g.  $H_2O$  and  $H_2S$ ,  $CO_2$  and  $CS_2$ , etc.
7. Both are typical non-metals.
8. Both are found in free and combined states on earth.

**Dissimilarities:**

Sr. #	Oxygen	Sulphur
1.	There are two allotropic forms of Oxygen- $O_2$ and $O_3$ .	There are 3 allotropic forms of sulphur, rhombic, monoclinic and plastic.
2.	It is gas at ordinary temperature.	It is solid at ordinary temperature.
3.	Oxygen is sparingly soluble in water.	Sulphur is not soluble in water.
4.	Oxygen helps in combustion.	Sulphur is itself combustible.
5.	It is paramagnetic in nature.	It is diamagnetic in nature.
6.	It does not react with water.	When steam is passed through boiling sulphur a little hydrogen sulphide and sulphur dioxide are formed.
7.	It does not react with acids.	It is readily oxidized by conc. sulphuric acid or nitric acid.
8.	It does not react with alkalis.	It reacts with alkali solution and forms sulphides and thiosulphate.
9.	It shows -2 oxidation state.	It shows oxidation states of -2, +2, +4 and +6.

**4.5 SULPHURIC ACID ( $H_2SO_4$ )**

Sulphuric acid was first prepared by a Muslim scientist Jabir bin Hayyan in 8th century. In Europe, in 14<sup>th</sup> and 15<sup>th</sup> centuries, its preparation on commercial level was started due to the awareness of its properties and uses. It was called "oil of vitriol".

It does not occur as such in nature, however, small quantities of  $H_2SO_4$  are found in the waters of some springs and rivers.

**4.5.1 Manufacture of Sulphuric Acid**

Sulphuric acid is being manufactured commonly by contact process.

**Contact Process**

This method was developed by Knietzsch in Germany. Basically, it involves the catalytic combination of sulphur and oxygen to form  $SO_2$ , which is then dissolved in water to form  $H_2SO_4$ .

**Principle**

$SO_2$  obtained by burning sulphur or iron pyrites is oxidized to  $SO_3$  in the presence of  $V_2O_5$ , which acts as a catalyst. The best yield of  $SO_3$  can be obtained by using excess of oxygen or air and keeping the temperature between 400-500°C.

$SO_3$  formed is absorbed in concentrated  $H_2SO_4$  and "Oleum" ( $H_2S_2O_7$ ) formed can be converted to sulphuric acid of any strength by mixing adequate quantities of water.

The process is completed in the steps given below.

**a. Sulphur Burners**

Sulphur or iron pyrites are burnt in excess of air to produce  $\text{SO}_2$ .



**b. Purifying Unit**

$\text{SO}_2$  is purified from impurities like dust and arsenic oxide, to avoid poisoning of the catalyst. Purifying unit consists of the following parts.

**(i) Dust remover**

Steam is injected to remove dust particles from the gases.

**(ii) Cooling Pipes**

The gases are passed through lead pipes to cool them to  $100^\circ\text{C}$ .

**(iii) Scrubbers**

The cooled gases are washed by a spray of water, as  $\text{SO}_2$  is not soluble in water at high temperature.

**(iv) Drying Tower**

The moisture of gases is removed by concentrated  $\text{H}_2\text{SO}_4$  trickling down through the coke filled in this tower.

**(v) Arsenic Purifier**

Arsenic oxide is then removed by passing the gases through a chamber provided with shelves packed with freshly prepared ferric hydroxide.

**(vi) Testing box**

In this box a beam of light is introduced which indicates the presence or absence of solid particles. If present the gases are sent back for further purification.

**c. Contact Tower**

Preheated gases at  $400\text{--}500^\circ\text{C}$  are passed through vertical iron columns packed with the catalyst  $\text{V}_2\text{O}_5$ . Here  $\text{SO}_2$  is oxidized to  $\text{SO}_3$ .

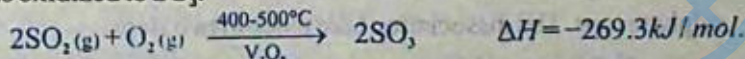

The reaction is highly exothermic so no heating is required once the reaction is started.

**d. Absorption Unit**

The  $\text{SO}_3$  obtained from the contact tower is dissolved in 98%  $\text{H}_2\text{SO}_4$  to form pyrosulphuric acid (oleum),  $\text{H}_2\text{S}_2\text{O}_7$ . It can be diluted with water to get any required concentration of sulphuric acid.

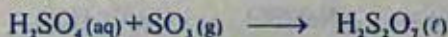

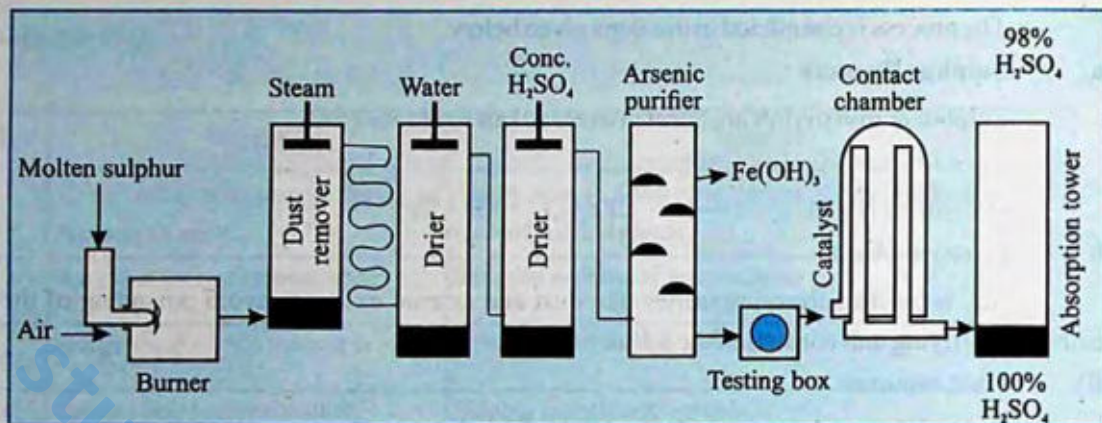

Fig.4.5 Contact Process

### 4.5.2 Properties

#### Physical Properties

1. Pure sulphuric acid is a colourless oily liquid without an odour.
2. Its specific gravity is 1.834 at 18°C.
3. It freezes at 10.5°C.
4. Its boiling point is 338°C.
5. It dissolves in water liberating a lot of heat which raises the temperature of the mixture up to 120°C.  $\text{H}_2\text{SO}_4$  should always be poured in water in a thin stream to avoid any accident.
6. Pure acid is a nonconductor of electricity but the addition of a little water makes it a good conductor.
7. It is extremely corrosive to skin and causes very serious burns to all the tissues.

#### Reactions

1. It is stable at ordinary temperature but on strong heating it dissociates into  $\text{SO}_3$  and  $\text{H}_2\text{O}$ .

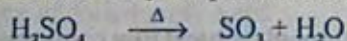

2. It is a strong acid. In an aqueous solution it completely ionizes to give hydronium and sulphate ions. The dissociation takes place in two steps.

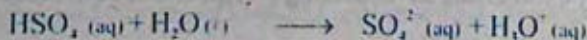

3. Reaction as an Acid

#### (i) Reactions with alkalis

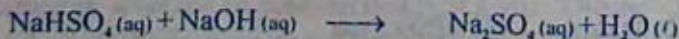

## (ii) Reactions with carbonates and hydrogen carbonates

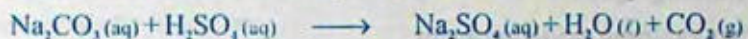

## (iii) Reactions with salts



## (iv) Reaction with metals

(a) Cold dilute acid reacts with almost all metals to produce hydrogen gas and sulphate salts.

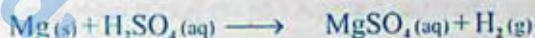
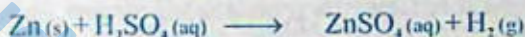
(b) Cold concentrated  $\text{H}_2\text{SO}_4$  does not react with most of the metals like Cu, Ag, Hg, Pb, Au.(c) With certain metals hot concentrated sulphuric acid gives metal sulphates, water and  $\text{SO}_2$ .

## 4. Reactions as a Dehydrating Agent

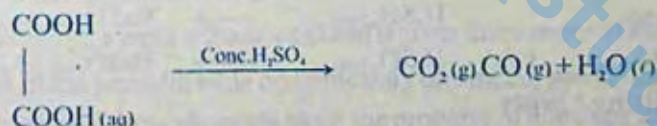
 $\text{H}_2\text{SO}_4$  has a great affinity for water, so it acts as dehydrating agent and eliminates water from different compounds.(i) With oxalic acid it forms  $\text{CO}_2$  and CO.

(ii) With formic acid, CO is formed.

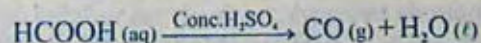

(iii) With ethyl alcohol it forms ethylene.

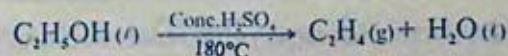

(iv) With wood, paper, sugar and starch it forms carbon and water.

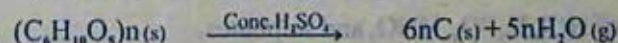
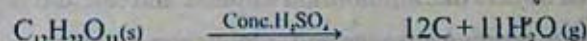
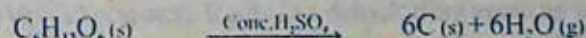

### 5. As an Oxidizing Agent

$\text{H}_2\text{SO}_4$  acts as a strong oxidizing agent.

- (i) It oxidizes C and S giving  $\text{CO}_2$  and  $\text{SO}_2$ , respectively.



- (ii)  $\text{H}_2\text{S}$  is oxidized to Sulphur.



- (iii) Reactions of  $\text{H}_2\text{SO}_4$  with HBr and HI produces bromine and iodine respectively.



### 6. Reactions with Gases

- (i) It absorbs  $\text{SO}_3$  and forms oleum.

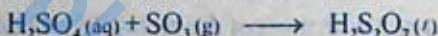

- (ii) It reacts with ammonia forming ammonium sulphate.

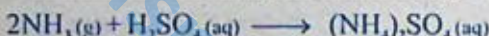

### 7. Reaction with Benzene

Benzene sulphonic acid is produced when conc.  $\text{H}_2\text{SO}_4$  reacts with benzene.



Benzene sulphonic acid

### 8. Precipitation Reactions

White precipitates are produced when  $\text{H}_2\text{SO}_4$  reacts with solutions of  $\text{BaCl}_2$ ,  $\text{Pb}(\text{NO}_3)_2$  and  $\text{Sr}(\text{NO}_3)_2$ .

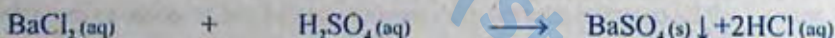

### 9. Reactions with Oxidizing Agents

It reacts with oxidizing agents like  $\text{KMnO}_4$  and  $\text{K}_2\text{Cr}_2\text{O}_7$ , to liberate oxygen which may oxidize other compounds.

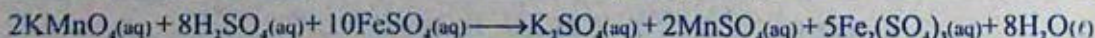

### 4.5.3 Uses of Sulphuric Acid

It is used:

1. in the manufacture of fertilizers like ammonium sulphate and calcium superphosphate.
2. in refining of petroleum to remove nitrogen and sulphur compounds.
3. in the manufacture of  $\text{HCl}$ ,  $\text{H}_3\text{PO}_4$ ,  $\text{HNO}_3$  and sulphates.

4. in the manufacture of many chemicals, dyes, drugs, plastics, disinfectants, paints, explosives, synthetic fibres, etc.
5. in electrical batteries and storage cells.
6. as a dehydrating agent for drying gases.
7. as a laboratory reagent.
8. in textile, iron, steel, leather and paper industries.

### KEY POINTS

1. In group VA the metallic character increases down the group. Nitrogen and phosphorus are non-metals, arsenic and antimony are metalloids while bismuth is a metal.
2. Phosphorus and other members of VA group can make use of d-orbitals in bonding.
3. Common oxides of nitrogen are  $N_2O$ ,  $NO$ ,  $NO_2$ ,  $N_2O_3$  and  $N_2O_5$ .
4. Nitrogen forms two oxyacids,  $HNO_2$  and  $HNO_3$ ,  $HNO_2$  is an unstable acid and exists only in solution.
5.  $HNO_3$  is not only a strong acid but it also acts as a strong oxidising agent.
6. Aqua regia is a mixture of one volume of concentrated  $HNO_3$  and three volumes of concentrated  $HCl$ .
7. Phosphorus exists in six allotropic forms. White phosphorus is very reactive as compared to red phosphorus.
8. Phosphorus forms two types of chlorides  $PCl_3$ ,  $PCl_5$  and two types of oxides  $P_2O_3$  and  $P_2O_5$ .
9. Just like nitrogen, phosphorus also gives two types of oxyacids; phosphorus acid ( $H_3PO_3$ ) and phosphoric acid ( $H_3PO_4$ ).
10. Phosphoric acid is a weak tribasic acid and it gives three series of salts with strong base.
11. Group VIA of the periodic table contains only one metal, polonium, the rest of members are non-metals. All these elements show the property of allotropy and they are polymeric in nature.
12. Oxygen and sulphur are the most abundant elements of group VIA. Oxygen is the most widely distributed of all the elements. Sulphur is widely distributed in nature in both free and combined forms.
13. Sulphuric acid is commercially prepared by oxidation of  $SO_2$  in the presence of a catalyst to  $SO_3$  in a process called Contact Process.
14.  $H_2SO_4$  is a very strong acid. It acts as a dehydrating agent as well as an oxidizing agent.

## EXERCISE

Q.1 Fill in the blanks.

- (i) The elements \_\_\_\_\_ of group VA are called metalloids.
- (ii) In Birkeland and Eyde's process \_\_\_\_\_ is prepared from atmospheric oxygen and nitrogen.
- (iii) The tendency to form long chain of atoms is called \_\_\_\_\_.
- (iv) All the elements of group VIA show the property of \_\_\_\_\_.
- (v) Selenium shows two allotropic forms which are called \_\_\_\_\_ forms.
- (vi) Specific gravity of  $H_2SO_4$  at  $18^\circ C$  is \_\_\_\_\_.
- (vii)  $H_2$  is produced by reacting  $H_2SO_4$  with metals, like \_\_\_\_\_.
- (viii) The elements of group VA exhibit maximum oxidation state of \_\_\_\_\_.
- (ix) The outermost shell of group \_\_\_\_\_ elements contains six electrons.
- (x) Oxygen shows \_\_\_\_\_ behaviour due to the presence of unpaired electrons.
- (xi) Conc. phosphoric acid acts as a \_\_\_\_\_.
- (xii) Nitrogen is a gas while other elements of the same group are \_\_\_\_\_.
- (xiii) Noble metals like gold and platinum are dissolved in \_\_\_\_\_.
- (xiv) Sulphur is different from oxygen because it shows \_\_\_\_\_ oxidation states.
- (xv)  $HNO_3$  is used in the manufacture of \_\_\_\_\_ fertilizers.

Q.2 Indicate True or False.

- i) The metallic character in groups VA and VIA elements increases down the group.
- ii) The elements of group VA exhibit maximum oxidation state of +5.
- iii) Ionization energy of phosphorus is greater than that of nitrogen.
- iv) The electronegativity of oxygen is greater than all other elements of groups VA and VIA.
- v)  $V_2O_5$  is used as a catalyst for the oxidation of  $SO_2$  to  $SO_3$ .
- vi) The oxides of nitrogen are basic in nature.
- vii) Aqua regia is prepared by mixing 3 parts of conc.  $HNO_3$  with one part of conc.  $HCl$ .
- viii) TNT is prepared by the reaction of nitric acid with toluene.
- ix)  $P_2O_5$  when reacts with cold water gives phosphorus acid and with hot water it gives phosphoric acid.
- x) Sulphur occurs in many organic compounds of animal and vegetable origins.

- Q.3 Multiple choice question. Encircle the correct answer.
- (i) Out of all the elements of group VA, the highest ionization energy is possessed by:  
(a) N (b) P (c) Sb (d) Bi
- ii) Among group VA elements, the most electronegative element is:  
(a) Sb (b) N (c) P (d) As
- iii) Oxidation of NO in air produces:  
(a)  $N_2O$  (b)  $N_2O_3$  (c)  $N_2O_4$  (d)  $N_2O_5$
- iv) The brown gas formed, when metal reduces  $HNO_3$ , to:  
(a)  $N_2O_5$  (b)  $N_2O_3$  (c)  $NO_2$  (d)  $NO$
- v) Laughing gas is chemically:  
(a)  $NO$  (b)  $N_2O$  (c)  $NO_2$  (d)  $N_2O_4$
- (vi) Out of all the elements of group VIA, the highest melting and boiling points is shown by the element:  
(a) Te (b) Se (c) S (d) Pb
- vii)  $SO_3$  is not absorbed in water directly to form  $H_2SO_4$ , because:  
(a) the reaction does not go to completion.  
(b) the reaction is quite slow.  
(c) the reaction is highly exothermic.  
(d)  $SO_3$  is insoluble in water.
- ix) Which catalyst is used in contact process?  
(a)  $Fe_2O_3$  (b)  $V_2O_5$  (c)  $SO_3$  (d)  $Ag_2O$
- x) Which of the following species has the maximum number of unpaired electrons?  
(a)  $O_2$  (b)  $O_2^+$  (c)  $O_2^-$  (d)  $O_2^{2-}$
- Q.4 Short answer questions.
- (i) How does nitrogen differ from other elements of its group?  
ii) Why does aqua regia dissolve gold and platinum?  
iii) Why the elements of group VIA other than oxygen show more than two oxidation states?  
iv) Write down a comparison of the properties of oxygen and sulphur.  
v) Write down the equation for the reaction between conc.  $H_2SO_4$  and copper and explain what type of reaction is it.
- Q.5 (a) Explain the Birkeland and Eyde's process for the manufacture of nitric acid.  
(b) Which metals evolve hydrogen upon reaction with nitric acid? Illustrate alongwith chemical equations.

- (c) What is meant by fuming nitric acid?
- Q.6 (a) Sulphuric acid is said to act as an acid, an oxidizing agent and a dehydrating agent, describe two reactions in each case to illustrate the truth of this statement.
- (b) Give the advantages of contact process for the manufacture of sulphuric acid.
- Q.7 (a) Describe the chemistry of the industrial preparation of sulphuric acid from sulphur by the contact process.
- (b) Why is  $\text{SO}_3$  dissolved in  $\text{H}_2\text{SO}_4$  and not in water?
- (c) Explain the action of sulphuric acid on metals along with chemical equations.
- Q.8 Describe the preparation of  $\text{NO}_2$  gas. Also give its reactions.
- Q.9 How  $\text{PCl}_1$  and  $\text{PCl}_2$  can be used for the preparation of other chemical compounds.
- Q.10 Answer the following questions.
- Describe "Ring test" for the confirmation of the presence of nitrate ions in solution.
  - $\text{NO}_2$  is a strong oxidizing agent. Prove the truth of this statement giving examples.
  - Write down the chemical equations and names of the products formed as a result of the reaction of  $\text{HNO}_3$  with arsenic and antimony.
  - Give the methods of preparation of  $\text{PCl}_1$ .
  - $\text{P}_2\text{O}_5$  is a powerful dehydrating agent. Prove it giving example.
- Q.11 Complete and balance the following chemical equations.
- $\text{P} + \text{NO} \longrightarrow$
  - $\text{NO} + \text{Cl}_2 \longrightarrow$
  - $\text{H}_2\text{S} + \text{NO} \longrightarrow$
  - $\text{Pb}(\text{NO}_3)_2 \longrightarrow$
  - $\text{NO}_2 + \text{H}_2\text{O} \longrightarrow$
  - $\text{NO}_2 + \text{H}_2\text{SO}_4 \longrightarrow$
  - $\text{HNO}_3 + \text{HI} \longrightarrow$
  - $\text{HNO}_2 + \text{NH}_3 \longrightarrow$
  - $\text{HNO}_2 + \text{CO}(\text{NH}_2)_2 \longrightarrow$
  - $\text{KNO}_3 + \text{H}_2\text{SO}_4 \longrightarrow$
- Q.12 Describe the methods of preparation of phosphorus pentoxide and explain its reactions.
- Q.13 Discuss the trends in physical properties of group VIA elements.

## CHAPTER

## 5

**THE HALOGENS AND  
THE NOBLE GASES****In this chapter you will learn**

1. The electronic configurations and the occurrence of halogens, the peculiar behaviour of fluorine.
2. The volatility of halogens and its explanation in terms of van der Waal's forces.
3. The relative reactivities of halogens as oxidizing agents.
4. The properties of hydrogen halides, oxides and oxyacids of halogens.
5. The comparison of thermal stability of hydrides in terms of bond energies.
6. Reaction of chlorine with sodium hydroxide (hot/cold).
7. The preparation and reaction of bleaching powder.
8. The commercial uses of halogens and their compounds as bleaches, refrigerants, aerosols and anaesthetics.
9. The electronic configurations, physical properties, inertness and isolation of noble gases from air.
10. The properties of oxides, fluorides and oxyfluorides of xenon

**5.1 INTRODUCTION**

The elements fluorine (F), chlorine (Cl), bromine (Br), iodine (I) and astatine (At) are called halogens. These elements are called the halogens from Greek *hals*, "salt" and *gennan*, "to form or generate", because they are literally the salt formers. The halogen elements form a group of very reactive non-metals and are quite similar to each other in their chemical properties. First four elements are the common elements of the halogen family but astatine is a rare halogen. It is radioactive and its most stable isotope has a half life of only 8.3 hrs.

Halogens exist as discrete diatomic molecules in all phases (gas, liquid or solid). Fluorine and chlorine are gases of pale yellow and greenish yellow colours respectively at room temperature and pressure. Bromine is a liquid of red-brown colour and iodine is a metallic-appearing shiny greyish black solid. The halogens have irritating odours, and they attack the skin. Bromine in particular causes burns that heal slowly. The outer shell of halogens have the configuration  $ns^2 np^5$  (one electron short of the stable octet of the noble gases). The electronic configurations and the important physical properties of the halogens are given in the Table 5.1.

The ionization energy data of the halogens shows that the fluorine atom holds its electrons tightly whereas the electrons are least tightly bound in iodine. The trend can be correlated with the sizes of the halogen atoms as shown in the Table 5.1.

The electron affinity values of halogens are large and negative, that is why halogens gain electrons readily. They have large, positive standard electrode potentials and their electronegativities are also fairly high.

The intermolecular attraction is greater in the larger molecules having greater masses. Due to their large size, the van der Waal's forces in iodine molecules are stronger than in the smaller molecules of the other halogens.

**Table 5.1 The Electronic Configurations and the Important Physical Properties of the Halogens.**

Properties	Fluorine	Chlorine	Bromine	Iodine
Atomic number	9	17	35	53
Electronic configuration	[He]2s <sup>2</sup> 2p <sup>5</sup>	[Ne]3s <sup>2</sup> 3p <sup>5</sup>	[Ar]3d <sup>10</sup> 4s <sup>2</sup> 4p <sup>5</sup>	[Kr]4d <sup>10</sup> 5s <sup>2</sup> 5p <sup>5</sup>
Physical appearance	Pale Yellow gas	Greenish yellow gas	Red-brown liquid	Shiny greyish black solid
Ionization energy(kJ mol <sup>-1</sup> )	1681	1251	1143	1009
Electron affinity, (kJ mol <sup>-1</sup> )	-322	-349	-325	-295
Electronegativity	4.00	3.00	2.8	2.5
Ionic radius (pm)	133	181	196	220
Covalent radius (pm)	72	100	114	133
Melting point (°C)	-219	-101	-7.2	114
Boiling point (°C)	-188	-34.1	59.5	185
Density (g/cm <sup>3</sup> )	0.00181	0.00321	3.12	4.93
Oxidation states	-1	-1,+1,+3,+5,+7	-1,+1,+3,+5,+7	-1,+1,+3,+5,+7
Bond energy (kJ mol <sup>-1</sup> ) (X-X)	154.80	242.67	192.46	150.6

## 5.2 OCCURRENCE

Elements with the higher values of electronegativity usually exist as negative ions, and those with the lower values of electronegativity exist as positive ions. Elements with intermediate values of electronegativity are often found as ions or molecules or in free (elemental) form.

None of the halogens is found in free form in nature. The halogens exist in nature primarily in the form of compounds. Their most common state is the halide ions F<sup>-</sup>, Cl<sup>-</sup>, Br<sup>-</sup> and I<sup>-</sup>. These halides are soluble in water and are found in sea, in salt lakes and as underground beds of salt.

Fluorine		Chlorine	
Fluor spar	CaF <sub>2</sub>	Halite	NaCl
Cryolite	Na <sub>3</sub> AlF <sub>6</sub>	(Salt beds, brine wells, sea water)	
Fluoroapatite	Ca <sub>5</sub> (PO <sub>4</sub> ) <sub>3</sub> F	Carnallite	KCl.MgCl <sub>2</sub> .6H <sub>2</sub> O
Bromine		Iodine	
Brine wells, sea water, NaBr, KBr, MgBr <sub>2</sub> ,		NaIO <sub>3</sub> , NaIO <sub>4</sub> deposits in Chile brine wells.	

### 5.3 PECULIAR BEHAVIOUR OF FLUORINE

The halogens form a homologous series but fluorine differs from the other halogens in many respects which is due to:

- Small size of F atom and of F<sup>-</sup> ion.
- High first ionization energy and electronegativity.
- Low dissociation energy of F<sub>2</sub> molecule as compared to Cl<sub>2</sub> and Br<sub>2</sub>.
- Restriction of the valence shell to an octet.
- Direct combination with inert gases.

Due to the small size of the F atom (or F<sup>-</sup> ion), there will be a better overlap of orbitals and consequently leads to shorter and stronger bonds with elements other than O, N and itself. Ionic fluorides have higher lattice energies than the other halides and these values are responsible for the insolubility of the fluorides of Ca, Mg, Ba, Sr and lanthanides in water. Due to the low dissociation energy of fluorine molecule, it is highly reactive. The other halogens react slowly under similar conditions. The fluorides are, however, more stable with respect to dissociation into elements.

Due to the restriction of valence shell to an octet, many fluoro compounds show inertness, e.g. CF<sub>4</sub> and SF<sub>6</sub>. Also due to this restriction, fluorine remains restricted to -1 oxidation state.

Fluorine is the only element that combines directly with noble gases like Kr, Xe, and Rn forming their fluorides.

### 5.4 OXIDIZING PROPERTIES

#### Relative Reactivities of the Halogens as Oxidizing Agents

All the free halogens act as oxidizing agents when they react with metals or nonmetals. The reactant elements acquire positive oxidation state in the compounds formed.

On forming ionic compounds with metals, the halogens gain electrons and are converted to negative halide ions.



The oxidizing power of halogens decreases with increase in atomic number. Fluorine has the highest oxidizing power and iodine the least. The order of decreasing power as an oxidizing agent is F<sub>2</sub> > Cl<sub>2</sub> > Br<sub>2</sub> > I<sub>2</sub>.

The oxidizing power of halogens depends upon the following factors:

- (i) Energy of dissociation
- (ii) Electron affinity of atoms
- (iii) Hydration energies of ions
- (iv) Heats of vapourization (for Br<sub>2</sub> and I<sub>2</sub>)

If a halogen has a low energy of dissociation, a high electron affinity and a higher hydration energy of its ions, it will have a high oxidizing power.

Oxidizing power of F<sub>2</sub> is higher, because it has low energy of dissociation and higher hydration energy of its ions. Due to the relative strength as oxidizing agents, it is possible for each free halogen to oxidize the ions of other halogens next to it in the family. Standard electrode potential measures oxidizing power.

	F <sub>2</sub>	Cl <sub>2</sub>	Br <sub>2</sub>	I <sub>2</sub>
Standard reduction potential, [E°(V)]	+2.87	+1.36	+1.07	+0.54
X <sub>2</sub> + 2e <sup>-</sup> → 2X <sup>-</sup>				

Fluorine can oxidize all the halide ions to molecular halogens. (A reaction will occur if the value of E° is positive) Iodine being a weak oxidizing agent cannot oxidize chloride or bromide ion.

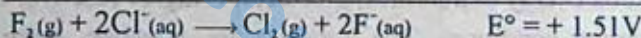
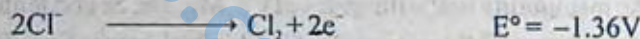

In the similar way, chlorine will oxidize both bromide and iodide ions, while bromine can oxidize only iodide ion.



Fluorine and chlorine can oxidize various coloured dyes to colourless substances, e.g. litmus and universal indicator can be decolourized when exposed to fluorine or chlorine. When used for bleaching, chlorine acts as an oxidizing agent.

## 5.5 COMPOUNDS OF HALOGENS

### 5.5.1 Hydrides (hydrogen halides, HX)

All halogens react with hydrogen forming hydrides. The reaction of molecular hydrogen and fluorine is very fast and explosive. With chlorine, molecular hydrogen reacts in the presence of sunlight. Bromine and iodine react with molecular hydrogen at a higher temperature. The reaction with iodine is very slow and reversible. Direct combination is used as a preparative method only for HCl and HBr. Hydrogen fluoride and hydrogen chloride can also be obtained by the action of concentrated sulphuric acid on fluorides and chlorides, but analogous reactions with bromides and iodides result in partial oxidation of the hydrogen halide to the free halogen.

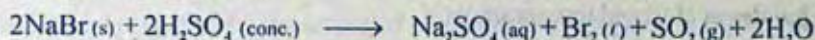

### Properties of Hydrogen Halides

HF is a colourless volatile liquid whereas other hydrogen halides (HCl, HBr, HI) are 'colourless gases at room temperature. They give fumes in moist air. They are strong irritants.

Hydrogen fluoride attacks glass and has found applications as a non-aqueous solvent. It can be handled in teflon (polytetrafluoroethylene) containers or if absolutely dry, in copper or stainless- steel vessels kept under vacuum. Pure liquid HF is strongly hydrogen bonded and is a viscous liquid. Its viscosity is less than that of water due to the absence of a three-dimensional network of H-bonds which occur in H<sub>2</sub>O. Hydrogen bonding is also responsible for the association of HF molecules in the vapour phase. Various test results indicate that gaseous HF consists of an equilibrium mixture of monomers and cyclic hexamers, Fig.5.2.

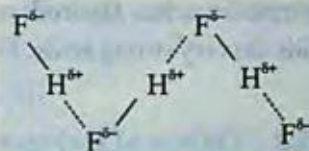
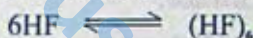

Fig 5.2 Hydrogen bonding in HF



Chain polymers may also exist under certain conditions. Chains and rings of HF are of various sizes, some of these persist in the vapour phase as well. Some of the physical properties of hydrogen halides are given in Table 5.2.

Table 5.2 Some Physical Properties of Hydrogen Halides

Properties	HF	HCl	HBr	HI
Melting points(°C)	-83.8	-114.2	-86.9	-50.8
Boiling points (°C)	19.5	-85.0	-66.7	-35.3
Heat of fusion at M.P. (kJ/mol)	4.58	1.99	2.41	2.87
Heat of vaporization at B.P. (kJ/mol)	30.3	16.2	17.6	19.7
Heat of formation /kJmol <sup>-1</sup> ΔH <sub>f</sub>	-270.0	-92.0	-36.0	+26.0
Bond energy (kJ/mol <sup>-1</sup> )	566	431	366	299
H-X Bond length (pm)	92	128	141	160
Dissociation into elements at 1000°C (%)	0	0.014	0.5	33
Dipole moment (Debye)	1.8	1.1	0.8	0.4

Melting points, boiling points, heats of fusion and heats of vapourization generally increase regularly from HCl to HI. The HF has much higher values for these properties due to hydrogen bonding. A very high boiling point of hydrogen fluoride is a major evidence of the presence of hydrogen bonding among its molecules. The relative volatility of HCl, HBr and HI reflects the strengthening of the van der Waal's forces due to increasing size of halogens. Since the dipole moment of molecules decreases from HCl to HI, probably dipole-induced dipole forces play an important role in the intermolecular binding of the heavier HX molecules.

The strength of the hydrogen halogen bond is very high in HF. It decreases with

increasing size of the halogen atom. The bond strength is reflected in the case of dissociation of hydrogen halides at elevated temperatures.

HF, HCl, HBr and HI act as reducing agents in the following order:



Hydrogen iodide is a strong reducing agent. In redox reactions the hydrogen halides are oxidized to elemental halogens, e.g.



In water, hydrogen halides give hydrofluoric, hydrochloric, hydrobromic and hydroiodic acids. Hydrofluoric acid is a weak acid due to limited ionization. The other three acids are very strong acids. The acidic strength increases in the order:



### 5.5.2 Oxides of Halogens

The halogens do not react directly with oxygen. With the help of some indirect methods, following oxides of group VIIA elements have been made.

Table 5.3 Oxides of Halogens

FLUORINE	CHLORINE	BROMINE	IODINE
Oxygen difluoride, $\text{OF}_2$ Dioxygen difluoride, $\text{O}_2\text{F}_2$ Trioxygen difluoride, $\text{O}_3\text{F}_2$	Dichlorine monoxide, $\text{Cl}_2\text{O}$ Chlorine dioxide, $\text{ClO}_2$ Chlorine hexaoxide, $\text{Cl}_2\text{O}_6$ Chlorine heptaoxide, $\text{Cl}_2\text{O}_7$	Bromine monoxide, $\text{Br}_2\text{O}$ Bromine dioxide, $\text{BrO}_2$ Bromine trioxide, $\text{BrO}_3$ , ( $\text{Br}_2\text{O}_6$ )	Iodine tetraoxide, $\text{I}_4\text{O}_9$ Iodine iodate, $\text{I}_2\text{O}_5$ Iodine pentoxide, $\text{I}_2\text{O}_7$

#### Oxides of Fluorine

##### Tri oxygen Difluoride, $\text{O}_3\text{F}_2$

This oxide can be prepared when a mixture of fluorine and oxygen is subjected to electric discharge. At  $363^\circ\text{C}$ , it is a dark red viscous liquid but turns to reddish brown solid at  $350^\circ\text{C}$ . On decomposition it gives oxygen and other oxide of fluorine.



$\text{O}_3\text{F}_2$  reacts with  $\text{F}_2$  in the presence of electric discharge to produce  $\text{O}_2\text{F}_2$

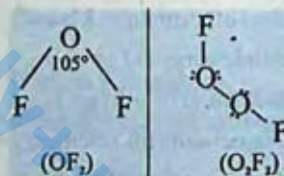
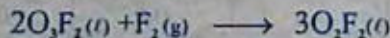

Structure of  $\text{OF}_2$  and  $\text{O}_2\text{F}_2$

#### OXIDES OF CHLORINE

The oxides of chlorine are generally unstable. It is not possible to synthesize them by direct combination of the elements  $\text{Cl}_2$  and  $\text{O}_2$ . They have extensive industrial use as commercial bleaching agents for wood, paper-pulp and for water treatment.

##### 1. Chlorine dioxide, $\text{ClO}_2$

It is a pale yellow gas. It is prepared by reducing  $\text{NaClO}_3$  with  $\text{NaCl}$  or  $\text{SO}_2$  or  $\text{CH}_3\text{OH}$  in strongly acidic solution.



$\text{ClO}_2$  can also be prepared by the action of concentrated  $\text{H}_2\text{SO}_4$  on  $\text{KClO}_3$ . This reaction is violent. To control the reaction oxalic acid should be added.

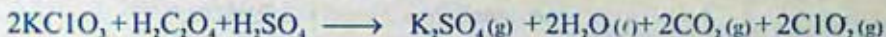

$\text{ClO}_2$  explodes into  $\text{Cl}_2$  and  $\text{O}_2$  on warming. It is soluble in water and is stable in dark. It decomposes slowly in  $\text{H}_2\text{O}$  to  $\text{HCl}$  and  $\text{HClO}_3$ . It is a paramagnetic substance. It is used as an antiseptic, for purification of water and to bleach cellulose material.

## 2. Chlorine Heptaoxide, $\text{Cl}_2\text{O}_7$

$\text{Cl}_2\text{O}_7$  is an anhydride of perchloric acid ( $\text{HClO}_4$ ). It can be obtained at  $-10^\circ\text{C}$  by dehydration of  $\text{HClO}_4$  with  $\text{P}_2\text{O}_5$ .

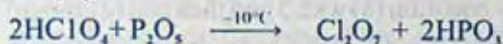

## OXIDES OF BROMINE

Oxides of bromine are dark volatile liquids with low thermal stability.

### Bromine Monoxide $\text{Br}_2\text{O}$

It can be prepared by the reaction of bromine vapours with mercuric oxide.

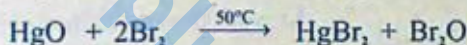

$\text{Br}_2\text{O}$  can also be prepared by treating the suspension of mercuric oxide in  $\text{CCl}_4$  with bromine. It is stable in dark in  $\text{CCl}_4$  at  $-20^\circ\text{C}$ . It has oxidizing properties.

## OXIDES OF IODINE

Out of all the oxides of iodine only iodine pentaoxide ( $\text{I}_2\text{O}_5$ ) is important. The other compounds,  $\text{I}_2\text{O}_4$  and  $\text{I}_2\text{O}_6$ , are salt like and are considered as iodine-iodates.

### Iodine Pentoxide $\text{I}_2\text{O}_5$

It can be prepared by heating iodic acid at  $240^\circ\text{C}$ .

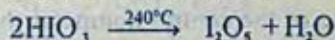

It is a white crystalline solid, stable up to  $300^\circ\text{C}$ . It has a polymeric structure. It is insoluble in organic solvents. It forms iodic acid with water.

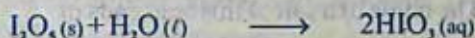

It reacts with  $\text{H}_2\text{S}$ ,  $\text{HCl}$  and  $\text{CO}$  as an oxidizing agent. It is used for the quantitative analysis of  $\text{CO}$ .



## 5.5.3 Reactions of Chlorine with Cold and Hot $\text{NaOH}$

The reactions of chlorine with cold and hot  $\text{NaOH}$  are examples of "Disproportionation reactions".

A reaction in which a species (molecule, atom or ion) is simultaneously oxidized and reduced, is called a "disproportionation reaction".

In cold state  $15^{\circ}\text{C}$  chlorine will react with  $\text{NaOH}$  (aq) to form hypochlorite and a halide.

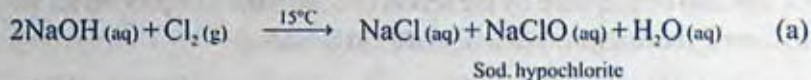

The reaction is a disproportionation reaction, because the zero oxidation state of chlorine atom in  $\text{Cl}_2$  is converted to  $-1$  in chloride and  $+1$  in hypochlorite.

Sodium hypochlorite which is produced in cold state in the above reaction, decomposes forming sodium chloride and sodium chlorate at  $70^{\circ}\text{C}$ .

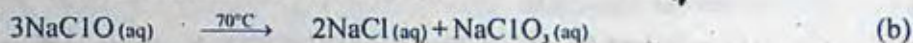

The reaction (b) involves the disproportionation of hypochlorite ion. To balance overall reaction in hot state, multiply equation (a) with 3 and then add (a) and (b).

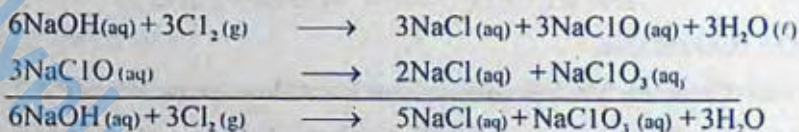

The above two reactions (a) and (b) show that chlorine atoms are both reduced and oxidized.

#### 5.5.4 Oxyacids

An important class of the compounds of the halogens is the oxygen containing acids and their salts.

No oxygen containing stable acid of fluorine is known (HOF is prepared recently, but it is highly unstable). Other halogens form oxyacids though most of them cannot be isolated in pure form and are stable only in aqueous solutions in the form of their salts.

A system of nomenclature for these acids and their salts is based on the oxidation state of the halogen atom. According to this system, characteristic prefixes and suffixes are attached to a stem that is derived from the name of the central nonmetal (halogen) atom. The system is as follows:

1. Some common acid is arbitrarily called the \_\_\_\_\_ic acid (e.g.  $\text{HClO}_3$  is designated as chloric acid). The name of a salt of this acid ends in \_\_\_\_\_ate.
2. An acid whose parent atom has an oxidation state next lower than the \_\_\_\_\_ic acid (one less oxygen atom) is called \_\_\_\_\_ous acid and the name of the salt of this acid ends in \_\_\_\_\_ite. For example, chlorous acid ( $\text{HClO}_2$ ).
3. The acid in which the oxidation state of the parent atom is higher than it is in the \_\_\_\_\_ic acid (one more oxygen atom) is called per \_\_\_\_\_ic acid. A salt of this acid is a per \_\_\_\_\_ate salt. For example, perchloric acid ( $\text{HClO}_4$ ).
4. An acid in which the oxidation state of the parent atom is lower than it is in the \_\_\_\_\_ous acid is called hypo \_\_\_\_\_ous acid and a salt of this acid is a hypo \_\_\_\_\_ite salt.

For example, hypochlorous acid (HClO).

5. The root of the name of the acid or the salt indicates the parent atom.

Table 5.4 shows the oxyacids of halogens (other than fluorine)

Table 5.4 Oxyacids of Halogens

Oxidation state of halogen	Formulae of the oxyacids of halogens			General names of	
	Chlorine	Bromine	Iodine	Oxyacids	Salts of oxyacids
+1	HClO	HBrO	HIO	Hypohalous acid	Hypo__ite
+3	HClO <sub>2</sub>	-----	-----	Halous acid	__ite
+5	HClO <sub>3</sub>	HBrO <sub>3</sub>	HIO <sub>3</sub>	Halic acid	__ate
+7	HClO <sub>4</sub>		HIO <sub>4</sub> , H <sub>5</sub> IO <sub>6</sub>	Perhalic acid	Per__ate

It is evident from the above given formulae of the oxy acids that the halogen serves as a central atom to which one or more oxygen atoms are covalently bonded. These bonds are polar in character due to the electronegativity difference between halogen and oxygen.

The increase in the oxidation state of the halogen from +1 to +7 is accompanied by:

- an increase in the thermal stability of the acid
- the decrease in oxidizing power of the acid
- the increase in acidic strength of the acid

The more the number of oxygen atoms in the series of oxyacids of a halogen, the greater is the thermal stability.

The acid strength increases with the increase in the number of oxygen atoms. As the oxidation state of the halogen increases, the bonding electrons are shifted away from the H-atom and the tendency of the molecule to lose a proton increases. This accounts for the change of strength of oxyacids. The oxyacids of halogens show their strength in the order given below:

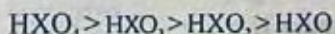

An oxyacid molecule contains hydrogen linked to the halogen through an oxygen atom.

The oxyacids of chlorine are stronger than the corresponding oxyacids of bromine which are, in turn, stronger than the corresponding oxyacids of iodine. It is due to decrease in the electronegativity and increase in the size of the halogen.

We will discuss perchloric acid (HClO<sub>4</sub>) only at this stage.

### PERCHLORIC ACID (HClO<sub>4</sub>)

Perchloric acid (HClO<sub>4</sub>) is commonly obtained in aqueous solution. Pure anhydrous compound can be prepared by distilling a mixture of potassium perchlorate (KClO<sub>4</sub>) and conc. H<sub>2</sub>SO<sub>4</sub> under reduced pressure.

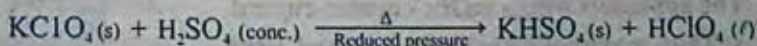

Perchloric acid is a colourless hygroscopic liquid. At normal pressure it freezes at -112°C and boils with decomposition at 90°C.

In the cold and dilute state, perchloric acid is a very weak oxidizing agent but when hot and concentrated its oxidizing power is enhanced. Dissolving power of perchloric acid is enhanced due to its oxidizing strength. Perchloric acid is the strongest of all the acids in an aqueous medium.

Pure perchloric acid decomposes explosively when heated. That is why it is stored and used as 67% solution in water. Perchloric acid reacts with organic substances violently.

Due to its oxidizing effect, acidic strength and solubility of its salts, it is considered as a valuable analytical reagent.

### 5.5.5 Bleaching Powder, (Ca(OCl)Cl)

Bleaching powder can be manufactured by the action of chlorine on dry slaked lime using any one of the following methods:

- Hasenclever's method (old method)
- Beckmann's method (modern method)

The reaction in both the cases will be:

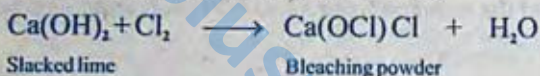

#### (1) Hasenclever's Method

The apparatus used in this method consists of 4 to 8 iron cylinders placed one above the other horizontally. They are interconnected and provided with stirrers. The slaked lime is added in through a hopper in the upper cylinder and is transported from one cylinder to the other with rotating stirrers. Chlorine introduced into the lowest cylinder rises up and reacts with slaked lime to form bleaching powder, which is collected through the outlet in the lowest cylinder.

#### (2) Beckmann's Method

In this method a cast iron tower with eight horizontal shelves is used. In each shelf there is a rotating rake.

'Powdered slaked lime' is introduced through hopper at the top with compressed air. A mixture of hot air and chlorine is introduced from the base of the tower. The slaked lime is pushed down by the rotating rakes while chlorine rises up. Reaction between slaked lime and chlorine produces bleaching powder which is collected at the bottom of the tower, Fig. 5.3.

The apparatus works on the counter-current principle. Thus maximum reaction of slaked lime and chlorine is brought about with very little loss of

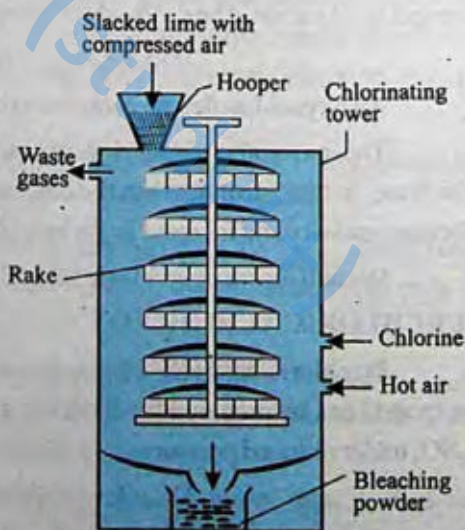
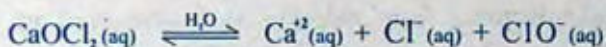

Fig. 5.3 Beckmann's Method

chlorine. Bleaching powder should always be packed in air tight containers to avoid the loss of chlorine.

Bleaching powder is a yellowish white powder with strong smell of chlorine. Some of its chemical properties are given below.

1. It is an oxidizing agent. This property is due to the generation of hypochlorite ion ( $\text{OCl}^-$ ) in water.



2. With dilute acid it gives hypochlorous acid.
 
$$2\text{CaOCl}_2 + \text{dil. H}_2\text{SO}_4(\text{aq}) \longrightarrow \text{Ca}_2\text{SO}_4(\text{aq}) + \text{CaCl}_2(\text{aq}) + 2\text{HClO}(\text{aq})$$
3. If excess of an acid (weak or strong) is added to bleaching powder, chlorine is given out.

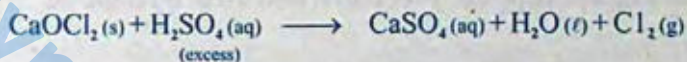

The amount of chlorine thus set free is called "available chlorine". The activity of bleaching powder is measured in terms of available chlorine. The average percentage of available chlorine in bleaching powder is 35-40 percent. The bleaching action of bleaching powder is due to its oxidative character.

4. It oxidizes HCl, HBr and HI giving the corresponding halogens.



5. It oxidizes ammonia to nitrogen

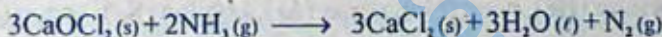

6. Calcium hypochlorite reacts with carbon dioxide to form calcium carbonate and release chlorine.



### Uses

Bleaching powder is used:

- (i) for the laboratory preparation of chlorine and oxygen. It is also used in the manufacture of chloroform.
- (ii) as a disinfectant and in the sterilization of water.
- (iii) for making unshrinkable wool.
- (iv) for bleaching cotton, linen and paper pulp. (Delicate fabrics like wool, silk etc. cannot be bleached with it as these could be damaged by chlorine).

## 5.6 COMMERCIAL USES OF HALOGENS AND THEIR COMPOUNDS

Fluorine is used for the preparation of freons. Freon is the commercial name of low molecular mass fluorochlorocarbons,  $\text{CCl}_2\text{F}_2$ ,  $\text{CClF}_3$ . These are being used as refrigerants and aerosol propellants.

Fluorine is used to prepare Teflon ( $-\text{CF}_2-\text{CF}_2-$ )<sub>n</sub>. It is a polymerized tetrafluoro ethylene compound. It is a valuable plastic

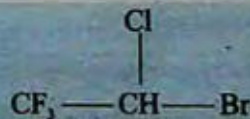

**Halothane**

which resists the action of oxidants, acids and alkalis. Corrosion proof parts of machinery are made of it. It is used for coating the electrical wiring. Teflon is also used as a non-stick coating for cooking pans. Halothane is used as an anaesthetic.

Fluorides in toothpastes build a protective coating on teeth.

Chlorine is used in the manufacture of bleaching powder. It is used as a disinfectant in swimming pools and water treatment plants. A number of antiseptics, insecticides, weedkillers and herbicides are manufactured from chlorine. It is also used in the manufacture of hydrochloric acid, which is the cheapest industrial acid. Chlorine is also used in the manufacture of polyvinyl chloride (PVC) plastics. Chloroform and carbon tetrachloride are prepared from chlorine which are used as solvents.

Ethylene dibromide ( $C_2H_4Br_2$ ) is added to leaded gasoline to save the engine from lead oxide and lead sulphate deposits. Bromine is also used as fungicide. Silver bromide is used in photography.

The major applications of iodine are in pharmaceutical industry. It is used as disinfectant and germicide. Tincture of iodine and iodox are popular preparations of iodine.

Diet with insufficient iodide ions leads to an enlargement of the thyroid (Goiter). To ensure the presence of iodide ion in the diet, sodium or potassium iodide is added to the common salt which is known as iodized salt.

## 5.7 NOBLE GASES

### 5.7.1 Introduction

The elements helium (He), neon (Ne), argon (Ar), krypton (Kr), xenon (Xe) and radon (Rn) are placed in the zero group or group VIIIA of the periodic table. All the elements of this group are colourless and odourless monoatomic gases which can be liquefied and solidified. These are called noble gases or sometime known as rare gases. The noble gases occur as minor constituents of the atmosphere (about 1%). The electronic configurations and some physical properties of noble gases are given in the Table 5.5.

**Table 5.5 Electronic Configurations and Physical Properties of Noble Gases**

Property	He	Ne	Ar	Kr	Xe	Rn
Atomic number	2	10	18	36	54	86
Electronic configurations	$1s^2$	(He) $2s^2 2p^6$	(Ne) $3s^2 3p^6$	(Ar) $3d^{10} 4s^2 4p^6$	(Kr) $4d^{10} 5s^2 5p^6$	(Xe) $5d^{10} 6s^2 6p^6$
Ionization energy ( $\text{kJ mol}^{-1}$ )	2372	2080	1520	1351	1170	1037
Atomic radius (pm)	31	71	98	112	131	140
Melting points ( $^{\circ}\text{C}$ )	-246	-249	-189	-157	-112	-71
Boiling points ( $^{\circ}\text{C}$ )	-269	-246	-186	-153	-108	-62
Water solubility (ml/lit) at $20^{\circ}\text{C}$	13.8	14.7	37.9	73.00	110.9	-
Heat of vapourization ( $\text{kJ mol}^{-1}$ )	0.08	1.77	6.5	9.7	13.7	18.0

The noble gases are isolated from air, either by fractional distillation or by some chemical method. The principal commercial source of Ne, Ar, Kr and Xe is air.

Helium is present on earth as a result of radioactive decay. After hydrogen, it is the second most abundant element in the universe.  $\alpha$ -Particles are doubly ionized helium atoms  $\text{He}^{2+}$ . It is simple and economical to isolate the helium gas from certain natural gases by liquefaction method.

Argon is a colourless and odourless gas. It is very inert and not known to form any true chemical compound. It is obtained as a by-product during the liquefaction of air.

Neon is  $1/65000^{\text{th}}$  part of the atmosphere and it is also isolated during liquefaction of air. In a discharge tube, neon glows reddish (of all the noble gases, the discharge of neon is the most intense at ordinary voltage and current). Liquid neon has over 40 times more refrigeration capacity than liquid helium.

Traces of krypton are present in air. It is a colourless, odourless and fairly expensive gas. It is characterized by its brilliant green and orange spectral lines. Its compound krypton difluoride ( $\text{KrF}_2$ ) can be prepared by various methods.

Xenon is present in the atmosphere to a very small extent (0.08 ppm). It is obtained as a by-product during the fractional liquefaction of air. Xenon is available commercially in cylinders at high pressure. It reacts with fluorine but not with water. However it is slightly soluble in water to the extent of about 110 ml/lit at  $20^\circ\text{C}$ .

Radon is the  $\alpha$ -decay product of the radium. Radon is present to a very small extent in the atmosphere and it could be obtained as a by-product from the liquefaction of air. However, the small quantities of this gas which are usually needed can be collected from the radioactive decay of radium isotopes.



The noble gases have valence shells which are complete octets (except He). Due to complete shells their ionization energy values are very high. They have low boiling points. The boiling point of helium is the lowest of any known substance. Their boiling points increase with increasing atomic number down the group.

The very low values of melting and boiling points and low heats of vapourization show that noble gases have weak forces of attraction between their atoms. As there are no ordinary electron pair interaction, these weak forces must be of the van der Waals' type.

The solubility of the noble gases in water increases with increasing atomic number. This is because the bigger atoms are more readily polarized by water molecules.

### 5.7.2 Compounds of Xenon

Xenon reacts directly with fluorine only. The known oxidation state of Xenon in its compounds ranges from +2 to +8. These compounds are stable and can be obtained in large quantities. Some important compounds of Xenon are given in the Table 5.6.

Table 5.6 Compounds of Xenon

Oxidation state	Compound	Physical form	Melting Point (°C)
+2	XeF <sub>2</sub>	Colourless crystals	140
+4	XeF <sub>4</sub>	Colourless crystals	114
+4	XeOF <sub>2</sub>	Colourless crystals	90
+6	XeF <sub>6</sub>	Colourless crystals	48
+6	XeOF <sub>4</sub>	Colourless liquid	-28
+6	XeO <sub>3</sub>	Colourless crystals	25 (Explodes)
+8	XeO <sub>4</sub>	Colourless gas	-39.9 (Explodes, on warming)

### 5.7.3 Fluorides of Xenon

Three known fluorides of Xenon are XeF<sub>2</sub>, XeF<sub>4</sub> and XeF<sub>6</sub>.

XeF<sub>2</sub> can be prepared by direct interaction of the elements. The compound formed should be removed immediately from the reaction zone, otherwise further reaction with F<sub>2</sub> will give XeF<sub>4</sub>. The reaction is completed in about 8 hours. XeF<sub>2</sub> is a crystalline solid. It is stored in nickel vessels. XeF<sub>2</sub> is a mild fluorinating agent.

XeF<sub>4</sub> can be prepared by heating a mixture of Xe and F<sub>2</sub> in 1:5 ratio in a nickel container under 6 atmospheric pressure for a few hours. It can be stored in nickel vessels. Its properties are similar to that of XeF<sub>2</sub> but it is a strong fluorinating agent.

XeF<sub>6</sub> requires more severe conditions. Xe and F<sub>2</sub> are taken in 3:20 ratio in a stainless steel vessel and heated to 300°C at 50 atmospheric pressure. More than 95% conversion to XeF<sub>6</sub> takes place. XeF<sub>6</sub> is a crystalline solid. It is colourless in the solid state but yellow in liquid and gaseous forms.

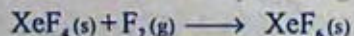

#### Chemical Reactions

Fluorides of xenon can be reduced with hydrogen at 400°C, giving xenon and hydrofluoric acid.

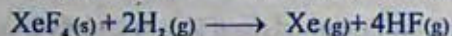

Xenon tetra-fluoride is a good fluorinating agent and can be used to prepare metal fluorides as follows:



Reaction occurs with explosion when XeF<sub>4</sub> is brought in contact with liquid ammonia.



Hydrolysis of XeF<sub>6</sub> with small amount of water gives XeOF<sub>4</sub>,



### 5.7.4 Xenon Oxyfluorides

Xenon oxytetrafluoride,  $\text{XeOF}_4$ , is also formed by a rapid reaction of  $\text{XeF}_6$  with silica (quartz).



$\text{XeOF}_4$  is a colourless volatile liquid. It can be kept in nickel vessel. It reacts with water to give  $\text{XeO}_3$ .



Xenon oxydifluoride,  $\text{XeOF}_2$ , is obtained when xenon reacts with oxygen difluoride in an electric discharge.



### 5.7.5 Oxides of Xenon

There are two oxides of xenon

1. Xenon trioxide
2. Xenon tetraoxide

#### 1. Xenon Trioxide $\text{XeO}_3$

Xenon trioxide can be obtained when  $\text{XeF}_6$  is hydrolysed slowly.



It is a crystalline solid. It explodes at very low temperature. It is weakly acidic and its aqueous solution is almost non-conductor.

#### 2. Xenon Tetraoxide $\text{XeO}_4$

It is obtained by the addition of barium or sodium perxenate to conc.  $\text{H}_2\text{SO}_4$

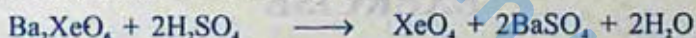

### 5.7.6 Applications of the Noble Gases

1. Helium is used in weather balloons, in welding and in traffic signal lights.
2. A mixture of 80% helium and 20% oxygen is used for breathing by the sea divers.
3. Helium is used as a cooling medium for nuclear reactors.
4. Neon is largely used in making neon advertising signs, in high voltage indicators and TV tubes.
5. Neon and helium arc is used in making glass lasers.
6. Argon is used in electric light bulbs, in fluorescent tubes, in radio tubes, and in Geiger counters (used to detect radioactivity).
7. Argon is also used for arc welding and cutting.
8. Krypton is used to fill fluorescent tubes and in flash lamps for high speed photography.
9. Xenon is used in bactericidal lamps.
10. Radon being radioactive is used in radiotherapy for cancer and for earth quake prediction.

## KEY POINTS

- The halogens are very reactive. Intermolecular forces in halogens increase down the group, fluorine is a gas but iodine is solid.
- They form ionic compounds with s-block metals, covalent compounds with p-block elements and complex ions with d-block metals. Fluorides are usually ionic.
- They show oxidation states -1, +1, +3, +5, +7 but fluorine shows the oxidation state of -1 only.
- Oxidizing power of halogens decreases down the group in the following order:  

$$F_2 > Cl_2 > Br_2 > I_2$$
- Reducing power of halide ions decreases from  $I^-$  to  $Br^-$ . Chloride and fluoride ions are not reductants.
- Chlorine, bromine and iodine form their respective oxides and oxyacids.
- Halogens and their compounds are used for bleaching, refrigeration and as aerosols, etc.
- Noble gases are placed in zero (VIII A) group of periodic table.
- They have valence shells which are closed octets (except helium).
- Very low values of melting and boiling points show that there are very weak forces of attraction between their atoms.
- Oxides, fluorides and oxyfluorides of xenon can be prepared.
- Noble gases have multi-dimensional uses.

## EXERCISE

Q.1 Fill in the blanks.

- The halogen with the highest electronegativity is \_\_\_\_\_.
- HI is \_\_\_\_\_ agent.
- The only halogen acid which is not a strong acid is \_\_\_\_\_.
- Tincture of \_\_\_\_\_ is a common antiseptic.
- The halogen with the lowest melting and boiling points is \_\_\_\_\_.
- Bleaching powder is prepared from \_\_\_\_\_ and \_\_\_\_\_.
- \_\_\_\_\_ is the halogen which causes burns on the skin which heal slowly.
- \_\_\_\_\_ is used for making unshrinkable wool.
- A mixture of \_\_\_\_\_ and \_\_\_\_\_ is used for breathing by the sea divers.
- Noble gas used to fill fluorescent tubes is \_\_\_\_\_.

Q.2 Indicate True or False.

- HF is used for etching glass.
- HI is weaker reducing agent as compared to HF.

- (iii) Bleaching powder is completely soluble in water.
- (iv) The formula of perchloric acid is  $\text{HClO}_4$ .
- (v) On warming, aqueous  $\text{KOC1}$  disproportionates as follows.  
$$3\text{KOC1} \rightarrow 2\text{KCl} + \text{KClO}_3$$
- (vi)  $\alpha$ -particles emitted by radioactive elements are ions of radon.
- (vii) Radon is the only one of the noble gases that is radioactive.
- (viii) The molecules of the noble gases are all monoatomic.
- (ix) Argon is used to fill electric bulbs.
- (x) The noble gas which is present in the largest amount in atmosphere is krypton.

Q 3. Multiple choice questions. Encircle the correct answer.

- (i) Which of the following hydrogen halide is the weakest acid in solution?  
(a) HF (b) HBr (c) HI (d) HCl
- (ii) Chlorine heptaoxide ( $\text{Cl}_2\text{O}_7$ ) reacts with water to form:  
(a) Hypochlorous acid (b) Chloric acid  
(c) Perchloric acid (d) Chlorine and oxygen
- (iii) Hydrogen bond is the strongest between the molecules of:  
(a) HF (b) HCl (c) HBr (d) HI
- (iv) Which halogen will react spontaneously with  $\text{Au(s)}$  to produce  $\text{Au}^{3+}$ ?  
(a)  $\text{Br}_2$  (b)  $\text{F}_2$  (c)  $\text{I}_2$  (d)  $\text{Cl}_2$
- (v) The anhydride of  $\text{HClO}_4$  is:  
(a)  $\text{ClO}_3$  (b)  $\text{ClO}_2$  (c)  $\text{Cl}_2\text{O}_5$  (d)  $\text{Cl}_2\text{O}_7$
- (vi) Bleaching powder may be produced by passing chlorine over:  
(a) calcium carbonate (b) hydrated calcium sulphate  
(c) anhydrous calcium sulphate (d) calcium hydroxide  
(e) magnesium hydroxide
- (vii) Which is the strongest acid?  
(a)  $\text{HClO}$  (b)  $\text{HClO}_2$  (c)  $\text{HClO}_3$  (d)  $\text{HClO}_4$
- (viii) Which halogen occurs naturally in a positive oxidation state?  
(a) Fluorine (b) Chlorine (c) Bromine (d) Iodine
- (ix) An element that has a high ionization energy and tends to be chemically inactive would most likely to be:  
(a) an alkali metal (b) a transition element  
(c) a noble gas (d) a halogen
- (x) Which of the following represents the correct electronic configuration of the

outermost energy level of an element of zero (VIIIA) group in the ground state.

- (a)  $s^2p^2$  (b)  $s^2p^4$  (c)  $s^2p^5$  (d)  $s^2p^6$

- Q.4 What is bleaching powder? How is it prepared commercially? Give its uses.
- Q.5 (a) Discuss the oxides of chlorine.  
(b) What are disproportionation reactions? Explain your answer with an example.
- Q.6 Discuss the system of nomenclature used for oxyacid of halogens. Support your answer with examples.
- Q.7 (a) How the halogen acids are ionized in water?  
(b) Why HF is weaker acid than HCl?
- Q.8 In the following sets, arrange the substances in order of the property indicated. Give reasons.  
(a) Increasing acidic character  
 $\text{HClO}$ ,  $\text{HClO}_2$ ,  $\text{HClO}_3$ ,  $\text{HClO}_4$   
(b) Increasing oxidizing power  $\text{F}_2$ ,  $\text{Cl}_2$ ,  $\text{Br}_2$ ,  $\text{I}_2$ .
- Q.9 What happens when bleaching powder reacts with the following reagents dil.  $\text{H}_2\text{SO}_4$ , excess of cone.  $\text{H}_2\text{SO}_4$ ,  $\text{NH}_3$ , HI and  $\text{CO}_2$ .
- Q.10 Discuss the various commercial uses of halogens and their compounds.
- Q.11 What are noble gases? Explain their inertness on the basis of their electronic configuration.
- Q.12 Write notes on the followings.  
(i) Oxyfluorides of xenon.  
(ii) Applications of noble gases.
- Q.13 Short questions.  
(i) What is "Iodized Salt"?  
(ii) What are Freons and Teflon?  
(iii) Arrange the following ions in order of increasing size:  
 $\text{F}^-$ ,  $\text{Cl}^-$ ,  $\text{I}^-$ ,  $\text{Br}^-$   
(iv) Why iodine has metallic luster?  
(v) Which halogen sublimes to violet vapours?  
(vi) Which halogen is used as an antiseptic?  
(vii) Which halogen is used in water treatment to kill bacteria?  
(viii) Name the gas, which is used for earthquake prediction.  
(ix) Name the gas, which is used in bactericidal lamps.

## CHAPTER

## 6

## TRANSITION ELEMENTS

## In this chapter you will learn

1. The definition and classification of transition elements.
2. The electronic configurations and the general characteristics like colour binding energies, etc.
3. The definition of a complex compound and the related terms like ligand, coordination number, etc.
4. The nomenclature and the geometrical shapes of simple complex compounds.
5. A brief description of the manufacture of wrought iron and steel from iron ore.
6. How corrosion is caused and the ways to prevent it.
7. The important methods of preparation of potassium chromate, potassium dichromate, potassium permanganate and their properties.

## 6.1 INTRODUCTION

Transition elements may be defined as those elements which have partially filled d or f-subshells in atomic state or in any of their commonly occurring oxidation states.

The d-block and the f-block elements are called transition elements because they are located between the s and p-block elements and their properties are in transition between the metallic elements of the s-block and nonmetallic elements of the p-block.

The electronic configurations of three series of d-block elements are given in Table 6.1.

The detailed electronic configurations of the valence shell of the first transition series is shown in Table 6.2. You will notice that in chromium one electron from s-subshell has been used to half fill d-subshell. Similarly, in copper, one electron from s-subshell has gone to d-subshell to fill it completely. This appears to be due to a certain measure of stability associated with a half filled  $d^5$  shell and a full  $d^{10}$  shell.

Table 6.1 Electronic configurations of three series of d-block elements

3d-block elements		4d-block elements		5d-block elements	
Elements	Electronic configuration	Elements	Electronic configuration	Elements	Electronic configuration
Sc (21)	[Ar] 3d <sup>1</sup> 4s <sup>2</sup>	Y (39)	[Kr]4d <sup>1</sup> 5s <sup>2</sup>	La (57)	[Xe] 5d <sup>1</sup> 6s <sup>2</sup>
Ti (22)	[Ar] 3d <sup>2</sup> 4s <sup>2</sup>	Zr (40)	[Kr]4d <sup>2</sup> 5s <sup>2</sup>	Hf (72)	[Xe] 4f <sup>14</sup> 5d <sup>2</sup> 6s <sup>2</sup>
V (23)	[Ar] 3d <sup>3</sup> 4s <sup>2</sup>	Nb (41)	[Kr]4d <sup>4</sup> 5s <sup>1</sup>	Ta (73)	[Xe] 4f <sup>14</sup> 5d <sup>3</sup> 6s <sup>2</sup>
Cr (24)	[Ar] 3d <sup>5</sup> 4s <sup>1</sup>	Mo (42)	[Kr]4d <sup>5</sup> 5s <sup>1</sup>	W (74)	[Xe] 4f <sup>14</sup> 5d <sup>4</sup> 6s <sup>2</sup>
Mn (25)	[Ar] 3d <sup>5</sup> 4s <sup>2</sup>	Tc (43)	[Kr]4d <sup>5</sup> 5s <sup>2</sup>	Re (75)	[Xe] 4f <sup>14</sup> 5d <sup>5</sup> 6s <sup>2</sup>
Fe (26)	[Ar] 3d <sup>6</sup> 4s <sup>2</sup>	Ru (44)	[Kr]4d <sup>7</sup> 5s <sup>1</sup>	Os (76)	[Xe] 4f <sup>14</sup> 5d <sup>6</sup> 6s <sup>2</sup>
Co (27)	[Ar] 3d <sup>7</sup> 4s <sup>2</sup>	Rh (45)	[Kr]4d <sup>8</sup> 5s <sup>1</sup>	Ir (77)	[Xe] 4f <sup>14</sup> 5d <sup>7</sup> 6s <sup>2</sup>
Ni (28)	[Ar] 3d <sup>8</sup> 4s <sup>2</sup>	Pd (46)	[Kr]4d <sup>10</sup>	Pt (78)	[Xe] 4f <sup>14</sup> 5d <sup>9</sup> 6s <sup>1</sup>
Cu (29)	[Ar] 3d <sup>10</sup> 4s <sup>1</sup>	Ag (47)	[Kr]4d <sup>10</sup> 5s <sup>1</sup>	Au (79)	[Xe] 4f <sup>14</sup> 5d <sup>10</sup> 6s <sup>1</sup>
Zn (30)	[Ar] 3d <sup>10</sup> 4s <sup>2</sup>	Cd (48)	[Kr]4d <sup>10</sup> 5s <sup>2</sup>	Hg (80)	[Xe] 4f <sup>14</sup> 5d <sup>10</sup> 6s <sup>2</sup>

### 6.1.1 Typical and Non-Typical Transition Elements

Group IIB elements (Zn, Cd and Hg) do not have a partially filled d-subshell either as elements or in any of their ionic state. Neither do they show typical properties of transition elements to any appreciable extent (except complex formation). Similarly, IIIB (Sc, Y and La) is another group of elements which do not show many of the properties associated with typical transition elements. They are transition elements by definition, as there is one electron in the d-subshell of each atom. In compounds they mostly occur as the tripositive ions, having no d-electron (the atom having lost its only one d-electron), hence they do not exhibit properties

Table 6.2 Detailed electronic configurations of the valence shell of first series of transition Elements

	3d					4s
Sc (Ar)	↑					↑↓
Ti (Ar)	↑	↑				↑↓
V (Ar)	↑	↑	↑			↑↓
Cr (Ar)	↑	↑	↑	↑	↑	↑
Mn (Ar)	↑	↑	↑	↑	↑	↑↓
Fe (Ar)	↑↓	↑	↑	↑	↑	↑↓
Co (Ar)	↑↓	↑↓	↑	↑	↑	↑↓
Ni (Ar)	↑↓	↑↓	↑↓	↑	↑	↑↓
Cu (Ar)	↑↓	↑↓	↑↓	↑↓	↑↓	↑
Zn (Ar)	↑↓	↑↓	↑↓	↑↓	↑↓	↑↓

of transition elements and behave like main group elements. In order to maintain a rational classification, the elements of group IIB and group IIIB are referred to as **non-typical transition elements** and the elements in the remaining transition series are called **typical transition elements**, Table 6.3.

We treat the coinage metals Cu, Ag and Au as transition metals, since Cu<sup>2+</sup> has a 3d<sup>9</sup>



configuration,  $\text{Ag}^{2+}$  a  $4d^9$  and  $\text{Au}^{3+}$  a  $5d^8$  configuration.

f-Block elements, i.e., Lanthanides and Actinides are also called **inner transition metals**, whereas d-block elements are called **outer transition metals**.

## 6.2 PROPERTIES OF TRANSITION ELEMENTS

Because of a similar electronic configuration, the d-block elements closely resemble one another in their physical and chemical properties.

Some of the points of their resemblance are given below.

1. They are all metals in true sense, some of which play important role in industry, e.g. Ti, Fe, Cr, Ni, Cu, Mo, W, Zr, Nb, Ta, Th, etc.
2. They are all hard and strong metals with high melting and boiling points. They are also good conductors of heat and electricity.
3. They form alloys with one another and also with other elements.
4. With few exceptions, they show variable valency or oxidation state.
5. Their ions and compounds are coloured in solid state as well as in solution form at least in one if not all the oxidation states.

### 6.2.1 General characteristics

#### (a) Binding energies

Transition metals show good mechanical properties. They are tough, malleable and ductile. The toughness of these metals indicates strong metallic binding. This is because, apart from s-electrons of the outer most shell, the electrons of underlying half-filled d-orbitals also participate in binding.

In moving from left to right in any transition series, the number of unpaired electrons increases up to groups VB and VIB, after that pairing takes place and number of unpaired electrons goes on decreasing until it becomes zero at group IIB, Table 6.3.

Therefore, binding is stronger upto group VIB and weakens progressively upto group IIB. This trend of variation in binding energies is shown in Fig. 6.1. In the first transition series the general increase in binding energy ends at vanadium. This is due to changes in metallic structure, e.g. Mn. In the third transition series, the increase in binding energy ends at tungsten when all the 5d electrons contribute to binding.

#### (b) Melting and Boiling Points

Transition metals have very high melting and boiling points due to strong binding forces present between their atoms. Melting points increase up to the middle of the series and then

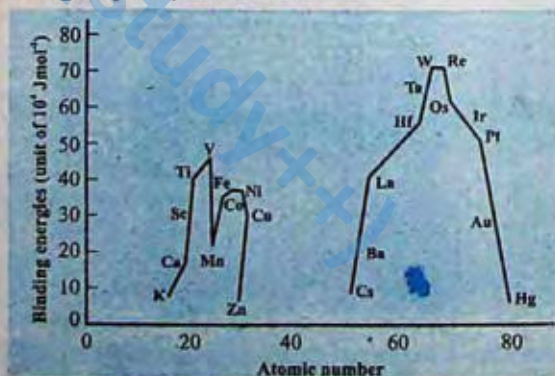

Table 6.1 Binding energies of the elements of the first and third transition series

decrease to a minimum level at the end of the series.

This trend in melting points correlates well with the strength of binding forces as is clear from the Figs. 6.1 and 6.2.

### c) Covalent Radii and Ionic Radii

The covalent radii decrease rapidly at the start of the series, then become almost constant and finally begin to increase at the end of the series. The increase in covalent radii is possibly due to the fact that the filled 3d orbitals have contracted into the electron core and so shield the outer 4s electrons more effectively from the nucleus, Fig. 6.3.

Changes in the ionic radii along the series are much less regular, so that periodic trends in the properties of these ions are difficult to rationalize.

### (d) Paramagnetism

Substances which are weakly attracted by a strong magnetic field are called **paramagnetic substances**. Those substances which are weakly repelled by a strong magnetic field are called **diamagnetic substances**.

Paramagnetic behaviour is caused by the presence of unpaired electrons in an atom, molecule or ion because there is a magnetic moment associated with the spinning electron. It increases with increase in the number of unpaired electrons.

When the electrons are paired in an orbital, then magnetic moments are cancelled out and the substances become diamagnetic.

The paramagnetic behaviour is the strongest for  $\text{Fe}^{3+}$  and  $\text{Mn}^{2+}$  and decreases on both sides of the first transition series. The

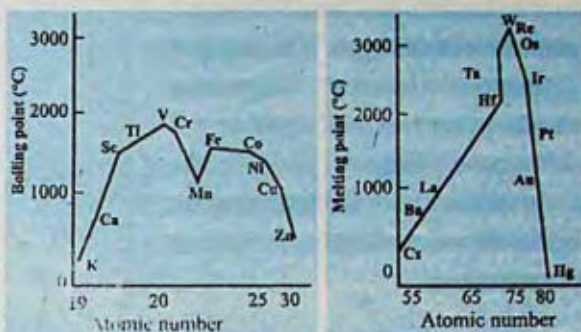

Fig. 6.2 Melting points of the elements of the first and the third transition series

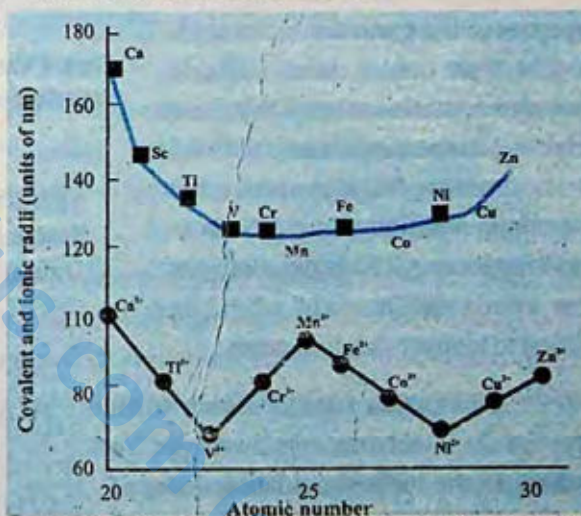

Fig. 6.3 Covalent radii (—•) and ionic radii (---■) of first transition series elements

Table 6.4 No. of Unpaired electrons in the First Series of Transition Elements

Ion	3d orbital electronic structure					No. of unpaired electron
$\text{Sc}^{3+}$						0
$\text{Ti}^{3+}$	↑					1
$\text{V}^{3+}$	↑	↑				2
$\text{Cr}^{3+}$	↑	↑	↑			3
$\text{Mn}^{2+}$	↑	↑	↑	↑	↑	4
$\text{Mn}^{2+}, \text{Fe}^{3+}$	↑	↑	↑	↑	↑	5
$\text{Fe}^{2+}$	↑↓	↑	↑	↑	↑	4
$\text{Co}^{2+}$	↑↓	↑↓	↑	↑	↑	3
$\text{Ni}^{2+}$	↑↓	↑↓	↑↓	↑	↑	2
$\text{Cu}^{2+}$	↑↓	↑↓	↑↓	↑↓	↑	1
$\text{Zn}^{2+}$	↑↓	↑↓	↑↓	↑↓	↑↓	0

reason is that both  $\text{Mn}^{2+}$  and  $\text{Fe}^{3+}$  have 5 unpaired electrons each. The number of unpaired electrons decreases gradually to zero on both sides, as it is clear from the Table 6.4. Fig. 6.4 shows the variation in the paramagnetic effect of the ions belonging to the first transition series.

### (e) Oxidation State

One of the most important properties of the transition elements is the fact that they exhibit variable valency or oxidation state. They show variable valencies because of the involvement of the unpaired d electrons in addition to s electrons in bond formation. All 3d series elements show an oxidation state of +2 in addition to higher oxidation states.

+2 oxidation state is shown when only the 2s electrons are involved in bonding. In the highest oxidation states of the first five elements all the s and d electrons are used for bonding. After Mn, the number of oxidation states decreases as the d-subshells fill up and fewer unpaired electrons are available for bond formation as shown in Table 6.5.

### (f) Colour

In transition elements, the d orbitals are responsible for the colour development in their compounds. When these orbitals are involved in bonding, they split up into two energy levels, one set has a higher energy than the other. The electrons residing in low energy d-orbitals absorb a part of the visible light and jump to high energy d orbitals. The process is called d-d transition, Fig. 6.5. The energy difference of d-orbitals varies from ion to ion. Thus, every ion absorbs a different wavelength and transmits the remaining set of wavelengths that gives different colours to the ions.

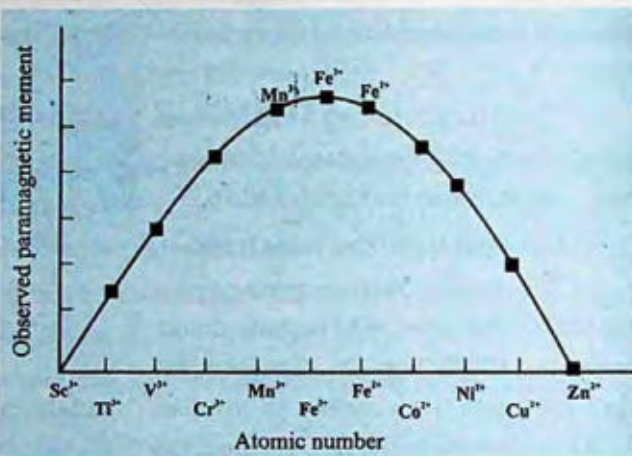

Fig 6.4 Variation in the paramagnetic effect shown by the selected ions across the first transition series

Table 6.5 Commonly Occurring Oxidation States of the 1st Series of Transition Elements  
Oxidation states

	Oxidation states						
	2	3	4	5	6	7	
Sc(Ar) 3d <sup>1</sup> 4s <sup>2</sup>	2	3					
Ti(Ar) 3d <sup>2</sup> 4s <sup>2</sup>	2	3	4				
V(Ar) 3d <sup>3</sup> 4s <sup>2</sup>	2	3	4	5			
Cr(Ar) 3d <sup>5</sup> 4s <sup>1</sup>	2	3	4	5	6		
Mn(Ar) 3d <sup>5</sup> 4s <sup>2</sup>	1	2	3	4	5	6	7
Fe(Ar) 3d <sup>6</sup> 4s <sup>2</sup>	1	2	3	4	5	6	
Co(Ar) 3d <sup>7</sup> 4s <sup>2</sup>	2	3	4	5			
Ni(Ar) 3d <sup>8</sup> 4s <sup>2</sup>	2	3	4				
Cu(Ar) 3d <sup>10</sup> 4s <sup>1</sup>	1	2	3				
Zn(Ar) 3d <sup>10</sup> 4s <sup>2</sup>	2						

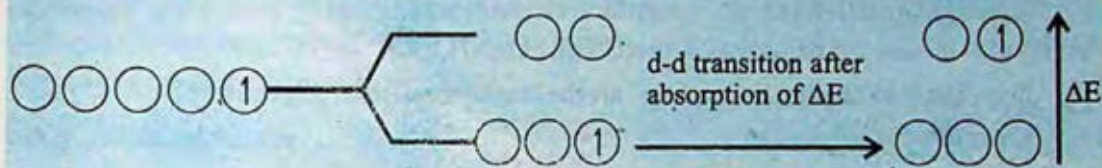

Fig. 6.5 Absorption of yellow light by  $[\text{Ti}(\text{H}_2\text{O})_6]^{3+}$  ion.

In  $[\text{Ti}(\text{H}_2\text{O})_6]^{3+}$ , yellow light is absorbed, while most of the blue and red lights are transmitted, therefore the solution of  $[\text{Ti}(\text{H}_2\text{O})_6]^{3+}$  ions looks violet in colour.

### (g) Interstitial Compounds

When small non-metal atoms like H, B, C, N enter the interstices of transition metals and impart useful features to them, they are called **Interstitial compounds**. These are non-stoichiometric compounds. Sometime they are also termed as interstitial alloys.

### (h) Alloy Formation

Owing to the similarity in their sizes, some transition metal atoms are able to replace one another in the metallic lattice and form **substitutional alloys** among themselves. Alloy steels are an important example of this type of material in which iron atoms are substituted by chromium, manganese and nickel atoms, etc. to give the steel more useful properties. Other examples are brass, bronze, coinage alloys, etc.

## 6.3 COMPLEX COMPOUNDS

It has been observed that when the aqueous solutions of  $\text{Fe}(\text{CN})_2$  and KCN are mixed together and evaporated, a new compound is obtained, which in aqueous solution does not ionize as  $\text{Fe}^{2+}$  and  $\text{CN}^-$  ions but ionizes as  $\text{K}^+$  ion and  $[\text{Fe}(\text{CN})_6]^{4-}$  ion (Ferrocyanide ion). On this basis it has been given a formula  $\text{K}_4[\text{Fe}(\text{CN})_6]$ .

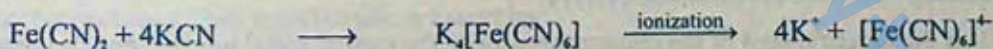

Here  $[\text{Fe}(\text{CN})_6]^{4-}$  is called a complex ion.

Such compounds containing the complex molecules or complex ions and capable of independent existence are called coordination compounds or complexes.

A complex compound may contain

1. a simple cation and a complex anion
2. a complex cation and a simple anion

### 6.3.1 Components of Complex Compounds

It is necessary to understand different terms used in the study of the complex compounds. These are as follows:

**(a) Central Metal Ion**

A metal atom or ion (usually a transition element) surrounded by a number of ligands is called a central metal atom or ion, e.g.  $K_4[Fe(CN)_6]$ ,  $[Ag(NH_3)_2]Cl$ .

In the above examples,  $Fe^{2+}$  and  $Ag^+$  are the central metal ions, respectively.

**(b) Ligand**

The atoms or ions or neutral molecules, which surround the central metal ion and donate electron pairs to it, are called ligands. They may be anions or neutral molecules, e.g.  $K_4[Fe(CN)_6]$ ,  $[Ag(NH_3)_2]Cl$ .

In the above examples,  $CN^-$  and  $NH_3$  are the anionic and neutral ligands, respectively.

Ligands having two donor atoms are called bidentate ligands, e.g.

Oxalate ion  $\begin{array}{c} COO^- \\ | \\ COO^- \end{array}$  is a bidentate ligand and its coordination with the metal ion occurs

through its both negatively charged oxygen atoms.

**(c) Coordination Number**

The number of lone pair of electrons provided by the ligands to the central metal atom or ion is called the coordination number of the central metal atom or ion, e.g.

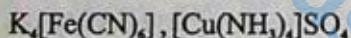

In the above examples, coordination number of iron is 6 and that of copper is 4.

**(d) Coordination Sphere**

The central metal atom or ion alongwith ligands is called the coordination sphere. It is usually placed in square brackets. It may be anionic, cationic or neutral, e.g.

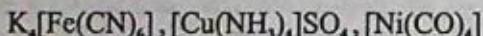

In the above examples,  $[Fe(CN)_6]^{4-}$ ,  $[Cu(NH_3)_4]^{2+}$  and  $[Ni(CO)_4]^0$  are anionic, cationic and neutral coordination spheres, respectively.

**(e) Charge on the Coordination Sphere**

It is the algebraic sum of the charges present on the central metal ion and the total charge on the ligands, e.g;

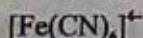

Charge on iron  $= +2$

Total charge on six  $CN^-$  ions  $= -6$

Charge on the coordination sphere  $= -6 + 2 = -4$

**6.3.2 Chelates**

When all the donor atoms of a polydentate ligand get coordinated with the same metal ion, a complex compound is formed which contains one or more rings in its structure and hence is called a **Chelate**. Metal chelates are more stable metal complexes.

When two oxalato ligands  $C_2O_4^{2-}$  (bidentate ligand) get coordinated with  $Pt^{2+}$  ion, dioxalato platinate (II) ion is obtained. Each oxalate ligand forms a five membered ring with the cation.

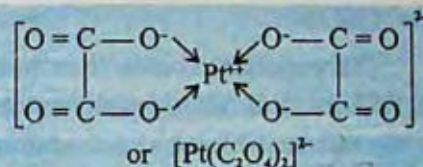

**Dioxalato - platinate (II) ion**

### 6.3.3 Nomenclature

The nomenclature of complex compounds is based upon the recommendations by the Inorganic Nomenclature Committee of IUPAC.

The rules for naming the complex compounds are as follows:

1. Cations are named before anions.
2. In naming the coordination sphere, ligands are named in alphabetical order regardless of the nature and number of each, followed by the name of central metal ion.
3. The prefixes di, tri, tetra, penta, hexa, etc, are used to specify the number of coordinated ligands.
4. The names of anionic ligands end in suffix O, e.g, hydroxo,  $(OH^-)$  carbonato  $(CO_3^{2-})$ .
5. The names of neutral ligands are usually unchanged, e.g. for  $NH_3$ , ammine and for  $H_2O$ , aqua and for CO, carbonyl.
6. The suffix 'ate' comes at the end of the name of metal if the complex represents an anion, otherwise it remains unchanged.
7. The oxidation number of the metal ion is represented by a Roman numeral in parenthesis following the name of the metal.

**Examples:**  $K_4[Fe(CN)_6]$  Potassium hexacyano ferrate (II)  
 $[PtCl(NO_2)(NH_3)_4]SO_4$  Tetraammine chloronitro-platinum (IV) sulphate  
 $[Co(NO_2)_3(NH_3)_3]$  Triammine trinitrocobalt (III)

In writing the formula of a complex ion, the usual practice is to place the symbol of the central metal atom first, followed by the formulas of the anionic ligands in alphabetical order, then neutral ligands in alphabetical order and the formula of the whole complex ion is enclosed in square brackets as is clear from the above examples.

### 6.3.4 Geometry of Complexes

The geometry of complexes depends upon the type of hybridization taking place in the valence shell of the central metal atom.

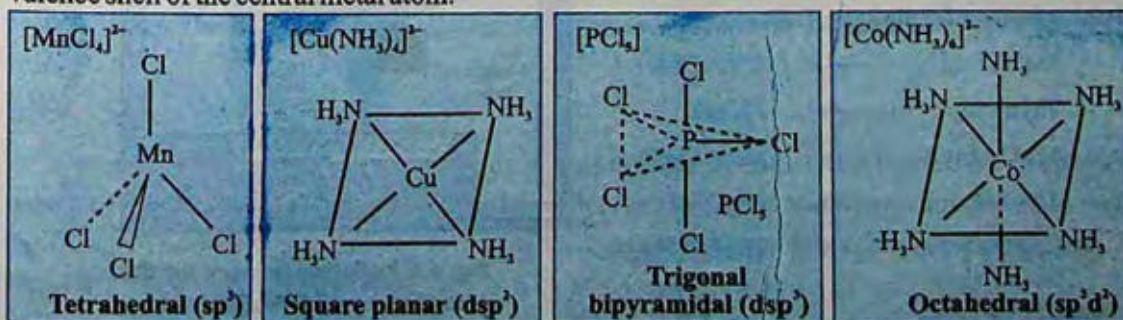

## 6.4 IRON

The important ores of iron are magnetite ( $\text{Fe}_3\text{O}_4$ ), haematite ( $\text{Fe}_2\text{O}_3$ ) and limonite  $\text{Fe}_2\text{O}_3 \cdot 3\text{H}_2\text{O}$  etc. Iron has been known since prehistoric days. It was used in Egypt in 1500 B.C. It is known that the Chinese also used iron as early as 2500 B.C. In the subcontinent, iron was produced around 600 B.C.

### 6.4.1 Commercial Forms of Iron

Iron is available commercially in the following three forms. They differ in carbon contents as follows:

1. Pig iron or cast iron 2.5 to 4.5% carbon
2. Wrought iron 0.12 to 0.25% carbon
3. Steel 0.25 to 2.5% carbon

### 6.4.2 Wrought Iron

#### Composition

It is the purest form of commercial iron and contains the lowest percentage of carbon and upto 0.3% of impurities like S, P, Si and Mn, etc.

$\text{S} = 0.2 \text{ to } 0.15\%$ ,  $\text{Mn} = \text{upto } 0.25\%$ ,  $\text{P} = 0.04 \text{ to } 0.2\%$

### 6.4.3 Manufacture of Wrought Iron from Cast Iron

It is manufactured from cast iron by puddling, i.e., by heating cast iron in a special type of reverberatory furnace called puddling furnace, Fig. 6.6. This furnace has a low roof to deflect the hot gases and flames downwards and to melt cast iron. The hearth of the furnace is lined with haematite ( $\text{Fe}_2\text{O}_3$ ). The cast iron is placed on the hearth, melted by hot gases and stirred or puddled with long iron rods called rabblers through the doors to bring it in thorough contact with the lining of the hearth, i.e.  $\text{Fe}_2\text{O}_3$ .

The haematite ( $\text{Fe}_2\text{O}_3$ ) lining supplies oxygen, necessary for the oxidation of carbon, sulphur, silicon, manganese and phosphorus present in the cast iron. Oxides of carbon and sulphur, being volatile escape out at high temperature.



While those of manganese, silicon and phosphorus form slags. Thus

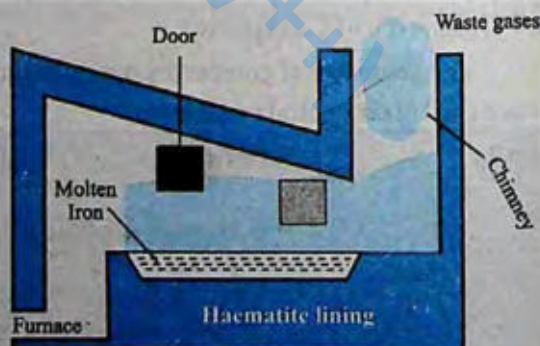

Fig. 6.6 Puddling furnace for the manufacture of wrought iron

With the removal of impurities, the melting point of the metal rises and it becomes a semi-solid mass. At this stage, it is taken out in the form of balls or blooms on the ends of rables. While still hot, these balls are subjected to hammering to squeeze out, as much of slag as possible. The product so obtained is known as wrought iron.

#### 6.4.4 Steel

Steel is an alloy of iron containing 0.25 to 2.5% of carbon and traces of S, P, Si and Mn.

##### Classification of Steel

##### 1. Mild Steel (0.1 - 0.2 % C)

It is fairly soft, malleable and ductile, can be forged (shaped by hammering and pressing while hot). It is used in making tubes, nuts, bolts, bars and boiler plates.

##### 2. Medium Carbon Steel (0.2 - 0.7 % C)

It is harder than mild steel. It is also malleable and ductile. It is used in making rails, axles, castings.

##### 3. High Carbon Steel (0.7 - 1.5 % C)

It is hard and can be forged, when containing less than 1.0% carbon. Steel containing more than 1.0% carbon cannot be forged. It is used to make hammers, taps, dies, cutting tools, machine tools, hard steel parts of machinery and all sort of engines.

Steel is intermediate in carbon content between cast iron and wrought iron. It can be produced from:

- Cast iron by removing some carbon alongwith sulphur, phosphorus and silicon.
- By adding the required amount of carbon to wrought iron, then adding some special constituents, e.g. tungsten, chromium, vanadium, molybdenum, manganese, nickel and cobalt which impart desired properties to the steel. At present most of the steel is manufactured from cast iron.

#### 6.4.5 Manufacture of Steel

It can be manufactured by the following processes.

- Open hearth process** (using cast iron, wrought iron or steel scrap)
- Bessemer's process** (using cast iron only)

Some other processes are also used to prepare special type of steel from pure wrought iron.

#### 6.4.6 Open Hearth Process

This is the most modern method for the manufacture of steel. It is carried out in an open hearth furnace. This furnace has a low roof to deflect the hot gases and flames downward to melt the charge. The open hearth furnace works on the regenerative principle of heat economy Fig.6.7. Open hearth process is of two types.

1. Furnace with acidic lining like  $\text{SiO}_2$  is used when the impurities are Mn, Si, etc.
2. Furnace with basic lining like dolomite ( $\text{CaO}$ ,  $\text{MgO}$ ) is used when the impurities are P and S, etc.

### Process

A mixture of cast iron, scrap steel and quick lime is charged into the furnace. At about  $1600^\circ\text{C}$  Si, Mn, C, S, and P are burnt out and removed according to the following reactions.



CO escapes in the flue gases. Silica ( $\text{SiO}_2$ ) combines with  $\text{CaO}$ ,  $\text{MnO}$  and  $\text{FeO}$  to form silicates (slag) which float on the surface of the molten metal.



Phosphorus and sulphur react with  $\text{Fe}_2\text{O}_3$  to form  $\text{P}_2\text{O}_5$  and  $\text{SO}_2$ .

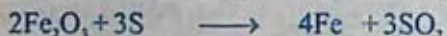

These oxides react with calcium oxide to form slag.



Samples are taken at intervals and the percentage of carbon in the steel is determined regularly. When this is reduced to about 0.1%, the calculated weight of ferromanganese (Fe, Mn, C) is added. Manganese desulphurises the steel. Carbon raises the carbon contents to the required values. After giving time for mixing, a little more ferromanganese is added and the charge is allowed to run into moulds where it solidifies to ingots.

The whole process takes about 10 hours. Slag contains calcium phosphate. It is ground to powder and sold as a fertilizer.

### 6.4.7 Bessemer's Process

The furnace used in this process is called Bessemer's converter which is a pear shaped vessel made of steel plates. At the bottom the converter is provided with a number of holes

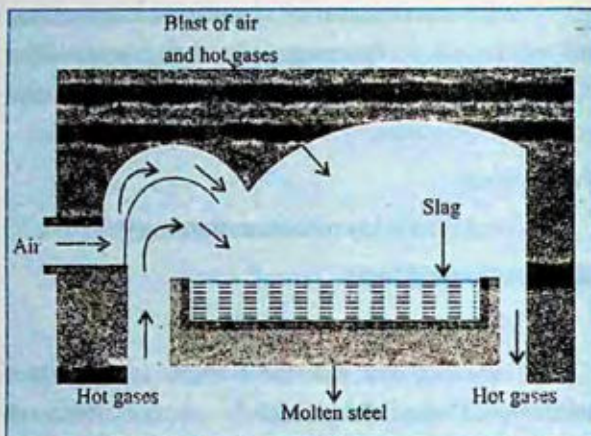

Fig. 6.7 Open Hearth furnace for the manufacture of steel from cast iron

through which hot air can be introduced. The converter is held on a central axis so that it can be tilted in any desired position for feeding and pouring out the finished materials, Fig.6.8.

Molten pig or cast iron (25 to 30 tons) from the blast furnace is fed into the converter and hot air blast is injected through the perforated base. This oxidizes carbon, silicon, and manganese.



These oxides form a slag of  $\text{MnSiO}_3$ . The heat evolved during the oxidation is enough to keep iron in the molten state.



CO produced burns at the mouth of the converter with a blue flame. Iron is partly oxidized to ferric oxide ( $\text{Fe}_2\text{O}_3$ ) which also extracts carbon from cast iron to form CO.



Within 10 to 15 minutes the flame due to CO subsides indicating that the carbon is completely oxidized. At this stage ferromanganese is added to correct the proportion of carbon to obtain the desired qualities. A blast of air is continued for a moment to ensure thorough mixing. The addition of Mn imparts increased hardness and tensile strength.

In order to remove entrapped bubbles of gases (blow holes), such as  $\text{O}_2$ ,  $\text{N}_2$ ,  $\text{CO}_2$ , a little aluminum or ferro-silicon is also added. Aluminum removes nitrogen as nitride.



At the end of the operation, the molten steel is poured out into moulds for casting. Such casting are free from any defect.

## 6.5 CORROSION

Any process of chemical decay of metals due to the action of surrounding medium is called corrosion.

The simplest case of corrosion occurs when metals come into contact with gases of the atmosphere. The surface of metals becomes coated with compounds such as oxides, sulphides and carbonates. Such compounds sometime form a compact layer on the surface protecting the metal from further attack.

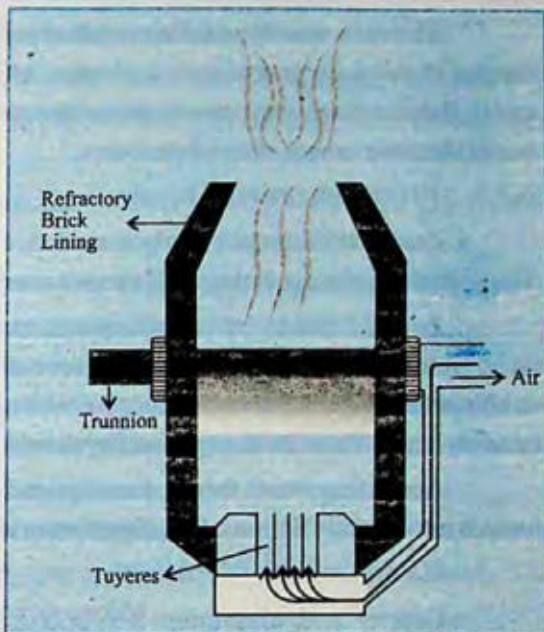

Fig 6.8 Bessemer's converter for the manufacture of steel from cast iron.

The case would be different when the metal is in contact with water. The compounds formed in this case may dissolve in water, allowing the corrosion to penetrate further into the metal. Besides dissolving the compounds, water also promotes electrochemical process which is one of the main causes of rapid corrosion.

### 6.5.1 Electrochemical Theory

Pure metals are not easily corroded, even iron hardly gets corroded if absolutely pure. The impurities present in the metal promote corrosion.

To understand why impurities accelerate the corrosion of metals, consider what happens when two different metals come in contact with one another in moist air. Suppose, Cu is brought in contact with Al. After sometime, we will notice that aluminium gets corroded while copper remains intact. This can be explained by the electrochemical theory.

According to this theory, moisture and  $\text{CO}_2$  are present on the surface of the metal. Water ionizes into  $\text{H}^+$  and  $\text{OH}^-$  ions.  $\text{CO}_2$  dissolves in water forming  $\text{H}_2\text{CO}_3$ , which ionizes as follows:



Copper and aluminium are, in a sense, immersed in the solution containing  $\text{H}^+$ ,  $\text{OH}^-$  and  $\text{HCO}_3^-$  ions. This forms a galvanic cell in which aluminium releases electrons and changes to  $\text{Al}^{3+}$  ion (being more reactive than Cu) i.e. it acts as positive electrode and Cu acts as a negative electrode, Fig.6.9.

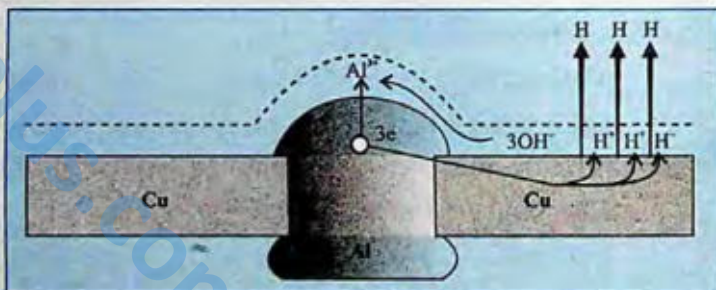

Fig.6.9 Diagram of the corrosion of aluminium in contact with copper

Aluminium ions attract  $\text{OH}^-$  ion to form,  $\text{Al}(\text{OH})_3$ , i.e. it starts dissolving. The  $\text{H}^+$  ions present on the Cu receive the electrons and release as  $\text{H}_2$ . In this way, aluminium corrodes rapidly when in contact with copper which is lower in electrochemical series. From this, we can conclude that when an active metal Al (higher in the electrochemical series) comes in contact with less active metal Cu (lower in the electrochemical series) a galvanic cell is established. In this process active metal corrodes rapidly, while the other remains intact.

### 6.5.2 Prevention from Corrosion

It has been observed that the amount of iron destroyed each year by corrosion equals to about one fourth of its annual production. It is therefore necessary to prevent such a damaging process and avoid this loss.

Different methods are used to prevent corrosion. The simplest of them consists of protecting the surface of the metal from coming in direct contact with the surrounding by coating it with oil, paint, varnish or enamel. It can also be prevented by alloying the metals or by coating the metal with a thin layer of another metal.

### 6.5.3 Tin Plating or Coating Iron with Tin (cathode coating)

The process of tin plating consists of dipping the clean sheet of iron in a bath of molten tin and then passing it through hot pair of rollers. Such plates are used in the manufacture of tin cans, oil containers and other similar articles.

Tin itself is very stable and protects the metals effectively as long as its coating on the iron is intact.

If the protective coating is damaged, then iron comes into contact with moisture. A galvanic cell is established in which tin acts as a cathode and iron as an anode. The electrons flow from iron to tin, where they discharge  $H^+$  ions, leaving behind  $OH^-$  in the solution. These hydroxide ions react with iron forming  $Fe(OH)_2$ , which dissolves rapidly in water. From this, it can be concluded that plated iron gets rust more rapidly when the protective coating is damaged than the non-plated iron.

### 6.5.4 Galvanizing or Zinc Coating (anode coating)

Galvanizing is done by dipping a clean iron sheet in a zinc chloride bath and heating. The iron sheet is then removed, rolled into zinc bath and air cooled.

In this case, if a protective layer of zinc is damaged a galvanic cell is established in the presence of moisture. Iron serves as a cathode and zinc as an anode. Electrons flow from zinc to iron, as a result of which Zn decays while Fe remains intact. This is called **sacrificial corrosion**.



This is the way galvanizing helps protecting iron from rust. This process is used in water pipes, etc.

## 6.6 CHROMATES AND DICHROMATES

Chromates and dichromates are the salts of chromic acid,  $H_2CrO_4$ , and dichromic acid,  $H_2Cr_2O_7$ , respectively. Both acids exist only in aqueous solution and when attempts are made to isolate them from solution they decompose immediately into chromic anhydride ( $CrO_3$ ) and water. Their salts are, however, quite stable.

### 6.6.1 Potassium Chromate ( $K_2CrO_4$ )

#### Preparation

1. The chromates of alkali metals, which are soluble in water, are obtained by oxidizing trivalent chromium compounds in the presence of an alkali.

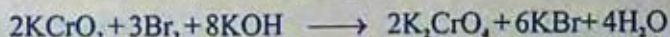

2. Chromates can also be produced by fusing  $Cr_2O_3$  with an alkali in the presence of an oxidant, such as potassium chlorate.



3. Chromates are usually prepared from natural chromite ( $FeO \cdot Cr_2O_3$ ), if the latter is strongly heated with potassium carbonate in the presence of the oxygen. The resulting fused mass will contain potassium chromate, which can be extracted with water.



### 6.6.2 Properties

#### Structure of Chromate Ion

Almost all the chromates are yellow in colour. Some of them are used as pigments. For instance, insoluble lead chromate,  $\text{PbCrO}_4$ , is employed for the preparation of yellow oil colour called yellow crown.

$\text{K}_2\text{CrO}_4$  and  $\text{K}_2\text{Cr}_2\text{O}_7$  show similar properties, because in an aqueous solution  $\text{Cr}_2\text{O}_7^{2-}$  and  $\text{CrO}_4^{2-}$  ions exist in equilibrium.



If an alkali is added to such a solution the hydroxyl ions will bind the hydrogen ion in solution, the equilibrium will shift towards left and, as a result, dichromate ions will be converted into chromate ions. Similarly on adding an acid the equilibrium will shift towards right and dichromate ions will be formed.

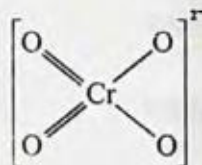

### 6.6.3 Potassium Dichromate ( $\text{K}_2\text{Cr}_2\text{O}_7$ )

#### Preparation

- $\text{K}_2\text{CrO}_4$  is converted to  $\text{K}_2\text{Cr}_2\text{O}_7$  by using the above mentioned equilibrium. In an acidic medium, the equilibrium will shift in the forward direction, i.e, changing chromate ions into dichromate ions.

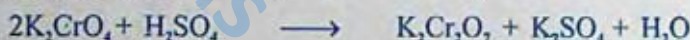

- Sometimes sodium dichromate is converted into potassium dichromate by reacting it with KCl.



### 6.6.4 Properties

#### Physical Properties

It is an orange red crystalline solid which melts at  $396^\circ\text{C}$ , it is fairly soluble in water.

Dichromates are very powerful oxidizing agents. Oxidation is carried out in an acid solution. In this process, hexavalent chromium ion is reduced to trivalent chromium ion.

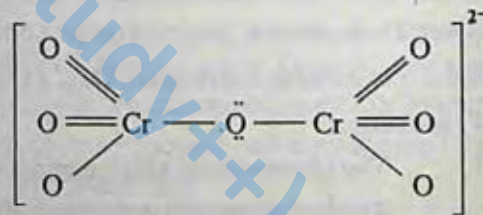

#### (a) Reaction With $\text{H}_2\text{S}$

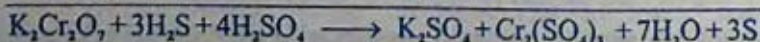
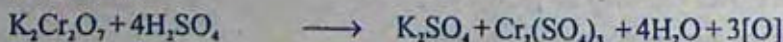

#### (b) Reaction with Ferrous Sulphate

Potassium dichromate oxidizes ferrous sulphate to ferric sulphate in the presence of

sulphuric acid.

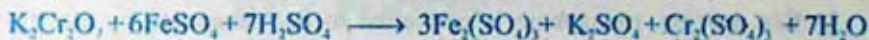

(c) **Reaction with Potassium Iodide**

Potassium dichromate also oxidizes KI in the presence of  $\text{H}_2\text{SO}_4$ ,

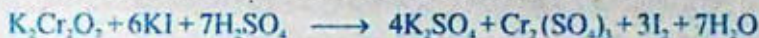

(d) **Chromyl Chloride Test**

When solid potassium dichromate is heated with solid metal chloride in the presence of concentrated sulphuric acid chromyl chloride is produced.

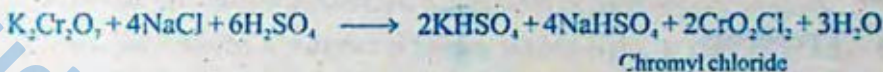

**Uses**

1.  $\text{K}_2\text{Cr}_2\text{O}_7$  finds extensive use in dyeing.
2. It is used in leather industries for chrome tanning.
3. It is used as an oxidizing agent.

**6.7 POTASSIUM PERMANGANATE ( $\text{KMnO}_4$ )**

This compound is the salt of permanganic acid,  $\text{HMnO}_4$ . It is an unstable acid and exists only in solution.

**Preparation**

It is prepared by acidifying the solution of potassium manganate,  $\text{K}_2\text{MnO}_4$  by  $\text{H}_2\text{SO}_4$ .

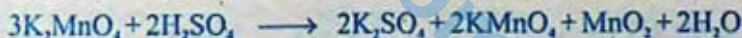

On a large scale it is prepared from the mineral pyrolusite,  $\text{MnO}_2$ . The finely powdered mineral is fused with  $\text{KOH}$  in the presence of air or an oxidizing agent like  $\text{KNO}_3$  or  $\text{KClO}_3$ , etc. This treatment gives us green coloured potassium manganate,  $\text{K}_2\text{MnO}_4$ , in fused state.



The fused  $\text{K}_2\text{MnO}_4$  obtained as above is extracted with water and the solution, after filtration, is converted into potassium permanganate ( $\text{KMnO}_4$ ) by any of the following methods.

(a) **Stadeler's Process**

In this method  $\text{Cl}_2$  is passed through the green solution of  $\text{K}_2\text{MnO}_4$  until it becomes purple due to the formation of  $\text{KMnO}_4$ . Here,  $\text{Cl}_2$  oxidizes  $\text{K}_2\text{MnO}_4$  into  $\text{KMnO}_4$ .



(b) In this process  $\text{CO}_2$  is passed through the green solution of  $\text{K}_2\text{MnO}_4$  until it becomes purple.

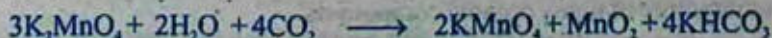

**(c) Electrolytic Oxidation Process**

In this process, manganate is converted to permanganate by electrolytic oxidation. During electrolysis of an aqueous solution of  $K_2MnO_4$ , water is decomposed to evolve hydrogen gas at the cathode and oxygen gas at the anode. Oxygen liberated at the anode oxidizes manganate ion  $(MnO_4)^{2-}$  into permanganate ion  $(MnO_4)^{-}$ , while hydrogen is liberated at the cathode.



The purple solution of  $KMnO_4$ , obtained as above is filtered through asbestos, concentrated and allowed to crystallize when  $KMnO_4$  deposits as deep purple-red rhombic prisms.

**6.7.1 Properties**

Potassium permanganate forms dark purple lustrous crystals giving deep pink colour in solution. Its solubility in water at  $20^\circ C$  is only about 7%, while it dissolves more at higher temperature (25% at  $63^\circ C$ ).

Potassium permanganate is a powerful oxidizing agent. Oxidation is usually carried out in an acid solution.

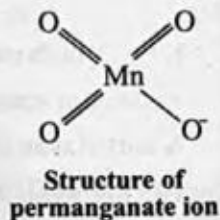
**(a) Reaction with  $H_2S$** 

It oxidises  $H_2S$  to sulphur.

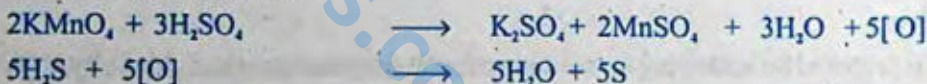
**(b) Reaction with  $FeSO_4$** 

It oxidizes  $FeSO_4$  to  $Fe_2(SO_4)_3$ .

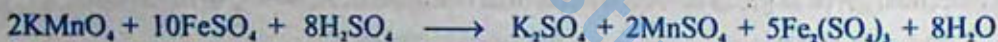
**(c) Reaction with Oxalic Acid**

It oxidizes oxalic acid to  $CO_2$  and  $H_2O$

**(d) Reaction with  $KOH$** 

When an alkaline solution of  $KMnO_4$  is heated,  $O_2$  is evolved.

**Uses**

It is used:

- i) as an oxidizing agent.
- ii) as a disinfectant and a germicide.
- iii) in the manufacture of many organic compounds.

## KEY POINTS

1. Transition elements have partially filled d or f-subshells in atomic state or in any of their commonly occurring oxidation states.
2. IIB and IIIB group elements are called non-typical transition elements.
3. Binding energies, melting points, paramagnetism and oxidation states of transition metals increase with increasing number of unpaired electrons.
4. Such compounds containing the complex molecules or complex ions and capable of independent existence are called coordination compounds or complex compounds.
5. When a complex ion absorbs a wavelength from visible light, it transmits a set of radiation that impart colour.
6. Wrought iron contains 0.12% – 0.25% carbon, while steel contains 0.25% – 2.25% carbon.
7. Chromate and dichromate ions exist in equilibrium in an aqueous solution.
8. Chemical decay of metals under the action of their surrounding medium is called corrosion. It can be prevented by tin plating and galvanizing.

## EXERCISE

### Q.1. Fill in the blanks.

- (i) The property of paramagnetism is due to the presence of \_\_\_\_\_ electrons.
- (ii)  $\text{MnO}_4^-$  ion has \_\_\_\_\_ colour and  $\text{Cr}_2\text{O}_7^{2-}$  has \_\_\_\_\_ colour.
- (iii) When potassium chromate is treated with an acid \_\_\_\_\_ is produced.
- (iv) The d-block elements are located between \_\_\_\_\_ and \_\_\_\_\_ block elements.
- (v) Oxidation number of Fe in  $\text{K}_4[\text{Fe}(\text{CN})_6]$  is \_\_\_\_\_ while in  $\text{K}_3[\text{Fe}(\text{CN})_6]$  it is \_\_\_\_\_.
- (vi) The presence of \_\_\_\_\_ in a metal promotes corrosion.
- (vii) If copper is in contact with aluminium \_\_\_\_\_ gets corroded.
- (viii) Complexes having  $sp^3d^2$  hybridization have \_\_\_\_\_ shape.
- (ix) In naming the complexes, all the ligands are named in \_\_\_\_\_.
- (x) In an aqueous solution,  $\text{CrO}_4^{2-}$  and  $\text{Cr}_2\text{O}_7^{2-}$  exist in the form of \_\_\_\_\_.

### Q.2. Indicate true or false.

- (i) A substance which is attracted into a magnetic field is said to be diamagnetic.
- (ii) Compounds of the transition elements are mostly coloured.
- (iii)  $\text{Fe}^{3+}$  ions are blue when hydrated.
- (iv) An extreme case of paramagnetism is called diamagnetism.
- (v) Tin plating is used to protect iron sheets from corrosion.

- (vi) In galvanizing, zinc prevents corrosion of iron.
- (vii) Tin plated iron gets rusted more rapidly when the protective coating is damaged than the unplated iron.
- (viii) The name of anionic ligands in a complex ends in suffix 'O'.
- (ix) Pig iron contains greater percentage of carbon than steel.
- (x) Complex compounds having  $dsp^2$  hybridization have tetrahedral geometry.

Q 3. Multiple choice questions. Encircle the correct answer.

- (i) Which of the following is a non-typical transition element?  
(a) Cr (b) Mn (c) Zn (d) Fe
- (ii) Which of the following is a typical transition metal?  
(a) Sc (b) Y (c) Ra (d) Co
- (iii) f-block elements are also called:  
(a) non-typical transition elements. (b) outer transition elements.  
(c) normal transition elements. (d) none is true
- (iv) The strength of binding energy of transition elements depends upon:  
(a) number of electron pairs (b) number of unpaired electrons  
(c) number of neutrons (d) number of protons
- (v) Group VIB of transition elements contains:  
(a) Zn, Cd, Hg (b) Fe, Ru, Os  
(c) Cr, Mo, W (d) Mn, Te, Re
- (vi) Which is the formula of tetraammine chloro-nitro-platinum (IV) sulphate?  
(a)  $[Pt(NH_3)_4(NO_2)]SO_4$  (b)  $[PtNO_2Cl(NH_3)_4]SO_4$   
(c)  $[PtCl(NO_2)(NH_3)_4]SO_4$  (d)  $[Pt(NH_3)_4(NO_2)Cl]SO_4$
- (vii) The percentage of carbon in different types of iron products is in the order of:  
(a) cast iron > wrought iron > steel (b) wrought iron > steel > cast iron  
(c) cast iron > steel > wrought iron (d) cast iron = steel > wrought iron.
- (viii) The colour of transition metal complexes is due to:  
(a) d-d transition of electrons.  
(b) paramagnetic nature of transition elements.  
(c) ionization.  
(d) loss of s-electrons.
- (ix) Coordination number of Pt in  $[PtCl(NO_2)(NH_3)_4]$  is:  
(a) 2- (b) 4 (c) 1 (d) 6

- (x) The total number of transition elements is:  
 (a) 10 (b) 14 (c) 40 (d) 58
- Q4. How does the electronic configuration of valence shell affect the following properties of the transition elements?  
 (a) Binding energy (b) Paramagnetism  
 (c) Melting points (d) Oxidation states
- Q5. Explain the following terms giving examples.  
 (a) Ligands (b) Coordination sphere  
 (c) Substitutional alloy (d) Central metal atom
- Q6. Describe the rules for naming the coordination complexes and give examples.
- Q7. What is the difference between wrought iron and steel? Explain the Bessemer's process for the manufacture of steel.
- Q8. Explain the following giving reasons.  
 (a) Why does damaged tin plated iron get rusted quickly?  
 (b) Under what conditions does aluminium corrode?  
 (c) How does the process of galvanizing protect iron from rusting?
- Q9. How chromate ions are converted into dichromate ions?
- Q10. Describe the preparation of  $\text{KMnO}_4$  and  $\text{K}_2\text{CrO}_4$ .
- Q11. Give systematic names to following complexes.  
 (a)  $[\text{Fe}(\text{CO})_5]$  (b)  $[\text{Co}(\text{NH}_3)_4]\text{Cl}_3$  (c)  $[\text{Fe}(\text{H}_2\text{O})_6]^{2+}$   
 (d)  $\text{Na}_3[\text{CoF}_6]$  (e)  $\text{K}_2[\text{Cu}(\text{CN})_4]$  (f)  $\text{K}_2[\text{PtCl}_6]$   
 (g)  $[\text{Pt}(\text{OH})_2(\text{NH}_3)_4]\text{SO}_4$  (h)  $[\text{Cr}(\text{OH})_3(\text{H}_2\text{O})_3]$

## CHAPTER

## 7

**FUNDAMENTAL PRINCIPLES  
OF ORGANIC CHEMISTRY****In this chapter you will learn**

1. The special features of carbon chemistry with reference to its ability to form chains, rings and isomers.
2. The importance of organic chemistry in daily life.
3. About the sources of carbon and its compounds like coal, petroleum and natural gas with reference to their availability in Pakistan.
4. Refining, reforming and cracking of petroleum and to enlist products in a tabular form.
5. How can petroleum serve as a source of different type of fuels?
6. About the classification of organic compounds based on the carbon skeleton.
7. About functional groups and the dependence of chemical properties on functional groups.
8. About the structural isomerism in organic compounds.
9. That cis-trans isomerism arises due to restricted rotation around a carbon-carbon double bond.
10. How the hybridization theory can help us understand the type of bonding and the shapes of organic compounds.

**7.1 INTRODUCTION**

More than 200 years ago, early chemists recognized organic compounds distinct from inorganic compounds because of the differences in their origin and properties. Organic compounds were considered as those obtained from living things, plants or animals, and inorganic compounds were those obtained from non-living or mineral sources. The early chemists never succeeded in synthesizing organic compounds and their failure led them to believe that organic compounds could be manufactured only by and within living things and these compounds could never be synthesized from inorganic materials. This theory was referred to as **vital force theory**. This theory was rejected by Friedrich Wohler when he obtained urea ( $\text{NH}_2\text{CO}$ ), an organic compound in the urine of mammals, from ammonium cyanate,  $\text{NH}_4\text{CNO}$ ,

a substance of known mineral origin.



### 7.1.1 Modern Definition of Organic Chemistry.

Since the synthesis of urea from ammonium cyanate, millions of organic compounds have been prepared and analyzed. All these compounds contain carbon as an essential element. Apart from carbon, most of the organic compounds also contain hydrogen. Other elements which may also be present include oxygen, nitrogen, sulphur, etc. For historical and conventional reasons a few of the carbon compounds such as CO, CO<sub>2</sub>, carbonates, bicarbonates, etc are studied as inorganic compounds. It also has been recognized that the chemical forces in organic compounds are similar to those, which exist, in inorganic compounds. Thus it was felt that organic chemistry should be redefined. According to the modern definition, organic chemistry is that branch of chemistry which deals with the study of compounds of carbon and hydrogen (hydrocarbons) and their derivatives.

## 7.2 SOME FEATURES OF ORGANIC COMPOUNDS

Following are some features of organic compounds.

### (1) Peculiar Nature of Carbon

Carbon forms a large number of compounds. There are millions of organic compounds known at present. The main reason for such a large number of compounds is its unique property of linking with other carbon atoms to form long chains or rings. This self linking property of carbon is called **catenation**. Carbon also forms stable single and multiple bonds with other atoms like oxygen, nitrogen and sulphur, etc. It can thus form numerous compounds of various sizes, shapes and structures.

### (2) Non-ionic Character of Organic Compounds

Organic compounds are generally covalent compounds, therefore, do not give ionic reactions.

### (3) Similarity in Behaviour

There exists a close relationship between different organic compounds. This is exemplified by the existence of homologous series. This similarity in behaviour has reduced the study of millions of compounds to only a few homologous series.

### (4) Complexity of Organic Compounds

Organic molecules are usually large and structurally more complex. For example, starch has the formula (C<sub>6</sub>H<sub>10</sub>O<sub>5</sub>)<sub>n</sub>, where n may be several thousands. Proteins are very complex molecules having molecular masses ranging from a few thousands to a million.

### (5) Isomerism

Isomerism is a very common phenomenon in organic compounds. Very often more than one compounds are represented by the same molecular formula. However, they have different structural formula.

### (6) Rates of Organic Reactions

The reactions involving organic compounds are slow and in general the yields are low. The slow rate of the organic reactions is due to the molecular nature of organic compounds.

### (7) Solubility

Most organic compounds are insoluble in water and dissolve readily in non-polar organic solvents, such as, benzene, petroleum ether, etc.

## 7.3 IMPORTANCE OF ORGANIC CHEMISTRY

The importance of organic chemistry can hardly be over emphasized. Almost all the chemical reactions that take place in living systems, including our own bodies, are organic in nature because they involve such life molecules like proteins, enzymes, carbohydrates, lipids, vitamins and nucleic acids, all contain thousands of carbon atoms. We have become dependent upon organic compounds that occur in nature for our food, medicines and clothing. Over the years, the chemists have learnt to synthesize plastics, synthetic rubber, medicines, preservatives, paints, varnishes, textile fibres, fertilizers, pesticides, detergents, cosmetics, dyes, etc. Many of these synthetic compounds make up for the shortages of naturally occurring products.

## 7.4 SOURCES OF ORGANIC COMPOUNDS

Petroleum, coal and natural gas are vast reservoirs from which many organic compounds are obtained. These are called fossil fuels and are formed, over long period of time, from the decay of plants and animals.

### Coal

It is believed that coal in nature was formed from the remains of the trees buried inside the earth crust some 500 millions years ago. Due to the bacterial and chemical reactions on wood it got converted into peat. Then, as a result of high temperature and high pressure inside the earth crust, peat got transformed into coal.

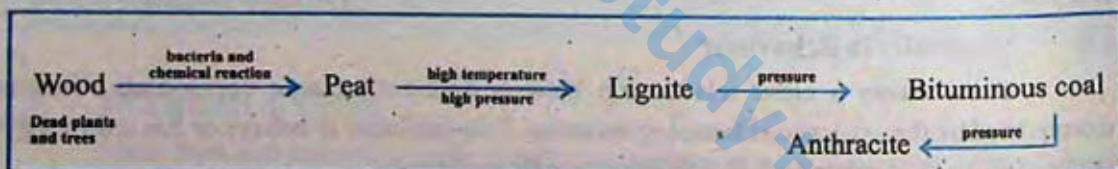

Coal is an important solid fuel and a source of organic compounds when subjected to carbonization or destructive distillation. When coal is heated in the absence of air (temperature ranging from 500-1000°C); it is converted into coke, coal gas and coal tar. Coal tar contains a large number of organic compounds, which separate out on fractional distillation.

The total coal resources of Pakistan are estimated by the geological survey of Pakistan to be 184 billion tonnes. About 80% of this coal is used to bake bricks, in lime kilns; besides, some quantity is used as a fuel for domestic purposes.

Serious efforts are being made by the Government to induct coal into industry by setting

up coal based power units. The Sindh Coal Authority and the directorates of Mineral Developments of the Punjab, Baluchistan and Khyber Pakhtunkhwa are all keen to expand coal utilization in power generation for which many incentives have been made available.

### Natural Gas

Natural Gas is an important means of energy especially for countries like Pakistan, which are deficient in the production of mineral oil and coal.

It is a mixture of low boiling hydrocarbons. Major portion of the natural gas is methane. It is also formed by the decomposition of organic matter. In Pakistan the gas, being cheaper, is used for power generation, in cement and fertilizer industries; as a fuel in industries and homes.

### Petroleum

Mineral oil is called petroleum when it is in the refined form. It is thought to have been formed by slow chemical and biochemical decomposition of the remains of organic matters found between the sedimentary rocks. When extracted from rocks it appears like a liquid of blackish colour known as 'crude oil'. It is refined to get different petroleum fractions. At present four oil refineries are in operation in our country. One oil refinery known as Attock Oil Refinery is located at Morgah near Rawalpindi. It has about 1.25 million tonnes oil refining capacity. Similarly, two oil refineries established at Karachi which have about 2.13 million tonnes of oil refining capacity. Another refinery known as Pak-Arab refinery is located at Mahmud Kot near Multan.

The crude petroleum is separated by fractional distillation into a number of fractions each corresponding to a particular boiling range, Table 7.1.

**Table 7.1 Principal Fractions Obtained from Petroleum**

Fraction	Boiling Point Range (°C)	Composition	Uses
Natural gas	< 20	$\text{CH}_4 - \text{C}_4\text{H}_{10}$	Fuel, petrochemicals
Petroleum Ether	20 - 60	$\text{C}_5\text{H}_{12} - \text{C}_6\text{H}_{14}$	Solvent
Ligroin, or naphtha	60 - 100	$\text{C}_6\text{H}_{14}, \text{C}_7\text{H}_{16}$	Solvent, raw material
Gasoline	40- 220	$\text{C}_4\text{H}_{10} - \text{C}_{13}\text{H}_{28}$ mostly $\text{C}_6\text{H}_{14} - \text{C}_8\text{H}_{18}$	Motor fuel
Kerosene	175 - 325	$\text{C}_8\text{H}_{18}, \text{C}_{14}\text{H}_{30}$	Heating fuel
Gas oil	> 275	$\text{C}_{12}\text{H}_{26}, \text{C}_{18}\text{H}_{38}$	Diesel and heating fuel
Lubricating oils and greases	Viscous liquids	$> \text{C}_{18}\text{H}_{38}$	Lubrication
Paraffin	M.p. 50 - 60	$\text{C}_{23}\text{H}_{48} - \text{C}_{29}\text{H}_{60}$	Wax products
Asphalt, or petroleum coke	Solids	Residue	Roofing, paving, fuel reducing agent

## 7.5 CRACKING OF PETROLEUM

The fractional distillation of petroleum yields only about 20% gasoline. Due to its high demand this supply is augmented by converting surplus supplies of less desirable petroleum fractions such as kerosene oil and gas oil into gasoline by a process called cracking. It is defined as breaking of higher hydrocarbons having high boiling points into a variety of lower hydrocarbons, which are more volatile (low boiling). For example, a higher hydrocarbons  $C_{16}H_{34}$  splits according to the following reaction.

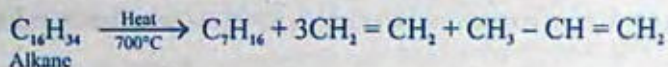

This is the process in which C-C bonds in long chain alkane molecules are broken, producing smaller molecules of both alkanes and alkenes. The composition of the products depends on the condition under which the cracking takes place. Cracking is generally carried out in the following ways.

### (1) Thermal Cracking

Breaking down of large molecules by heating at high temperature and pressure is called **Thermal Cracking**. It is particularly useful in the production of unsaturated hydrocarbons such as ethene and propene.

### (2) Catalytic Cracking

Higher hydrocarbons can be cracked at lower temperature ( $500^{\circ}\text{C}$ ) and lower pressure (2 atm), in the presence of a suitable catalyst. A typical catalyst used for this purpose is a mixture of silica ( $\text{SiO}_2$ ) and alumina ( $\text{Al}_2\text{O}_3$ ). Catalytic cracking produces gasoline of higher octane number and, therefore, this method is used for obtaining better quality gasoline.

### (3) Steam Cracking

In this process, higher hydrocarbons in the vapour phase are mixed with steam, heated for a short duration to about  $900^{\circ}\text{C}$  and cooled rapidly. The process is suitable for obtaining lower unsaturated hydrocarbons.

Besides increasing the yield of gasoline, cracking has also produced large amounts of useful by-products, such as ethene, propene, butene and benzene. These are used for manufacturing drugs, plastics, detergents, synthetic fibres, fertilizers, weed killers and important chemicals like ethanol, phenol and acetone.

## 7.6 REFORMING

The gasoline fraction present in petroleum is generally not of good quality. When it burns in an automobile engine, combustion can be initiated before the spark plug fires. This produces a sharp metallic sound called **knocking** which greatly reduces the efficiency of an engine. The quality of a fuel is indicated by its octane number. As the octane number increases,

the engine is less likely to produce knocking. Straight-chain hydrocarbons have low octane numbers and are poor fuels. Experiments have shown that isooctane or 2,2,4-trimethyl pentane burns very smoothly in an engine and has been arbitrarily given an octane number of 100.

The octane number of gasoline is improved by a process called **reforming**. It involves the conversion of straight chain hydrocarbons into branched chain by heating in the absence of oxygen and in the presence of a catalyst.

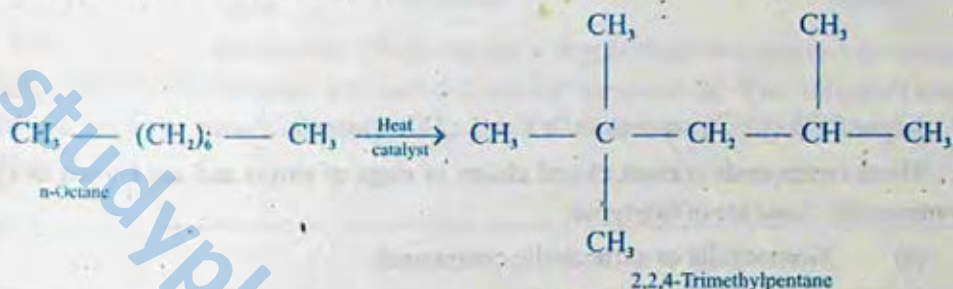

The octane number of a poor fuel can also be improved by blending it with a small amount of additive like tetraethyl lead (TEL). Tetraethyl lead ( $\text{C}_2\text{H}_5$ )<sub>4</sub>Pb, is an efficient antiknock agent but has one serious disadvantage; its combustion product, lead oxide, is reduced to metallic lead which is discharged into the air through the exhaust pipe and causes air pollution.

## 7.7 CLASSIFICATIONS OF ORGANIC COMPOUNDS

There are millions of organic compounds. It is practically not possible to study each individual compound. To facilitate their study, organic compounds are classified into various groups and sub-groups. They may be broadly classified into the following classes.

1. Open chain or Acyclic compounds.
2. Closed chain or Cyclic (or ring) compounds.

### (1) Open Chain or Acyclic Compounds

This type of compounds contain an open chain of carbon atoms. The chains may be branched or straight. The open chain compounds are also called aliphatic compounds.

#### Straight Chain Compounds

Those organic compounds in which the carbon atoms are connected in series from one to the other.

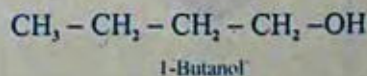
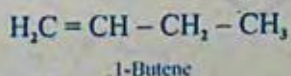
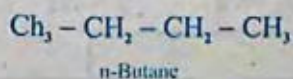

### Branched chain compounds

Those organic compounds in which the carbon atoms are attached on the sides of chain.

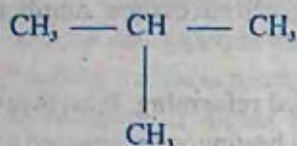

2-Methylpropane  
(Isobutane)

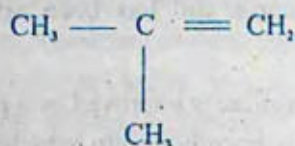

2-Methylpropene  
(Isobutylene)

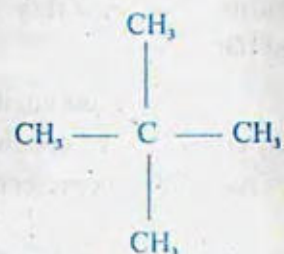

2, 2, 4-Dimethylpropane (neopentane)

### (2) Closed Chain Compounds or Cyclic Compounds

These compounds contain closed chains or rings of atoms and are known as cyclic or ring compounds. These are of two types;

- Homocyclic or carbocyclic compounds
- Heterocyclic compounds

The classification of organic compounds into various classes is shown in Fig. 7.1.

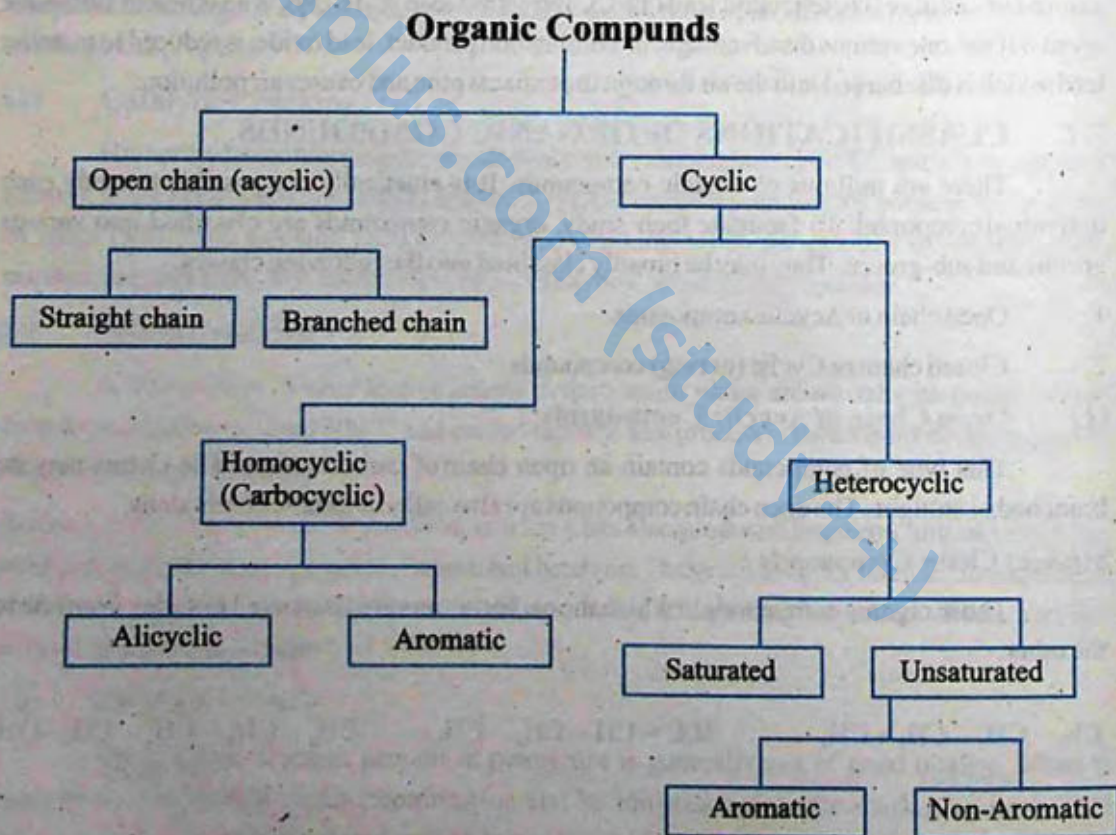

Table 7.1 Classification of organic compounds

**(a) Homocyclic or Carbocyclic Compounds**

The compounds in which the ring consists of only carbon atoms are called homocyclic or carbocyclic compounds.

Homocyclic compounds are further classified as:

1. Alicyclic compounds
2. Aromatic compounds

**(1) Alicyclic Compounds**

The homocyclic compounds which contain a ring of three or more carbon atoms and resembling aliphatic compounds are called alicyclic compounds. The saturated alicyclic hydrocarbons have the general formula  $C_nH_{2n}$ . Typical examples of alicyclic compounds are given below.

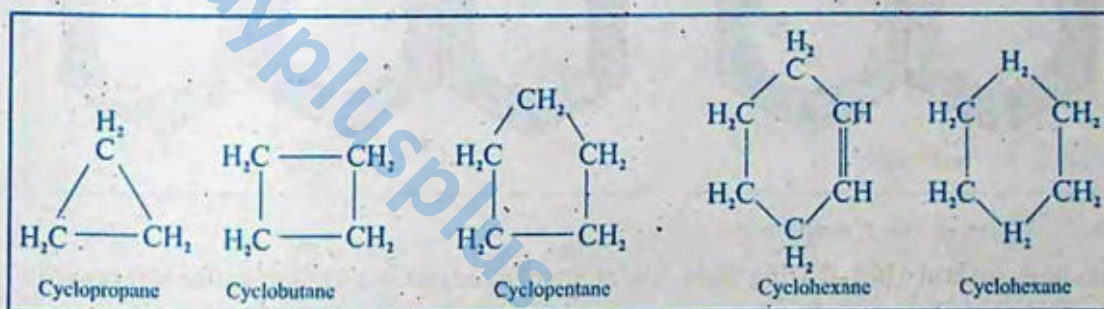

One or more hydrogen atoms present in these compounds may be substituted by other group or groups.

**(2) Aromatic Compounds**

These carbocyclic compounds contain at least one benzene ring, six carbon atoms with three alternate double and single bonds. These bonds are usually shown in the form of a circle. Typical examples of aromatic compounds are given below.

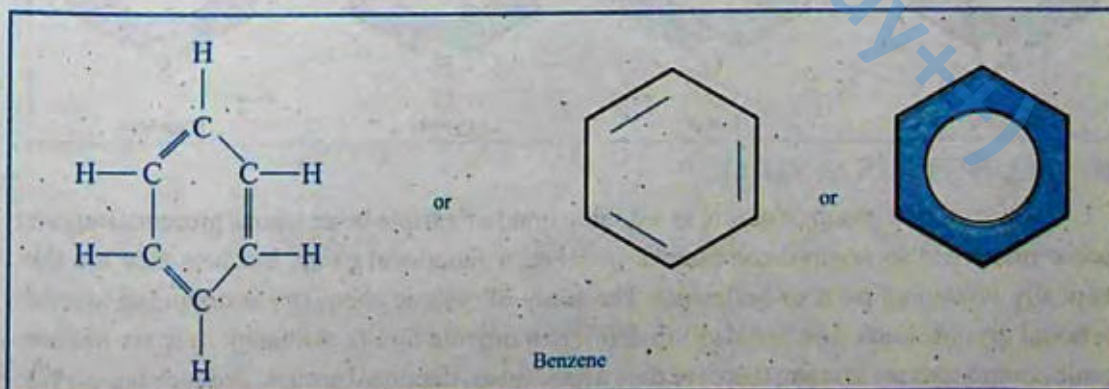

The aromatic compounds may have a side-chain or a functional group attached to the ring. For example:

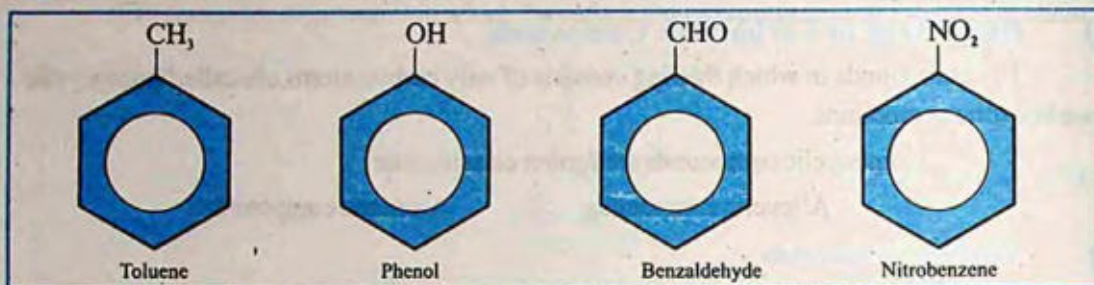

The aromatic compounds may also contain more than one benzene rings fused together.

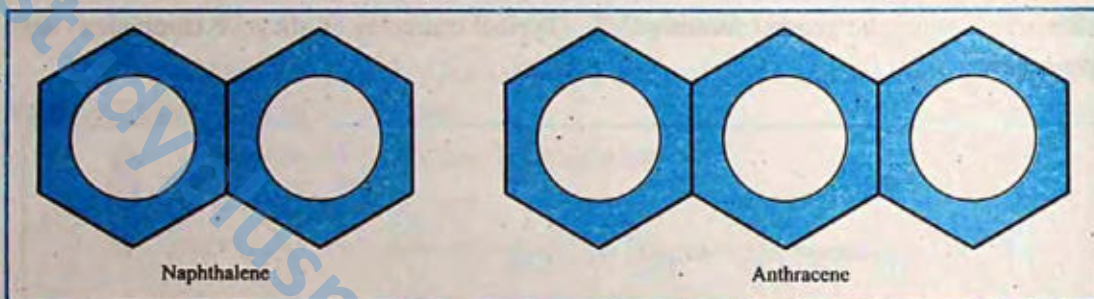

### (b) Heterocyclic Compounds

The compounds in which the ring consists of atoms of more than one kind are called **heterocyclic** compounds or **heterocycles**. In heterocyclic compounds generally one or more atoms of elements such as nitrogen (N), oxygen (O) or sulphur (S) are present. The atom other than carbon viz, N, O, or S, present in the ring is called a **hetero atom**.

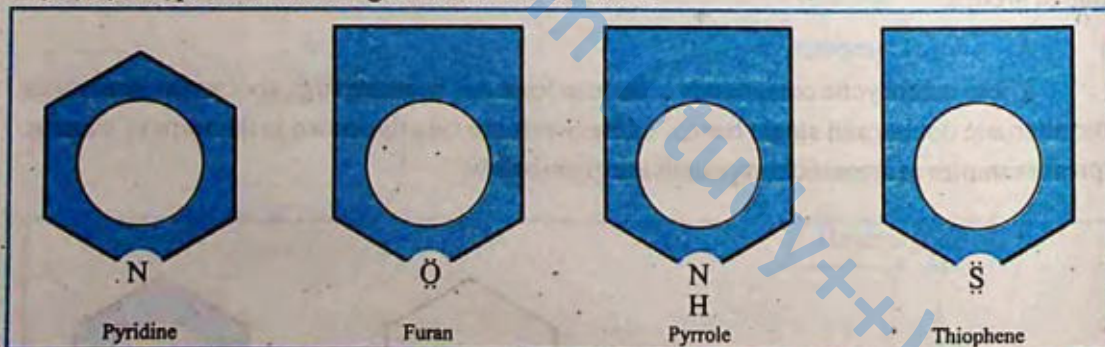

## 7.8 FUNCTIONAL GROUP

An atom or a group of atoms or a double bond or a triple bond whose presence imparts specific properties to organic compounds is called a functional group, because they are the chemically functional parts of molecules. The study of organic chemistry is organized around functional groups. Each functional group defines an organic family. Although over six million organic compounds are known, there are only a handful of functional groups, and each one serves to define a family of organic compounds. The examples of functional groups are outlined in Table 7.2.

TABLE 7.2 FUNCTIONAL GROUPS

Functional-group		Class of compounds	Example
Formula	Name		
	None	Alkane	$\text{H}_3\text{C}-\text{CH}_3$
	Double bond	Alkene	$\text{H}_2\text{C}=\text{CH}_2$
	Triple bond	Alkyne	$\text{HC}\equiv\text{CH}$
$-\text{X}(\text{X}=\text{F}, \text{Cl}, \text{Br}, \text{I})$	Halo (fluoro, chloro, bromo, iodo)	Alkyl halide	$\text{CH}_3-\text{CH}_2-\text{Cl}$
$-\text{OH}$	Hydroxyl group	Alcohol or alkanol	$\text{CH}_3-\text{CH}_2-\text{OH}$
$-\text{NH}_2$	Amino group	Amine	$\text{CH}_3-\text{CH}_2-\text{NH}_2$
	Imino group	Imine	$\text{CH}_2=\text{NH}$
	Ether linkage	Ether	$\text{CH}_3-\text{CH}_2-\text{O}-\text{CH}_2-\text{CH}_3$
	Formyl group	Aldehyde or alkanal	
	Carbonyl	Ketone or alkanone	
	Carboxyl group	Carboxylic acid (alkanoic acid)	
	Acid halide	Acid halide	
	Acid amide	Acid amide	
	Ester group	Ester	
$-\text{SH}$	Mercapto	Thioalcohol or Thiol	$\text{CH}_3-\text{CH}_2-\text{SH}$
$-\text{C}\equiv\text{N}$	Cyano (Nitrile)	Alkyl cyanide or alkane nitrile	$\text{CH}_3-\text{C}\equiv\text{N}$
	Nitro	Nitro compounds	$\text{C}_6\text{H}_5\text{NO}_2$

## 7.9 HYBRIDIZATION OF ORBITALS AND THE SHAPES OF MOLECULES

Although the most stable electronic configuration of a carbon atom (having two partially filled 2p orbitals) requires it to be divalent, carbon is tetravalent in the majority of its compounds. In order to explain this apparent anomaly, it is assumed that an electron from the 2s orbital is promoted to an empty 2p<sub>z</sub> orbital, giving the electronic configuration:

Ground state electronic configuration of carbon =  $1s^2 2s^1 2p_x^1 2p_y^1 2p_z^0$

Excited state electronic configuration of carbon =  $1s^2 2s^1 2p_z^1 2p_x^1 2p_y^1$

The excited state configuration can explain the tetravalency of carbon but these four valencies will not be equivalent. Orbital hybridization theory has been developed to explain the equivalent tetravalency of carbon.

According to this theory the four atomic orbitals of carbon belonging to valence shell may be mixed in different ways to explain the bonding and shapes of molecules formed by carbon atoms.

### sp<sup>3</sup> Hybridization

In order to explain the bonding and shapes of molecules in which carbon is attached with four atoms, all these four atomic orbitals are mixed together to give rise to four new equivalent hybrid atomic orbitals having same shape and energy. This mode of hybridization is called tetrahedral or sp<sup>3</sup> hybridization.

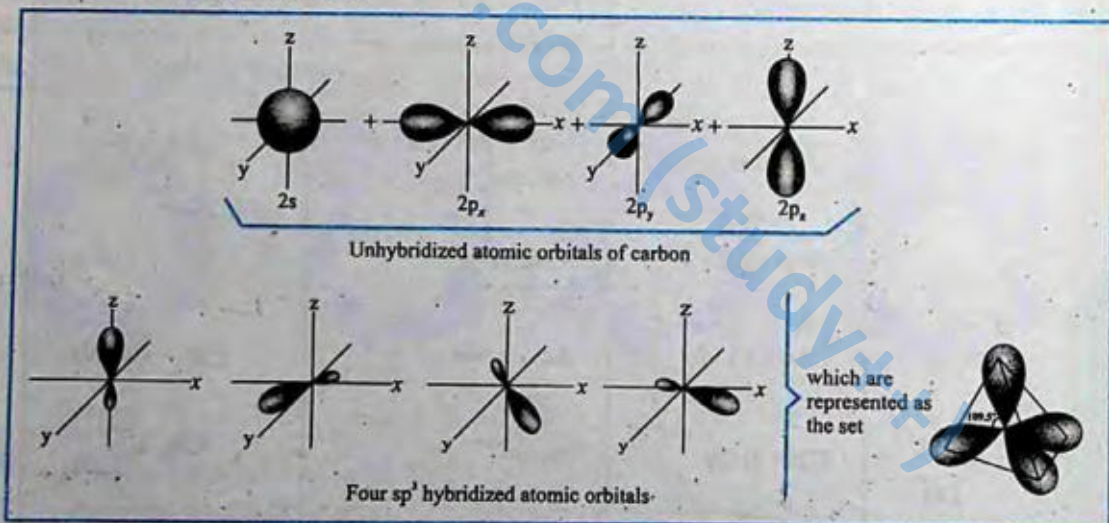
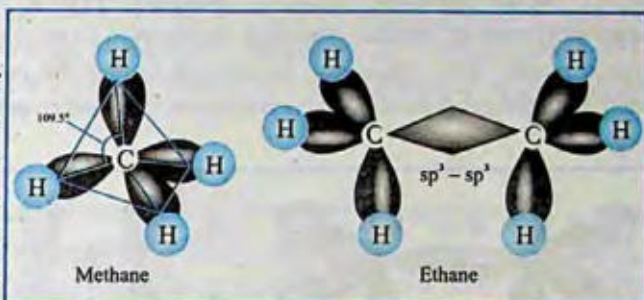

Fig. 7.2 sp<sup>3</sup> hybridization of carbon

All these four sp<sup>3</sup> hybrid orbitals are degenerate (having equal energy) and are directed at an angle of 109.5° in space to give a tetrahedral geometry.

When a carbon atom forms single bond with other atoms, these hybrid orbitals overlap with the orbitals of these atoms to form four sigma bonds. This type of hybridization explains the bonding and shapes of all those compounds in which carbon atom is saturated.

In the formation of methane, the four hybrid atomic orbitals of carbon overlap separately with four 1s atomic orbitals of hydrogen to form four equivalent C-H bonds. The shape of methane thus formed is very similar to the actual methane molecule. All the four hydrogen atoms do not lie in the same plane.



$sp^3$  hybridization in methane and ethane

In ethane,  $\text{CH}_3 - \text{CH}_3$ , the two tetrahedrons of each carbon are joined together as shown in the above figure. Further addition of a carbon atom with ethane will mean the attachment of another tetrahedron.

At this stage, it is necessary to answer an important question. From where does the energy come to excite the carbon atom?

The answer to this question is simple. Before excitation the carbon should make two covalent bonds releasing an adequate amount of energy. After excitation, however, it will form four covalent bonds releasing almost double the amount of energy. This excess energy is more than that needed to excite the carbon atom. So a tetravalent carbon atom is expected to be more stable than a divalent carbon atom.

### $sp^2$ Hybridization

In order to explain the bonding in unsaturated compounds, two more modes of hybridization have been developed. The structure of alkenes can be explained by  $sp^2$  mode of hybridization. In this type one 2s and two 2p orbitals of carbon are mixed together to give three equivalent and coplanar  $sp^2$  hybridized orbitals, Fig. 7.3.

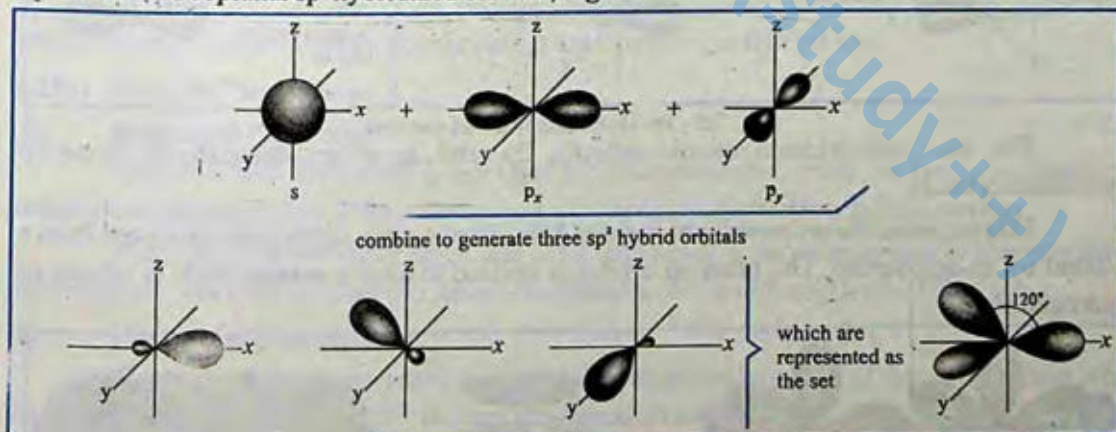

Fig. 7.3  $sp^2$  hybridization of carbon

Each  $sp^2$  hybrid orbital is directed from the centre of an equilateral triangle to its three corners. The bond angle between any two  $sp^2$  hybrid orbitals is  $120^\circ$ . The unhybridized 2p<sub>z</sub> orbital will remain perpendicular to the triangle thus formed.

In the formation of ethene molecule, three  $sp^2$  orbitals of each carbon atom overlap separately with  $sp^2$  orbital of another carbon and 1s orbitals of two hydrogen atoms to form three sigma bonds. This gives rise to what is called the  $\sigma$ -frame work of ethene molecule. The unhybridized orbitals of each carbon atom will then overlap in a parallel way to form a  $\pi$ -bond, Fig. 7.4.

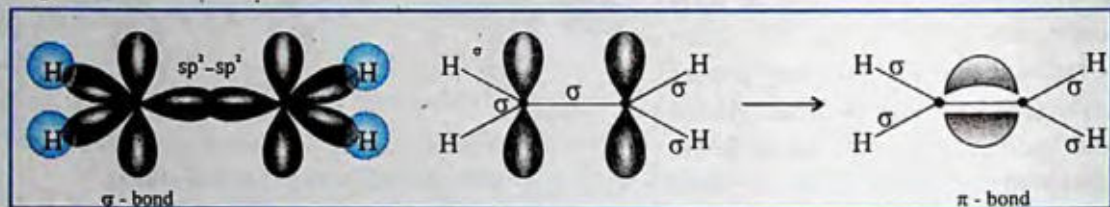

Fig. 7.4 Formation of ethene

### sp-Hybridization

The structure of alkynes can be explained by yet another mode of hybridization called **sp hybridization**. In this type one 2s and one 2p orbitals of the carbon atom mix together to give rise to two degenerate sp hybridized atomic orbitals. These orbitals have a linear shape with a bond angle  $180^\circ$ .

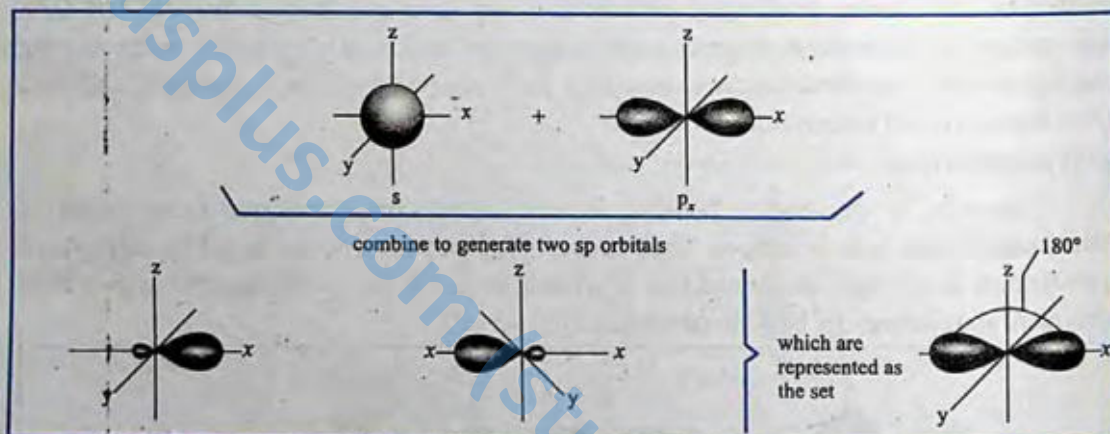

Fig. 7.5  $sp$ -Hybridization of carbon

The two unhybridized atomic orbitals,  $2p_y$  and  $2p_z$ , are perpendicular to these  $sp$  hybridized orbitals.

Ethyne molecule is formed when two  $sp$  hybridized carbon atoms join together to form a  $\sigma$ -bond by  $sp-sp$  overlap. The other  $sp$  orbital is utilized to form a  $\sigma$ -bond with 1s orbital of hydrogen atom.

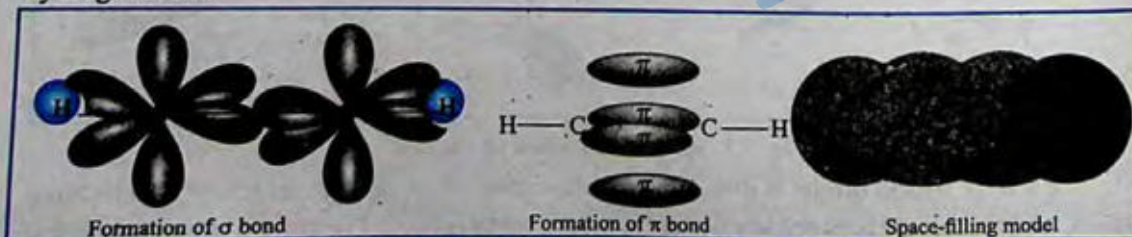
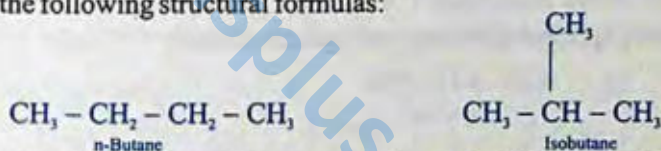

Fig. 7.6 Formation of ethyne

The two unhybridized p orbitals on a carbon atom will overlap separately with the p orbitals of the other carbon atom to give two  $\pi$ -bonds both perpendicular to the  $\sigma$ -framework of ethyne. The presence of a  $\sigma$  and two  $\pi$ -bonds between two carbon atoms is responsible for shortening the bond distance.

## 7.10 ISOMERISM

The concept of isomerism is an important feature of organic compounds. Two or more compounds having the same molecular formula but different structural formulas and properties are said to be isomers and the phenomenon is called isomerism. The structural formula of a compound shows the arrangement of atoms and bonds present in it. The simplest hydrocarbon to have structural isomers is butane ( $C_4H_{10}$ ). The alkanes, methane, ethane and propane do not show the phenomenon of isomerism because each exists in one structural form only. If we study the structural formula of butane or other higher hydrocarbons of the alkane family, we will observe that it is possible to arrange the atoms present in the molecule in more than one way to satisfy all valencies. This means that it is possible to have two or more different arrangements for the same molecular formula. For example, butane molecule can have two different arrangements as represented by the following structural formulas:



This fact has been supported by an experimental evidence that there are two compounds with different physical properties but with the same molecular formula of  $C_4H_{10}$ .

Isomerism is not only possible but common if the compound contains more than three carbon atoms. As the number of carbon atoms in a hydrocarbon increases, the number of possible isomers increases very rapidly.

The five carbon compound, pentane, has three isomers. When the number of carbon atoms increases to thirty, the number of isomers amount to over four billions.

### 7.10.1 Types of Isomerism

#### (I) Structural Isomerism

The structural isomerism is not confined to hydrocarbons only. In fact, all classes of organic compounds and their derivatives show the phenomenon of structural isomerism.

The structural isomerism arises due to the difference in the arrangement of atoms within the molecule. The structural isomerism can be exhibited in five different ways. These are:

#### (i) The Chain Isomerism.

This type of isomerism arises due to the difference in the nature of the carbon chain. For example, for pentane ( $C_5H_{12}$ ), the following arrangements are possible.

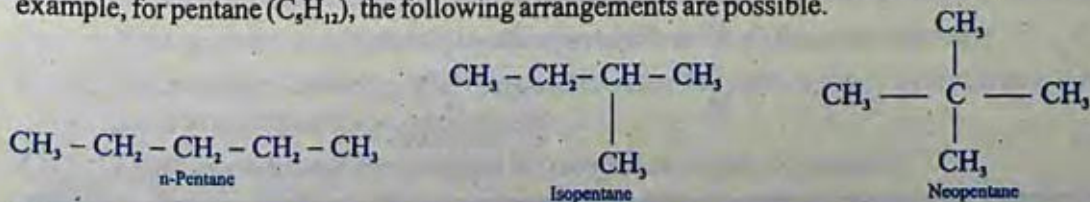

**(ii) Position Isomerism.**

This type of isomerism arises due to the difference in the position of the same functional group on the carbon chain.

The arrangement of carbon atoms remains the same.

For example,

(a) Chloropropane can have two positional isomers given below.

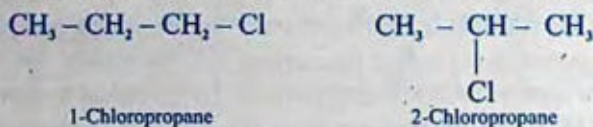

(b) Butene ( $\text{C}_4\text{H}_8$ ) can have two positional isomers.

**(iii) Functional Group Isomerism**

The compounds having the same molecular formula but different functional groups are said to exhibit functional group isomerism. For example, there are two compounds having the same molecular formula  $\text{C}_2\text{H}_6\text{O}$ , but different arrangement of atoms.

**(iv) Metamerism**

This type of isomerism arises due to the unequal distribution of carbon atoms on either side of the functional group. Such compounds belong to the same homologous series. For example, diethyl ether and methyl n-propyl ether are metamers.

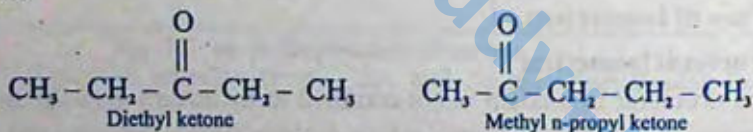

For a ketonic compound having the molecular formula  $\text{C}_5\text{H}_{10}\text{O}$ , the following two metamers are possible.

**(v) Tautomerism**

This type of isomerism arises due to shifting of proton from one atom to other in the same molecule.

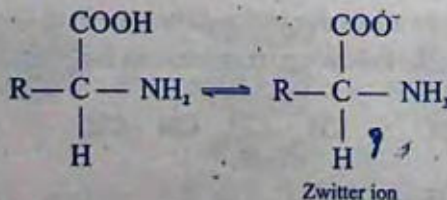

## (2) Cis-trans Isomerism or Geometric Isomerism

Two carbon atoms joined by a single bond are capable of free rotation about it. However, when two carbon atoms are joined by a double bond, they cannot rotate freely. As a result, the relative positions of the various groups attached to these carbon atoms get fixed and gives rise to cis-trans isomers.

Such compounds which possess the same structural formula, but differ with respect to the positions of the identical groups in space are called cis-trans isomers and the phenomenon is known as the cis-trans or geometric isomerism.

The necessary and sufficient condition for a compound to exhibit geometric isomerism is that the two groups attached to the same carbon must be different.

2-Butene can exist in the form of cis and trans isomers.

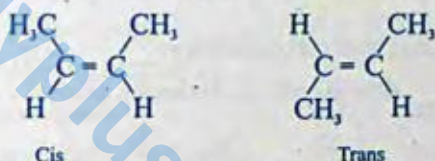

Similarly 2-pentene and 1-bromo-2-chloropropene also show cis-trans isomerism.

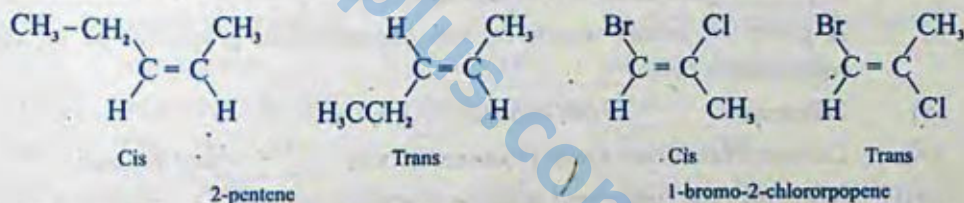

In the cis-form, the similar groups lie on the same side of the double bond whereas in the trans-form, the similar groups lie on the opposite sides of the double bond. The rotation of two carbon atoms joined by a double bond could happen only if the  $\pi$ -bond breaks. This ordinarily costs too much energy, making geometric isomers possible.

### KEY POINTS

1. Chemical compounds were classified as organic and inorganic compounds based upon their origin. Organic compounds are obtained from living things whereas inorganic compounds are obtained from mineral sources.
2. It was thought that organic compounds could not be synthesized in the laboratory from inorganic sources.
3. Organic chemistry is nowadays defined as the chemistry of hydrocarbons and their derivatives.
4. Most of the commercially important compounds we use everyday are organic in nature.
5. Coal, petroleum and natural gas are important sources of organic compounds.
6. The process of cracking is developed to increase the yield of lower hydrocarbons which serve as important fuels commercially.
7. Organic compounds are classified into acyclic and cyclic compounds.

8. The study of organic chemistry is organized around functional groups. Each functional group defines an organic family.
9. The type of bonding and the shapes of different types of compounds formed by carbon can be explained by  $sp^3$ ,  $sp^2$  and  $sp$  modes of hybridization.
10. Compounds having the same molecular formula but different structural formulas are called isomers. There are four different types of structural isomers.
11. Isomerism arising due to restricted rotation around a carbon-carbon double bond is called cis-trans isomerism.

## EXERCISE

### Q1. Fill in the blanks

- i) Organic compounds having same molecular formula but different \_\_\_\_\_ are called isomers.
- ii) The state of hybridization of carbon atom in \_\_\_\_\_ is  $sp^2$ .
- iii) Alkenes show \_\_\_\_\_ due to restricted rotation around a carbon-carbon double bond.
- iv) Heating an organic compound in the absence of oxygen and in the presence of \_\_\_\_\_ as a catalyst is called cracking.
- v) A group of atoms which confers characteristic properties to an organic compound is called \_\_\_\_\_.
- vi) 2-Butene is \_\_\_\_\_ of 1-butene.
- vii) Carbonyl functional group is present in both \_\_\_\_\_ and ketones.
- viii) A heterocyclic compound contains an atom other than \_\_\_\_\_ in its ring.
- ix) The quality of gasoline can be checked by finding out its \_\_\_\_\_.
- x) A carboxylic acid contains \_\_\_\_\_ as a functional group.

### Q2. Indicate true or false.

- (i) There are three possible isomers of pentane.
- (ii) Alkynes do not show the phenomenon of cis-trans isomerism.
- (iii) Organic compounds can not be synthesized from inorganic compounds.
- (iv) All close chain compounds are aromatic in nature.
- (v) The functional group present in amides is called an amino group.
- (vi) Government of Pakistan is trying to use coal for power generation.
- (vii) Crude petroleum is subjected to fractional distillation in order to separate it into different fractions.
- (viii) A bond between carbon and hydrogen serves as a functional group for alkanes.
- (ix) o-Nitrotoluene and p-nitrotoluene are the examples of functional group isomerism.
- (x) Almost all the chemical reactions taking place in our body are inorganic in nature.

Q3. Multiple choice questions. Encircle the correct answer.

- (i) The state of hybridization of carbon atom in methane is:  
 (a)  $sp^3$  (b)  $sp^2$  (c)  $sp$  (d)  $dsp^2$
- (ii) In t-butyl alcohol, the tertiary carbon is bonded to:  
 (a) two hydrogen atoms (b) three hydrogen atoms  
 (c) one hydrogen atom (d) no hydrogen atom
- (iii) Which set of hybrid orbitals has planar triangular shape.  
 (a)  $sp^3$  (b)  $sp$  (c)  $sp^2$  (d)  $dsp^2$
- (iv) The chemist who synthesized urea from ammonium cyanate was:  
 (a) Berzelius (b) Kolbe (c) Wholer (d) Lavoisier
- (v) Linear shape is associated with which set of hybrid orbitals?  
 (a)  $sp$  (b)  $sp^2$  (c)  $sp^3$  (d)  $dsp^2$
- (vi) A double bond consists of:  
 (a) two sigma bonds (b) one sigma and one pi bond  
 (c) one sigma and two pi bonds (d) two pi-bonds
- (vii) Ethers show the phenomenon of:  
 (a) position isomerism (b) functional group isomerism  
 (c) metamerism (d) cis-trans isomerism
- (viii) Select from the following the one which is alcohol:  
 (a)  $CH_3-CH_2-OH$  (b)  $CH_3-O-CH_3$   
 (c)  $CH_3COOH$  (d)  $CH_3-CH_2-Br$

Q4. How are organic compounds classified? Give suitable examples of each type.

Q5. What are homocyclic and heterocyclic compounds? Give one example of each.

Q6. Write the structural formulas of the two possible isomers of  $C_4H_{10}$ .

Q7. Why is ethene an important industrial chemical?

Q8. What is meant by a functional group? Name typical functional groups containing oxygen.

Q9. What is an organic compound? Explain the importance of Wohler's work in the development of organic chemistry.

Q10. Write a short note on cracking of hydrocarbons.

Q11. Explain reforming of petroleum with the help of suitable example.

Q12. Describe important sources of organic compounds.

Q13. What is orbital hybridization? Explain  $sp^3$ ,  $sp^2$  and  $sp$  modes of hybridization of carbon.

Q14. Explain the type of bonds and shapes of the following molecules using hybridization approach.

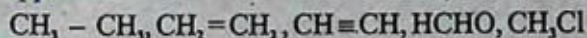

Q15. Why there is no free rotation around a double bond and a free rotation around a single bond? Discuss cis-trans isomerism.

# CHAPTER 8

## ALIPHATIC HYDROCARBONS

### In this chapter you will learn

1. How to name the aliphatic hydrocarbons according to IUPAC rules.
2. The synthesis of alkanes, alkenes and alkynes and their important reactions.
3. The comparison of reactivity of  $\sigma$  bond and  $\pi$  bond.
4. About the free radical nature of reactions of alkanes and electrophilic addition of alkenes and alkynes.
5. The comparison of reactivities of alkanes, alkenes and alkynes.

### 8.1 INTRODUCTION

Hydrocarbons are organic compounds which contain carbon and hydrogen only. The number of such compounds is very large because of the property of catenation. Hydrocarbons have been divided into various classes on the basis of structure of the chain or size and nature of the ring.

## HYDROCARBONS

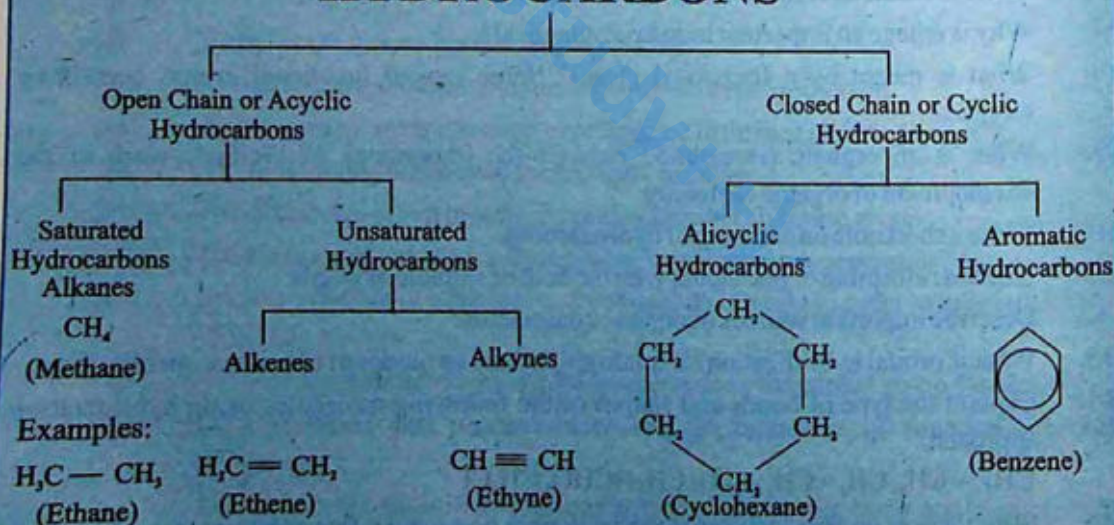

If all the valencies of the carbon atoms in a molecule are fully satisfied and these cannot further take up any more hydrogen atoms, then the hydrocarbons are named as saturated hydrocarbons or alkanes. The compounds of carbon and hydrogen in which all the four valencies of carbon are not fully utilized and they contain either a double or a triple bond, such compounds are called unsaturated hydrocarbons.

Those unsaturated hydrocarbons which contain a double bond are called alkenes while those containing a triple bond are called alkynes. Classification of hydrocarbons has been shown at page 136.

## 8.2 NOMENCLATURE

### 8.2.1 Common or Trivial Names

In the early days, the compounds were named on the basis of their history, the method of preparation or name of the person working on it, e.g., the name marsh gas was given to methane because it was found in marshy places. Acetic acid derives its name from vinegar (Latin, acetum means vinegar). Organic compounds were named after a person, like barbituric acid after Barbara. Such a system may have a certain charm but is never manageable.

For alkanes with five or more carbon atoms, the root word is derived from the Greek or Latin numerals indicating the number of carbon atoms in a molecule, and the name is completed by adding 'ane' as a suffix, e.g. pentane ( $C_5H_{12}$ ), hexane ( $C_6H_{14}$ ), heptane ( $C_7H_{16}$ ), etc. The common or trivial names are applicable to all isomers of a given molecular formula. The prefixes n, iso, neo are, however, to differentiate between isomers.

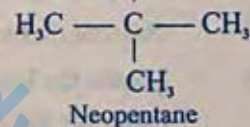
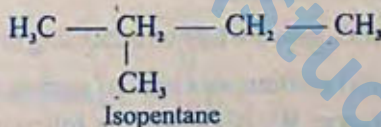
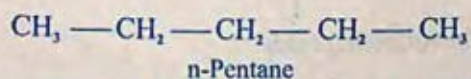
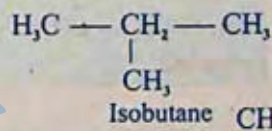
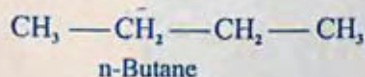

These prefixes have only limited use, as they are not workable with complex molecules. Moreover, common names give only minimum information about the structure of the compounds.

Alkenes are similarly named by replacing the ending 'ane' of the name of alkane with 'ylene'. e.g.

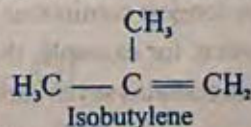
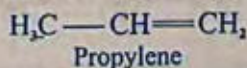
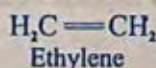

### 8.2.2 IUPAC Names

In 1889 the solution for naming the organic compounds systematically was sought by International Chemical Congress. A report was accepted in 1892 in Geneva but it was found



2. Number the longest chain beginning from the end of the chain nearer the substituent. Applying this rule, we number the two alkanes shown above in the following way.

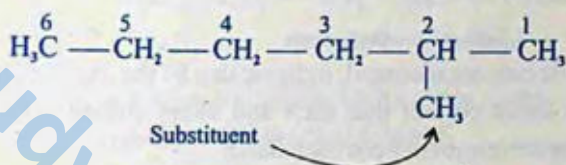
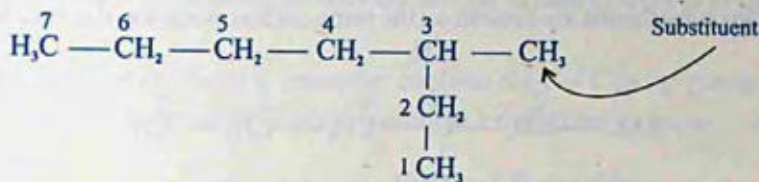

3. Use the numbers obtained by the application of rule 2 to designate the location of the substituent group. The parent name is placed last, and the substituent group, preceded by the number designating its location on the chain, is placed first. Numbers are separated from words by a hyphen. The systematic names of the two compounds shown above will then be:

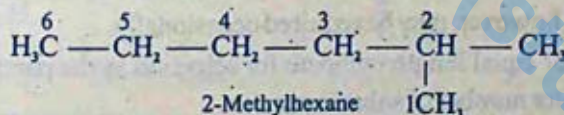
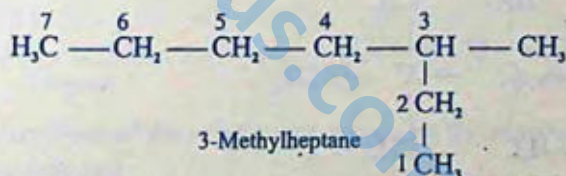

4. When two or more substituents are present, give each substituent a number corresponding to its location on the longest chain. For example, we designate the following compound as 4-ethyl-2-methylhexane.

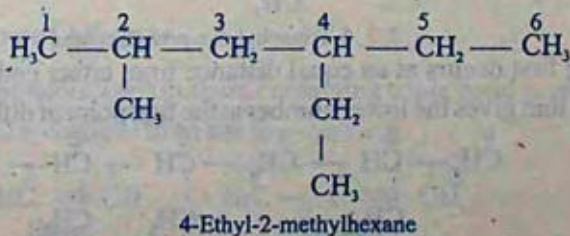

The substituent groups should be listed alphabetically (i.e. ethyl before methyl). In deciding on alphabetical order disregard multiplying prefixes such as "di" and "tri".

5. When two substituents are present on the same carbon atom, use that number twice.

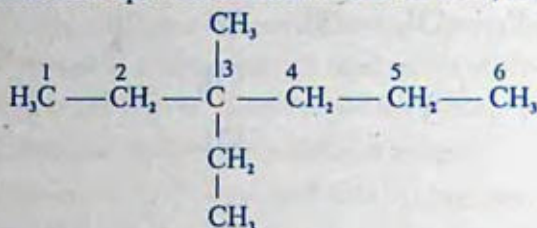

3-Ethyl-3-methylhexane

6. When two or more substituents are identical, indicate this by the use of the prefixes di, tri, tetra, and so on. Then make certain that each and every substituent has a number. Commas are used to separate numbers from each other.

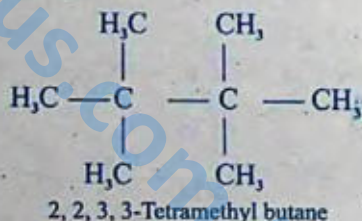
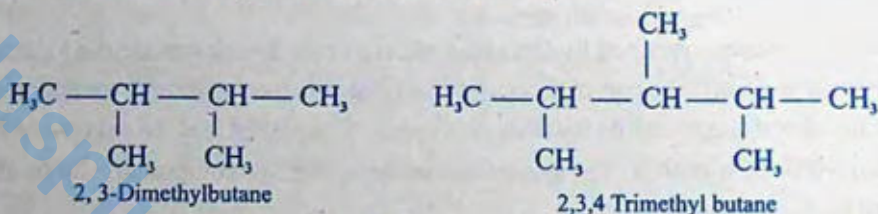

Application of these six rules allows us to name most of the alkanes that we shall encounter. Two other rules, however, may be required occasionally.

7. When two chains of equal length compete for selection as the parent chain, choose the chain with the greater number of substituents.

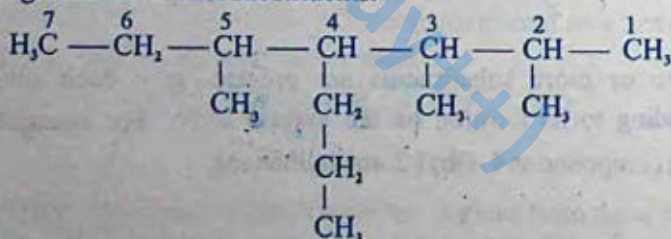

8. When branching first occurs at an equal distance from either end of the longest chain, choose the name that gives the lower number at the first point of difference.

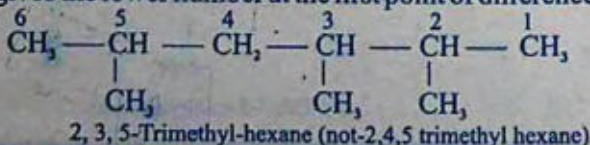





The hydrogenation can also be carried out with platinum or palladium at room temperature but they are expensive than nickel.

The method is of industrial importance. Production of vegetable ghee by the catalytic hydrogenation of vegetable oil (unsaturated fatty acids) is an example of the application of this method on industrial scale.

### (2) From Alkyl Halides:

An alkane is produced when an alkyl halide reacts with zinc in the presence of an aqueous acid.

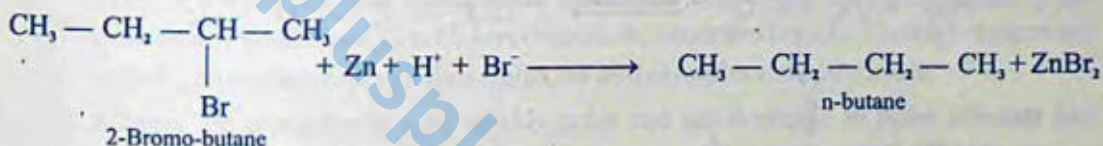
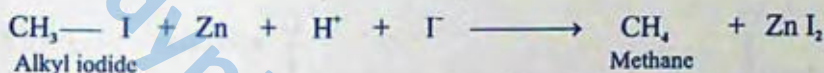
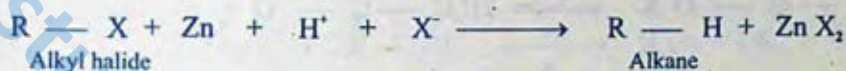

Alkanes can also be prepared from alkyl halides using palladium-charcoal as a catalyst. The method is known as Hydrogenolysis (hydrogenation accompanied by bond cleavage).

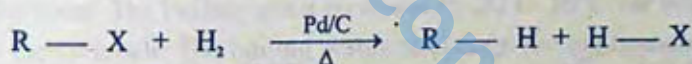

### (3) Decarboxylation of Monocarboxylic Acids

- i) When sodium salts of fatty acids are heated with sodalime (prepared by soaking quick lime (CaO) with caustic soda solution and drying the product). They eliminate a molecule of  $\text{CO}_2$  to form alkanes.

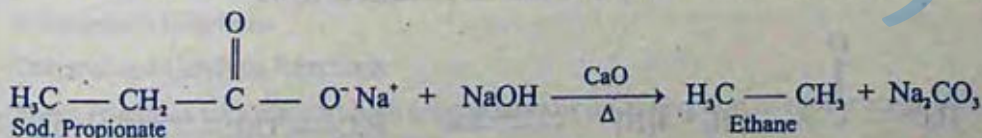
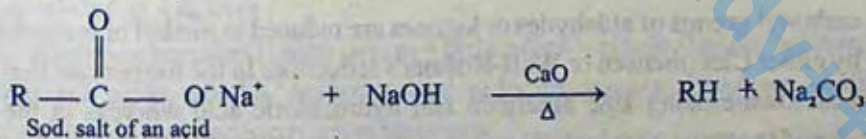

### ii) Kolbe's Electrolytic Method

When a concentrated solution of sodium or potassium salt of a mono carboxylic acid is electrolysed, an alkane is produced. This method is only suitable for the preparation of symmetrical alkanes i.e. those of the type R — R. Methane cannot be prepared by this method.



It is known to involve the following mechanism.

When potassium salt of acetic acid is electrolysed, acetate ion migrates towards the anode, gives up one electron to produce acetate free radical ( $\text{CH}_3\text{COO}\cdot$ ), which decomposes to give a methyl free radical ( $\dot{\text{C}}\text{H}_3$ ) and  $\text{CO}_2$ . Two such methyl radicals combine to give ethane.

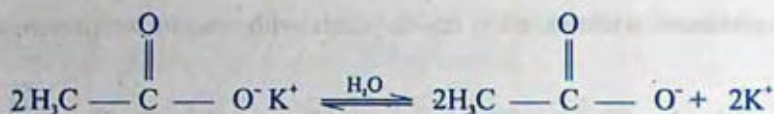

**At Anode**

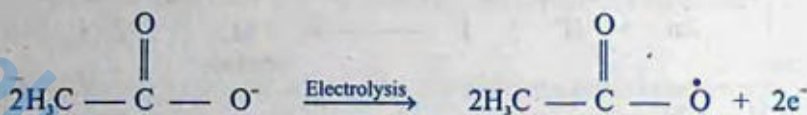

**At Cathode**



This reaction has limited synthetic applications as it forms a number of side products.

#### (4) From Carbonyl Compounds (Aldehydes or Ketones)

The carbonyl groups of aldehydes or ketones are reduced to methyl or methylene group respectively by either Clemmensen or Wolf-Kishner's reduction. In the former reaction a ketone is reduced to an alkane using zinc amalgam and hydrochloric acid whereas in the later an aldehyde is reduced to alkane with hydrazine in the presence of KOH.

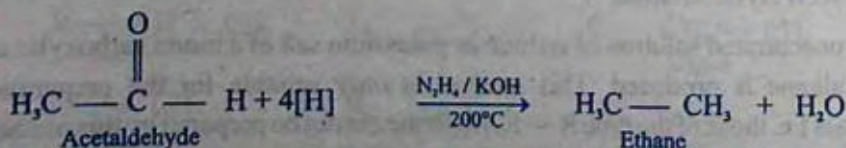
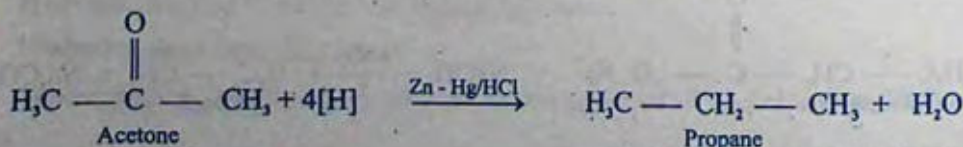

**(5) From Grignard Reagents**

Alkyl halides react in anhydrous ether with magnesium to form alkyl magnesium halides, known as Grignard Reagent. They decompose on treatment with water or dilute acid to give alkanes.

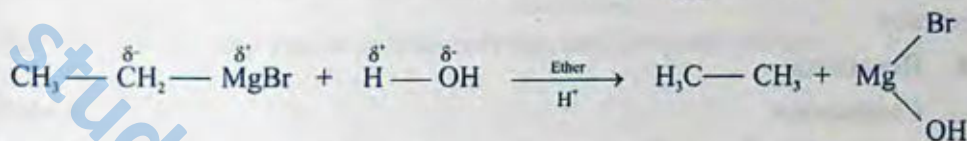
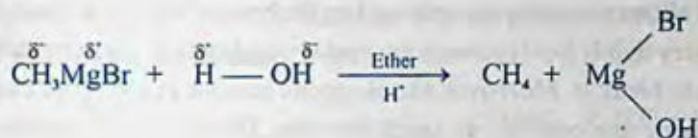
**8.3.2. Physical Properties**

- Alkanes containing upto four carbon atoms are colourless, odourless gases while pentane to heptadecane ( $\text{C}_5$  to  $\text{C}_{17}$ ) are colourless, odourless liquids. The higher members from  $\text{C}_{18}$  onwards are waxy solids which are also colourless and odourless.
- Alkanes are non-polar or very weakly polar and are insoluble in polar solvents like water, but soluble in non-polar solvents like benzene, ether, carbon tetrachloride, etc.
- Their physical constants like boiling points, melting points, density, etc increase with the increase in number of carbon atoms, whereas solubility decreases with increase in molecular mass. The boiling point increases by 20 to 30°C for addition of each  $\text{CH}_2$  group to the molecule. The boiling points of alkanes having branched chain structures are lower than their isomeric normal chain alkanes, e.g. n-butane has a higher boiling point  $-0.50^\circ\text{C}$  than isobutane ( $-11.7^\circ\text{C}$ ).
- The melting points of alkanes also increase with the increase in molecular mass but this increase is not regular.

**8.3.3. Reactivity of Alkanes**

The alkanes or paraffins (Latin: parum = little, affins = affinity) under ordinary condition are inert towards acids, alkalis, oxidizing and reducing agents. However, under suitable conditions, alkanes do undergo two types of reactions.

- Substitution Reactions
- Thermal and Catalytic Reactions

These reactions take place at high temperature or on absorption of light energy through the formation of highly reactive free radicals.

The unreactivity of alkanes under normal conditions may be explained on the basis of the non-polarity of the bonds forming them. The electronegativity values of carbon (2.5) and hydrogen (2.1) do not differ appreciably and the bonding electrons between C-H and C-C are

equally shared making them almost non-polar. In view of this, the ionic reagents such as acids, alkalies, oxidizing agents, etc find no reaction site in the alkane molecules to which they could be attached.

### Inertness of $\sigma$ -bond

The unreactivity of alkanes can also be explained on the basis of inertness of a  $\sigma$ -bond. In a  $\sigma$ -bond the electrons are very tightly held between the nuclei which makes it a very stable bond. A lot of energy is required to break it. Moreover, the electrons present in a  $\sigma$ -bond can neither attack on any electrophile nor a nucleophile can attack on them. Both these facts make alkanes less reactive.

## 8.3.4 Reactions

### 1. Combustion

Burning of an alkane in the presence of oxygen is known as Combustion.

Complete combustion of an alkane yields  $\text{CO}_2$ ,  $\text{H}_2\text{O}$  and heat. The amount of heat evolved when one mole of a hydrocarbon is burnt to  $\text{CO}_2$  and  $\text{H}_2\text{O}$  is called heat of combustion, e.g;

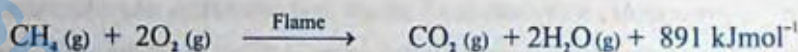

Although the reaction is highly exothermic, it requires very high temperature to initiate it, e.g. by a flame or a spark.

Combustion is the major reaction occurring in the internal combustion engines of automobiles. A compressed mixture of alkanes and air burns smoothly in the internal combustion engine and increases its efficiency.

### 2. Oxidation

Oxidation of methane under different conditions gives different products.

- i) Incomplete oxidation occurs in a limited supply of oxygen or air and results in the formation of  $\text{CO}$  and carbon black.

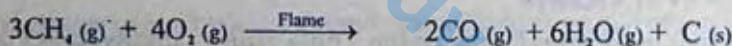

### ii) Catalytic Oxidation

Lower alkanes when burnt in the presence of metallic catalysts, at high temperature and pressure, result in the formation of useful products.

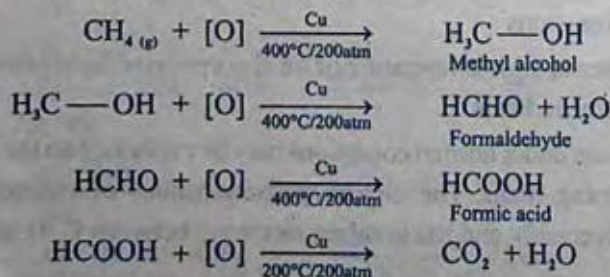

Catalytic oxidation of alkanes is used industrially to prepare higher fatty acids used in soap and vegetable oil industries.

### 3. Nitration

It is a substitution reaction of alkanes in which a hydrogen atom of an alkane is replaced by nitro group ( $-\text{NO}_2$ ). Alkanes undergo vapour-phase nitration under drastic condition (at  $400\text{--}500^\circ\text{C}$ ) to give nitroalkanes, e.g.



Nitroalkanes generally find use as fuels, solvents, and in organic synthesis.

### 4. Halogenation

Alkanes react with chlorine and bromine in the presence of sunlight or UV light or at high temperature resulting in the successive replacement of hydrogen atoms with halogens called halogenation. Extent of halogenation depends upon the amount of halogen used.

Reaction of alkanes with fluorine is highly violent and results in a mixture of carbon, fluorinated alkanes and hydrofluoric acid. Iodine does not substitute directly because the reaction is too slow and reversible. The order of reactivity of halogens is  $\text{F}_2 > \text{Cl}_2 > \text{Br}_2 > \text{I}_2$ .

Halogenation is believed to proceed through free radical mechanism. It involves the following three steps.

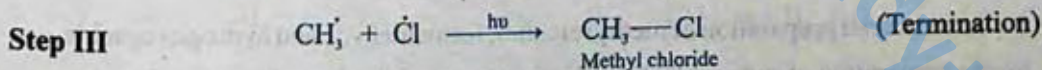
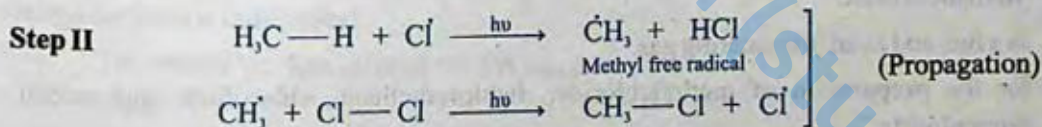
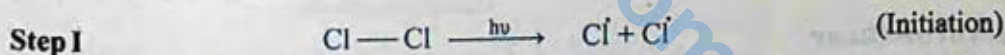

By repetition of step II, a mixture of halogen substituted products are obtained. The reaction is not synthetically so important.

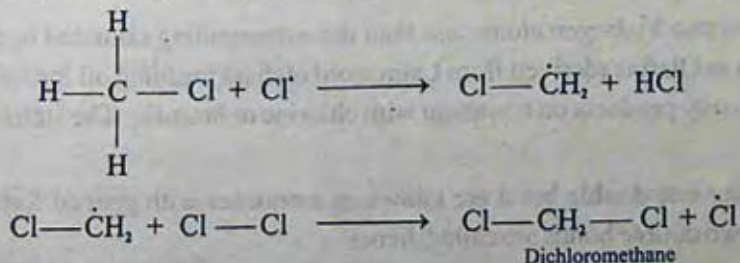

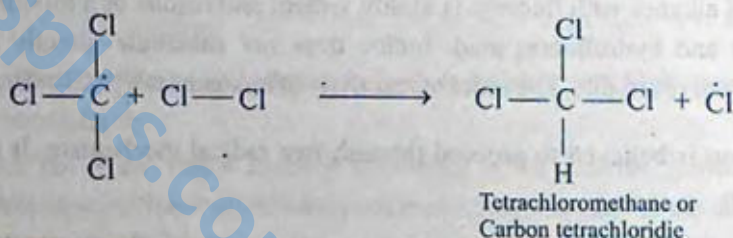
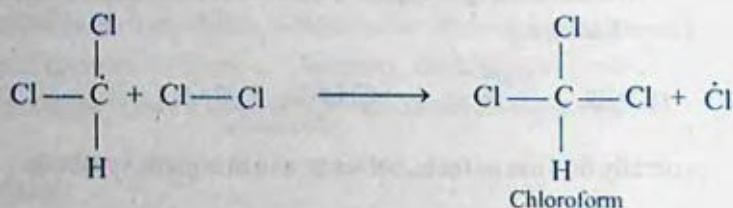
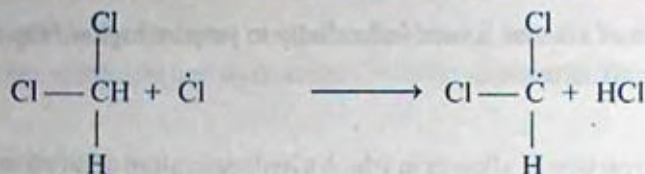

### 8.3.5 Uses of Methane

Methane is used:

- (i) as a fuel and as an illuminating gas.
- (ii) for the preparation of methylchloride, dichloromethane, chloroform and carbon tetrachloride.
- (iii) for the industrial preparation of methyl alcohol, formaldehyde and hydrogen cyanide.
- (iv) for the preparation of carbon black used in paints, printing inks and automobile tyres.
- (v) is used to manufacture urea fertilizer.

## 8.4 ALKENES

Alkenes have two hydrogen atoms less than the corresponding saturated hydrocarbons. They are also known as Olefins (derived from Latin word olefiant meaning oil forming) because lower members form oily products on treatment with chlorine or bromine. The simplest olefin is  $\text{C}_2\text{H}_4$ , ethene.

Alkene having one double bond are known as monoenes with general formula  $\text{C}_n\text{H}_{2n}$ . Alkenes containing two double bonds are called dienes.

## 8.4.1 General Methods of Preparation

### 1. Dehydrohalogenation of Alkyl Halides

Alkyl halides on heating with alcoholic potassium hydroxide undergo dehydrohalogenation i.e. elimination of a halogen atom together with a hydrogen atom from adjacent carbon atoms.

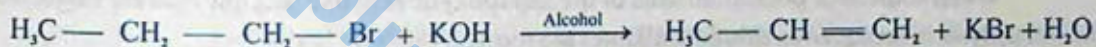
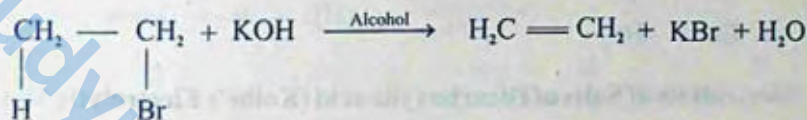
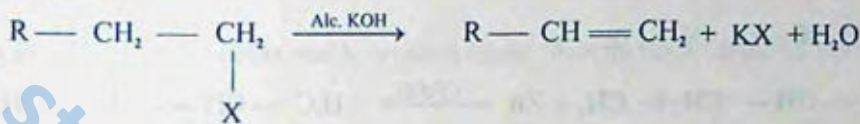

### 2. Dehydration of Alcohols

Alcohols when dehydrated in the presence of a catalyst give alkene. The best procedure is to pass vapours of alcohol over heated alumina.

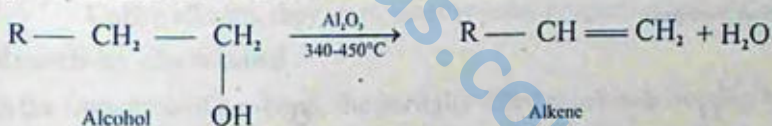

$\text{P}_2\text{O}_5$ , (conc) $\text{H}_2\text{SO}_4$  and  $\text{H}_3\text{PO}_4$  are also used for dehydration. The ease of dehydration of various alcohols is in the order:

Ter. alcohol > Sec. alcohol > Pri. alcohol

Thus

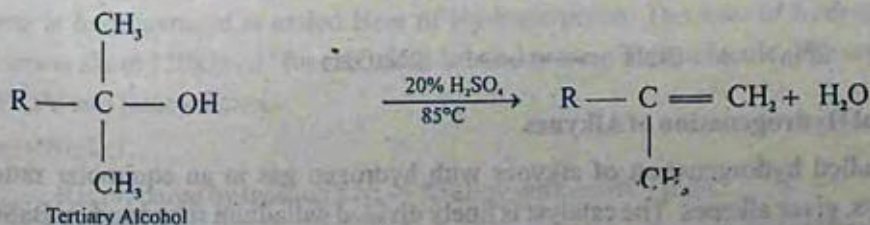
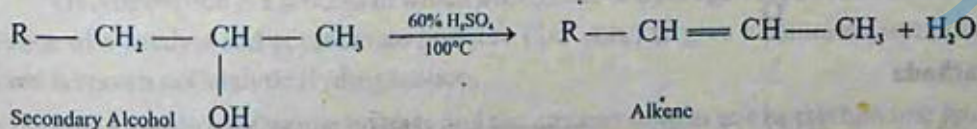
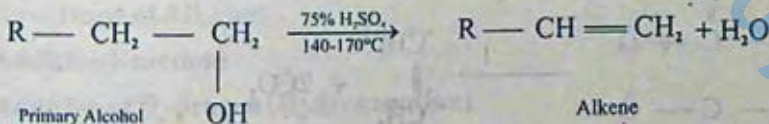

### 3. Dehalogenation of Vicinal Dihalides

Vicinal dihalides have two halogens on adjacent carbon atoms. Dehalogenation occurs when dihalide is treated with Zinc dust in an anhydrous solvent like methanol or acetic acid.

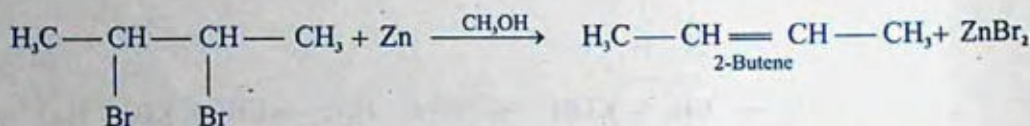
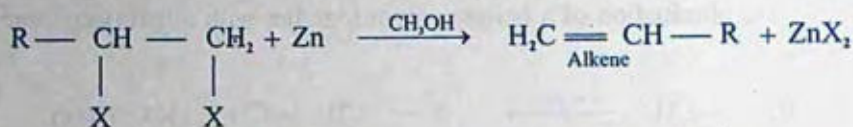

### 4. Electrolysis of Salts of Dicarboxylic acid (Kolbe's Electrolytic Method)

When sodium or potassium salts of the dicarboxylic acid like succinic acid are subjected to electrolysis in an aqueous solution, alkenes are formed.

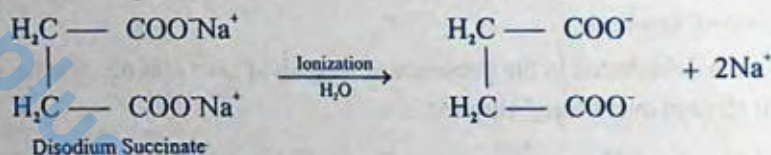

At Anode

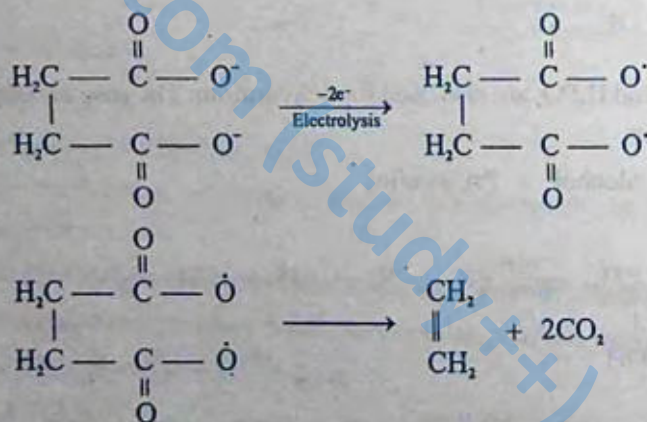

At Cathode



### 5. Partial Hydrogenation of Alkynes

Controlled hydrogenation of alkynes with hydrogen gas in an equimolar ratio over heated catalysts, gives alkenes. The catalyst is finely divided palladium supported on  $\text{BaSO}_4$  and

poisoned by treatment with quinoline (Lindlar's catalyst).

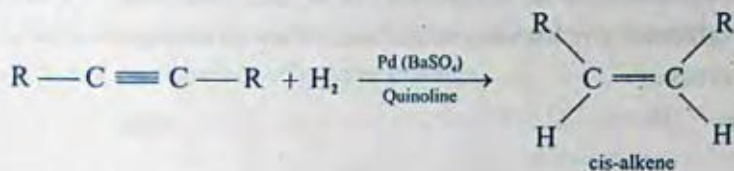

A trans alkene can be obtained by treating an alkyne with Na in liquid  $\text{NH}_3$  at  $-33^\circ\text{C}$ .

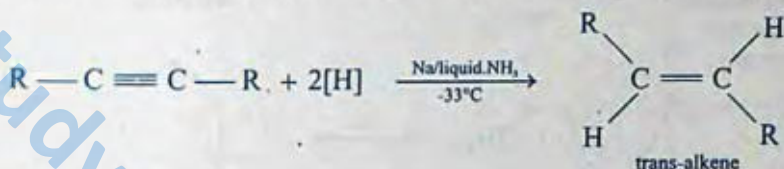

### 8.4.2 Physical Properties

1. First three members i.e. ethene, propene and butane are gases at room temperature while  $\text{C}_5$  to  $\text{C}_{15}$  are liquids and the higher members are solids.
2. They are insoluble in water but soluble in alcohol.
3. They have characteristic smell and burn with luminous flame.
4. Unlike alkanes, they show weakly polar properties because of  $\text{sp}^2$  hybridization.

### 8.4.3 Reactivity of a $\pi$ -bond

In the formation of a  $\pi$ -bond, the partially filled p-orbitals overlap in a parallel fashion. The probability of finding electron is thus away from the line joining the two nuclei. Due to this reason  $\pi$ -electrons are less firmly held between the nuclei. A  $\pi$ -bond is, therefore, a weak bond as compared to a  $\sigma$ -bond. During a reaction it breaks comparatively easily rendering alkenes as reactive group of compounds. Moreover, the loosely held  $\pi$ -electrons are more exposed to attack by the electrophilic reagents. Alkenes, therefore, undergo electrophilic reactions very easily.

### 8.4.4 Reactions of Alkenes

#### A. Addition Reactions

##### 1. Addition of Hydrogen (Hydrogenation)

Hydrogenation is a process in which a molecule of hydrogen is added to an alkene in the presence of a catalyst and at moderate pressure (1-5 atm.) to give a saturated compound. The process is known as Catalytic Hydrogenation.

It is a highly exothermic process and the amount of heat evolved when one mole of an alkene is hydrogenated is called Heat of Hydrogenation. The heat of hydrogenation of most alkenes is about  $120\text{kJmol}^{-1}$  for each double bond present in a molecule. The catalysts employed are Pt, Pd and Raney nickel.

#### Raney Nickel

It is prepared by treating a Ni—Al alloy with caustic soda.



Most alkenes are hydrogenated over Raney nickel at about 100°C and upto 3-atmosphere pressure.

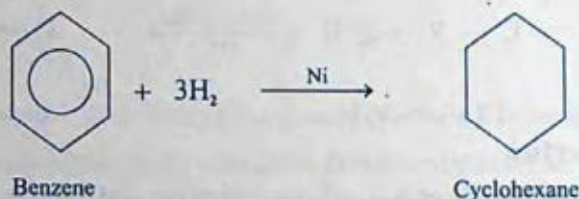
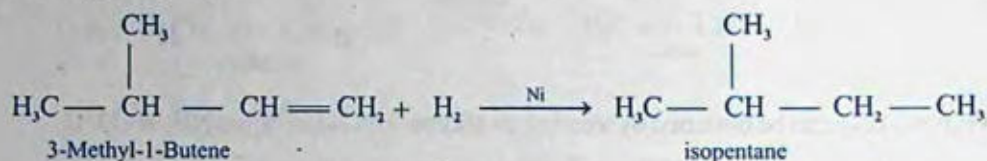

Catalytic hydrogenation of alkenes is used in the laboratory as well as in industry. In industry, it is used for the manufacture of vegetable ghee from vegetable oils. In the laboratory, it is used as a synthetic method as well as an analytical tool, as the reaction is generally quantitative.

## 2. Addition of Hydrogen Halides

Alkenes react with dry gaseous hydrogen halides to form alkyl halides. The order of reactivity of halogen acids is  $\text{HI} > \text{HBr} > \text{HCl}$ .

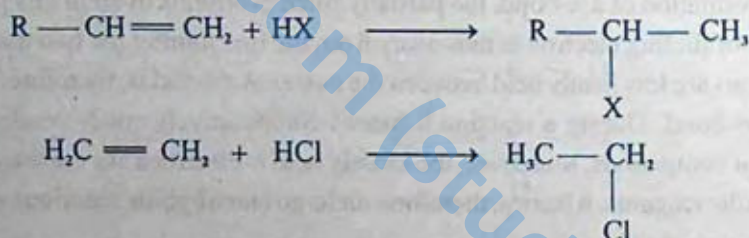

The addition of a hydrogen halide to an alkene takes place in two steps.

Alkene accepts the proton of hydrogen halide to form a carbocation.

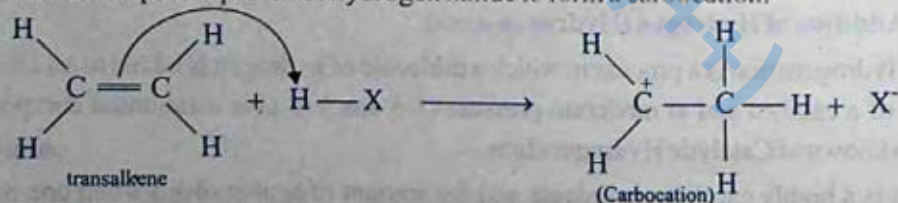

The carbocation then reacts with the halide ion.

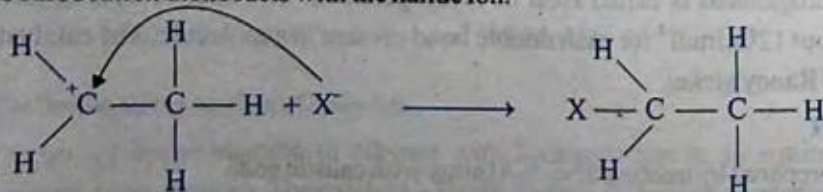

The addition of hydrogen halide over an unsymmetrical alkene is governed by Markownikov's Rule. The rule states that; in the addition of an unsymmetrical reagent to an unsymmetrical alkene, the negative part of the adding reagent goes to that carbon, constituting the double bond, which has least number of hydrogen atoms.

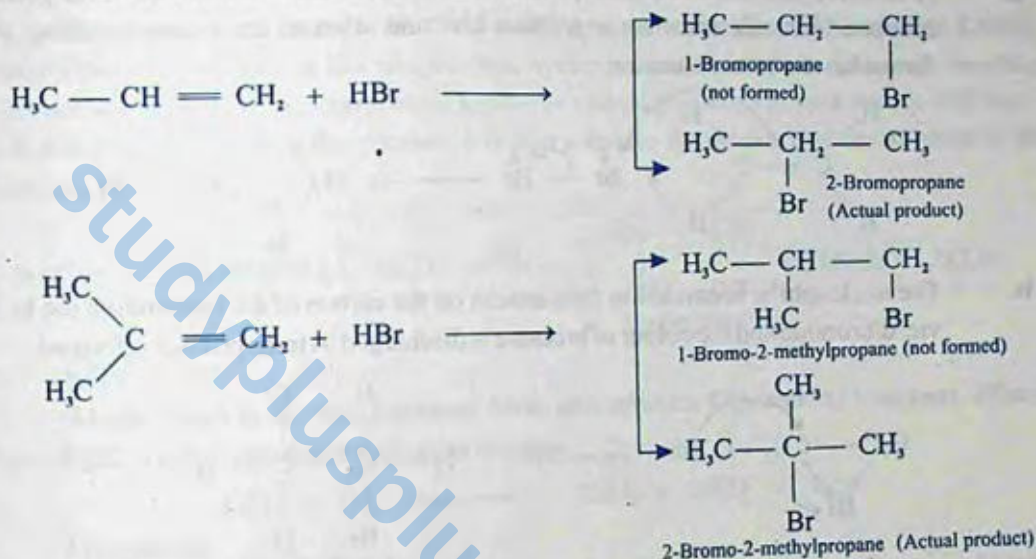

### 3. Addition of Sulphuric Acid

When alkenes are treated with cold concentrated sulphuric acid, they are dissolved because they react by addition to form alkyl hydrogen sulphate. For example,

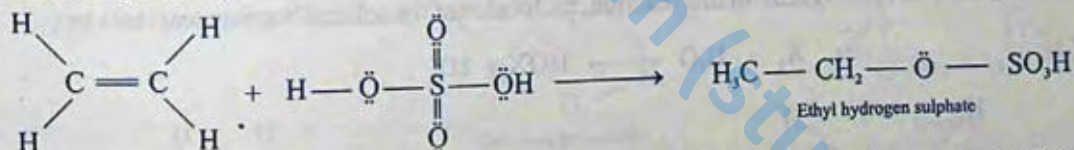

These alkylhydrogen sulphates on boiling with water decompose to give corresponding alcohols. The overall reaction involves the addition of water to an alkene and it is, therefore, called hydration reaction.

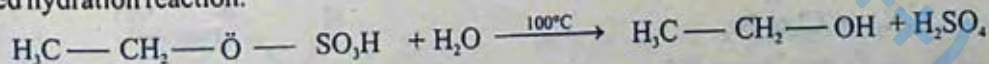

### 4. Addition of Halogens

The alkenes on treatment with halogen in an inert solvent like carbon tetrachloride at room temperature give vicinal dihalides or 1,2 dihalogenated products. For example,

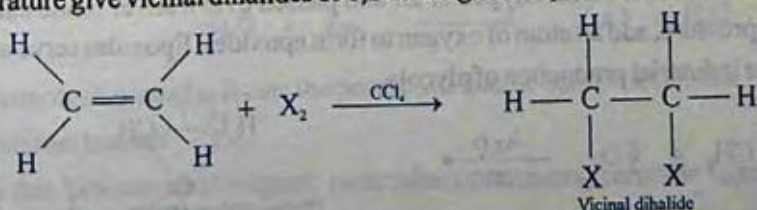

$\text{Br}_2$  and  $\text{Cl}_2$  are effective electrophilic reagents. Fluorine is too reactive to control the reaction. Iodine does not react.

### Mechanism:

- a. A bromine molecule becomes polarized as it approaches the alkene. This polarized bromine molecule transfers a positive bromine atom to the alkene resulting in the formation of a bromonium ion.

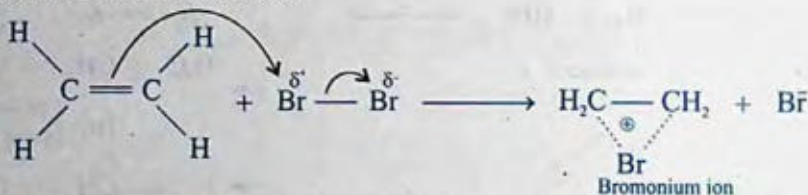

- b. The nucleophilic bromide ion then attacks on the carbon of the bromonium ion to form vic. dibromide and the colour of bromine is discharged. A trans product is formed.



This test is used for the detection of a double bond.

### 5. Addition of Hypohalous acid (HOX)

If the halogenation of an alkene is carried out in an aqueous solution, haloalcohol is formed called a Halohydrin. In this reaction, molecules of the solvent become reactants too.

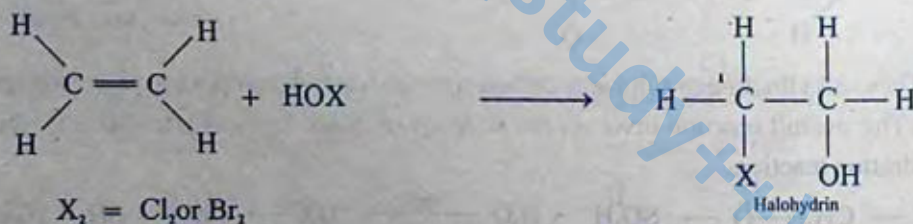

## B. OXIDATION REACTIONS

### 1. Addition of Oxygen

Alkenes when mixed with oxygen or air and passed over a silver oxide catalyst at high temperature and pressure, add an atom of oxygen to form epoxides. Epoxides serve as the starting substances for the industrial production of glycols.

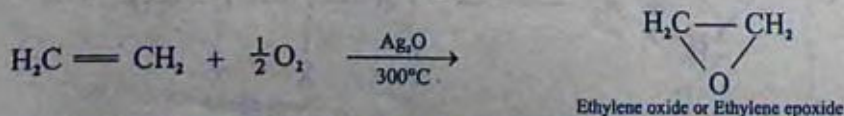

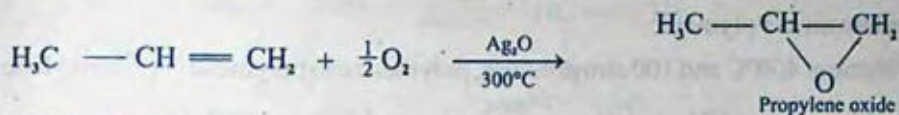

## 2. Hydroxylation

When alkenes are treated with mild oxidizing reagents like dilute (1%) alkaline  $\text{KMnO}_4$  solution (Baeyer's Reagent) at low temperature, hydroxylation of double bond occurs resulting in the formation of dihydroxy compounds known as vicinal glycols. The pink colour of  $\text{KMnO}_4$  solution is discharged during the reaction. It is also a test for the presence of unsaturation in the molecules. For example,

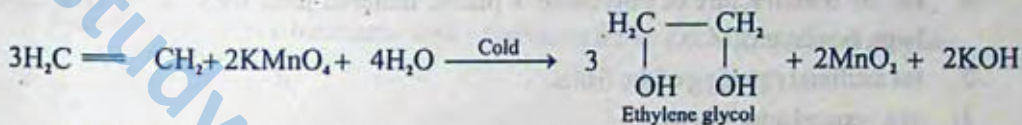

## 3. Combustion

Alkenes burn in air with luminous flame and produce  $\text{CO}_2$  and  $\text{H}_2\text{O}$  vapours. Ethene forms a highly explosive mixture with air or oxygen.



## 4. Ozonolysis

Ozone ( $\text{O}_3$ ) is a highly reactive allotropic form of oxygen. It reacts vigorously with alkenes to form unstable molozonide. It rearranges spontaneously to form an ozonide.

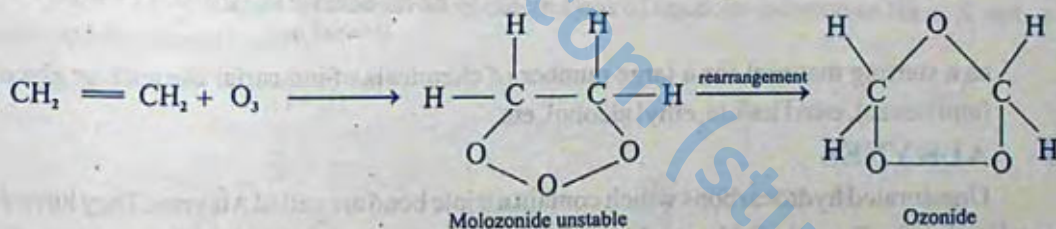

Ozonides are unstable compounds and are reduced directly by treatment with zinc and  $\text{H}_2\text{O}$ . The reduction produces carbonyl compounds (aldehydes or ketones).

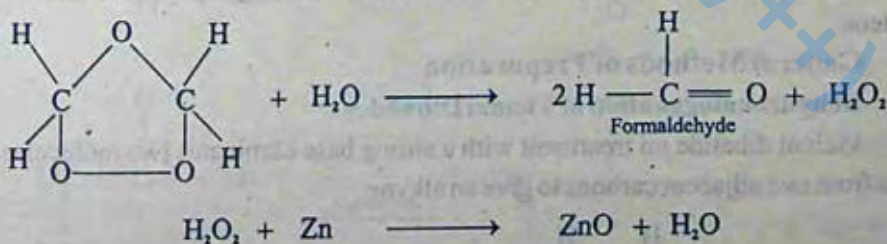

Ozonolysis is used to locate the position of double bond in an alkene.

## C. Polymerization

In this 'process small organic molecules (monomers) combine together to form larger

molecules known as Polymers.

Ethene at 400°C and 100 atm pressure, polymerize to polythene or polyethylene.

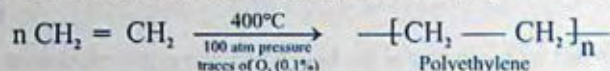

A good quality polythene is obtained, when ethene is polymerized in the presence of aluminium triethyl  $\text{Al}(\text{C}_2\text{H}_5)_3$ , and titanium tetrachloride catalysts ( $\text{TiCl}_4$ ).

#### 8.4.5 Uses of Ethene:

Ethene is used:

1. for the manufacture of polythene, a plastic material used for making toys, cables, bags, boxes, etc.
2. for artificial ripening of the fruits.
3. as a general anaesthetic.
4. for preparing 'Mustard gas' a chemical used in World War I. The name comes from its mustard like odour. It is not a gas, but a high boiling liquid that is dispersed as a mist of tiny droplets. It is a powerful vesicant i.e., causes blisters.

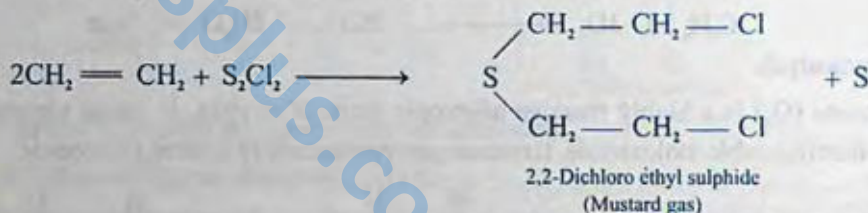

5. as a starting material for a large number of chemicals, of industrial use such as glycols (antifreeze), ethyl halide, ethyl alcohol, etc.

### 8.5 ALKYNES

Unsaturated hydrocarbons which contain a triple bond are called Alkynes. They have the general molecular formula  $\text{C}_n\text{H}_{2n-2}$  and contain two hydrogen atoms less than the corresponding alkenes.

The first member of the Alkyne series has the formula  $\text{C}_2\text{H}_2$  and is known as Ethyne or Acetylene.

#### 8.5.1 General Methods of Preparation

##### 1. Dehydrohalogenation of Vicinal Dihalides

Vicinal dihalide on treatment with a strong base eliminates two molecules of hydrogen halides from two adjacent carbons to give an alkyne.

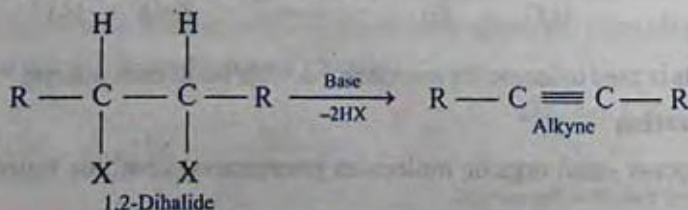



The second molecule of hydrogen halide is removed with great difficulty and requires drastic conditions.

## 2. Dehalogenation of Tetrahalides

Tetra haloalkanes on treatment with active metals like Zn, Mg, etc. form alkynes.

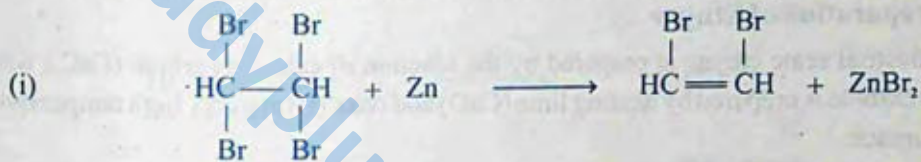

## 3. Electrolysis of Salts of Unsaturated Dicarboxylic Acids

Kolbe's electrolytic method involves electrolysis of aqueous solution of Na or K salts of unsaturated dicarboxylic acids.

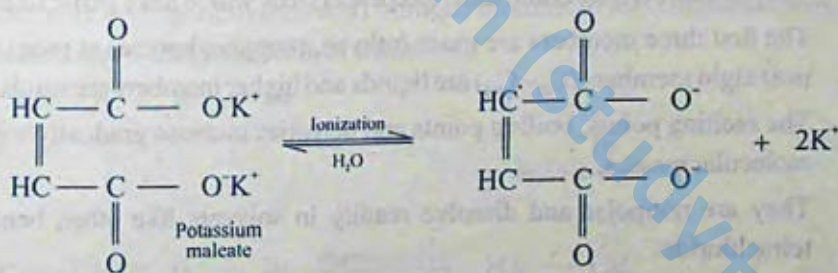

At Anode

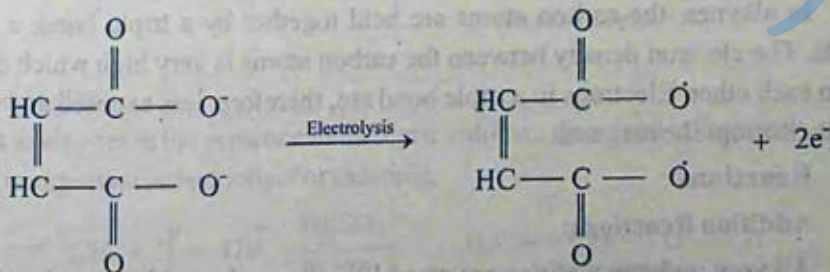

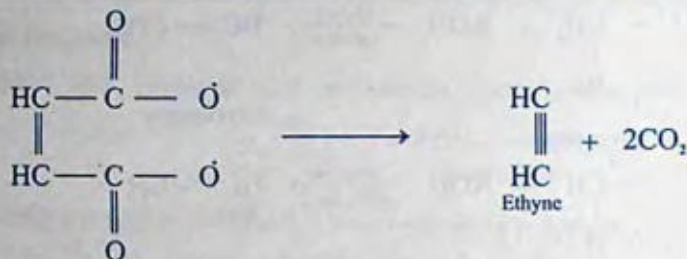
**At Cathode****Industrial Preparation of Ethyne**

On industrial scale ethyne is prepared by the reaction of calcium carbide ( $\text{CaC}_2$ ) with water. Calcium carbide is prepared by heating lime ( $\text{CaO}$ ) and coke ( $\text{C}$ ) at a very high temperature in an electric furnace.

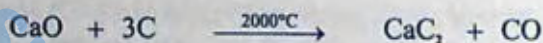
**8.5.2 Physical Characteristics**

1. They are colourless, odourless, except acetylene which has a garlic like odour,
2. The first three members are gases (ethyne, propyne, butyne) at room temperature. The next eight members ( $\text{C}_5 - \text{C}_{12}$ ) are liquids and higher members are solids.
3. The melting points, boiling points and densities increase gradually with the increase in molecular masses.
4. They are nonpolar and dissolve readily in solvents like ether, benzene and carbon tetrachloride.

**8.5.3 Reactivity of Alkynes**

In alkynes, the carbon atoms are held together by a triple bond, a  $\sigma$ -bond and two  $\pi$ -bonds. The electron density between the carbon atoms is very high which draws atoms very close to each other. Electrons in a triple bond are, therefore, less exposed and thus less reactive towards electrophilic reagents.

**8.5.4 Reactions****A. Addition Reactions:**

Alkynes undergo addition reactions like alkenes but add two molecules of the reagent instead of one.



bonded carbon atom and isomerises to acetaldehyde.



All other alkynes give ketones.

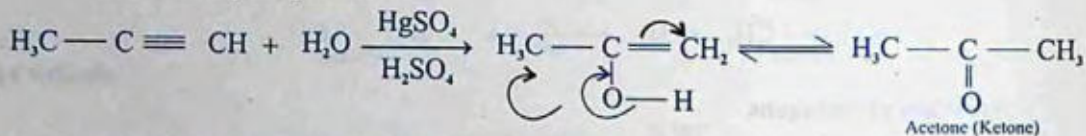

### 5. Addition of Ammonia and Hydrogen Cyanide:

$\text{NH}_3$  and  $\text{HCN}$  react with ethyne in the presence of suitable catalysts, to give nitriles.

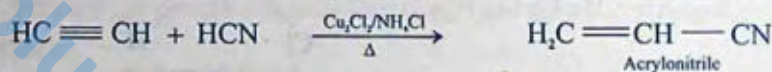
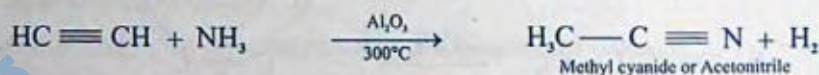

### B. Oxidation Reactions

1. Ethyne on oxidation with strong alkaline  $\text{KMnO}_4$ , gives glyoxal.

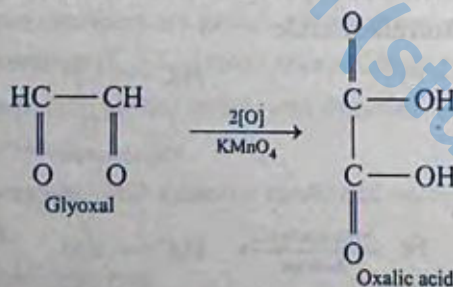
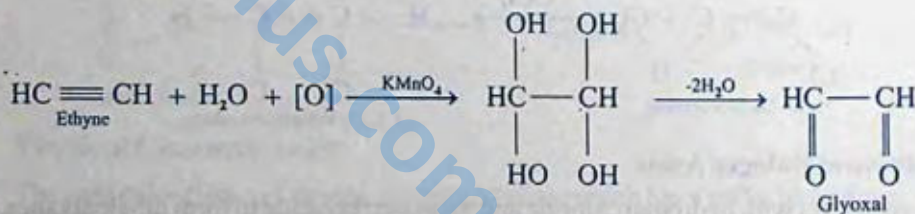

2. **Combustion:**

Alkynes when burnt in air or oxygen produce heat and evolves  $\text{CO}_2$  and  $\text{H}_2\text{O}$ . The reaction is highly exothermic for acetylene and the resulting oxyacetylene flame is used for welding and cutting of metals.



C. **Polymerization**

Alkynes polymerize to give linear or cyclic compounds depending upon the temperature

and catalyst used. However, these polymers are different from the polymers of the alkenes as they are usually low molecular weight polymers.

### 1. Conversion of Acetylene to Divinyl Acetylene

When acetylene is passed through an acidic solution of cuprous chloride and ammonium chloride and then allowed to stand for several hours at room temperature, vinyl acetylene and divinyl acetylene are obtained.

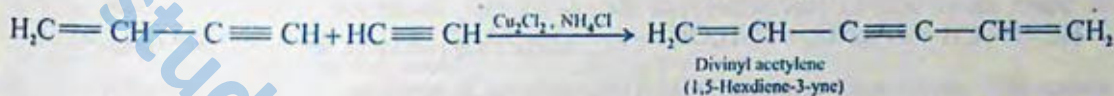
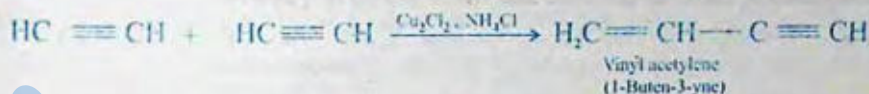

If HCl is added to vinyl acetylene, chloroprene is obtained which readily polymerizes to neoprene, used as synthetic rubber.

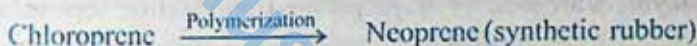
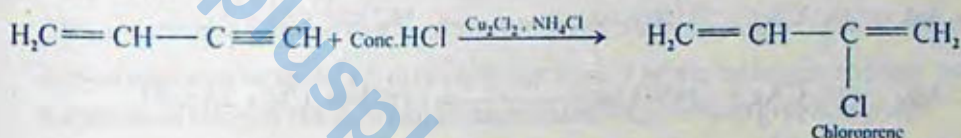

### 2. Conversion of Acetylene to Benzene

When acetylene is passed through a copper tube at 300°C, it polymerizes to benzene.

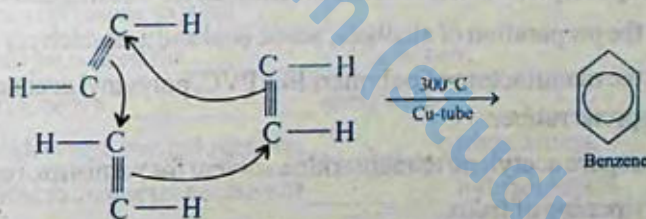

### D. Acidic Nature of Alkynes

In ethyne and other terminal alkynes like propyne, the hydrogen atom is bonded to the carbon atom with  $sp$ - $s$  overlap. An  $sp$  hybrid orbital has 50%  $s$ -character in it and renders the carbon atom more electronegative than  $sp^2$  and  $sp^3$  hybridized carbons. As a result, the  $sp$  hybridized carbon atom of a terminal alkyne pulls the electrons more strongly making the attached hydrogen atom slightly acidic.



When 1-alkyne or ethyne is treated with sodamide in liquid ammonia or passed over molten sodium, alkynides or acetylides are obtained.

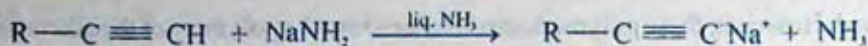

Sodium acetylide is a very valuable reagent for chemical synthesis and is essentially ionic in nature. Acetylides of copper and silver are obtained by passing acetylene in the ammoniacal solution of cuprous chloride and silver nitrate respectively.



Silver and copper acetylides react with acids to regenerate alkynes.



These alkynides are used for the preparation, purification, separation, and identification of alkynes.

### 8.5.5 Uses of Ethyne

Ethyne is used:

1. in oxyacetylene torch which is in turn used for welding and cutting metals.
2. for the preparation of alcohols, acetic acid and acetaldehyde.
3. for the manufacture of polymers like PVC, polyvinyl acetate, polyvinyl ethers, orlon and neoprene rubber.
4. to prepare acetylene tetrachloride a solvent for varnishes, resins, and rubber.
5. for ripening of fruits.

### 8.5.6 Comparison of Reactivities of Alkanes, Alkenes and Alkynes

The general decreasing reactivity order of alkanes, alkenes and alkynes is as follows:

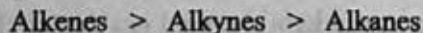

It has already been explained that a  $\pi$ -bond in alkenes is not only weak but its electrons are more exposed to an attack by an electrophilic reagent. Both these facts make the alkenes a very reactive class of compounds. Alkynes although contain two  $\pi$ -bonds are less reactive than alkenes towards electrophilic reagents. This is because the bond distance between the two triple bonded carbon atoms is very short and hence the  $\pi$ -electrons are not available to be attacked by electrophilic reagents. Alkynes are, however, more reactive than alkenes towards nucleophilic reagents.

## KEY POINTS

1. Hydrocarbons are made up of carbon and hydrogen only. Saturated hydrocarbons are called alkanes. They do not contain functional groups.
2. Alkanes react with halogens by a free radical mechanism to give haloalkanes. This mechanism consists of three steps, initiation, propagation and termination.
3. Alkenes are unsaturated hydrocarbons with at least one C=C. The double bond is composed of a  $\sigma$  and a  $\pi$  bond. Carbon atoms in alkenes are  $sp^2$  hybridized.
4. Alkenes are very reactive compounds. They undergo electrophilic reactions very easily.
5. Addition of unsymmetrical reagent to an unsymmetrical alkene takes place in accordance with the Markownikov's rule.
6. Alkenes can be very easily oxidized with cold  $KMnO_4$  solution,  $O_3$  or ozone. With ozone both the bonds between carbon atoms are cleaved.
7. Hydrocarbons containing a triple bond are known as alkynes or acetylenes.
8. Alkynes undergo addition reactions and two molecules of a reagent are added in them.
9. Ethyne and other terminal alkynes contain a weakly acidic hydrogen and they react with ammoniacal cuprous chloride and ammoniacal silver nitrate to give acetylides.
10. The decreasing reactivity order of alkanes, alkenes and alkynes is as follows:

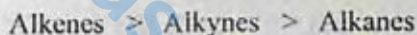

## EXERCISE

Q.1. Fill in the blanks.

1. Ozone reacts with ethene to form \_\_\_\_\_.
2. Lindlar's catalyst is used for \_\_\_\_\_ of alkynes.
3. Divinyl acetylene is a \_\_\_\_\_ acetylene.
4. Vicinal dihalides have two halogens on \_\_\_\_\_ carbon atoms.
5. Ethyne is acidic in character because of \_\_\_\_\_ hybridization.
6. Halohydrins are formed due to addition of \_\_\_\_\_ in ethene.
7. Ethylene glycol is produced when \_\_\_\_\_ reacts with cold alkaline  $KMnO_4$  solution.
8. Mustard gas is a high boiling \_\_\_\_\_.
9. Ethyne has \_\_\_\_\_ like odour.
10. Ethyne is obtained by the reaction of \_\_\_\_\_ with calcium carbide.

Q.2. Indicate True or False.

1. Addition of HX to unsymmetrical alkanes takes place according to Markownikov's rule.
2. Methane reacts with bromine water and its colour is discharged.

3. Mustard gas is a blistering agent.
4. Methane is also called marsh gas.
5. Ethyne is a saturated compound.
6. Baeyer's reagent is used to locate a double bond in an alkene.
7. Alkanes usually undergo substitution reactions.
8. Benzene is a polymer of ethene.
9. Acrylonitrile can be obtained from ethyne.
10. Ethyne is more reactive towards electrophilic reagents than ethene.

Q. 3. Multiple choice questions. Encircle the correct answer.

i) Preparation of vegetable ghee involves:

- |                   |                     |
|-------------------|---------------------|
| (a) Halogenation  | (b) Hydrogenation   |
| (c) Hydroxylation | (d) Dehydrogenation |

ii) Formula of chloroform is:

- |                            |                    |                              |                     |
|----------------------------|--------------------|------------------------------|---------------------|
| (a) $\text{CH}_3\text{Cl}$ | (b) $\text{CCl}_4$ | (c) $\text{CH}_2\text{Cl}_2$ | (d) $\text{CHCl}_3$ |
|----------------------------|--------------------|------------------------------|---------------------|

iii) The presence of a double bond in a compound is the sign of:

- |                  |                  |
|------------------|------------------|
| (a) Saturation   | (b) Unsaturation |
| (c) Substitution | (d) None         |

iv) Vinyl acetylene combines with HCl to form:

- |                   |                       |
|-------------------|-----------------------|
| (a) Polyacetylene | (b) Benzene           |
| (c) Chloroprene   | (d) Divinyl acetylene |

v) The addition of unsymmetrical reagent to an unsymmetrical alkene is in accordance with the rule:

- |                                 |                        |
|---------------------------------|------------------------|
| (a) Hund's rule                 | (b) Markownikov's rule |
| (c) Pauli's Exclusion Principle | (d) Aufbau Principle   |

vi) Synthetic rubber is made by polymerization of:

- |                       |                 |
|-----------------------|-----------------|
| (a) Chloroform        | (b) Acetylene   |
| (c) Divinyl acetylene | (d) Chloroprene |

vii)  $\beta$ - $\beta'$ -dichloroethyl sulphide is commonly known as:

- |                  |                  |
|------------------|------------------|
| (a) Mustard gas  | (b) Laughing gas |
| (c) Phosgene gas | (d) Bio-gas      |

ix) When methane reacts with  $\text{Cl}_2$  in the presence of diffused sunlight the products obtained are:

- |                                       |                               |
|---------------------------------------|-------------------------------|
| (a) Chloroform only                   | (b) Carbon tetrachloride only |
| (c) Chloromethane and dichloromethane | (d) Mixture of a, b, c        |



- Q.10. (a) What is meant by octane number? Why does a high octane fuel has a less tendency to knock in an automobile engine?
- (b) Explain free radical mechanism for the reaction of chlorine with methane in the presence of sunlight.

Q.11. (a) Write structural formulas for each of the following compounds.

- |                        |                                   |
|------------------------|-----------------------------------|
| i) Isobutylene         | ii) 2,3,4,4-Tetramethyl-2-pentene |
| iii) 2,5-Heptadiene    | iv) 4,5-Dimethyl-2-hexene         |
| v) Vinyl-acetylene     | vi) 1,3-Pentadiene                |
| vii) 1-Butyne          | viii) 3-n-Propyl-1,4-pentadiene   |
| ix) Vinyl bromide      | x) But-1-en-3-yne                 |
| xi) 4-Methyl-2-pentyne | xii) Isopentane                   |

(b) Name the following compounds by IUPAC system.

- |   |   |
|---|---|
| (i) $\text{H}_3\text{C}-\text{CH}=\text{CH}(\text{CH}_2)_2\text{CH}_3$                                | (ii) $(\text{CH}_3)_2\text{C}=\text{CH}_2$                                  |
| (iii) $\text{CH}_3-\text{CH}_2-\text{CH}_2-\underset{\text{CH}(\text{CH}_3)_2}{\text{C}}=\text{CH}_2$ | (iv) $\text{CH}_2=\text{CH}-\text{CH}=\text{CH}_2$                          |
| (v) $\text{CH}_2=\underset{\text{C}_2\text{H}_5}{\text{C}}-\text{CH}_2\text{CH}_2\text{CH}_3$         | (vi) $\text{CH}\equiv\text{C}-\text{CH}_3$                                  |
| (vii) $\text{CH}_3-\text{C}\equiv\text{C}-\text{CH}_3$  | (viii) $\text{CH}_2=\text{CH}-\text{C}\equiv\text{C}-\text{CH}=\text{CH}_2$ |
| (ix) $\text{CH}\equiv\text{C}-\text{CH}=\text{CH}-\text{C}\equiv\text{CH}$                            | (x) $\text{CH}_2=\text{CH}-\text{C}\equiv\text{CH}$                         |

Q.12. (a) Describe different methods for the preparation of alkenes. How would you establish that ethylene contains a double bond?

(b) Give structure formulas of the alkenes expected to form by the dehydrohalogenation of the following compounds with a strong base:

- |                                     |                              |
|-------------------------------------|------------------------------|
| i) 1-Chloropentane                  | ii) 2-Chloro-3-methyl butane |
| iii) 1-Chloro-2,2-dimethyl propane. |                              |

Q.13. (a) Write down chemical equations for the preparation of propene from the following compounds.

- |  |   |
|--|---|
| i) $\text{CH}_3-\text{CH}_2-\text{CH}_2-\text{OH}$ | ii) $\text{CH}_3-\text{C}\equiv\text{CH}$ |
| iii) iso-Propyl chloride                           |   |

(b) Write skeleton formula showing only the arrangement of carbon atoms for all the possible alkenes of the molecular formula  $\text{C}_6\text{H}_{12}$ .

Q.14. (a) How may ethene be converted into ethyl alcohol?

- (b) Starting from ethene, outline the reactions for the preparation of following compounds.  
 i) 1,2-Dibromoethane    ii) Ethyne    iii) Ethane    iv) Ethylene glycol
- (c) How will you bring about the following conversions?  
 i) 1-Butene to 1-Butyne    ii) 1-Propanol to  $\text{CH}_3\text{—CH—CH}_2\text{Cl}$

Q. 15. Show by means of chemical equations how the following cycle of changes may be affected.

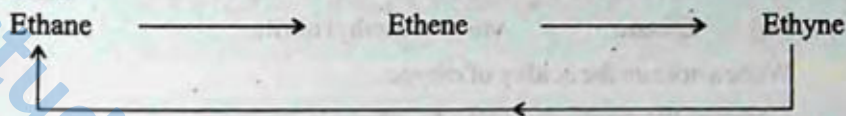

Q. 16. Write down structural formulas for the products that are formed when 1-butene will react with the following reagents:

- |  |                                     |
|--|-------------------------------------|
| i) $\text{H}_2, \text{Pt}$                     | ii) $\text{Br}_2$ in $\text{CCl}_4$ |
| iii) Cold dil. $\text{KMnO}_4/\text{OH}$       | iv) $\text{HBr}$                    |
| v) $\text{O}_2$ in the presence of $\text{Ag}$ | vi) $\text{HOCl}$                   |
| vii) dil. $\text{H}_2\text{SO}_4$              |                                     |

Q. 17. In the following reactions, identify each lettered product.

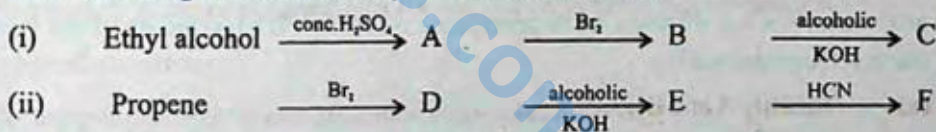

Q. 18. After an ozonolysis experiment, the only product obtained was acetaldehyde  $\text{CH}_3\text{CHO}$ . Can you give the structural formula of this compound?

Q. 19. (a) The addition of sulphuric acid to an alkene obeys Markownikov's rule. Predict the structures of the alcohols obtained by the addition of the acid to the following compounds.

- i) Propene    ii) 1-Butene    iii) 2-Butene

(b) Predict the most likely product of the addition of hydrogen chloride to 2-methyl-2-butene. Explain the formation of this product.

Q. 20. Why are some hydrocarbons called saturated and others unsaturated? What type of reactions are characteristics of them?

Q. 21. (a) Describe methods for the preparation of Ethyne.

(b) How does ethyne react with:

- |                               |  |
|-------------------------------|--|
| i) Hydrogen                   | ii) Halogen acid   |
| iii) Alkaline $\text{KMnO}_4$ | iv) 10% $\text{H}_2\text{SO}_4$ in the presence of $\text{HgSO}_4$ |
| v) Ammonical cuprous chloride |  |

- (c) Mention some important uses of methane, ethene and ethyne.
- Q.22. Describe how you could distinguish ethane, ethene and ethyne from one another by means of chemical reactions.
- Q.23. (a) How will you synthesize the following compounds starting from ethyne.
- |                  |                      |
|------------------|----------------------|
| i) Acetaldehyde  | ii) Benzene          |
| iii) Chloroprene | iv) Glyoxal          |
| v) Oxalic acid   | vi) Acrylonitrile    |
| vii) Ethane      | viii) Methyl nitrile |
- (b) Write a note on the acidity of ethyne.
- Q.24. (a) Compare the reactivity of ethane, ethene and ethyne.  
 (b) Compare the physical properties of alkanes, alkenes and alkynes.
- Q.25. How does propyne react with the following reagents.
- |  |
|--|
| (a) $\text{AgNO}_3/\text{NH}_4\text{OH}$                     |
| (b) $\text{Cu}_2\text{Cl}_2/\text{NH}_4\text{OH}$            |
| (c) $\text{H}_2\text{O}/\text{H}_2\text{SO}_4/\text{HgSO}_4$ |
- Q.26. A compound has a molecular formula  $\text{C}_4\text{H}_6$ , when it is treated with excess hydrogen in the presence of Ni-catalyst, a new compound  $\text{C}_4\text{H}_{10}$  is formed. When  $\text{C}_4\text{H}_6$  is treated with ammoniacal silver nitrate a white precipitate is formed. What is the structural formula of the given compound?
- Q.27. (a) Identify A and B.

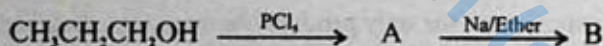

- (b) Give the general mechanism of electrophilic addition reactions of alkenes.

## CHAPTER

## 9

AROMATIC  
HYDROCARBONS

## In this chapter you will learn

1. To name simple aromatic hydrocarbons, and their derivatives.
2. The Kekule and resonance approaches to explain the structure and stability of benzene.
3. About the preparation of benzene.
4. About the electrophilic substitution, oxidation and addition reactions of benzene.
5. About the isomerism which arises when a second substituent enters the ring.
6. How does the presence of a group alter the reactivity of benzene ring towards electrophilic substitution reactions.
7. The comparison of reactivities of alkanes, alkenes and benzene.

## 9.1 INTRODUCTION

The term **aromatic** was derived from the Greek word 'aroma' meaning "fragrant" and was used in Organic Chemistry for a special class of compounds. These compounds have a low hydrogen to carbon ratio in their molecular formula and have a characteristic odour. However, it was soon realized that many aromatic compounds are odourless whereas many others are fragrant though they are not aromatic. Further, when aromatic compounds of higher molecular mass were subjected to various methods of degradation, they often produced benzene or derivatives of benzene. It was observed that almost all the aromatic compounds have a six carbon unit in their molecules like benzene. Hence, benzene was recognized as the simplest and the parent member of this class of compounds.

So aromatic hydrocarbons include benzene and all those compounds that are structurally related to benzene.

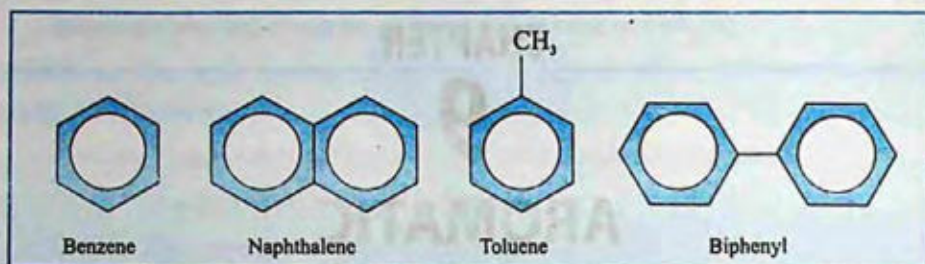

It appears from the definition of aromatic hydrocarbons that any study of this class of compounds must begin with the study of benzene. Benzene has characteristic structural features. It has a regular planar hexagonal structure. On the basis of the number of benzene rings aromatic hydrocarbons can be categorized into following classes.

- a. Monocyclic Aromatic Hydrocarbons and their derivatives
  - b. Polycyclic Aromatic Hydrocarbons
- a. **Monocyclic Aromatic Hydrocarbons and their Derivatives**

Aromatic hydrocarbons containing one benzene ring in their molecules are called Monocyclic Aromatic Hydrocarbons, e.g. benzene and its derivatives.

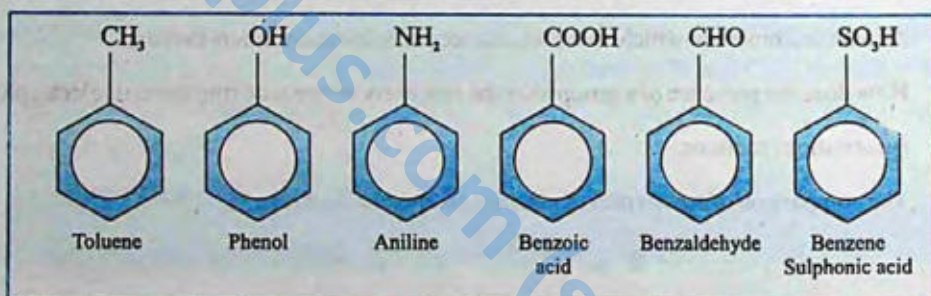

b. **Polycyclic Aromatic Hydrocarbons**

Aromatic hydrocarbons containing two or more benzene rings in their molecules are called Polycyclic Aromatic Hydrocarbons. They may be divided into two main classes.

- (i) Those in which benzene rings are isolated, e.g. biphenyl, diphenylmethane, etc.

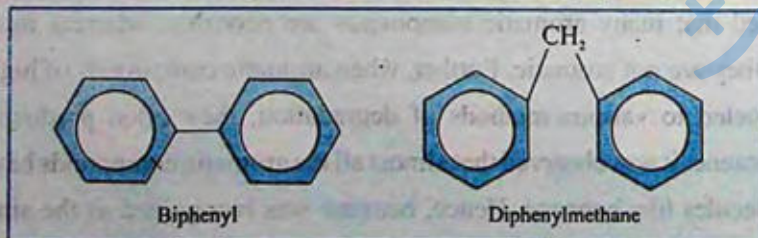

- (ii) Those in which the benzene rings are fused together at ortho positions so that the adjacent rings have a common carbon to carbon bonds, e.g. naphthalene, phenanthrene and anthracene.

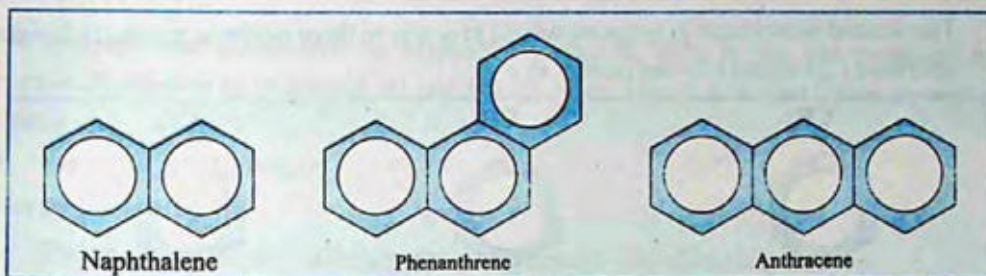

## 9.2 NOMENCLATURE

### (Monocyclic Aromatic Hydrocarbons and their Derivatives)

The nomenclature of the aromatic hydrocarbons is much more complex than that of aliphatic hydrocarbons.

The system used for naming benzene and its derivatives generally depends on the number of substituents on the benzene ring. Some important rules of naming are given below.

1. Mono-substituted benzene derivatives are named by prefixing benzene with the name of the substituent. The whole name is written as one word, e.g.

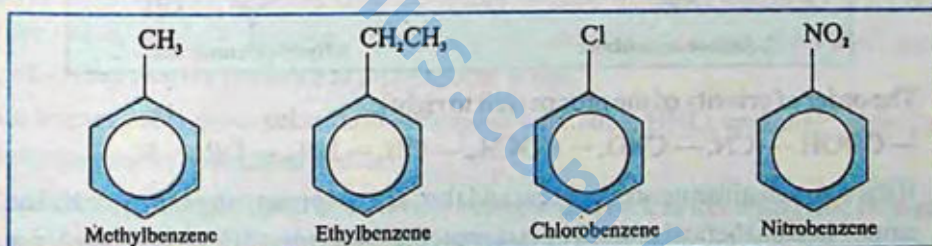

2. There are certain monosubstituted benzene derivatives which are given the special names, like methylbenzene as toluene, hydroxybenzene as phenol etc.

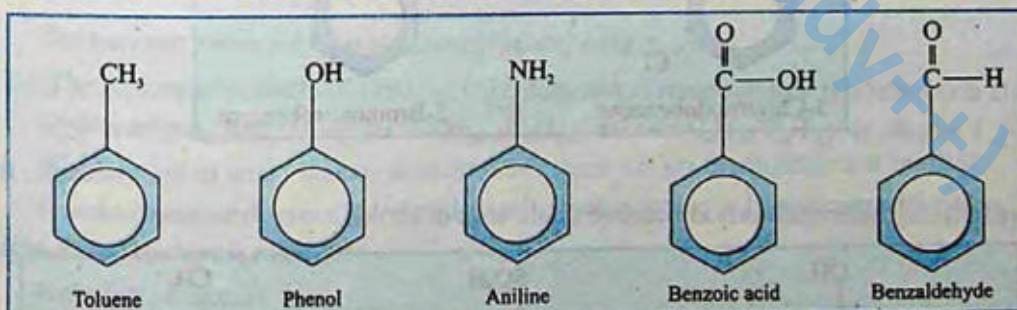

All the six positions in benzene are exactly equivalent so there is only one monosubstituted benzene.

When a hydrogen atom is removed from benzene, we get a phenyl group symbolized by  $\text{C}_6\text{H}_5-$  or  $\text{Ph}-$ . Substituted phenyl groups are called aryl groups.

3. The second substituent in benzene would give rise to three isomeric products designated as ortho (1,2), meta(1,3) and para(1,4), e.g.

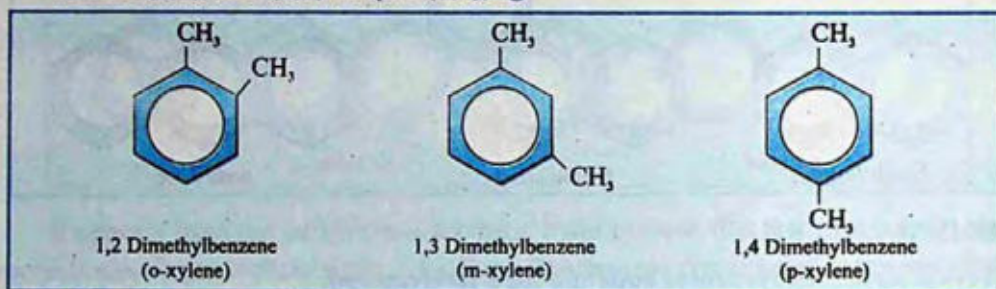

4. If two or more substituents are different, then the substituent that is treated as a high priority group, is given the number 1 position in the benzene ring. Other groups are numbered by counting from position 1 in the manner which gives them the lowest number.

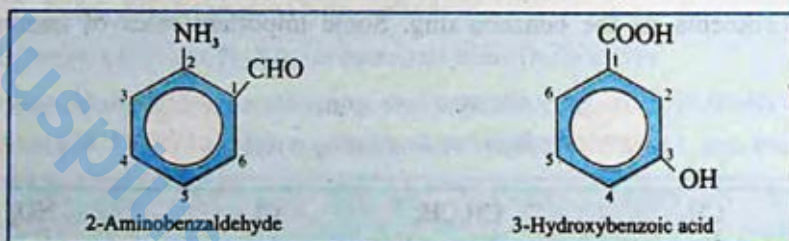

The order of priority of the groups (left to right):

—COOH, —CN, —CHO, —COCH<sub>3</sub>, —OH, —NH<sub>2</sub>, —OR, —R,

5. If the two substituents are different and they are not present in priority order list, they are named in alphabetical order. The last named substituent will be at position 1, e.g.,

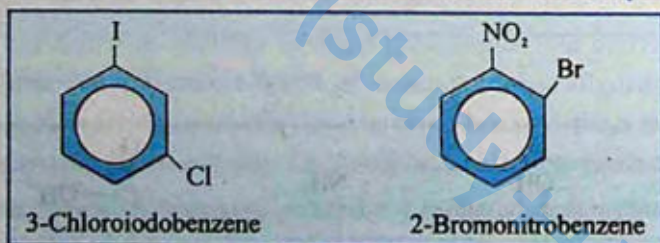

6. If there is a substituent on the ring which gives a special name to the molecule, then special name is used as parent name to the molecule, e.g.



## 9.3 BENZENE

Benzene was discovered by Michael Faraday in 1825 in the gas produced by the destructive distillation of vegetable oil and twenty years later it was also found in coal-tar by Hoffmann.

### 9.3.1 Structure of Benzene

#### Molecular Formula

- The empirical formula of benzene is determined by the elemental analysis.
- Its molecular mass determined by the vapour density method is 78.108. This is six times the empirical formula mass ( $\text{CH} = 12 + 1 = 13$ ). Therefore, the molecular formula of benzene is  $\text{C}_6\text{H}_6$ .
- The molecular formula of benzene indicates that it is highly unsaturated compound.

### 9.3.2 Straight Chain Structures Ruled Out:

- Two of the possible straight chain formulas suggested for benzene are :

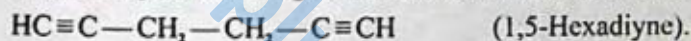

A compound having a structure as above should behave like an alkene or alkyne, both are oxidized by alkaline  $\text{KMnO}_4$  solution. On the contrary, benzene is stable to  $\text{KMnO}_4$  solution i.e. it does not decolorize  $\text{KMnO}_4$  solution. Benzene gives addition reactions with hydrogen and halogens, which indicate the presence of three double bonds.

But benzene also gives substitution reactions with conc.  $\text{HNO}_3$  and conc.  $\text{H}_2\text{SO}_4$ , which indicate that benzene has a saturated structure.

- Considering a straight chain structure for benzene and further assuming that each carbon carries one H-atom, it should be capable of forming three monosubstitution products.



But benzene yields only one monosubstituent product.

- The molecular formula of benzene  $\text{C}_6\text{H}_6$  does not correspond to any of the open chain hydrocarbons, such as alkane  $\text{C}_n\text{H}_{2n+2}$  ( $\text{C}_6\text{H}_{14}$ ), alkene  $\text{C}_n\text{H}_{2n}$  ( $\text{C}_6\text{H}_{12}$ ) or alkyne  $\text{C}_n\text{H}_{2n-2}$  ( $\text{C}_6\text{H}_{10}$ ).

It means benzene does not belong to open chain hydrocarbon and therefore possibility of a straight chain structure is ruled out.

### 9.3.3 Kekule's Structure

The structure of benzene continued to be a serious problem for chemists for about 40 years. A German chemist, Kekule at last solved the problem in 1865. Kekule proposed a cyclic regular hexagonal structure for benzene, which contains three double bonds alternating with three single bonds.

He supported his theory by the following arguments.

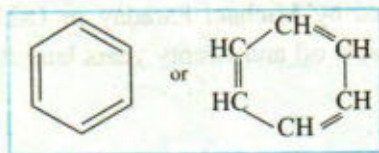

- (i) Benzene gives only one monosubstituted product.

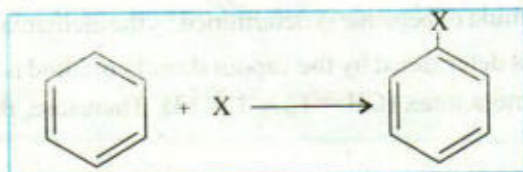

- (ii) Benzene gives only three disubstituted products.

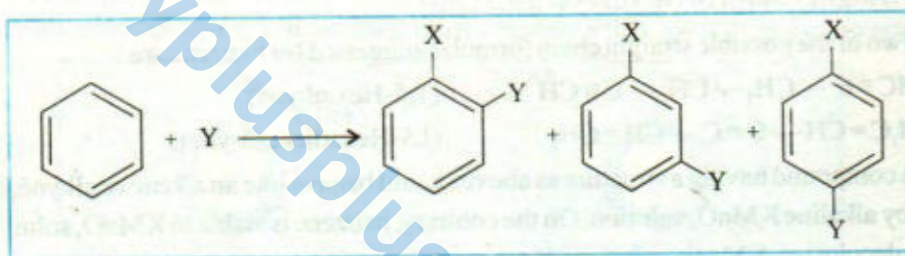

These points confirm the regular hexagonal structure for benzene in which all the carbon atoms are occupying identical positions in the molecule. Therefore, benzene forms only one toluene, one phenol and one nitrobenzene.

- (iii) Benzene adds three hydrogen molecules in the presence of a catalyst.

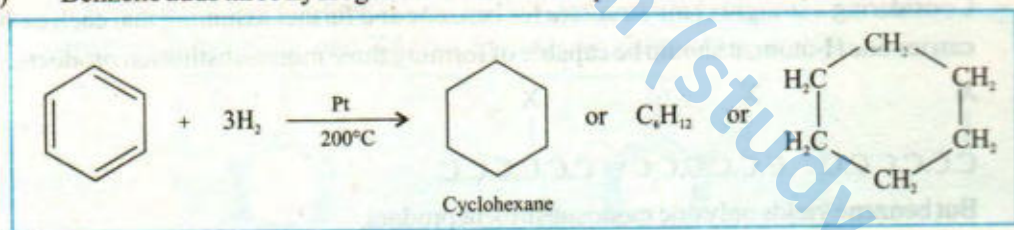

- (iv) Benzene adds three molecules of chlorine in the presence of sunlight.

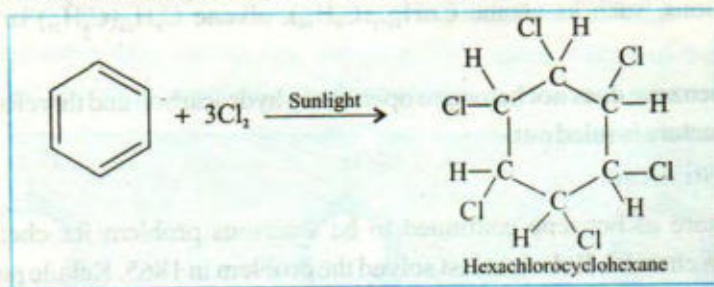

These two reactions confirm the presence of three double bonds alternating with three single bonds.

### 9.3.4 X-Ray Studies of Benzene Structure

The X-ray studies of benzene have confirmed the hexagonal structure for it. These studies have also revealed that all the carbon and hydrogen atoms are in the same plane. All the angles are of  $120^\circ$ . All C–C and C–H bond lengths are 1.397 Å and 1.09 Å, respectively.

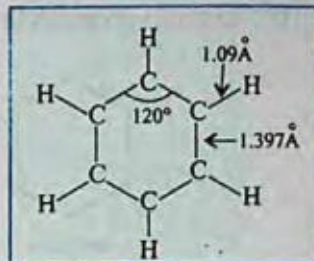

### Objections to Kekule's Formula

Kekule's formula with three double bonds demands a high degree of unsaturation from benzene while usually it exhibits a saturated character. Thus benzene yields substitution products readily and forms addition products reluctantly. Benzene is also a very stable compound. All these properties of benzene can be easily explained using the modern theories about its structure.

### 9.3.5 Modern Concepts About the Structure of Benzene

#### Atomic Orbital Treatment of Benzene

The hexagonal frame-work of benzene can be conveniently explained using hybridization approach. According to this, each carbon in benzene is  $sp^2$  hybridized. The three  $sp^2$  hybrid orbitals on each carbon are utilized to form three  $\sigma$ -bonds, two with adjacent carbon atoms and one with hydrogen. The unhybridized  $2p_z$  orbitals remain at right angle to these  $sp^2$  orbitals. Since all the  $sp^2$  orbitals are in the same plane therefore all the carbon and hydrogen atoms are coplanar. All the angles are of  $120^\circ$  which confirms the regular hexagonal structure of benzene.

The unhybridized  $2p_z$  orbitals partially overlap to form a continuous sheath of electron cloud, enveloping, above and below, the six carbon-carbon sigma bonds of the ring. Since each  $2p_z$  orbital is overlapped by the  $2p_z$  orbitals of adjacent carbon atoms, therefore, this overlapping gives, 'diffused' or 'delocalized' electron cloud.

### 9.3.6 The Stability of Benzene

As mentioned earlier benzene is an extraordinary stable molecule. This stability is due to the extensive delocalization of electron cloud. The extent of stability of benzene can be measured by comparing it with hypothetical compound, 1,3,5-cyclohexatriene. This can be done by estimating their heats of hydrogenation.

Cyclohexene, a six membered ring containing one double bond, can be easily hydrogenated to give cyclohexane. When the  $\Delta H$  for this reaction is measured it is found to be

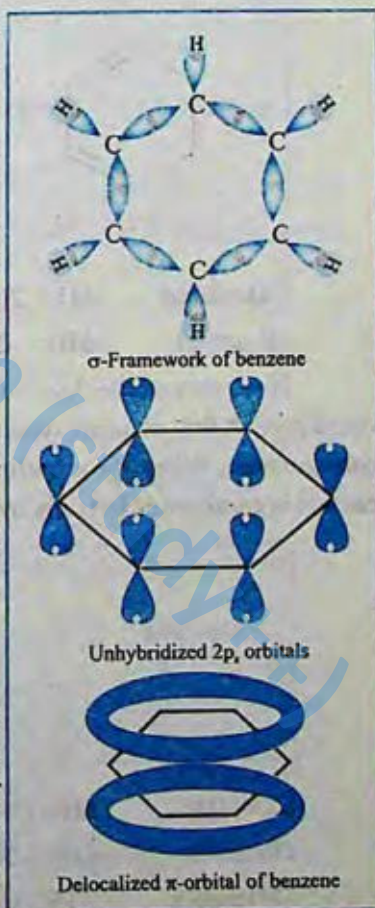

-119.5 kJ/mol, very much like that of any similarly substituted alkene.

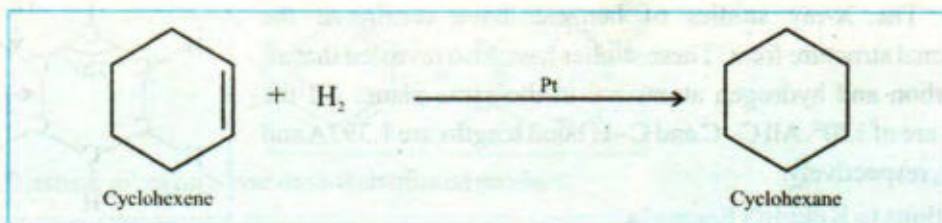

We would expect that hydrogenation of 1,3-cyclohexadiene would liberate roughly twice as much heat and thus have  $\Delta H$  equal to about  $-239$  kJ/mol. When this experiment is done, the result is  $\Delta H = -231.5$  kJ/mol. This result is quite close to what we calculated, and the difference can be explained by taking into account the fact that compounds containing conjugated double bonds are usually somewhat more stable than those containing isolated double bonds.

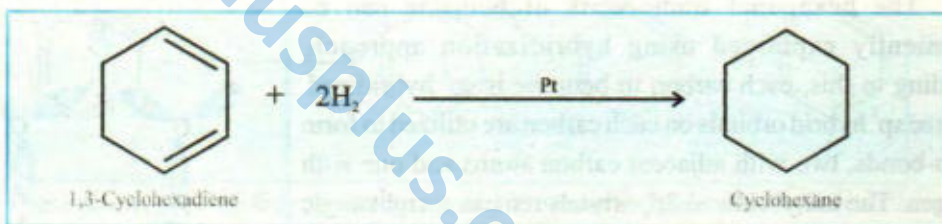

Calculated  $\Delta H = 2(-119.5) = -239$  kJ/mol

Observed  $\Delta H = -231.5$  kJ/mol

If we extend this kind of thinking, and if benzene is simply 1,3,5-cyclohexatriene, we would predict that benzene would liberate approximately  $-358.5$  kJ/mol ( $3 \times -119.5$ ) when it is hydrogenated. When the experiment is actually done the result is surprisingly different. The reaction is exothermic but only by  $-208$  kJ/mol.

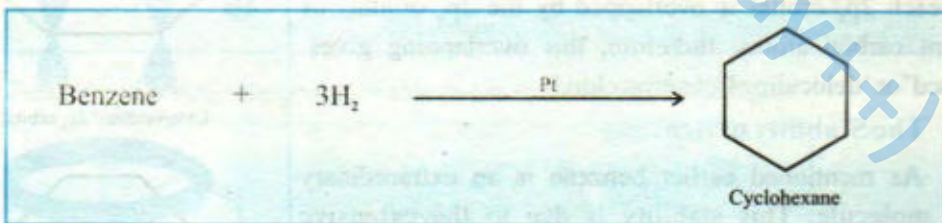

Calculated  $\Delta H = (3 \times -119.5) = -358.5$  kJ/mol

Observed  $\Delta H = -208$  kJ/mol

Difference = 150.5 kJ/mol

When the results are represented by the following figure, it becomes clear that benzene is much more stable than we calculated it to be.

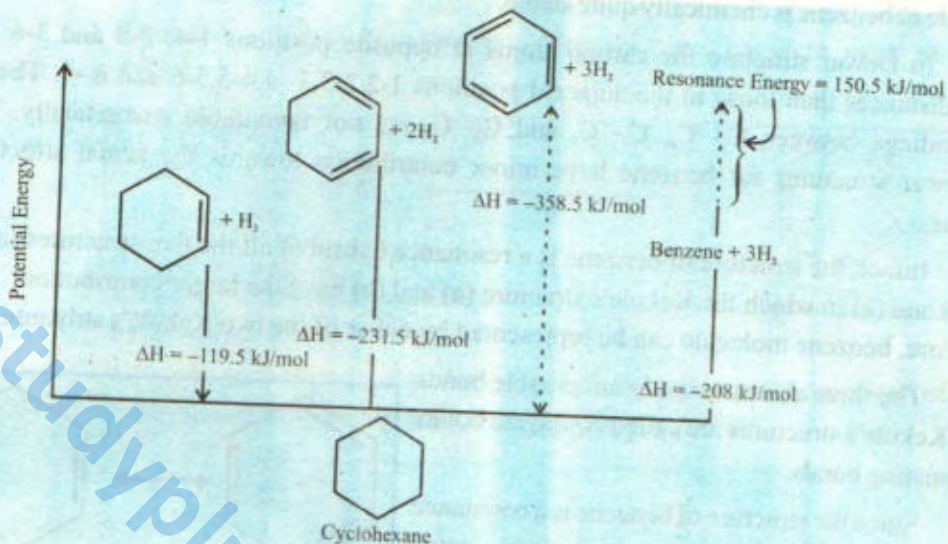

Fig.9.1 Relative stabilities of Cyclohexene, 1,3-Cyclohexadiene, 1,3,5-Cyclohexatriene (hypothetical) and benzene

Indeed, benzene is more stable than the hypothetical 1,3,5-cyclohexatriene by 150.5 kJ/mol. This difference between amount of heat actually released and that calculated on the basis of the Kekule's structure is now called the 'Resonance energy' of the compound. It means benzene shows the phenomenon of resonance which makes it more stable than others. In benzene electrons are delocalized making it a very stable molecule.

### 9.3.7 The Resonance Method Resonance

"The possibility of different pairing schemes of valence electrons of atoms is called resonance" and the different structures thus arranged are called "Resonance structures".

The resonance is represented by a double headed arrow ( $\leftrightarrow$ ) e.g. the following different pairing schemes of the fourth valence (the p-electrons) of carbon atoms are possible in benzene.

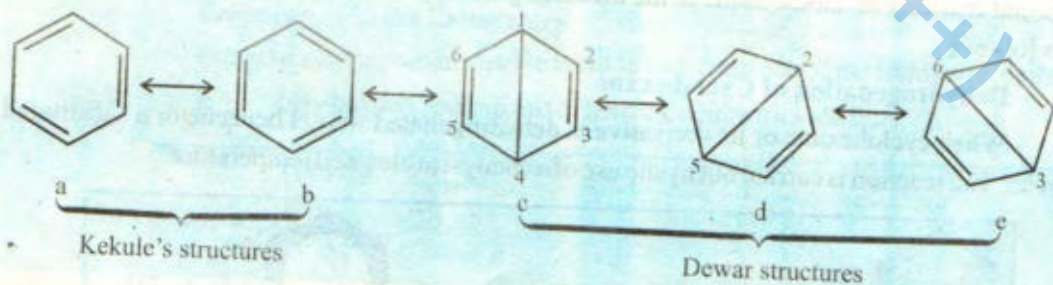

(a), (b) were proposed by Kekule and c, d, e, were proposed by Dewar. The stability of a molecule increases with increase in the number of its resonance structures. Thus

molecule of benzene is chemically quite stable.

In Dewar structure the carbon atoms at opposite positions 1-4, 2-5 and 3-6 are at larger distances than those in the adjacent positions 1-2, 2-3, 3-4, 4-5, 5-6 and 6-1. Therefore the bondings between  $C_1-C_4$ ,  $C_2-C_5$  and  $C_3-C_6$  are not favourable energetically. Hence the Dewar structures for benzene have minor contribution towards the actual structure of benzene.

In fact, the structure of benzene is a resonance hybrid of all the five structures (a), (b), (c), (d) and (e) in which the Kekule's structure (a) and (b) have the larger contribution. Therefore, benzene molecule can be represented by either of the two Kekule's structure.

The three alternate single and double bonds in the Kekule's structures are called conjugate bonds or resonating bonds.

Since the structure of benzene is a resonance hybrid, therefore all the C-C bond lengths are equal but different from those in alkanes, alkenes and alkynes.

In alkanes the C-C bond length is 1.54 Å.

In alkenes the C=C bond length is 1.34 Å.

In alkynes the C≡C bond length is 1.20 Å.

In benzene the C-C bond length is 1.397 Å.

The C-C bond length in benzene is intermediate between those in alkanes and alkenes. The resonating single and double bonds in benzene can better be represented as a complete circle inside the ring.

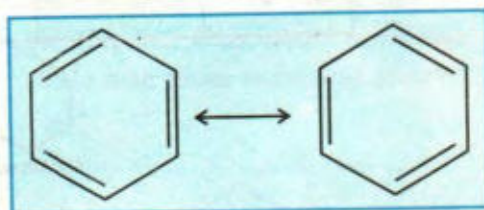

## 9.4 PREPARATION OF BENZENE

Benzene and other aromatic hydrocarbons are readily obtained in large quantities from coal and petroleum. Benzene and some other hydrocarbons can also be obtained from petroleum by special cracking methods. Some of the methods generally used for the preparation of benzene are as follows.

### 1. Dehydrogenation of Cyclohexane

When cyclohexane or its derivative is dehydrogenated we get benzene or a substituted benzene. The reaction is carried out by the use of a catalyst at elevated temperature.

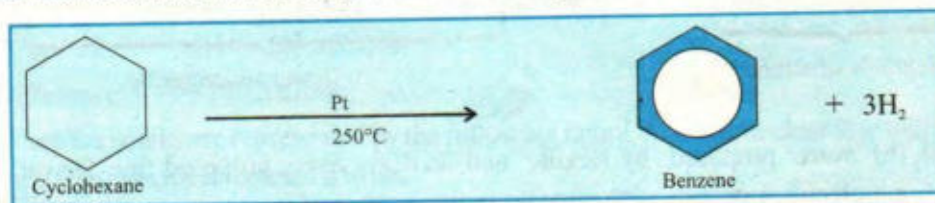

## 2. From Acetylene

Benzene is formed by passing acetylene under pressure over an organo-nickel catalyst at  $70^{\circ}\text{C}$ .

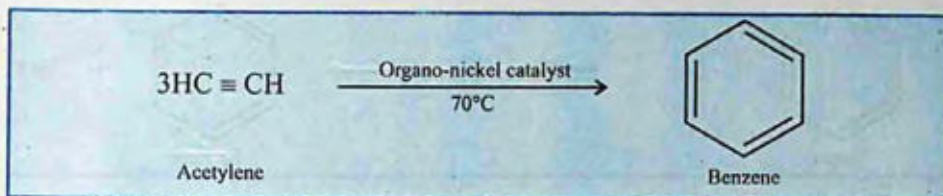

## 3. From Alkanes

Benzene and toluene are also prepared by passing the vapours of n-hexane or n-heptane over a mixture of catalysts  $\text{Cr}_2\text{O}_3 + \text{Al}_2\text{O}_3 + \text{SiO}_2$  at  $500^{\circ}\text{C}$ .

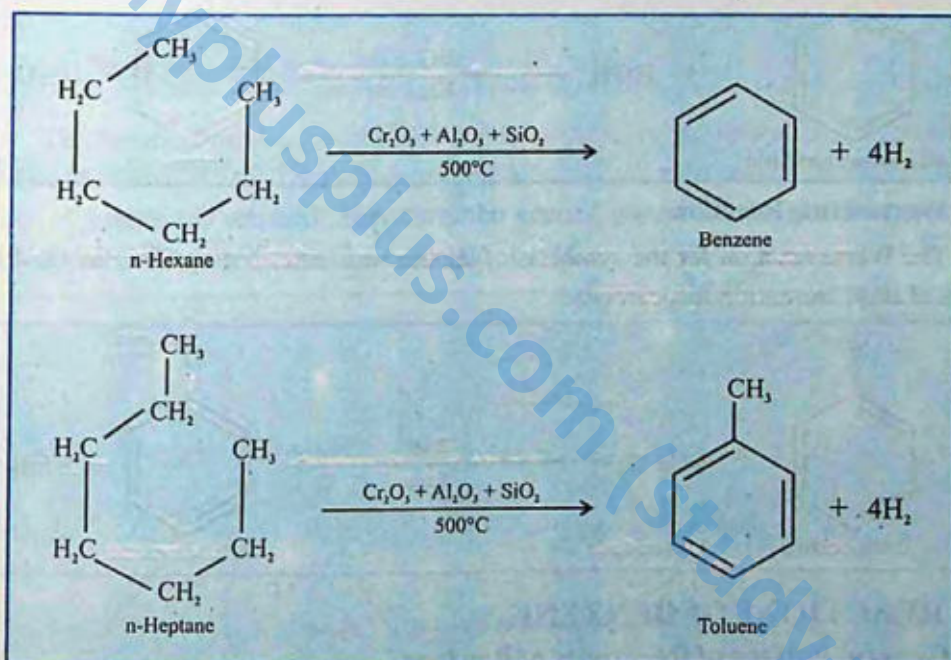

## 4. Preparation in the Laboratory

Benzene can be prepared in the laboratory by any one of the following methods.

- i. By heating sodium salt of benzoic acid with soda lime.

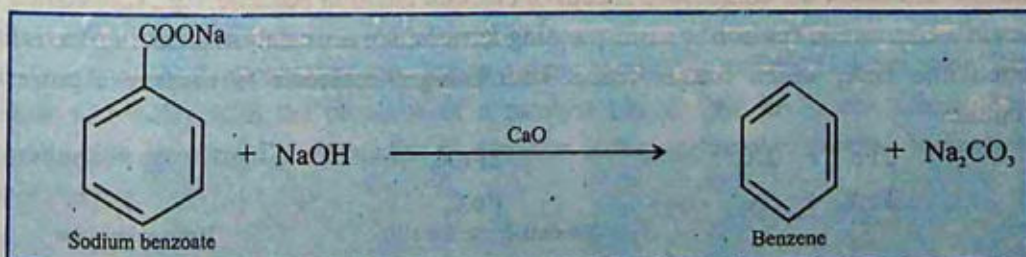

ii. By distilling phenol with zinc dust.

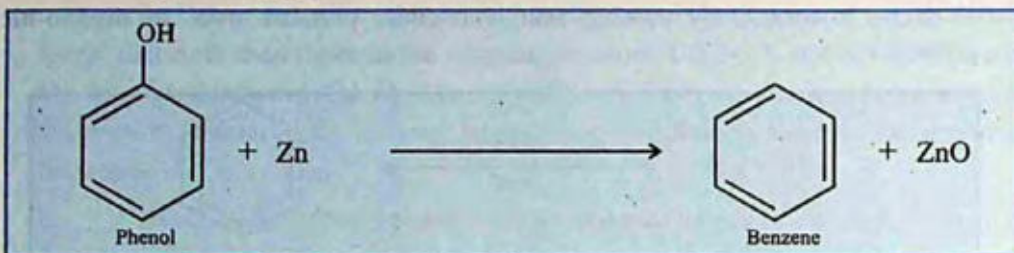

iii. By the hydrolysis of benzenesulphonic acid with superheated steam or by boiling with dil. HCl.

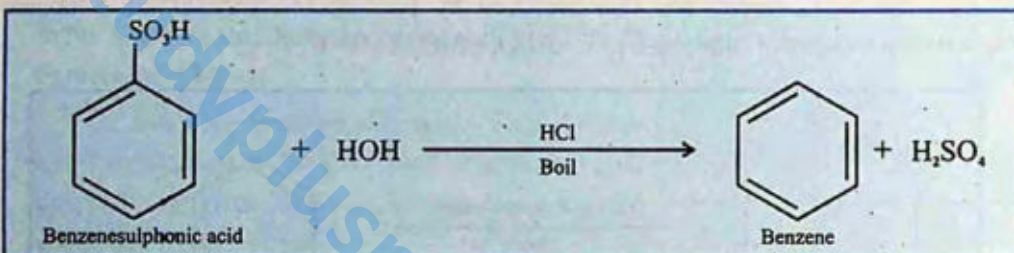

## 5. Wurtz-Fittig Reaction

The Wurtz reaction for the synthesis of alkanes was extended by Fittig in 1864 to the synthesis of alkyl aromatic hydrocarbons.

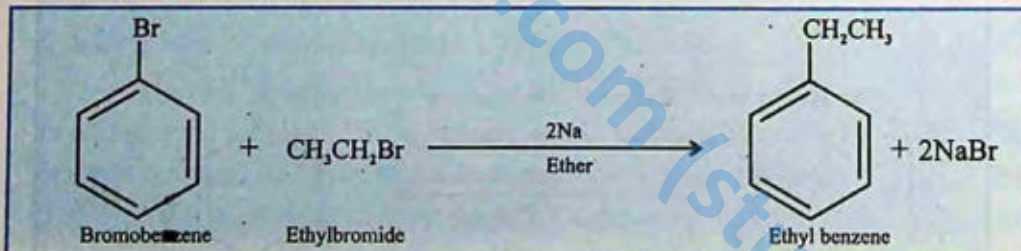

## 9.5 REACTIONS OF BENZENE

### 9.5.1 General Pattern of Reactivity of Benzene

The highly stable, delocalized electrons of benzene ring are not readily available for the nucleophilic attack like the electrons of alkenes. Therefore, the electrons of benzene ring do not assist in the attack of weak electrophiles. It means that more powerful electrophiles are required to penetrate and break the continuous sheath of electron cloud in benzene, e.g., substitution of halogen in benzene requires iron or corresponding ferric halide as a catalyst. In fact iron too is first converted into FeX<sub>3</sub>, which further reacts with halogen molecule to produce a powerful electrophile.

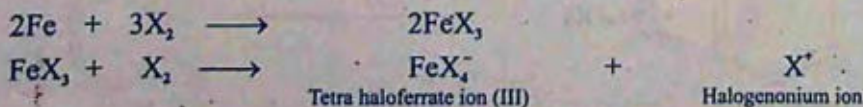

The halogenonium ion  $X^+$  thus produced attacks as a powerful electrophile on the electrons of benzene ring.

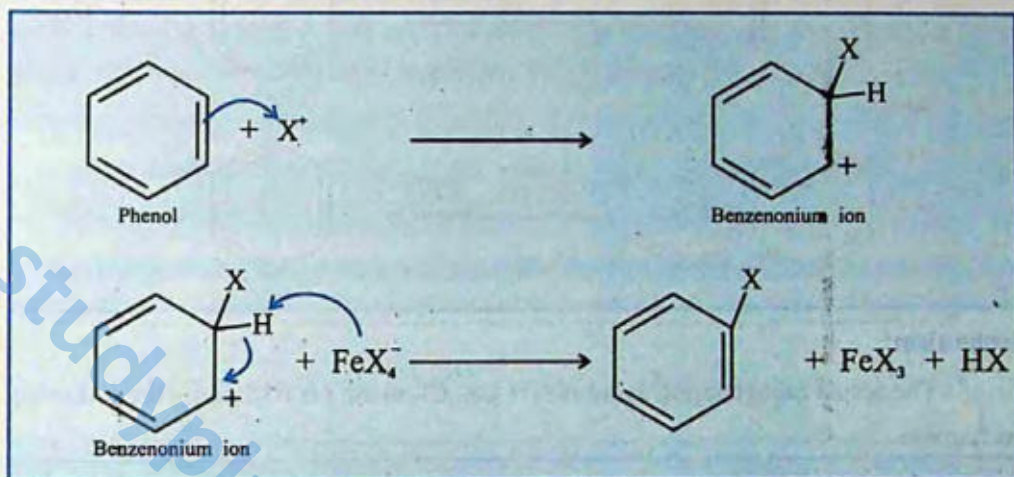

The addition product is not favourable because in its formation the characteristic stability of benzene is lost. The only possible product is the substitution product in which the stability of benzene is retained. Therefore, the general pattern of the chemical reactivity of benzene towards electrophiles can be shown as follows.

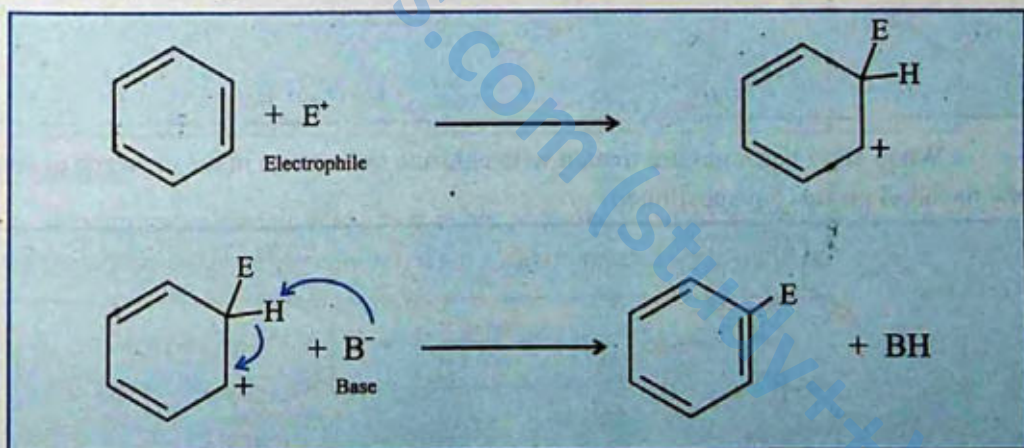

## 9.5.2 Electrophilic Substitution Reactions

### 1. Halogenation

The introduction of halogen group in benzene ring is called "Halogenation". Benzene reacts with halogen in the presence of a catalyst like  $FeBr_3$ ,  $AlCl_3$ , etc. Chlorination and bromination are normal reactions but fluorination is too vigorous to control. Iodination gives poor yield.

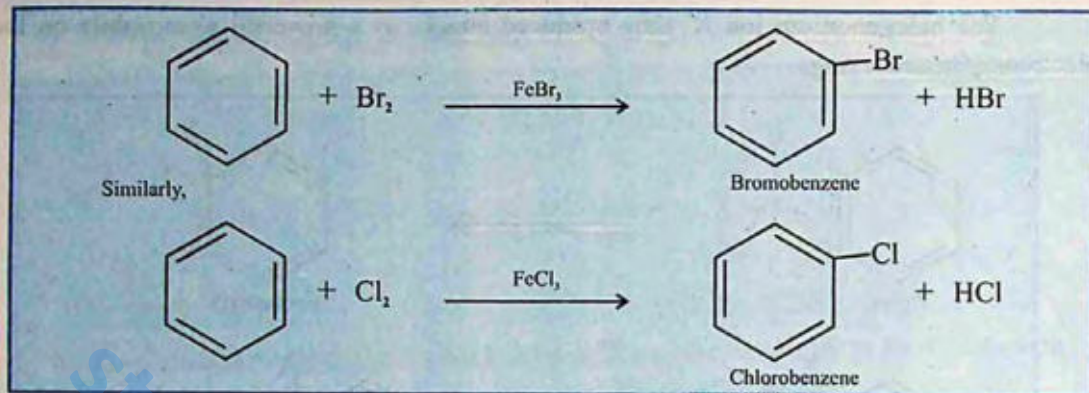
**Mechanism:**

The actual halogenating agent is  $X^+$  (i.e.,  $Cl^+$  or  $Br^+$ ) is formed by the following mechanism.

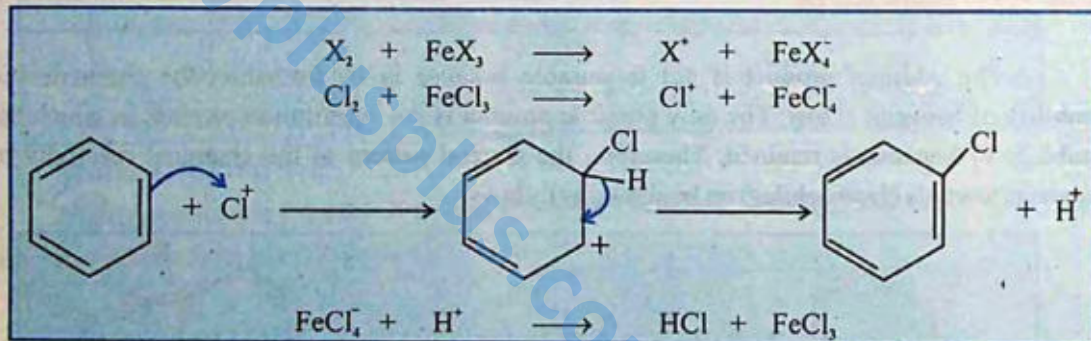

When alkyl benzenes are treated with chlorine or bromine in the presence of sunlight, only the alkyl groups are substituted.

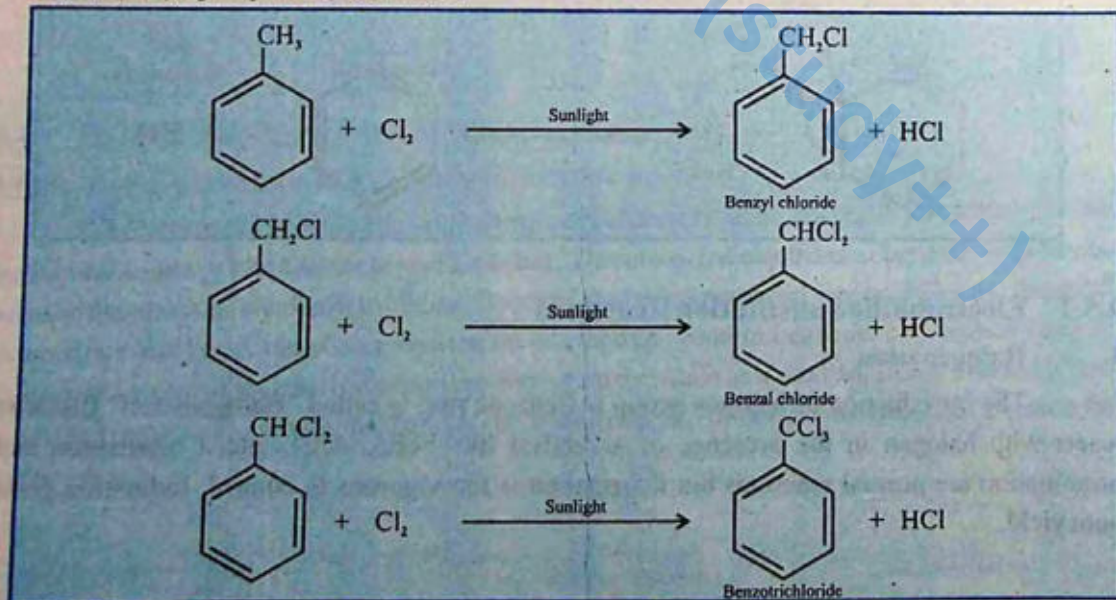

## 2. Nitration

The introduction of  $\text{NO}_2$  group in benzene ring is called "Nitration". The nitration of benzene takes place when it is heated with a 1:1 mixture of conc.  $\text{HNO}_3$  and conc.  $\text{H}_2\text{SO}_4$  at  $50-55^\circ\text{C}$ . Sulphuric acid reacts with nitric acid to generate nitronium ion, ( $\text{NO}_2^+$ ).

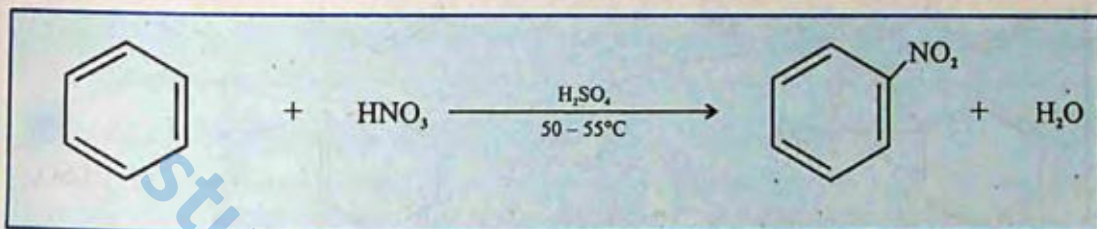

### Mechanism

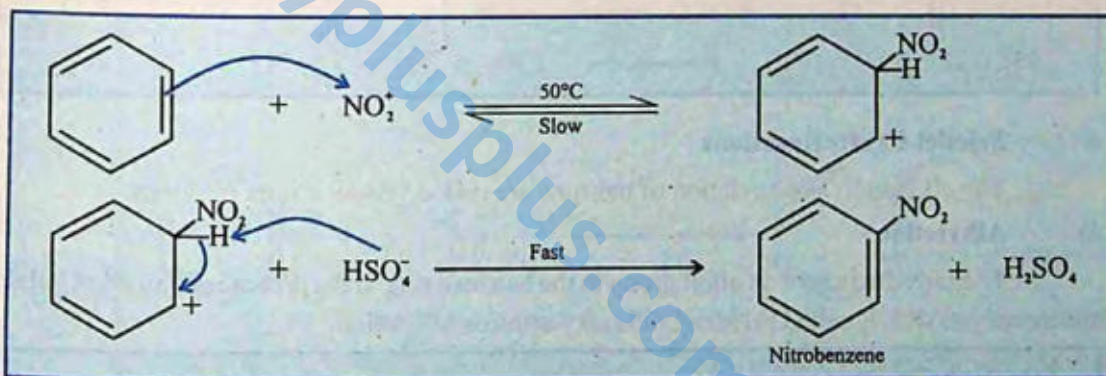
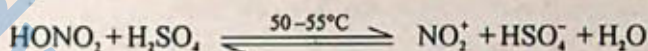

## 3. Sulphonation

The introduction of sulphonic acid group in benzene ring is called Sulphonation. When benzene is heated with fuming  $\text{H}_2\text{SO}_4$  or conc.  $\text{H}_2\text{SO}_4$  it yields benzene sulphonic acid.

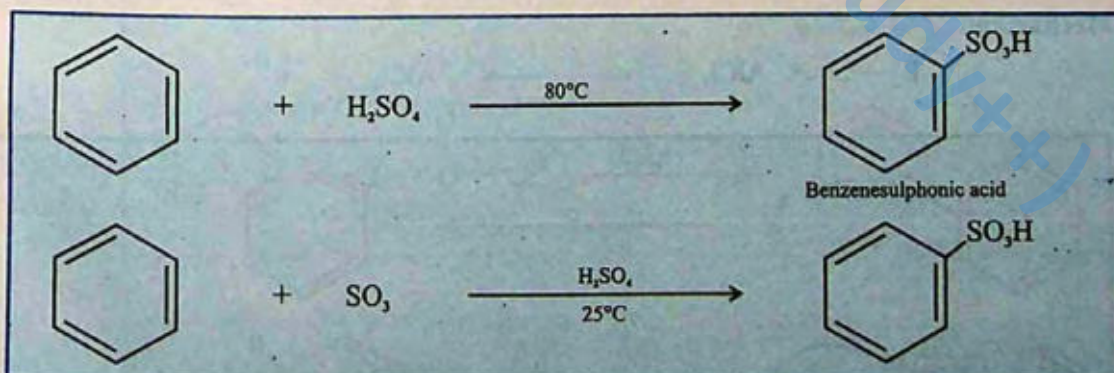

### Mechanism:

When sulphuric acid alone is used, the actual electrophile in this reaction is  $\text{SO}_3$ .

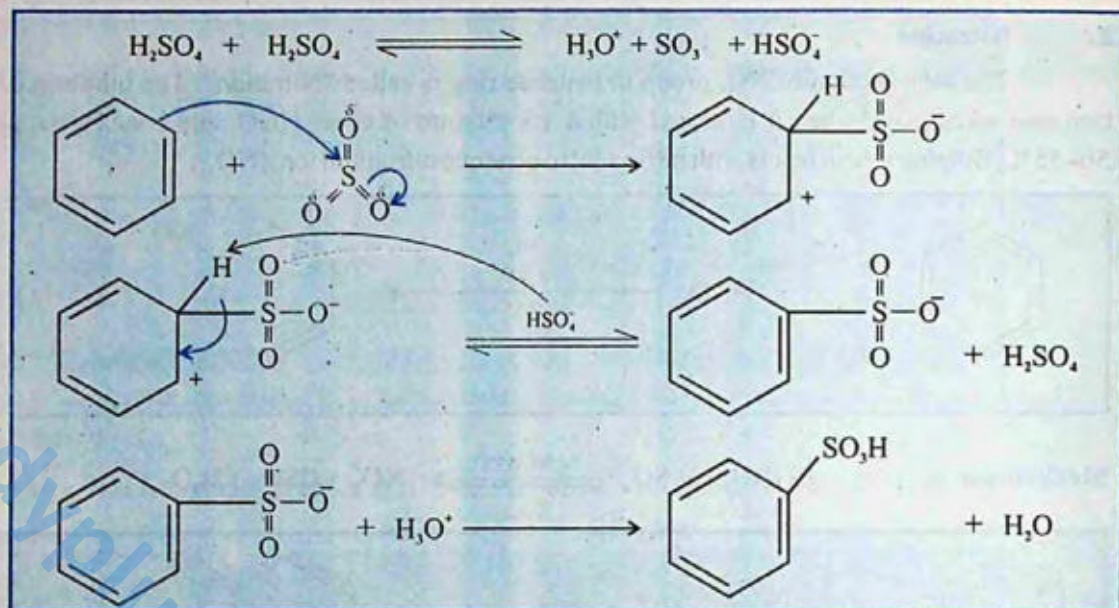

#### 4. Friedel-Crafts Reactions

The alkylation and acylation of benzene are called Friedel-Crafts reactions.

##### a) Alkylation

The introduction of an alkyl group in the benzene ring in the presence of an alkyl halide and a catalyst  $\text{AlCl}_3$  is called Friedel-Crafts alkylation or Alkylation.

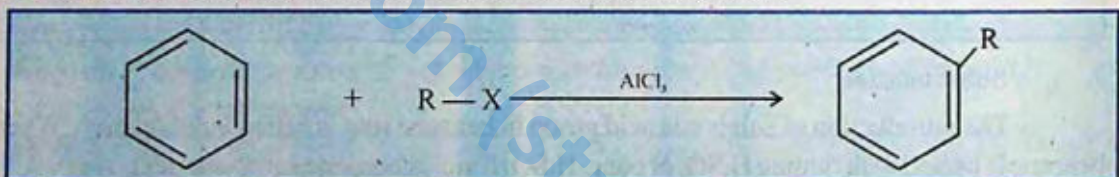

##### Mechanism:

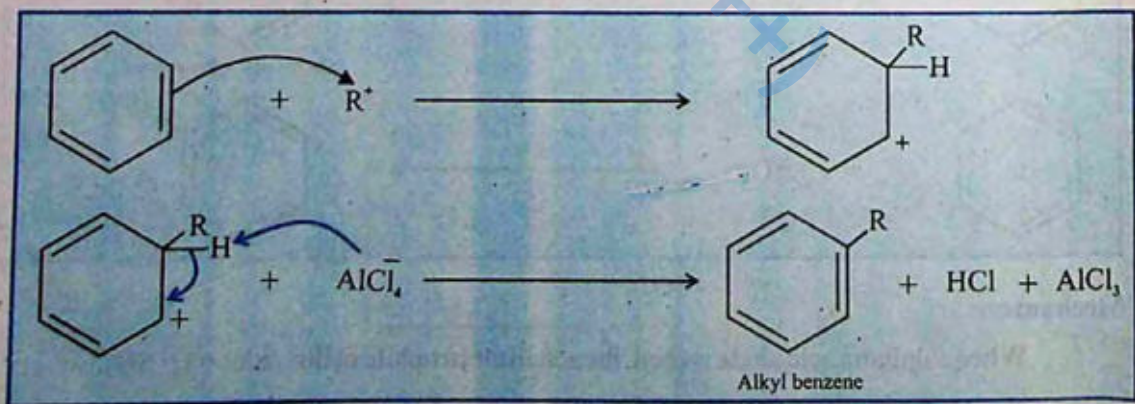

e.g.,

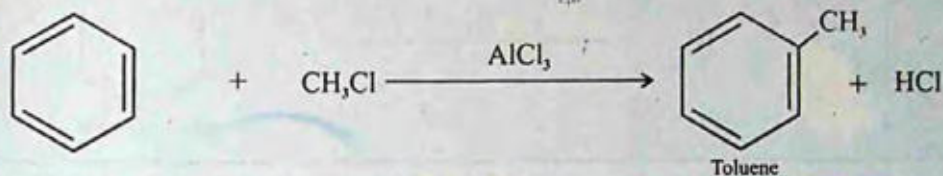

## b) Acylation

The introduction of an acyl group  $\text{R}-\overset{\text{O}}{\parallel}{\text{C}}$  in the benzene ring in the presence of an acyl halide and a catalyst  $\text{AlCl}_3$  is called Friedel-Crafts Acylation or Acylation.

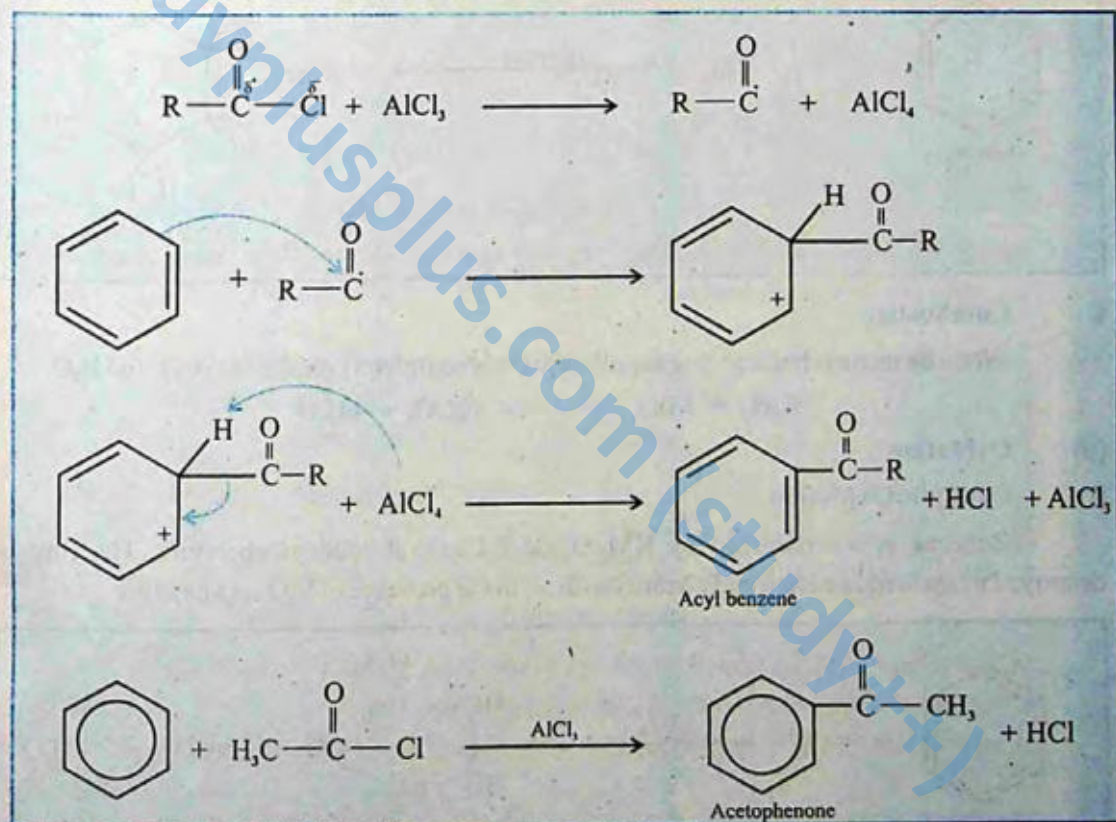

## 9.5.3 Reactions in which Benzene Ring is Involved

## 1. Addition Reactions

## (a) Reduction:

Benzene is reduced to cyclohexane on heating at high temperature with hydrogen in the presence of Pt in an acidic solvent (acetic acid) or Ni at  $200^\circ\text{C}$  as a catalyst.

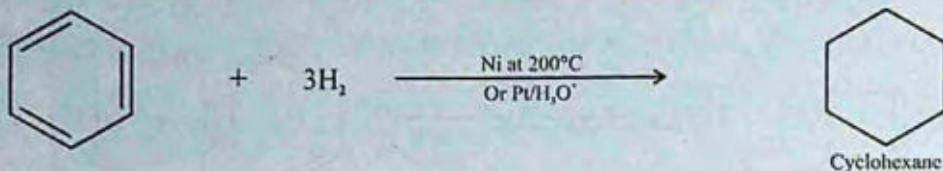
**(b) Halogenation**

Benzene reacts with chlorine and bromine in the presence of sunlight to give addition products, hexachlorocyclohexane or hexabromocyclohexane. Fluorination is too vigorous while iodination is slow.

**(c) Combustion**

When benzene is burnt in free supply of air, it is completely oxidized to  $\text{CO}_2$  and  $\text{H}_2\text{O}$ .

**(d) Oxidation****i) Catalytic Oxidation**

Benzene is not oxidized by  $\text{KMnO}_4$  or  $\text{K}_2\text{Cr}_2\text{O}_7$  at room temperature. The ring is destroyed when benzene is strongly heated with air in the presence of  $\text{V}_2\text{O}_5$  as a catalyst.

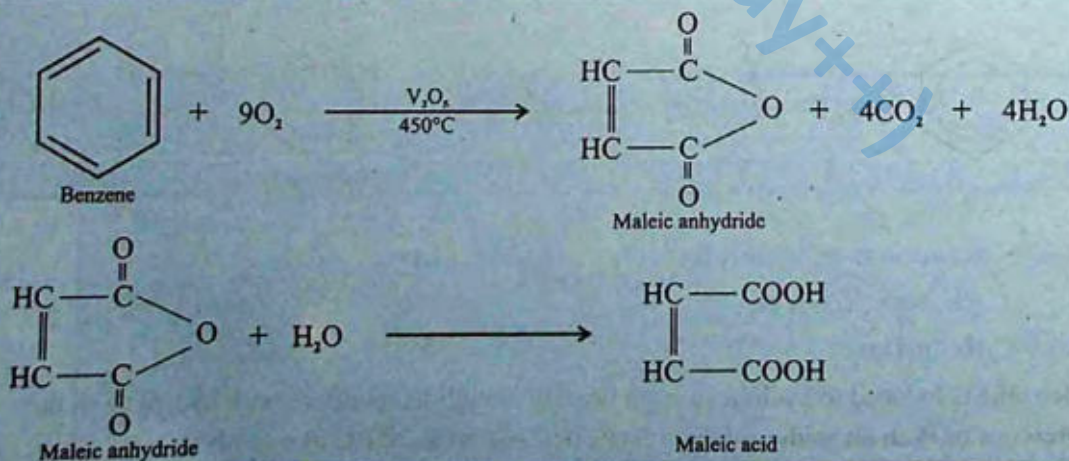

ii) **Ozonolysis**

Benzene reacts with ozone and gives glyoxal through benzene triozone.

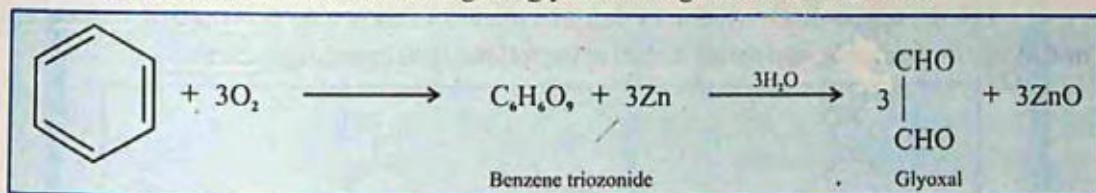
**Side Chain Oxidation**

Alkyl benzenes are readily oxidized by acidified  $\text{KMnO}_4$  or  $\text{K}_2\text{Cr}_2\text{O}_7$ . In these reactions, the alkyl groups are oxidized keeping the benzene ring intact.

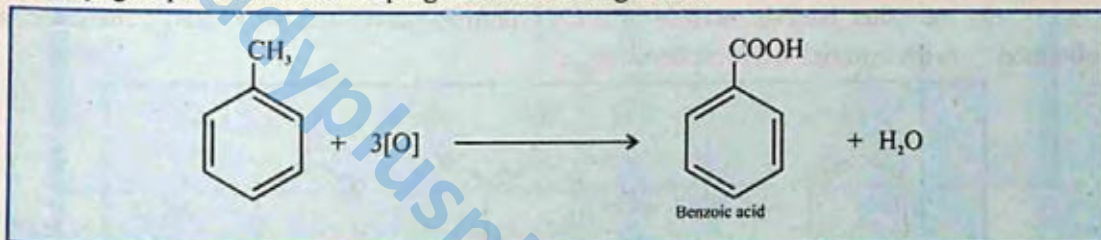

Whatever the length of an alkyl group may be it gives only one carboxyl group. Moreover the colour of  $\text{KMnO}_4$  is discharged. Therefore this reaction is used as a test for alkylbenzenes.

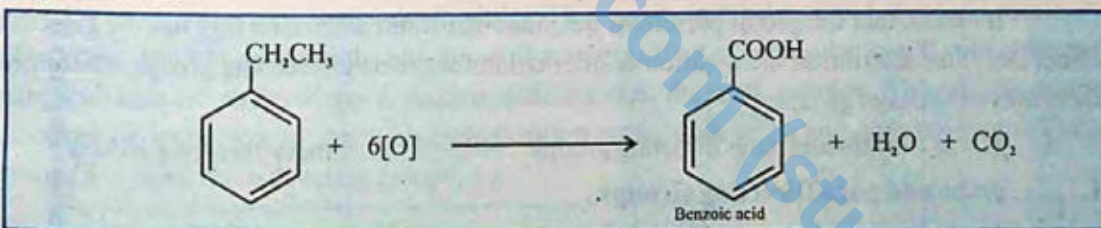
**9.5.4 Orientation in Electrophilic Substitution reactions**

When an electrophilic substitution reaction takes place on benzene ring, we get only one monosubstituted benzene because all the six positions in the ring are equivalent. However, the introduction of a second group into the ring may give three isomeric disubstituted products, ortho, meta and para.

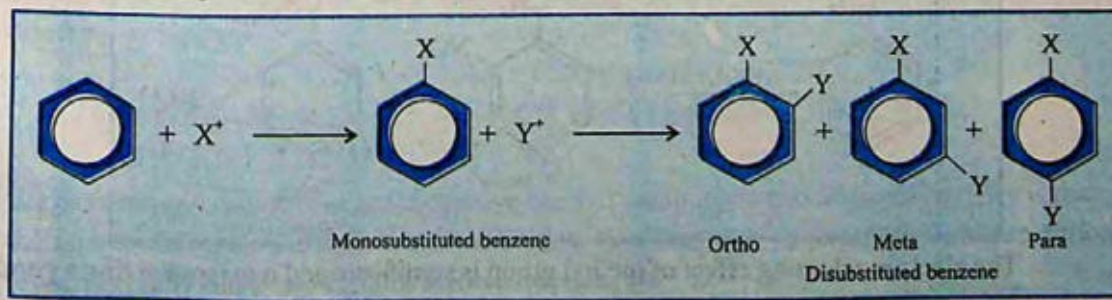

On chance basis 40% ortho, 40% meta and 20% para disubstituted products are expected.

But the actual disubstitution of benzene does not follow this principle of chance, e.g. m-Chloronitrobenzene is the main product of the following halogenation reaction.

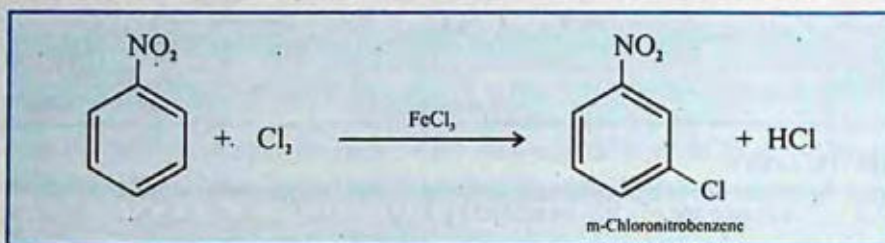

On the other hand a mixture of o-Chloronitrobenzene and p-Chloronitrobenzene is obtained from the nitration of chlorobenzene.

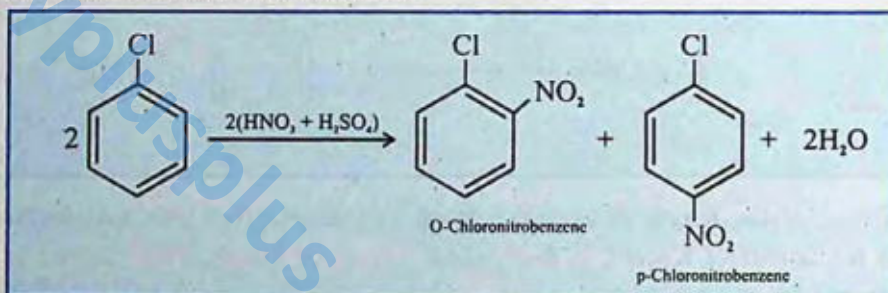

It means that the group present in the mono-substituted benzene ring has the directive effect and thus determines the position or orientation for the new incoming groups. Therefore, there are two types of groups:

1. ortho- and para- directing groups
2. meta- directing groups

### 1. ortho and para Directing Groups.

These groups release electrons to the benzene ring, thereby facilitating the availability of electrons to the electrophiles at ortho and para positions.

This results in the increased chemical reactivity of benzene ring towards electrophiles. The benzene ring can offer more than one positions (ortho and para) to the new incoming groups. These groups are called ortho and para directing groups, e.g.

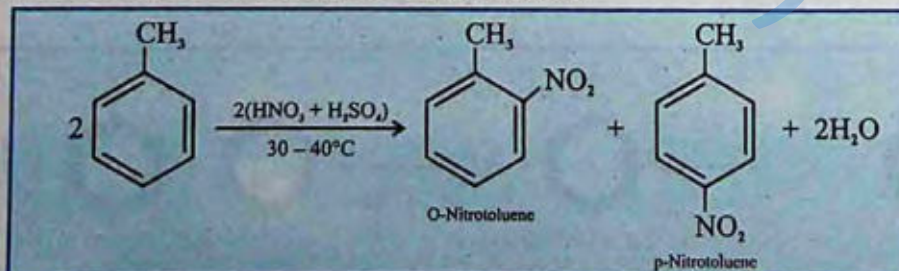

The electron releasing effect of methyl group is significant and it makes the ring a good

nucleophile. Due to this increased reactivity, more nitro groups can enter the ring.

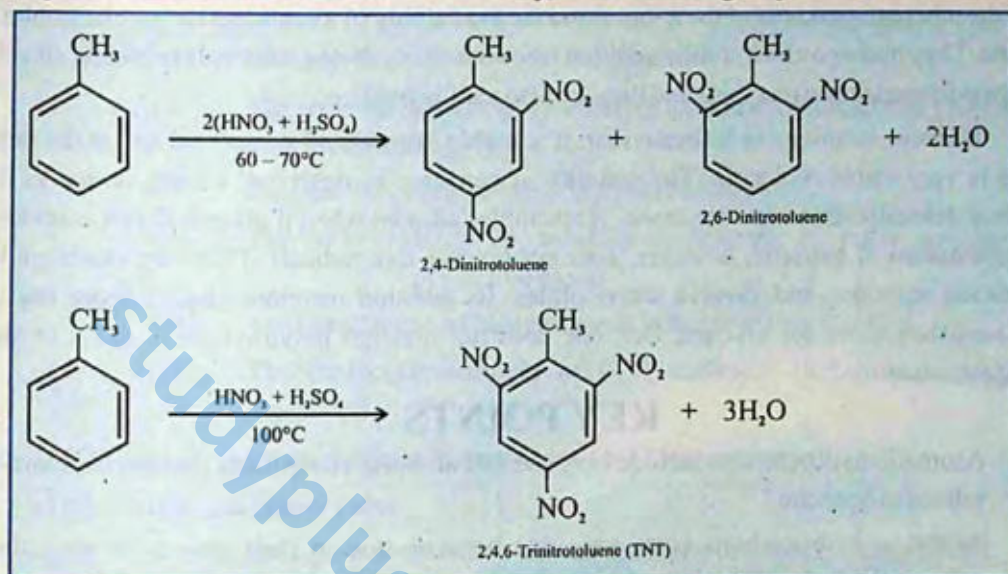

Other examples of ortho and para directing groups are:-

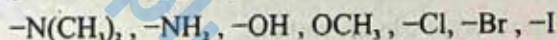

## 2. meta-Directing Groups

These groups withdraw the electrons of the benzene ring towards themselves, thereby reducing their availability to the electrophiles. This results in the decreased chemical reactivity of benzene. Moreover, due to the electron withdrawing effect of such substituents, the ortho and para positions are rendered more electron deficient than the meta position. Thus the incoming electrophile will prefer to attack on meta position rather than ortho and para positions. These groups are called meta-directing groups, e.g.

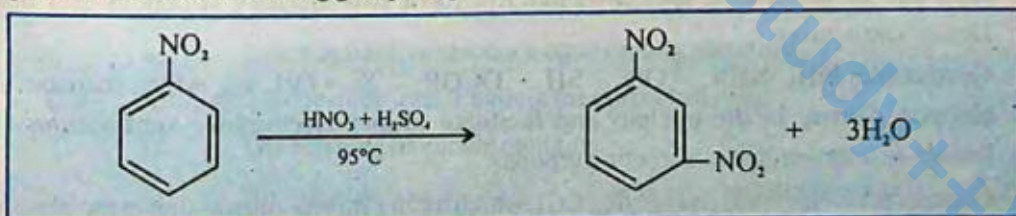

The substitution of third nitro group is not possible, other examples of meta directing groups are:

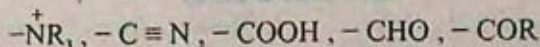

## 9.6 COMPARISON OF REACTIVITIES OF ALKANES, ALKENES AND BENZENE

We have studied that alkanes are unreactive class of compounds and their unreactivity is due to their non-polar nature and the inertness of  $\sigma$ -bond. However, they undergo substitution reactions relatively easily and these reactions involve free radicals.

Alkenes, on the other hand, are very reactive class of compounds and their reactivity is due to the inherent weakness of the  $\pi$ -bond and the availability of  $\pi$  electrons for the electrophilic reagents. They undergo electrophilic addition reactions easily. Being relatively unstable, alkenes undergo polymerization reactions and they are also readily oxidized.

Benzene is unique in its behaviour. It is highly unsaturated compound and at the same time it is very stable molecule. The stability of benzene, as described earlier, is due to the extensive delocalization of  $\pi$ -electrons. It resembles alkenes when it gives addition reactions. The substitution of benzene, however, does not involve free radicals. These are electrophilic substitution reactions and involve electrophiles. Its addition reactions require more drastic conditions than those for alkenes. Benzene does not undergo polymerization and it is also resistant to oxidation.

### KEY POINTS

1. Aromatic hydrocarbons include benzene and all those compounds that are structurally related to benzene.
2. Aromatic hydrocarbons containing one benzene ring in their molecules are called monocyclic aromatic hydrocarbons.
3. Aromatic hydrocarbons containing two or more benzene rings in their molecules are called polycyclic aromatic hydrocarbons.
4. Benzene was discovered by Michael Faraday in 1825.
5. The electrons in benzene are loosely held and the ring acts as a source of electrons. Hence benzene is readily attacked by electrophiles in the presence of a catalyst.
6. Since electrophilic substitutions reaction lead to resonance stabilized benzene derivatives so substitutions are the main reactions of benzene.
7. Resonance energy of benzene is 150.5 kJ/mol.
8. Structure of benzene is the resonance hybrid of two Kekule's structures and three Dewar's structures.
9. Groups like  $\text{NH}_2$ ,  $\text{NHR}$ ,  $-\text{OR}$ ,  $-\text{SH}$ ,  $-\text{OCOR}$ ,  $-\text{X}$ ,  $-\text{OH}$ , etc. which increase the electron density in the nucleus and facilitate further electrophilic substitutions are known as ortho- and para-directing groups.
10. Groups like  $\text{CN}$ ,  $-\text{CHO}$ ,  $\text{NH}_2$ ,  $\text{NR}_2$ ,  $\text{CCl}_3$  which hinder further substitution in the benzene nucleus are known as meta- directing groups.

### EXERCISE

Q1. Fill in the blanks.

- i) The term aromatic was derived from Greek word \_\_\_\_\_ meaning \_\_\_\_\_.
- ii) Aromatic hydrocarbons include benzene and all those compounds which are \_\_\_\_\_ related to benzene.

- iii) \_\_\_\_\_ is recognized as the simplest member of the class of Aromatic Hydrocarbons.
- iv) Benzene has \_\_\_\_\_ structure.
- v) The removal of hydrogen atom from aromatic hydrocarbons gives a radical. The radicals are called \_\_\_\_\_.
- vi) Benzene was discovered by Michael Faraday in \_\_\_\_\_.
- vii) The unhybridized  $2p$ , orbitals in benzene partially overlap to form a \_\_\_\_\_ of electron cloud.
- viii) The introduction of halogen group in benzene ring is called \_\_\_\_\_.
- ix) The molecular formula of  $C_6H_6$  indicates that it is highly \_\_\_\_\_ compound.
- x) On oxidation in the presence of  $V_2O_5$ , benzene gives \_\_\_\_\_.

**Q.2 Indicate True or False.**

- i) Benzene is more reactive than alkene and less reactive than alkane.
- ii) Benzene has a pentagonal structure.
- iii) The C-C bond length in benzene molecule is  $1.397 \text{ \AA}$ .
- iv) The state of hybridization of carbon in benzene molecule is  $sp^3$ .
- v) There are six sigma bonds in benzene molecule.
- vi) Halogenonium ion produced in electrophilic substitution reactions is a powerful electrophile.
- vii) In electrophilic substitution reactions, addition products are favourable.
- viii) Sulphonation is carried out when benzene is heated with conc.  $HNO_3$ .
- ix) In ozonolysis benzene directly gives glyoxal.
- x) Benzene has five resonance contributing structures.

**Q.3. Multiple choice questions. Encircle the correct answer.**

- i) The benzene molecule contains:
 

(a) three double bonds	(b) two double bonds
(c) one double bond	(d) delocalized $\pi$ -electron charge
- ii) Aromatic hydrocarbons are the derivatives of:
 

(a) normal series of paraffins	(b) alkene
(c) benzene	(d) cyclohexane
- iii) Which of the following acid can be used as a catalyst in Friedel-Crafts reactions?
 

(a) $AlCl_3$	(b) $HNO_3$	(c) $BeCl_2$	(d) $NaCl$
--------------	-------------	--------------	------------

- iv) Benzene cannot undergo:
- (a) substitution reactions (b) addition reactions  
(c) oxidation reactions (d) elimination reactions
- v) Amongst the following, the compound that can be most readily sulphonated is:
- (a) toluene (b) benzene (c) nitrobenzene (d) chlorobenzene
- vi) During nitration of benzene, the active nitrating agent is
- (a)  $\text{NO}_2$  (b)  $\text{NO}_2^+$  (c)  $\text{NO}_2^-$  (d)  $\text{HNO}_3$
- vii) Which compound is the most reactive one:
- (a) benzene (b) ethene (c) ethane (d) ethyne
- viii) The electrophile in aromatic sulphonation is:
- (a)  $\text{H}_2\text{SO}_4$  (b)  $\text{HSO}_4^-$  (c)  $\text{SO}_3$  (d)  $\text{SO}_3^+$
- ix) Aromatic compounds burn with sooty flame because:
- (a) they have high percentage of hydrogen.  
(b) they have a ring structure.  
(c) they have high percentage of carbon.  
(d) they resist reaction with air.
- x) The conversion of n-hexane into benzene by heating in the presence of Pt is called:
- (a) isomerization (b) aromatization  
(c) dealkylation (d) rearrangement

Q. 4. What are aromatic hydrocarbons? How are they classified?

Q. 5. What happens when:

- (a) benzene is heated with conc.  $\text{H}_2\text{SO}_4$  at  $250^\circ\text{C}$ .  
(b) chlorine is passed through benzene in sunlight.  
(c) a mixture of benzene vapours and air are passed over heated vanadium pentoxide.  
(d) benzene is burnt in free supply of air.

Q. 6. What is meant by the terms:

- i) Aromatic      ii) Oxidation      iii) Sulphonation  
iv) Nitration      v) Halogenation

Q. 7. (a) Draw structural formulas for the following compounds.

- i) m-Chlorobenzoic acid      vi) 2,4,6-Trinitrotoluene  
ii) p-Hydroxybenzoic acid      vii) m-Nitrophenol  
iii) o-Bromonitrobenzene      viii) p-Dibenzylbenzene  
iv) o-Ethyltoluene      ix) 2-Amino-5-bromo-3-nitrobenzenesulphonic acid  
v) p-Nitroaniline

- (b) Give names and the possible isomeric structures of the following.  
 i) Xylenes      ii) Trimethylbenzene      iii) Bromonitrotoluene

Q. 8. Write IUPAC names of the following molecules.

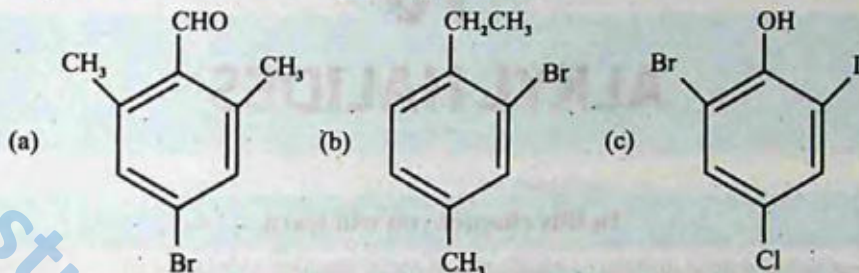

Q. 9. Give the general mechanism of the electrophilic aromatic substitution reactions.

Q. 10. (a) Describe the structure of benzene on the basis of following.

- i) Atomic orbital treatment      ii) Resonance method

(b) Prove that benzene has a cyclic structure.

Q. 11. Predict the major products of bromination of the following compounds.

- (a) Toluene      (b) Nitrobenzene      (c) Bromobenzene  
 (d) Benzoic acid      (e) Benzaldehyde      (f) Phenol

Q. 12. How will you prepare the following compounds from benzene in two steps.

- (a) m-chloronitrobenzene      (b) p-chloronitrobenzene

Q. 13. Complete the following reactions. Also mention the conditions needed to carry out these reactions.

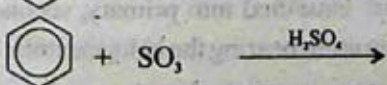
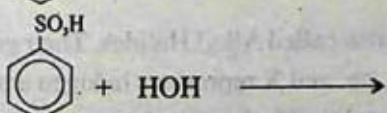
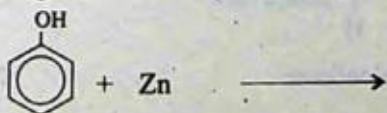
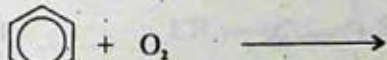
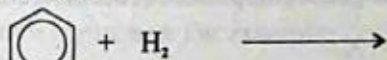

Q. 14. Detail out three reactions in which benzene behaves as if it is a saturated hydrocarbon and three reactions in which it behaves as if it is unsaturated.

Q. 15. What are Friedel-Crafts reactions. Give mechanism with example of the following reactions.

- i) Friedel-Crafts alkylation reactions      ii) Friedel-Crafts acylation reactions.

## CHAPTER

## 10

## ALKYL HALIDES

## In this chapter you will learn

1. How to name an alkyl halide and to classify it into primary, secondary and tertiary alkyl halides.
2. Simple ways of generating alkyl halides.
3. The reason why C-X bond in chemistry is one of the most reactive type.
4. The general mechanistic details of nucleophilic substitution and elimination reactions.
5. The preparation of Grignard's reagent, the reactivity of C-Mg bond and its synthetic applications in organic chemistry.

## 10.1 INTRODUCTION

Halogen derivatives of alkanes are called haloalkanes. They may be mono, di, tri or poly haloalkanes depending upon the number of halogen atoms present in the molecule.

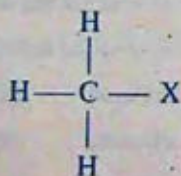

Monohaloalkane

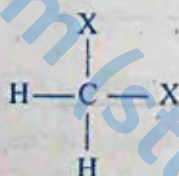

Dihaloalkane

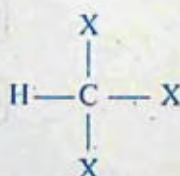

Trihaloalkane

Among these, monohaloalkanes are also called Alkyl Halides. Their general formula is R-X, where R may be methyl, ethyl, propyl, etc. and X represents halogen atoms (F, Cl, Br, I). Mono haloalkanes or alkyl halides are further classified into primary, secondary and tertiary alkyl halides depending upon the type of carbon atom bearing the halogen atom.

In a primary alkyl halide halogen atom is attached with a carbon which is further attached to one or no carbon atom e.g.,



Chloromethane

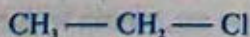

Chloroethane



1-Chloropropane

Secondary alkyl halides are those in which halogen atom is attached with a carbon atom which is further attached to two other carbon atoms directly, e.g., secondary carbon atom.

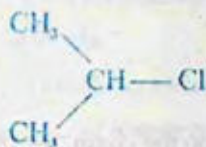

2-Chloropropane

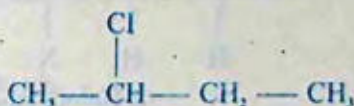

2-Chlorobutane

In tertiary alkyl halides halogen atom is attached to a carbon which is further attached to three carbon atoms directly.

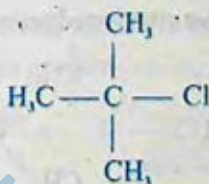

2-Chloro-2-methylpropane

## 10.2 NOMENCLATURE OF ALKYL HALIDES

### COMMON NAMES

Alkyl halides (monohaloalkanes) are named according to the nature of the alkyl group to which halogen atom is attached. For example,



Methyl chloride

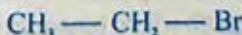

Ethyl bromide



n-Propyl bromide

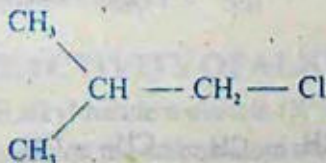

Isobutyl chloride



n-Butyl chloride

### IUPAC Nomenclature

The systematic names given to alkyl halides follow the underlying rules.

1. Select the longest continuous carbon chain and consider the compound to have been derived from this structure.
2. Number the carbon atoms in the chain so that the carbon atom bearing the functional group (F, Cl, Br, I) gets the lowest possible number, e.g.,



### 10.3 METHODS OF PREPARATION OF ALKYL HALIDES

Alkyl halides can be prepared by the halogenation of alkanes and by the addition of halogen acids to alkenes. These methods have already been discussed in the previous chapters. The best method for the preparation of alkyl halides is from alcohols.

#### 1. From Alcohols

- (a) Reaction of alcohols with halogen acids.

Alcohols may be converted to the corresponding alkyl halides by the action of halogen acid in the presence of  $ZnCl_2$ , which acts as a catalyst.

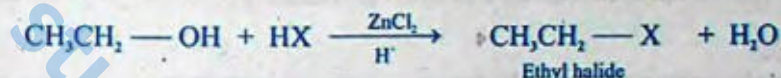

- (b) Alcohols also react with thionyl chloride in pyridine as a solvent to give alkyl chlorides. This method is especially useful since the by-products ( $HCl$ ,  $SO_2$ ) are gases, which escape leaving behind the pure product.

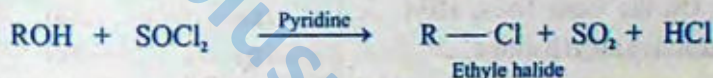

- (c) Phosphorus trihalides or phosphorus pentahalides react with alcohols to replace  $-OH$  group by a halo group.



2. An excellent method for the preparation of simple alkyl iodide is the treatment of alkyl chloride or alkyl bromide with sodium iodide. This method is particularly useful because alkyl iodides cannot be prepared by the direct iodination of alkanes.



### 10.4 REACTIVITY OF ALKYL HALIDES

An alkyl halide molecule ( $R-X$ ) consists of two parts, an alkyl group with a partial positive charge on the carbon atom attached to halogen atom and the halide atom with a partial negative charge.

There are two main factors which govern the reactivity of  $R-X$  bond.

These are:

- i)  $C-X$  Bond energy
- ii)  $C-X$  Bond polarity

## Bond Energy

The following table shows the bond energies of C — X bonds in alkyl halides. The strength of the bonds show that iodo compound (with the weakest bonds) would be the most reactive one while fluoro compound will be the least reactive i.e., the order of reactivity of alkyl halides should be



## Bond Polarity

Electronegativities of halogen, carbon and hydrogen atoms present in alkyl halides are shown in the table.

The greatest electronegativity difference exists between carbon and fluorine atoms in alkyl fluorides. If an electrophile is the attacking reagent then this difference suggests that alkyl fluorides would be the most reactive one. On the same lines, alkyl iodides should be the least reactive alkyl halides.

In the light of the above discussion it is clear that the two factors mentioned above predict different types of behaviour about the reactivity of alkyl halides. Experiments have shown that the strength of carbon halogen bond is the main factor which decides the reactivity of alkyl halides.

So the overall order of reactivity of alkyl halides for a particular alkyl group is:

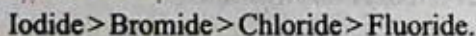

In fact the C—F bond is so strong that alkyl fluorides do not react under ordinary conditions.

Bond	Bond Energy (kJ/mol)
C—F	467
C—H	413
C—Cl	346
C—Br	290
C—I	228

Atom	Electronegativity
F	4.0
Cl	3.0
Br	2.8
I	2.5
H	2.1
C	2.5

## 10.5 REACTIONS OF ALKYL HALIDES

The reactions of alkyl halides fall into two categories.

1. Those reactions in which the halogen is replaced by some other atom or a group (nucleophilic substitution, or  $S_N$  reactions).
2. Those which involve the removal of HX from the alkyl halide (elimination, or E reactions).

### 10.5.1 Nucleophilic Substitution Reactions

Before discussing specifically the nucleophilic substitution reactions ( $S_N$ ) of alkyl halides, let us look at the nucleophilic reaction in general. The overall process describing an  $S_N$  reaction is shown as follows:



In this equation the incoming group Nu is a nucleophile. Nucleophile means nucleus loving. It has an unshared electron pair available for bonding and in most cases it is basic in character. It may be negatively charged or neutral.

### Examples of Nucleophiles

OH <sup>-</sup>	Hydroxide ion	Cl <sup>-</sup>	Chloride ion
C <sub>2</sub> H <sub>5</sub> O <sup>-</sup>	Ethoxide ion	Br <sup>-</sup>	Bromide ion
HS <sup>-</sup>	Hydrogen sulphide ion	$\bar{\text{N}}\text{H}_3$	Ammonia
SCN <sup>-</sup>	Thiocyanate ion	CN <sup>-</sup>	Cyanide ion
H <sub>2</sub> O:	Water	I <sup>-</sup>	Iodide ion
NH <sub>2</sub> <sup>-</sup>	Amino group		

### Electrophile

It is a specie which attracts electrons (electron loving). The carbon atom of an alkyl group attached with the halogen atom and bearing a partial positive charge is called an electrophile or electrophilic center. An electrophile may be neutral or positively charged.

### Leaving Group

L is also a nucleophile. It is called leaving group because it departs with an unshared pair of electrons. If we wish a S<sub>N</sub> reaction to proceed in the forward direction the incoming nucleophile must be stronger than the departing one. Cl<sup>-</sup>, Br<sup>-</sup>, I<sup>-</sup>, HSO<sub>4</sub><sup>-</sup> are good leaving groups. Poor leaving-groups are OH<sup>-</sup>,  $\bar{\text{O}}\text{R}$  and NH<sub>2</sub><sup>-</sup>. Iodide ion is a good nucleophile as well as a good leaving group.

### Substrate Molecule

The alkyl halide molecule on which a nucleophile attacks is called a substrate molecule.

## 10.5.2 Mechanism of Nucleophilic Substitution Reactions

Alkyl halides may undergo nucleophilic substitution reactions in two different ways:

1. Nucleophilic Substitution Bimolecular (S<sub>N</sub>2)
2. Nucleophilic Substitution Unimolecular (S<sub>N</sub>1)

Nucleophilic substitution reactions on alkyl halides involve two main processes, the breakage of C—X bond and the formation of C—Nu bond. The mechanism of the nucleophilic substitution reactions depends upon the timing of these two processes. If the two processes occur

simultaneously the mechanism is called  $S_N2$ . If the bond breaks first followed by the formation of a new bond, the mechanism is called  $S_N1$ .

### Nucleophilic Substitution Bimolecular ( $S_N2$ )

This is a single step mechanism. As soon as the nucleophile starts attacking the electrophilic carbon of the substrate, the bond with which the leaving group is attached, starts breaking. In other words the extent of bond formation is equal to the extent of bond breakage.

Another important feature of this mechanism is the direction of the attack of the attacking nucleophile. It attacks from the side which is opposite to the leaving group.

In order to give to the nucleophile enough room to attack, the substrate carbon atom changes its state of hybridization from tetrahedral  $sp^3$  to planar  $sp^2$ . The attack of the nucleophile, the change in the state of hybridization and the departure of the leaving group, everything occurs at the same time.

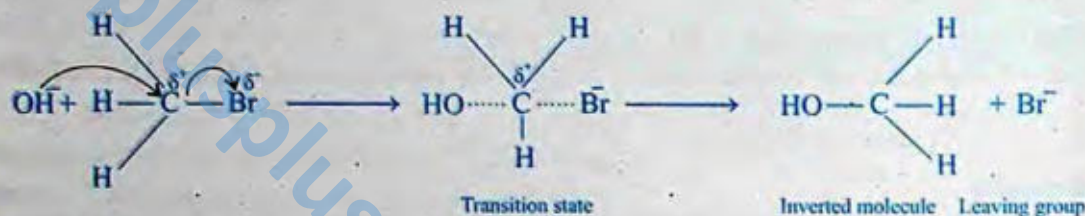

During the reaction, the configuration of the alkyl halide molecule gets inverted. This is called inversion of configuration.

Molecularity of a reaction is defined as the number of molecules taking part in the rate determining step. Since in this mechanism, the reaction takes place in only one step which is also a rate determining step and two molecules are participating in this step, so it is called a bimolecular reaction.

Kinetic studies of the reactions involving  $S_N2$  mechanism have shown that the rates of such reactions depend upon the concentrations of alkyl halide as well as the attacking nucleophile. Mathematically, the rate can be expressed as:

$$\text{Rate} = k [\text{Alkyl halide}]^1 [\text{Nucleophile}]^1$$

Since the exponents of the concentration terms in the above expression are unity, so the order of a typical  $S_N2$  reaction will be  $1 + 1 = 2$ .

Among the alkyl halides, the primary alkyl halides always follow  $S_N2$  mechanism whenever they are attacked by nucleophiles.

### Nucleophilic Substitution Unimolecular ( $S_N1$ )

This type of mechanism involves two steps. The first step is the reversible ionization of the alkyl halide in the presence of an aqueous acetone or an aqueous ethyl alcohol. This step

provides a carbocation as an intermediate. In the second step this carbocation is attacked by the nucleophile to give the product.

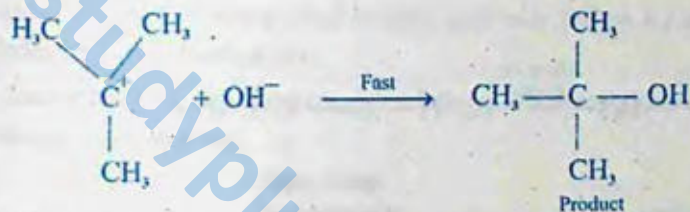
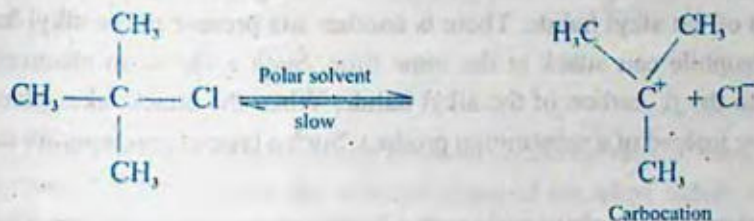

Since the first step involves the breakage of a covalent bond so it is a slow step as compared to the second step which involves the energetically favourable combination of ions. The first step is, therefore, called the rate-determining step. The mechanism is called unimolecular because only one molecule takes part in the rate determining step.

In  $S_N1$  mechanism, the nucleophile attacks when the leaving group had already gone, so the question of the direction of the attack does not arise. Moreover, the intermediate carbocation is a planar specie allowing the nucleophile to attack on it from both the directions with equal ease. We, therefore, observe 50% inversion of configuration and 50% retention of configuration.

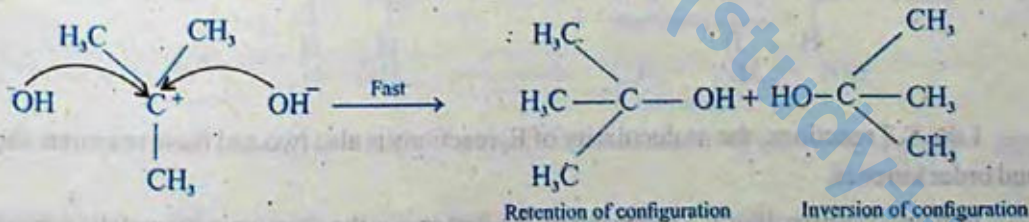

Reactions involving  $S_N1$  mechanism show first order kinetics and the rates of such reactions depend only upon the concentration of the alkyl halide. The rate equation of such reactions can be written as follows.

$$\text{Rate} = k [\text{Alkyl halide}]$$

Tertiary alkyl halides when attacked by a nucleophile always follow  $S_N1$  mechanism. Secondary alkyl halides, on the other hand, follow both  $S_N1$  and  $S_N2$  mechanisms.

### 10.5.3 $\beta$ -Elimination Reactions

During nucleophilic substitution reactions, the attacking nucleophile attacks the electrophilic carbon atom of the alkyl halide. There is another site present in the alkyl halide molecule where the nucleophile can attack at the same time. Such a site is an electrophilic hydrogen atom attached to the  $\beta$ -carbon of the alkyl halide. When the attack takes place on hydrogen, we get an alkene instead of a substitution product. Such a type of reactions are called elimination reactions.

These reactions take place simultaneously with substitution reactions and often compete with them.

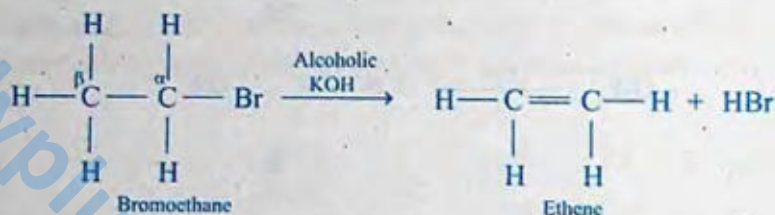

Like nucleophilic substitutions, the elimination reactions can also follow  $E_2$  or  $E_1$  mechanism. In  $E_2$  mechanism, the nucleophile attacks and the leaving group leaves at the same time with a formation of carbon carbon double bond.

The single step  $E_2$  elimination

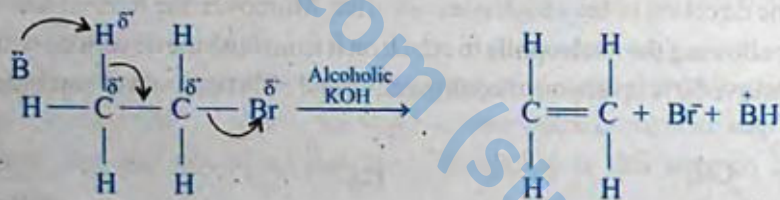

Like  $S_N2$  reactions, the molecularity of  $E_2$  reactions is also two and these reactions show second order kinetics.

In  $E_1$  mechanism, like  $S_N1$  mechanism, the first step is the slow ionization of the substrate to give a carbocation. In the second step, the nucleophile attacks on hydrogen to give an alkene as a product.

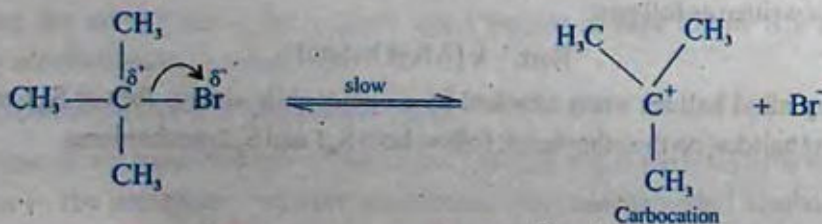

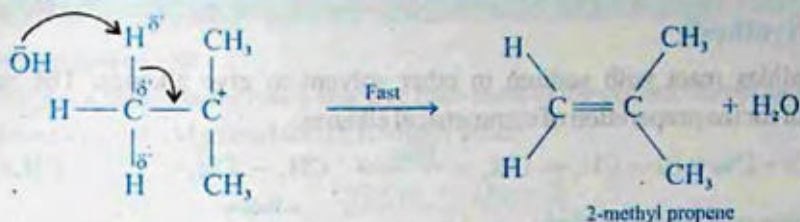

E2 mechanism is a bimolecular mechanism and the rates of those reactions which follow this mechanism depend upon the concentrations of the alkyl halide as well as the attacking nucleophile or a base. E1 mechanism, on the other hand, is a unimolecular mechanism and the rates of those reactions which follow this mechanism depend only upon the concentration of the alkyl halide molecule. Primary alkyl halides generally follow E2 mechanism whereas tertiary alkyl halides follow E1 mechanism.

Examples of  $S_N$  reactions are given below. These reactions show the usefulness of alkyl halides as synthetic reagents.

Substrate	Attacking Nucleophile	Product
$\text{CH}_3 - \overset{\delta^+}{\text{C}}\text{H}_2 - \text{Br}^{\delta^-}$	+ $\text{OH}^-$	$\text{C}_2\text{H}_5\text{OH} + \text{Br}^-$ Ethyl alcohol
$\text{CH}_3 - \overset{\delta^+}{\text{C}}\text{H}_2 - \text{Br}^{\delta^-}$	+ $\text{I}^-$	$\text{C}_2\text{H}_5\text{I} + \text{Br}^-$ Ethyl iodide
$\text{CH}_3 - \overset{\delta^+}{\text{C}}\text{H}_2 - \text{Br}^{\delta^-}$	+ $\text{CN}^-$	$\text{C}_2\text{H}_5\text{CN} + \text{Br}^-$ Propane nitrile
$\text{CH}_3 - \overset{\delta^+}{\text{C}}\text{H}_2 - \text{Br}^{\delta^-}$	+ $\text{NO}_2^-$	$\text{C}_2\text{H}_5\text{NO}_2 + \text{Br}^-$ Nitroethane
$\text{CH}_3 - \overset{\delta^+}{\text{C}}\text{H}_2 - \text{Br}^{\delta^-}$	+ $\text{CH}_3\text{O}^-$	$\text{CH}_3 - \text{CH}_2 - \text{O} - \text{CH}_3 + \text{Br}^-$ Ethyl methyl ether
$\text{CH}_3 - \overset{\delta^+}{\text{C}}\text{H}_2 - \text{Br}^{\delta^-}$	+ $\text{NH}_3$	$\text{C}_2\text{H}_5 - \text{NH}_2 + \text{HBr}$ Ethylamine
$\text{CH}_3 - \overset{\delta^+}{\text{C}}\text{H}_2 - \text{Br}^{\delta^-}$	+ $\text{CH}_3 - \text{CH}_2 - \text{NH}_2$	$(\text{CH}_3 - \text{CH}_2)_2\text{NH} + \text{HBr}$ Diethylamine
$\text{CH}_3 - \overset{\delta^+}{\text{C}}\text{H}_2 - \text{Br}^{\delta^-}$	+ $(\text{CH}_3 - \text{CH}_2)_2\text{NH}$	$(\text{CH}_3 - \text{CH}_2)_3\text{N} + \text{HBr}$ Triethylamine
$\text{CH}_3 - \overset{\delta^+}{\text{C}}\text{H}_2 - \text{Br}^{\delta^-}$	+ $(\text{CH}_3 - \text{CH}_2)_3\text{N}$	$(\text{CH}_3 - \text{CH}_2)_4\text{N}^+ + \text{Br}^-$ Quarternary ethylammonium ion
$\text{CH}_3 - \overset{\delta^+}{\text{C}}\text{H}_2 - \text{Br}^{\delta^-}$	+ $\text{SH}^-$	$\text{C}_2\text{H}_5\text{SH} + \text{Br}^-$ Ethyl thioalcohol
$\text{CH}_3 - \overset{\delta^+}{\text{C}}\text{H}_2 - \text{Br}^{\delta^-}$	+ $\text{CH}_3\text{COO}^- \text{Na}^+$	$\text{CH}_3\text{COOC}_2\text{H}_5 + \text{NaBr}$ Ethyl acetate

Other reactions shown by alkyl halides are as follows:

### 1. Wurtz Synthesis

Alkyl halides react with sodium in ether solvent to give alkanes. The reaction is particularly useful for the preparation of symmetrical alkanes.

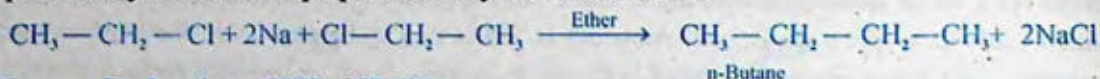

### 2. Reduction of Alkyl Halides

Alkyl halides can be reduced with zinc in the presence of an aqueous acid such as HCl or  $\text{CH}_3\text{COOH}$ .

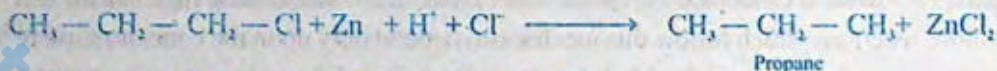

### 3. Reaction with Sodium Lead Alloy ( $\text{Na}_4\text{Pb}$ )

Methyl chloride and ethyl chloride react with sodium lead alloy giving tetramethyl lead and tetraethyl lead, respectively. These compounds are important anti-knock agents and are used in gasoline.



## 10.6 GRIGNARD REAGENT

Grignard reagents  $\text{RMgX}$  are derivatives of alkyl halides belonging to class of organometallic compounds. Grignard reagent was first prepared by Victor Grignard in 1900. These reagents are so important in organic synthesis that almost all the classes of organic compounds can be prepared from them. Due to their importance and applications Victor Grignard was awarded Nobel Prize in chemistry.

### Preparation:

Grignard reagents are prepared by the reaction of magnesium metal with alkyl halides in the presence of dry ether (alcohol free, moisture free).

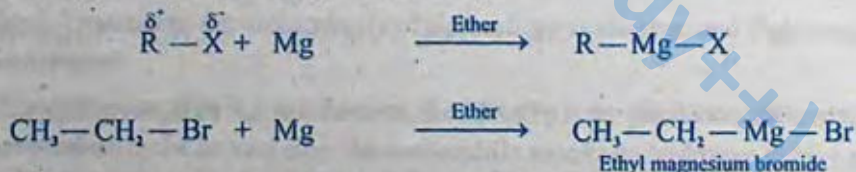

It is important that all the reactants must be absolutely dry and pure because Grignard reagents are so reactive that they may react with moisture or any impurity present.

Reactivity of alkyl halides with magnesium is in the following order:

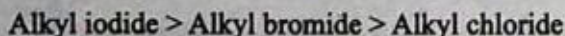

And for a given halogen the order of reactivity is as follows:

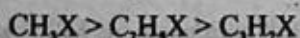

## Structure and Reactivity

Grignard reagents are much more reactive than most of the organic compounds. The reactivity is due to the nature of C-Mg bond which is highly polar.



Magnesium is more electropositive than carbon and the C-Mg bond though covalent is highly polar, giving alkyl carbon the partial negative charge. This negative charge is of an unusual character which makes the alkyl groups highly reactive towards electrophile centres. Mostly reactions shown by Grignard reagent are exothermic.

## Reactions

## (i) With water

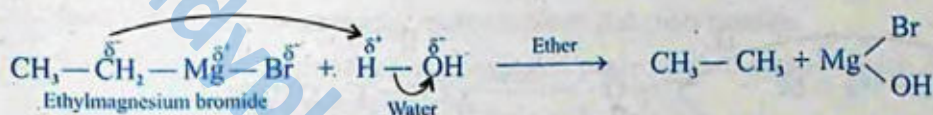

## (ii) With ammonia

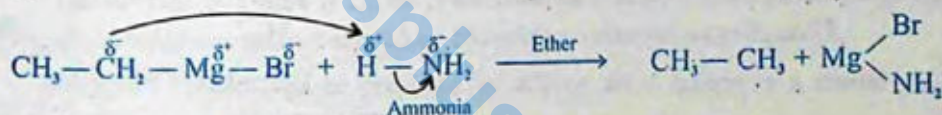

## (iii) With cyanogen chloride

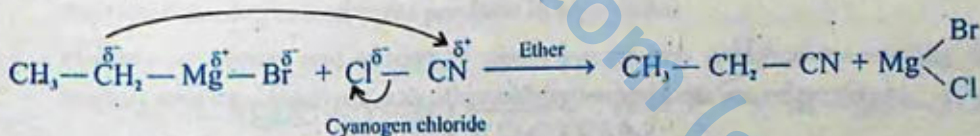

## (iv) With alcohols

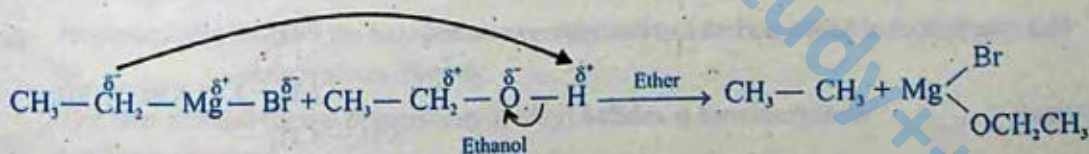
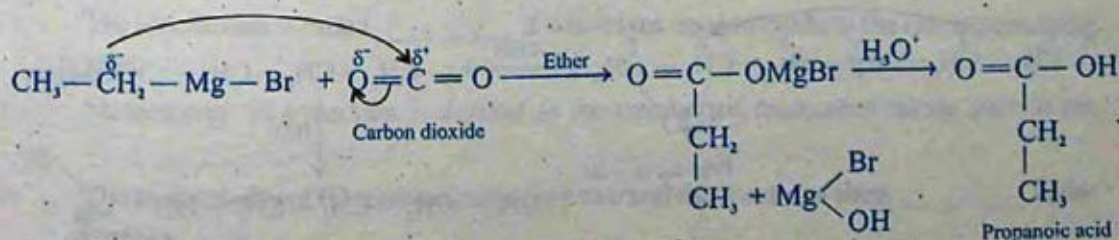
(v) With CO<sub>2</sub>

## (vi) With HCHO

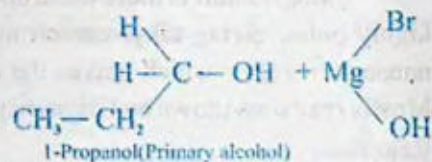
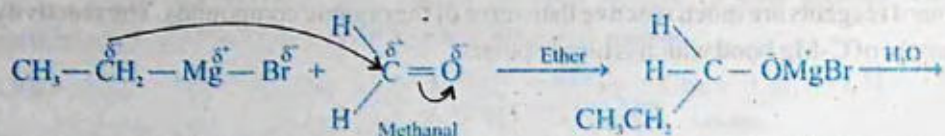
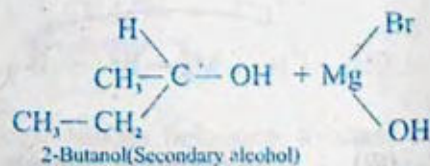
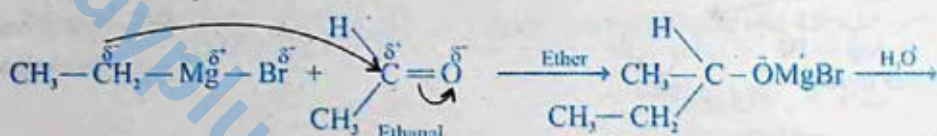
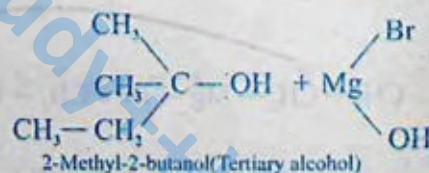
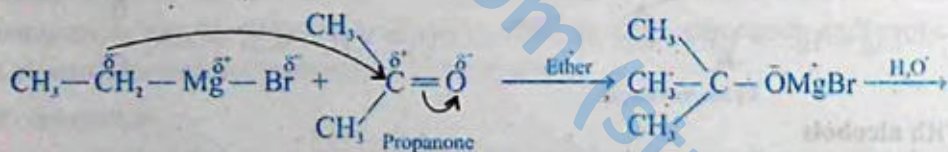
(vii) With CH<sub>3</sub>CHO(viii) With CH<sub>3</sub>COCH<sub>3</sub>

## (ix) With Epoxide

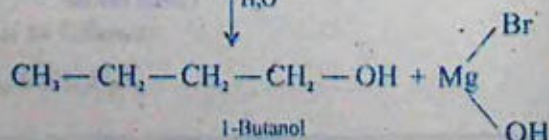
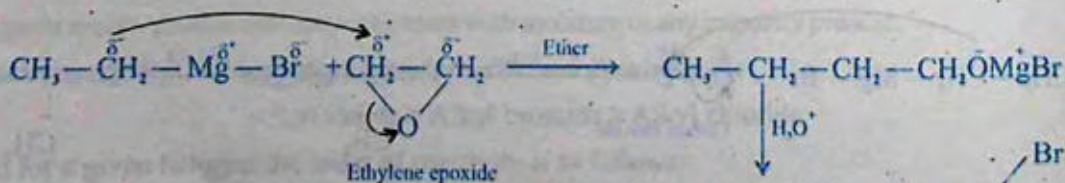

## KEY POINTS

1. Monohalo derivatives of alkanes are called alkyl halides.
2. The general formula of alkyl halides is  $C_nH_{2n+1}X$ .
3. The best method for the preparation of alkyl halides is by the reactions of alcohols with inorganic halides like  $SOCl_2$ ,  $PX_3$  and  $PX_5$ .
4. Alkyl halides are very reactive class of organic compounds. They undergo nucleophilic substitution reactions and elimination reactions in the presence of a nucleophile or a base.
5. Nucleophilic substitution reactions can take place in two distinct ways. A one step mechanism is called  $S_N2$  while a two step mechanism is called  $S_N1$ .  $S_N1$  reactions show first order kinetics whereas  $S_N2$  reactions show 2nd order kinetics.
6. Nucleophilic substitution reactions take place simultaneously with elimination reactions and often compete with them.
7. Elimination of two atoms or groups from adjacent carbon atoms in the presence of a nucleophile or a base is called  $\beta$ -elimination reaction. Like nucleophilic substitution, ( $\beta$ -elimination reaction also takes place in two distinct ways  $E_2$  and  $E_1$ ).
8. Grignard reagent can be prepared by adding alkyl halide in a stirred suspension of magnesium metal in diethyl ether.
9. Grignard reagent has a reactive nucleophilic carbon atom which can react with electrophilic centres to give the products in high yields.
10. Primary, secondary and tertiary alcohols can be best prepared by reacting Grignard reagent with formaldehyde, any other aldehydes and ketones, respectively.

## EXERCISE

### Q.1. Fill in the blanks.

- i) In tertiary alkyl halides the halogen atom is attached to a carbon which is further attached to \_\_\_\_\_ carbon atoms directly.
- ii) The best method for the preparation of alkyl halides is the reaction of \_\_\_\_\_ with inorganic reagents.
- iii) An alkyl group with a partial positive charge on the carbon atom is called \_\_\_\_\_ centre.
- iv) The mechanism is called \_\_\_\_\_ if it involves one molecule in the rate determining step.
- v) Molecularity of a reaction is defined as the number of molecules taking part in the \_\_\_\_\_.
- vi) The molecularity of  $E_2$  reactions is always two and the reactions show \_\_\_\_\_ order kinetics.

- vii) Wurtz synthesis is useful for the preparation of \_\_\_\_\_ alkanes.
- viii) Grignard reagents are prepared by the reaction of magnesium metal with alkyl halides in the presence of \_\_\_\_\_.

**Q.2. Indicate True or False.**

- i) In secondary alkyl halides, the halogen atom is attached to a carbon which is further attached to two carbon atoms directly.
- ii) Alcohols react with thionyl chloride in ether as solvent to give alkyl halides.
- iii) Order of reactivity of alkyl halides for a particular alkyl group is:  
Iodide > Bromide > Chloride > Fluoride
- iv) In  $S_N2$  reactions the attacking nucleophile always attacks from the side in which the leaving group is attached.
- v) Methyl magnesium iodide on hydrolysis yields ethyl alcohol.
- vi) Primary, secondary and tertiary amines react with Grignard reagents in the same way.
- vii) The reactions of secondary alkyl halides may follow both  $S_N1$  and  $S_N2$  mechanisms.
- viii)  $S_N1$  mechanism is a one stage process involving a simultaneous bond breakage and bond formation.
- ix) In  $\beta$ -elimination reactions, the two atoms or groups attached to two adjacent carbon atoms are lost under the influence of an electrophile.
- x) The reactivity order of alkyl halides is determined by the strength of carbon halogen bond.

**Q.3. Multiple choice questions. Encircle the correct answer.**

- i) In primary alkyl halides, the halogen atom is attached to a carbon which is further attached to \_\_\_\_\_ carbon atom(s). Indicate the number.  
(a) Two (b) Three (c) One (d) Four
- ii) The reactivity order of alkyl halides for a particular alkyl group is:  
(a) Fluoride > Chloride > Bromide > Iodide  
(b) Chloride > Bromide > Fluoride > Iodide  
(c) Iodide > Bromide > Chloride > Fluoride  
(d) Bromide > Iodide > Chloride > Fluoride
- iii) When  $CO_2$  is made to react with ethyl magnesium iodide, followed by acid hydrolysis, the product formed is:  
(a) Propane (b) Propanoic acid  
(c) Propanal (d) Propanol
- iv) Grignard reagent is reactive due to:  
(a) the presence of halogen atom (b) the presence of Mg atom  
(c) the polarity of C-Mg bond (d) none of the above

- v)  $S_N2$  reactions can be best carried out with:
- (a) Primary alkyl halides (b) Secondary alkyl halides  
(c) Tertiary alkyl halides (d) All the three
- vi) Elimination bimolecular reactions involve:
- (a) first order kinetics (b) second order kinetics  
(c) third order kinetics (d) zero order kinetics
- vii) For which mechanisms, the first step involved is the same.
- (a) E1 and E2 (b) E2 and  $S_N2$   
(c)  $S_N1$  and E2 (d) E1 and  $S_N1$
- viii) Alkyl halides are considered to be very reactive compounds towards nucleophiles, because:
- (a) they have an electrophilic carbon  
(b) they have an electrophilic carbon and a good leaving group  
(c) they have an electrophilic carbon and a bad leaving group  
(d) they have a nucleophilic carbon and a good leaving group
- ix) The rate of E1 reaction depends upon:
- (a) the concentration of substrate  
(b) the concentration of nucleophile  
(c) the concentration of substrate as well as nucleophile  
(d) None of the above
- x) Which one of the following is not a nucleophile:
- (a)  $H_2O$  (b)  $H_2S$   
(c)  $BF_3$  (d)  $NH_3$

Q.4. Define alkyl halide. Which is the best method of preparing alkyl halides?

Q.5. Write down a method for the preparation of ethyl magnesium bromide in laboratory.

Q.6. Give IUPAC names to the following compounds:

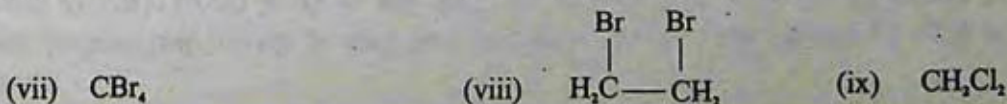
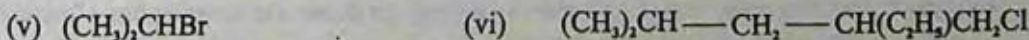
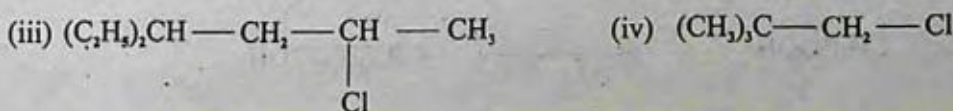
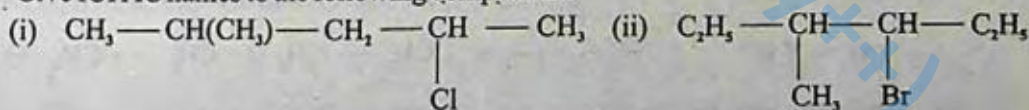

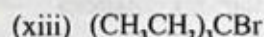
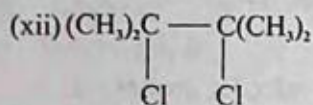
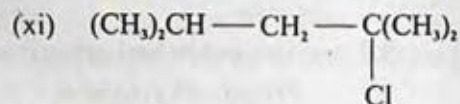
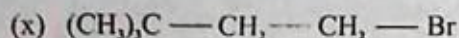

Q.7. Draw all the possible structures that have the molecular formula  $\text{C}_4\text{H}_9\text{Cl}$ . Classify each as primary, secondary or tertiary chloride. Give their names according to IUPAC system.

Q.8. Using ethyl bromide as a starting material how would you prepare the following compounds. Give also the inorganic reagents and conditions necessary to carry out these reactions:

- |                   |                    |
|-------------------|--------------------|
| (a) n-Butane      | (b) Ethyl alcohol  |
| (c) Ethyl cyanide | (d) Ethane         |
| (e) Ethene        | (f) Propanoic acid |
| (g) Propane       |                    |

Q.9. Write a detailed note on the mechanism of nucleophilic substitution reactions.

Q.10. What do you understand by the term  $\beta$ -elimination reaction. Explain briefly the two possible mechanisms of  $\beta$ -elimination reactions.

Q.11. What products are formed when the following compounds are treated with ethyl magnesium bromide, followed by hydrolysis in the presence of an acid?

- |                                 |  |                     |
|---------------------------------|--|---------------------|
| (i) HCHO                        | (ii) $\text{CH}_3\text{CHO}$                 | (iii) $\text{CO}_2$ |
| (iv) $(\text{CH}_3)_2\text{CO}$ | (v) $\text{CH}_3 - \text{CH}_2 - \text{CHO}$ | (vi) $\text{ClCN}$  |

Q.12. How will you carry out the following conversions?

- |  |                   |   |
|--|-------------------|---|
| i) $\text{CH}_4$                                 | $\longrightarrow$ | $\text{CH}_3\text{CH}_2\text{COOH}$                                 |
| ii) $\text{CH}_3 - \text{CH}_3$                  | $\longrightarrow$ | $(\text{CH}_3 - \text{CH}_2)_4\text{N}^+\text{Br}^-$                |
| iii) $\text{CH}_2 = \text{CH}_2$                 | $\longrightarrow$ | $\text{CH}_3 - \text{CH}_2 - \text{CH}_2 - \text{CH}_2 - \text{OH}$ |
| iv) $\text{CH}_3\text{CH}_2\text{CH}_2\text{Cl}$ | $\longrightarrow$ | $\text{CH}_3 - \text{CH} = \text{CH}_2$                             |
| v) $\text{CH}_3\text{COOH}$                      | $\longrightarrow$ | $\text{CH}_3\text{CH}_2\text{COOH}$                                 |

## CHAPTER

## 11

## ALCOHOLS, PHENOLS AND ETHERS

In this chapter you will learn

1. How to name simple monohydric and polyhydric alcohols and their classification as primary, secondary and tertiary alcohols.
2. The important synthetic reactions leading to alcohols and industrial processes for the manufacture of methanol and ethanol.
3. The nature of OH group and its reactivity when O-H bond is broken and when C-O bond is broken.
4. To distinguish chemically between the primary, secondary and tertiary alcohols.
5. The methods of preparation of phenol and its acidic nature.
6. The importance of phenol as starting material for the preparation of five industrially important compounds.
7. How to name ethers and preparation of diethyl ether.
8. The physical and chemical behaviour of diethyl ether and its inertness towards chemical reagents.

## 11.1 INTRODUCTION

Alcohols, phenols and ethers are classes of organic compounds which are much closer to water in structure and hence considered as derivatives of water.

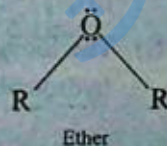
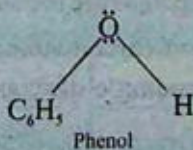
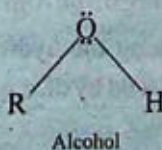
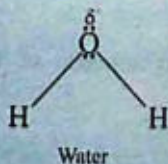

Alcohols and phenols are much more close to one another in structure and properties. Both contain hydroxyl (-OH) group so they may also be termed as hydroxyl derivatives of alkanes and benzene respectively. In ether both hydrogens of water are replaced by alkyl or phenyl groups.

## 11.2 ALCOHOLS

They are represented by a general formula ROH where R is an alkyl group which may be  $\text{CH}_3-$ ,  $\text{CH}_3\text{CH}_2-$ ,  $(\text{CH}_3)_2\text{CH}-$  and  $\text{C}_6\text{H}_5-\text{CH}_2-$ , etc.

### Classification

Alcohols are classified into monohydric and polyhydric alcohols. Monohydric alcohols contain one -OH group while polyhydric alcohols may contain two, three or more OH groups and named as dihydric or trihydric alcohols, etc.

Monohydric alcohols are further classified into primary, secondary and tertiary alcohols. In primary alcohols, -OH functional group is attached with primary carbon atom, in secondary alcohols with secondary carbon atom and in tertiary alcohols it is attached with a tertiary carbon atom.

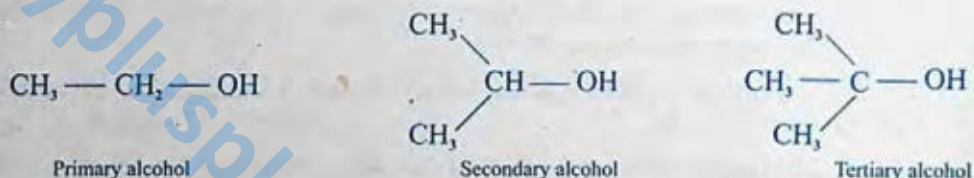

### 11.2.1 NOMENCLATURE OF ALCOHOLS

There are two systems of naming alcohols.

#### Common or Trivial Names

- (a) Lower and simpler alcohols are usually known by their common or trivial names, obtained by adding the name of alcohol after the name of the alkyl group to which the OH group is attached, e.g.,

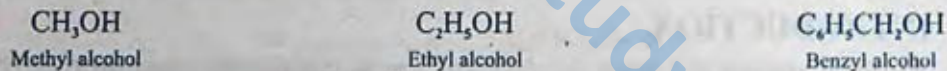

#### (b) IUPAC Names

In this system the alcohols are named according to the following rules.

- (i) The longest chain of carbon atoms containing the hydroxyl group is taken as parent hydrocarbon. The ending 'e' of alkane is replaced by ol, e.g;

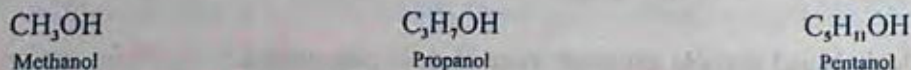

- (ii) The position of OH group is indicated by a number placed before the name. The carbon chain is numbered, starting from the end where carbon atom attached with OH group

gets the lowest possible number, e.g;



1-Butanol

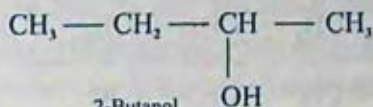

2-Butanol

- (iii) If more than one OH groups are attached, they are indicated by an appropriate suffix diol, triol, etc., e.g;

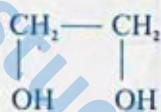

1,2-Ethandiol (Glycol)

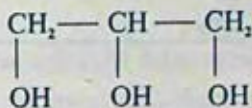

1,2,3-Propanetriol (Glycerol)

- (iv) The unsaturated alcohols are numbered in such a way that hydroxyl group rather than the point of unsaturation gets the lower number, e.g.;

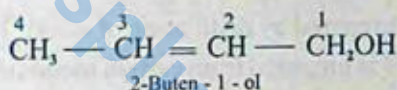

- (v) When hydroxyl group is not a preferred functional group as in hydroxy acids, aldehydes and ketones, the substituent name hydroxy is used as a prefix to indicate the position of OH group, e.g.;

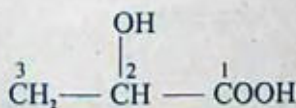
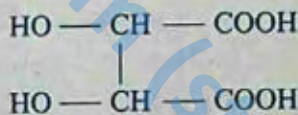
2-Hydroxy Propanoic Acid  
(Lactic Acid)2,3-Dihydroxy butane-1, 4-dioic acid  
(Tartaric Acid)

The names of some alcohols in the two systems are given below:

Formula	Common Name	IUPAC Name
$\text{CH}_3\text{OH}$	Methyl alcohol	Methanol
$\text{CH}_3\text{CH}_2\text{OH}$	Ethyl alcohol	Ethanol
$\text{CH}_3\text{CH}_2\text{CH}_2\text{OH}$	n-Propyl alcohol	1-Propanol
$\begin{array}{c} \text{CH}_3 \\ \diagdown \\ \text{CH} - \text{OH} \\ \diagup \\ \text{CH}_3 \end{array}$	Isopropyl alcohol	2-Propanol

Formula	Common Name	IUPAC Name
$\text{CH}_3 - \text{CH}_2 - \text{CH}_2 - \text{CH}_2 - \text{OH}$	n-Butyl alcohol	1-Butanol
$\begin{array}{c} \text{CH}_3 - \text{CH} - \text{CH}_2 - \text{OH} \\   \\ \text{CH}_3 \end{array}$	Iso-Butylalcohol	2-Methyl-1-propanol
$\begin{array}{c} \text{CH}_3 - \text{CH}_2 - \text{CH} - \text{OH} \\   \\ \text{CH}_3 \end{array}$	sec-Butylalcohol	2-Butanol
$\begin{array}{c} \text{CH}_3 \\   \\ \text{CH}_3 - \text{C} - \text{OH} \\   \\ \text{CH}_3 \end{array}$	Ter-Butyl alcohol	2-Methyl-2-propanol

### 11.2.2 Industrial Preparation of Alcohols

#### Methanol

Formerly methanol was prepared by distillation of wood. That is why it is also called as wood spirit. Nowadays methanol is prepared from carbon monoxide and hydrogen or water gas as follows:

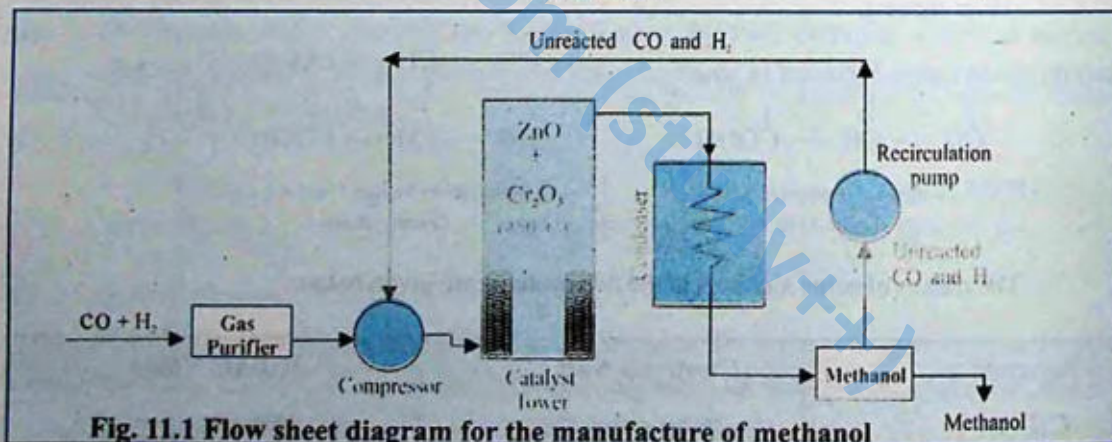
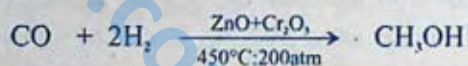

**Fig. 11.1** Flow sheet diagram for the manufacture of methanol

First of all a mixture of carbon monoxide and hydrogen is purified. It is compressed under a pressure of 200 atmospheres and taken into a reaction chamber by means of coiled pipes. Here the catalyst is heated upto 450-500 °C. Gases react to form methanol vapours. These vapours are passed through a condenser to cool the methanol. Unreacted gases are recycled through compressor to reaction chamber.

## Ethanol

Ethanol is prepared on industrial scale world over, by the process of fermentation. Fermentation is a biochemical process which occurs in the presence of certain enzymes secreted by microorganisms such as yeast. Optimum temperature for this process of fermentation is 25-35°C. Moreover, proper aeration, dilution of solution and the absence of any preservative are essential conditions for fermentation.

In Pakistan ethanol is prepared by the fermentation of molasses, starch grains or fruit juices.

### From Molasses

The residue obtained after the crystallization of sugar from concentrated sugar cane juice is called molasses. It undergoes fermentation in the presence of enzymes present in yeast to give ethanol.

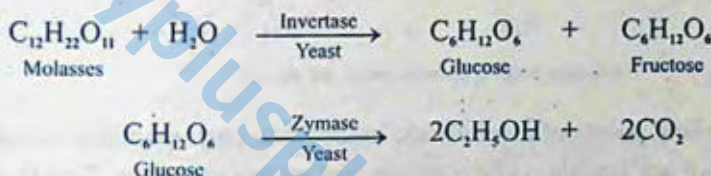

### From Starch

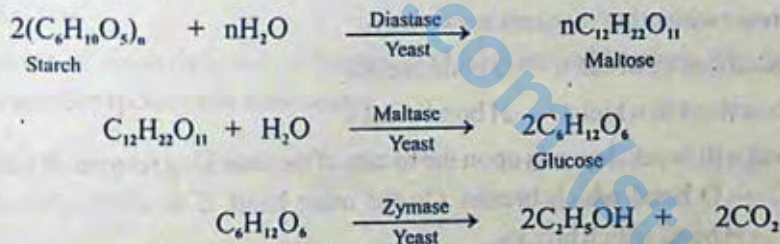

Alcohol obtained by fermentation is only upto 12% and never exceeds 14% because beyond this limit enzymes become inactive. This alcohol is distilled again and again to obtain 95% alcohol which is called rectified spirit. Absolute alcohol can also be obtained by redistillation of rectified spirit in the presence of CaO which absorbs its moisture.

### Denaturing of Alcohol

Sometimes ethanol is denatured by addition of 10% methanol to avoid its use for drinking purposes. Such alcohol is called methylated spirit. A small quantity of pyridine or acetone may also be added for this purpose.

### Other Methods of Preparation of Alcohols

Alcohols can be obtained by the hydration of alkenes and by the reaction of Grignard reagents with aldehydes or ketones. Both these methods have already been discussed in the previous chapter.

### 11.2.3 Physical Properties

Lower alcohols are generally colourless toxic liquids with characteristic sweet smell and burning taste. They are readily soluble in water but solubility decreases in higher alcohols. The solubility of alcohols is due to hydrogen bonding which is prominent in lower alcohols but diminishes in higher alcohols.

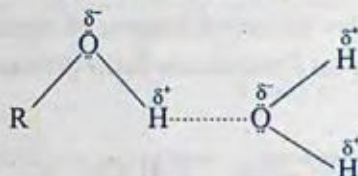
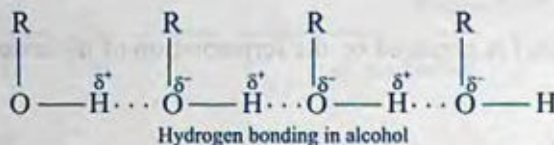

Melting and boiling points of alcohols are higher than corresponding alkanes. Methyl alcohol and ethyl alcohol are liquids while methane and ethane are gases. This is also due to hydrogen bonding which is present in alcohols but absent in alkanes.

### 11.2.4 Reactions of Alcohols

Alcohols react with other reagents in two ways

- (i) Reactions in which C—O bond breaks
- (ii) Reactions in which O—H bond breaks

Which bond will break depends upon the nature of the attacking reagent. If a nucleophile attacks, it is the C—O bond which breaks. On the other hand, if an electrophile attacks on alcohol, it is the O—H bond which breaks.

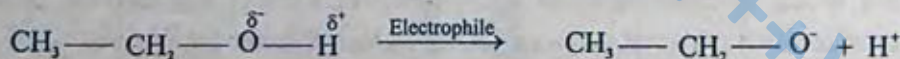
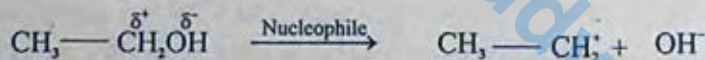

The order of reactivity of alcohols when C—O bond breaks:

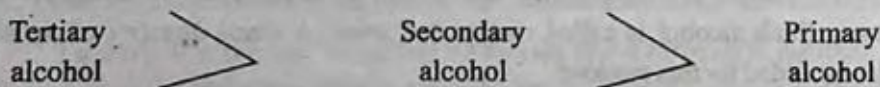

The order of reactivity of alcohols when O—H bond breaks:





**(ii) Dehydration**

Alcohols react with conc.  $\text{H}_2\text{SO}_4$  and give different products at different temperatures.

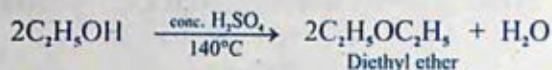
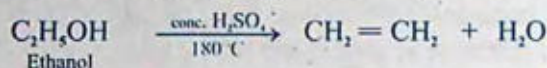
**(iii) Reactions with Phosphorus Halides  $\text{PCl}_3$ ,  $\text{PCl}_5$** **11.3 DISTINCTION BETWEEN PRIMARY, SECONDARY AND TERTIARY ALCOHOLS****Lucas Test**

Primary, secondary and tertiary alcohols are identified and distinguished by reacting them with con.  $\text{HCl}$  in anhydrous  $\text{ZnCl}_2$ . An oily layer of alkyl halides separates out in these reactions.

1. Tertiary alcohols form an oily layer immediately
2. Secondary alcohols form an oily layer in five to ten minutes.
3. Primary alcohols form an oily layer only on Heating

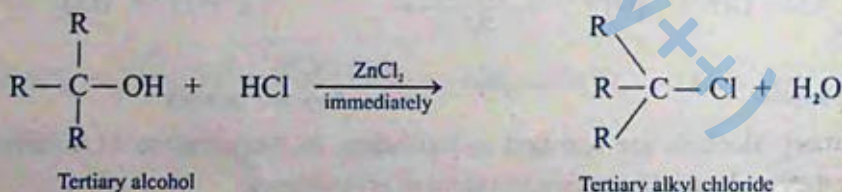
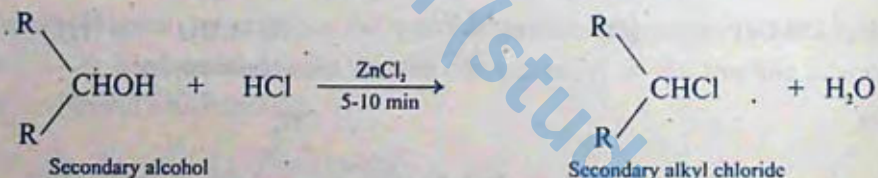
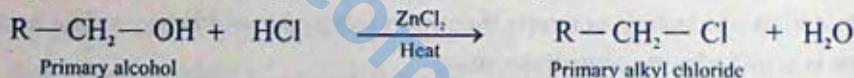
**Distinction between Methanol and Ethanol**

Ethanol forms iodoform with iodine in the presence of  $\text{NaOH}$ . Formation of yellow crystals indicate that the alcohol is ethanol. Methanol does not give iodoform test.

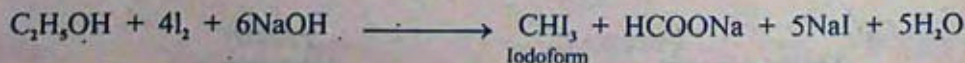

## 11.4 USES OF ALCOHOLS

Methanol is used as a solvent for fats oils, paints, varnishes. It is also used as antifreeze in the radiators of automobiles and for denaturing of alcohol. Ethanol is used as a solvent, as a drink and as a fuel in some countries. Moreover, it is used in pharmaceutical preparations and as a preservative for biological specimens.

## 11.5 PHENOL

Aromatic compounds which contain one or more OH groups directly attached with carbon of benzene ring are called Phenols. The simplest example is phenol which is also known as Carboic acid i.e.  $C_6H_5OH$ . It was first obtained from coaltar by Runge in 1834.

### 11.5.1 Preparation of Phenol

#### 1) From Chlorobenzene (Dow's Method)

In this method chlorobenzene is treated with 10% NaOH at  $360^\circ\text{C}$  and 150 atmospheres pressure. Sodium phenoxide is produced which on treating with HCl gives phenol.

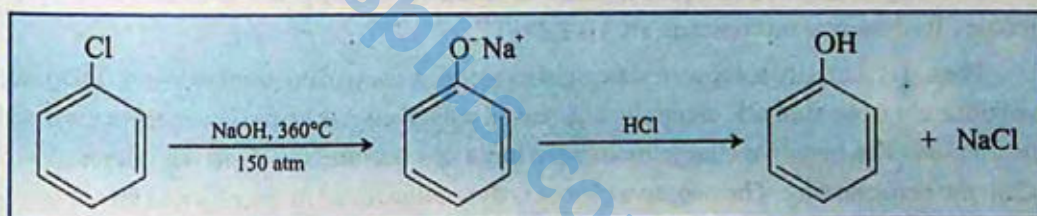

#### 2) From Sodium Salt of Benzene Sulphonic Acid

Sodium salt of benzene sulphonic acid reacts with NaOH at  $320^\circ\text{C}$  to give sodium phenoxide which on treatment with HCl gives phenol.

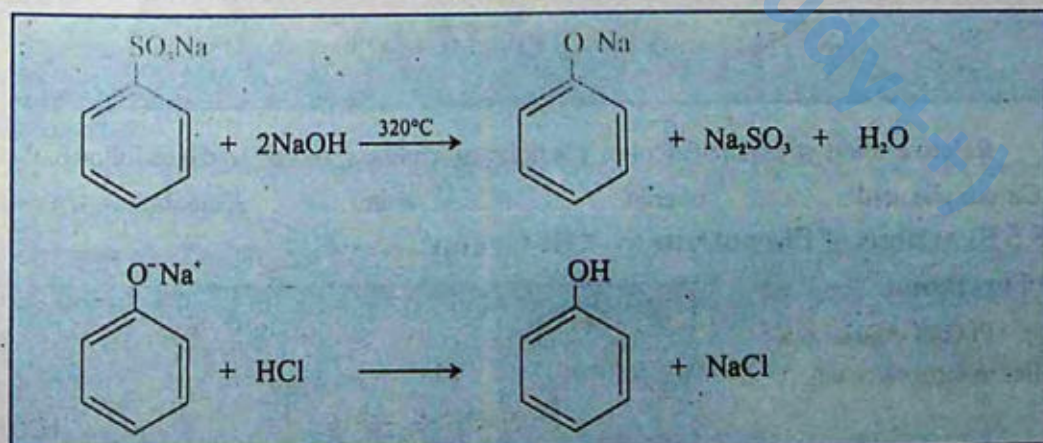

The phenol is recovered by steam distillation.

### 11.5.2 Physical Properties

Phenol is a colourless, crystalline, deliquescent solid with characteristic phenolic odour having melting point  $41^{\circ}\text{C}$  and boiling point  $182^{\circ}\text{C}$ . It is sparingly soluble in water forming pink solution at room temperature but completely soluble above  $68.5^{\circ}\text{C}$ . It is poisonous and used as a disinfectant in hospitals and washrooms.

### 11.5.3 Reactions of Phenol

Phenol shows two type of reactions.

1. Reactions due to —OH group
2. Reactions due to benzene ring

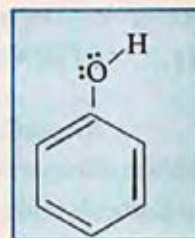

Phenols are less reactive to nucleophiles so nucleophilic attack is less favoured, i.e. -OH is not easy to replace while electrophilic attack on the ring is easy.

### 11.5.4 Acidic Behaviour of Phenol

Phenol is much more acidic than alcohols but less acidic than carboxylic acids. It dissolves readily in alkalis but it is too weak to affect the litmus paper or to evolve  $\text{CO}_2$  from carbonates. Its dissociation constant ( $K_a$ ) is  $1.3 \times 10^{-10}$ .

Phenol is partially soluble in water and its solution has a pH of around 5 or 6. This makes phenol different from aliphatic alcohols. The reason why phenol is acidic lies in the nature of the phenoxide ion. The negative charge on oxygen atom can become involved with the  $\pi$ -electron cloud on the benzene ring. The negative charge is thus delocalized in the ring and the phenoxide ion becomes relatively stable. This type of delocalization is not possible with alcohols.

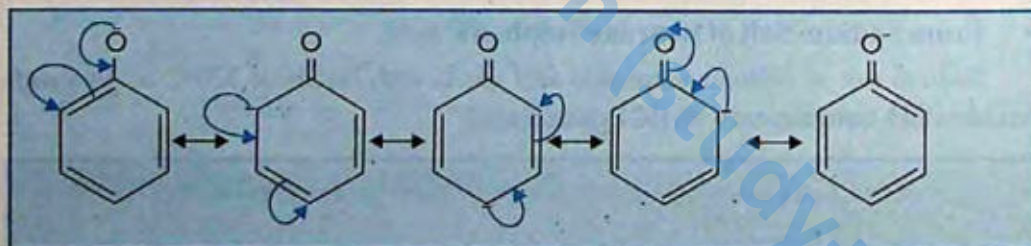

Relative acidic strength of alcohol, phenol, water and carboxylic acid is as follows,



### 11.5.5 Reactions of Phenol Due to -OH Group

#### Salt Formation

Phenol reacts with alkalis to form salts, e.g;

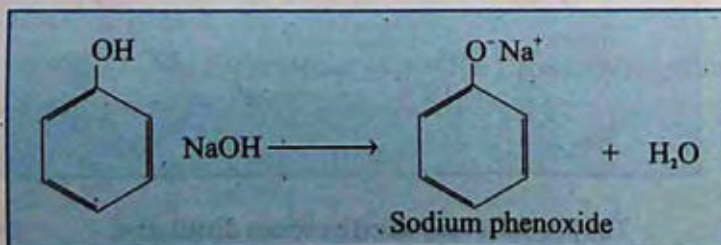

**Ester Formation**

Phenol reacts with acetyl chloride in the presence of a base to form ester.

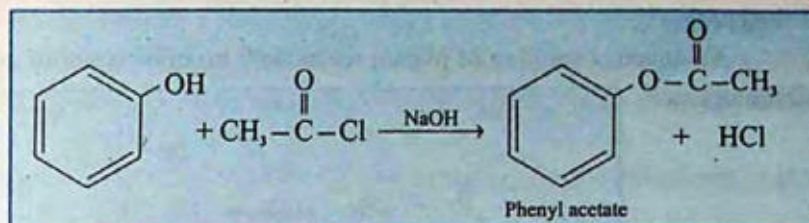
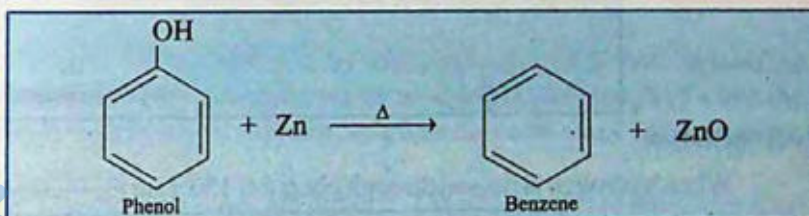
**Reduction with Zn****11.5.6 Reactions of Phenol Due to Benzene Ring****Nitration**

Phenol reacts with dil. and conc.  $\text{HNO}_3$  at different temperatures as follows:

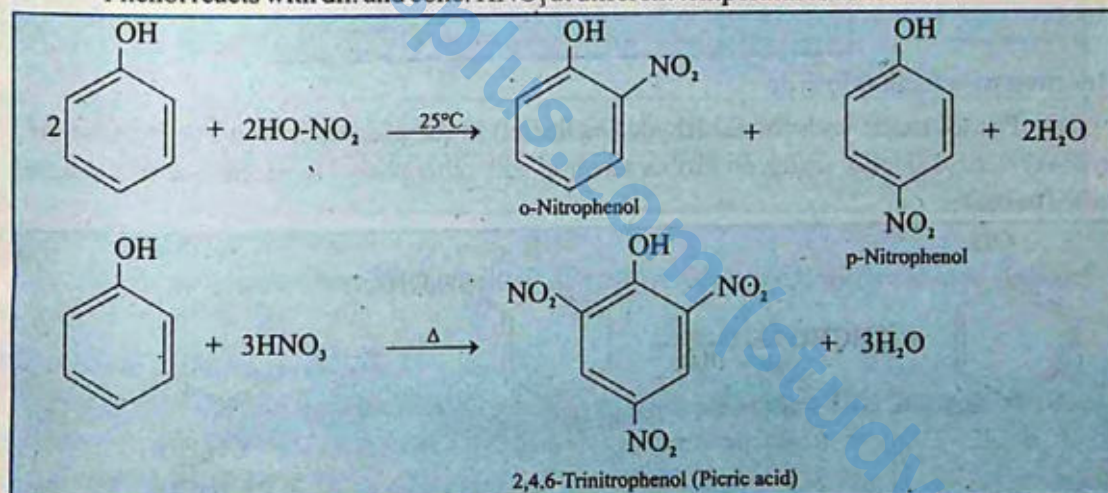
**Sulphonation**

Phenol reacts with conc.  $\text{H}_2\text{SO}_4$  at room temperature giving ortho and para hydroxy benzene sulphonic acids.

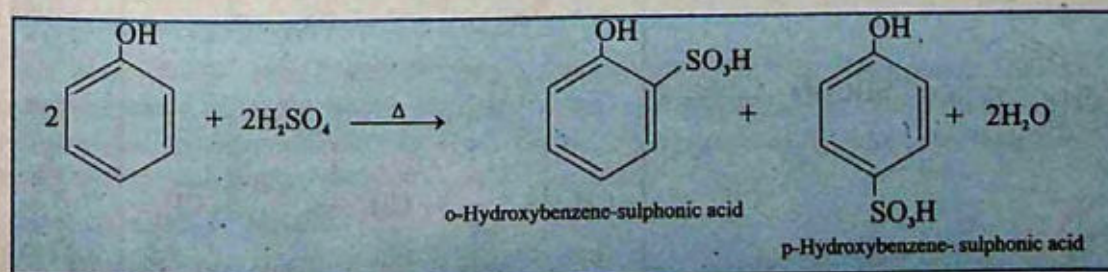

**Halogenation**

An aqueous solution of phenol reacts with bromine water to give white ppt. of 2,4,6-tribromophenol.

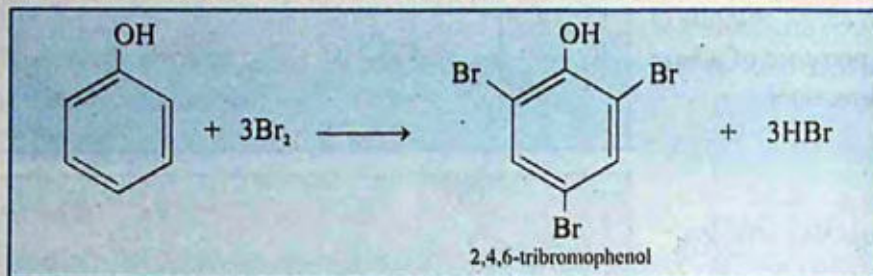
**Hydrogenation**

When hydrogen is passed through phenol at 150°C in the presence of Ni catalyst, it gives cyclohexanol.

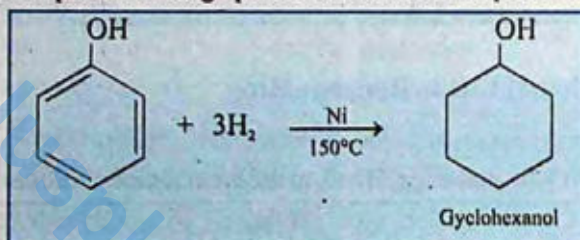
**Reaction with formaldehyde**

Phenol reacts with formaldehyde (methanal) in the presence of acid or alkali to give hydroxy benzyl alcohol which on further reaction with other phenol molecules yields a polymer called bakelite.

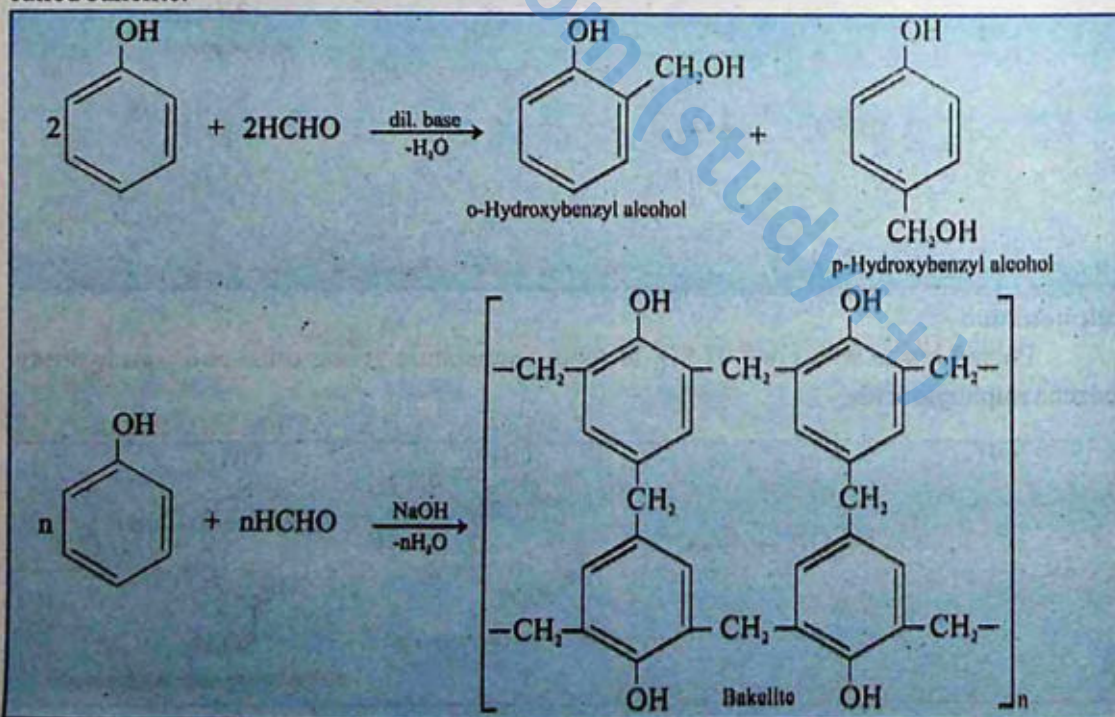

## 11.6 ETHERS

Ethers are classified into two categories

- Simple or symmetrical ethers, which contain two same alkyl groups, e.g., dimethyl ether  $\text{CH}_3\text{OCH}_3$ , and diethyl ether  $\text{CH}_3-\text{CH}_2-\text{O}-\text{CH}_2-\text{CH}_3$ .
- Mixed or unsymmetrical ethers, which contain different alkyl or phenyl groups, e.g., ethyl methyl ether  $\text{CH}_3-\text{O}-\text{CH}_2-\text{CH}_3$ .

### 11.6.1 Nomenclature

Ethers are named either by IUPAC system or by common names. In IUPAC system the large alkyl (R) group is taken as parent molecule and given the last name (suffix) while the smaller alkyl group along with oxygen is used as prefix and given the name alkoxy (e.g. methoxy, ethoxy, propoxy, etc).

IUPAC names are not common as they are difficult. Usually ethers are known by their common names, as given below;

Formula	Common Names	IUPAC System
$\text{CH}_3\text{OCH}_3$	Dimethyl ether	Methoxy methane
$\text{CH}_3\text{OC}_2\text{H}_5$	Ethyl methyl ether	Methoxy ethane
$\text{C}_2\text{H}_5\text{OC}_2\text{H}_5$	Diethyl ether	Ethoxy ethane
$\text{C}_2\text{H}_5\text{OCH}_2-\text{CH}_2-\text{CH}_3$	Ethyl n-propyl ether	Ethoxy Propane
$\text{CH}_3\text{OC}_6\text{H}_5$	Methyl phenyl ether	Methoxy benzene

### 11.6.2 Preparation of Ethers

Ethers are prepared from alcohols either directly or indirectly. Usually they are obtained by the following methods.

#### (i) By Williamsons synthesis

Alcohols are reacted with metallic sodium to form alkoxides. This alkoxide ion is a strong nucleophile and readily reacts with alkyl halide to produce an ether.

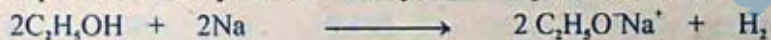

#### (ii) Alkyl halides are heated with dry silver oxide to form ethers



### 11.6.3 Physical Properties

Usually ethers are volatile liquids, highly inflammable with low boiling points. They are slightly soluble in water but freely soluble in organic solvents. Ether molecules do not show hydrogen bonding with one another but they show weak hydrogen bonding with water molecules due to which they are slightly soluble in water.

### 11.6.4 Chemical Reactivity

Ethers are comparatively inert substances. The reagents like ammonia, alkalies, dilute

acids and metallic sodium, have no action on ethers in cold state. Moreover, they are not oxidized or reduced easily. However ethers show some reactions, e.g.

1. With hydrogen iodide, ethers give alcohols which can react further to give alkyl iodides.

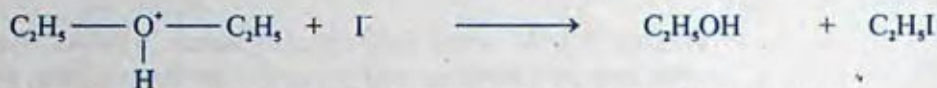
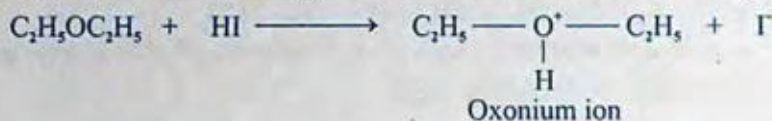

2. Ethers also react with hot phosphorus pentachloride to give alkyl chloride.



### KEY POINTS

- Alcohols and Phenols are hydroxy derivatives of aliphatic and aromatic hydrocarbons.
- General formula for alcohol is ROH, for Phenol is Ph OH, and for ether it is ROR.
- Alcohols are usually named by replacing 'e' for the alkane with 'ol'.
- In Pakistan ethanol is prepared commercially from molasses.
- Fermentation is a biochemical phenomenon which may occur naturally or artificially.
- Ethyl alcohol obtained by fermentation is less than 12% concentrated.
- Ethyl alcohol gives different products when reacts with  $\text{H}_2\text{SO}_4$  of different concentrations.
- Ethyl alcohol is used as a solvent, as a beverage and as a fuel.
- Primary, secondary and tertiary alcohols can be distinguished by Lucas test.
- Picric acid is a phenol which behaves like an acid.

### EXERCISE

#### Q.1. Fill in the Blanks.

- Primary, secondary and tertiary alcohols can be identified by \_\_\_\_\_ test.
- Oxidation of \_\_\_\_\_ alcohols give ketones.
- Alcohols on heating with \_\_\_\_\_ give alkenes at high temperature.
- Alcohols have \_\_\_\_\_ boiling points than ethers due to stronger hydrogen bonding.
- Williamsons synthesis is used to prepare \_\_\_\_\_.
- \_\_\_\_\_ is also called wood spirit.
- Carbolic acid is the other name of \_\_\_\_\_.
- Primary, secondary and tertiary alcohols can be prepared by reacting Grignard reagent with \_\_\_\_\_, \_\_\_\_\_ and \_\_\_\_\_ respectively.

- ix. Alcohols and \_\_\_\_\_ react to produce esters.
- x. \_\_\_\_\_ is used as anti-freezing agent in automobile radiator.
- xi. The process of conversion of starch into alcohol with the help of microorganisms is called \_\_\_\_\_.
- xii. Ketones on reduction give \_\_\_\_\_ alcohols.

### Q.2. Indicate True or False.

- i. Methylated spirit contains 95% methyl alcohol and 5% ethyl alcohol.
- ii. Ethyl alcohol is a very good anti-freezing agent.
- iii. Methanol is also called wood spirit.
- iv. Only 14% ethyl alcohol can be prepared by fermentation.
- v. Ethers do not show hydrogen bonding.
- vi. Alcohols are more acidic than phenols.
- vii. Phenol is more soluble in water than lower alcohols.
- viii. Alcohols are more basic than ethers.
- ix. Ethers have higher boiling points than alcohols and phenols.
- x. Methanol and ethanol can be distinguished by iodoform test.

### Q.3. Multiple Choice Questions. Encircle the correct answer.

- i) Which compound shows hydrogen bonding?
- a)  $C_2H_6$     b)  $C_2H_5Cl$     c)  $CH_3-O-CH_3$     d)  $C_2H_5OH$
- ii) Which compound shows maximum hydrogen bonding with water?
- a)  $CH_3OH$     b)  $C_2H_5OH$     c)  $CH_3-O-CH_3$     d)  $C_6H_5OH$
- iii) Which compound is more soluble in water?
- a)  $C_2H_5OH$     b)  $C_6H_5OH$     c)  $CH_3COCH_3$     d) n-Hexanol
- iv) Which compound will have the maximum repulsion with  $H_2O$ ?
- a)  $C_6H_6$     b)  $C_2H_5OH$     c)  $CH_3CH_2CH_2OH$     d)  $CH_3-O-CH_3$
- v) Ethanol can be converted into ethanoic acid by:
- a) Hydrogenation    b) Hydration  
c) Oxidation    d) Fermentation
- vi) Which enzyme is not involved in fermentation of starch?
- a) Diastase    b) Zymase  
c) Urease    d) Invertase
- vii) Which compound is called a universal solvent?
- a)  $H_2O$     b)  $CH_3OH$   
c)  $C_2H_5OH$     d)  $CH_3-O-CH_3$

- viii) Methyl alcohol is not used:
- a) as a solvent
  - b) as an anti-freezing agent
  - c) as a substitute for petrol
  - d) for denaturing of ethyl alcohol
- ix) Rectified spirit contains methyl alcohol about:
- a) 80%
  - b) 85%
  - c) 90%
  - d) 95%
- x) According to Lewis concept ethers behave as:
- a) acid
  - b) base
  - c) acid as well as a base
  - d) none of them

**Q.4.** What are alcohols? How are they classified? How will you distinguish between primary, secondary and tertiary alcohols?

**Q.5.** How is methyl alcohol obtained on large scale? How it may be distinguished from ethyl alcohol?

**Q.6.** What is fermentation? Which compound may be obtained on industrial scale by fermentation?

**Q.7.** Explain the following terms.

Absolute alcohol, Methylated spirit, Rectified spirit, Denaturing of alcohols.

**Q.8.** How does ethyl alcohol react with the following reagents?

- i) Conc.  $H_2SO_4$
- ii) Na
- iii)  $PCl_5$
- iv)  $CH_3COOH$
- v)  $SOCl_2$

**Q.9.** How will you obtain primary, secondary and tertiary alcohols by reacting Grignard reagent with suitable carbonyl compounds.

**Q.10.** How will you distinguish between:

- i) an alcohol and a phenol
- ii) an alcohol and an ether
- iii) methanol and ethanol
- iv) a tertiary alcohol and a primary alcohol
- v) 1-propanol and 2-propanol

**Q.11.** Give reasons for the followings:

- i) Ethyl alcohol is a liquid while methyl chloride is a gas.
- ii) Ethanol has higher boiling point than diethyl ether.
- iii) Absolute alcohol cannot be prepared by fermentation process.
- iv) Ethanol gives different products with conc.  $H_2SO_4$  under different conditions.
- v) Water has higher boiling point than ethanol.

**Q.12.** How will you convert?

- i) Methanol into ethanol
- ii) Ethanol into methanol
- iii) Ethanol into isopropyl alcohol
- iv) Formaldehyde into ethyl alcohol

v) Acetone into ethyl alcohol

**Q.13.** Explain the following terms using ethyl alcohol as an example.

- i) Oxidation      ii) Dehydration  
iii) Esterification      iv) Ether formation

**Q.14.** Compare the reactions of phenol with those of ethanol. Discuss the difference if any.

**Q.15.** Arrange the following compounds in order of their increasing acid strength and give reasons.

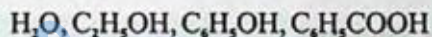

**Q.16.** Write down two methods for preparing phenol. What is the action of following on phenol?

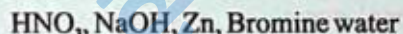

**Q.17.** Give the uses of phenols. How bakelite is prepared from it?

**Q.18.** (a) Write IUPAC names of the following compounds.

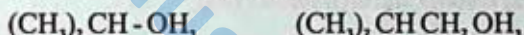

(b) Write structure formulas for the following compounds.

Glycol, Glycerol, Carboic acid, Acetophenone, Picric acid

**Q.19.** (a) Name the following compounds:

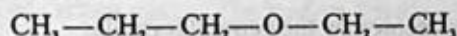
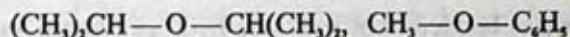

(b) Write down structural formulae of the following compounds.

Methoxy ethane, ethoxy benzene, sodium ethoxide, sodium phenoxide, propoxy propane.

## CHAPTER

## 12

## ALDEHYDES AND KETONES

## In this chapter you will learn

1. How to name aldehydes and ketones.
2. General methods for the preparation of aldehydes and ketones.
3. How are formaldehyde and acetaldehyde commercially prepared.
4. The relationship between structure and reactivity of carbonyl group.
5. The reactions of aldehydes and ketones and their mechanism.
6. How to identify aldehydes and ketones.
7. Tests for the distinction between aldehydes and ketones.

## 12.1 INTRODUCTION

Organic compounds containing the carbonyl functional group,  $\text{>C=O}$ , are called carbonyl compounds. In a carbonyl group, a carbon atom is bonded to oxygen with a double bond.

In aldehydes, the carbonyl group is bonded to at least one hydrogen atom, and so it occurs at the end of a chain. An aldehyde can be represented by the general formula:

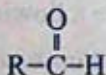

Where R may be H or an alkyl group.

In ketones, the carbonyl group is bonded to two carbon atoms, and so it occurs within a chain. A ketone may be represented by the general formula:

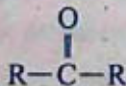

The homologous series of both aldehydes and ketones have the general formula,  $\text{C}_n\text{H}_{2n}\text{O}$ .

Aldehydes and ketones are present in many naturally occurring compounds. The aldehyde group is present in most sugars. They are the principal constituents of a number of essential oils used as fragrances and flavours. Ketonic group is present in camphor and menthone.

## 12.2 NOMENCLATURE

### a. Aldehydes

#### Common Names:

The common names of aldehydes are obtained from the common names of carboxylic acids containing the same number of carbon atoms. The ending -ic acid in the common name of the acid is replaced by the word aldehyde.

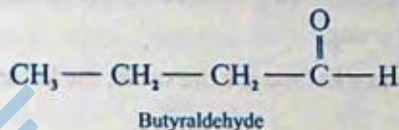
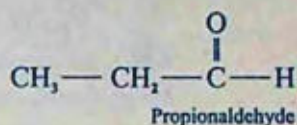
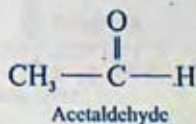
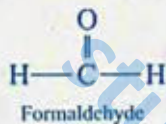

The positions of other groups on the chain are indicated by Greek letters ( $\alpha$ ,  $\beta$ ,  $\gamma$ ,  $\delta$ ). Lettering starts on the carbon adjacent to the carbonyl group.

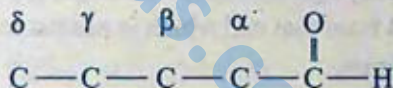

#### IUPAC Names:

The IUPAC names of aldehydes are derived from the names of alkanes having the same number of carbon atoms. The ending letter -e in the name of the alkane is replaced with al. The positions of other groups on the chain are indicated by using numbers. Numbering starts from the carbonyl carbon. Aromatic aldehydes are not given IUPAC names.

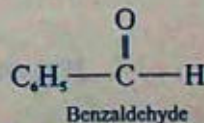
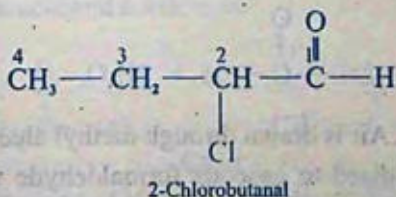
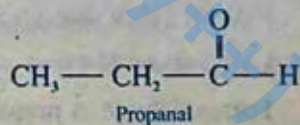
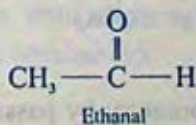
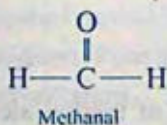

## b. Ketones

### Common Names

The common names of ketones are obtained by separately writing the names of the alkyl groups attached to the carbonyl carbon. The word ketone is then added as a separate word. The names of the alkyl groups are written alphabetically. When the two alkyl groups are the same, the prefix di- is added before the name of the alkyl group.

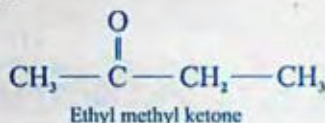
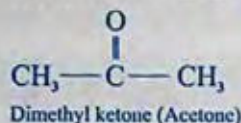

The positions of other groups are indicated by Greek letters, the  $\alpha$ -carbon atom being the one adjacent to the carbonyl group.

If the two alkyl groups in a ketone are the same, the ketone is said to be symmetrical, if unlike, unsymmetrical.

### IUPAC Names

The IUPAC names of ketones are derived from the names of alkanes having the same number of carbon atoms. The ending letter -e in the name of alkane is replaced with the suffix -one. The positions of the carbonyl group and of other groups on the chain are indicated by numbers. Numbering is started from that end which is nearest to the carbonyl group. Aromatic ketones are not given IUPAC names.

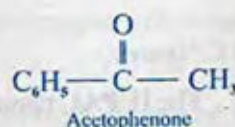
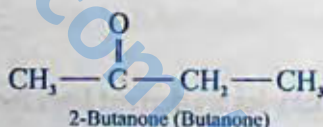
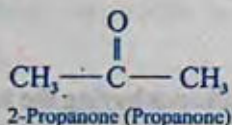

## 12.3 PREPARATION OF ALDEHYDES AND KETONES

Aldehydes are obtained by the oxidation of primary alcohols whereas ketones by the oxidation of secondary alcohols. Ketones are also prepared by hydration of alkynes.

### a. Preparation of Formaldehyde (Formalin)

#### (i) Laboratory Method

Formaldehyde is prepared in the laboratory by passing a mixture of methyl alcohol vapours and air over platinised asbestos or copper or silver catalyst at  $300^\circ\text{C}$ .

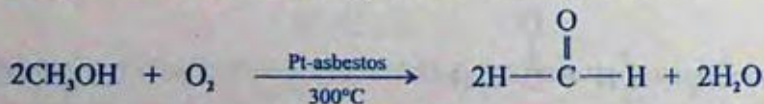

Set up the apparatus as shown in Fig. (12.1). Air is drawn through methyl alcohol with the help of a suction pump. Methyl alcohol is oxidised to gaseous formaldehyde which is absorbed in water. The resulting mixture is called formalin. Formalin is a mixture of 40% formaldehyde, 8% methyl alcohol and 52% water.

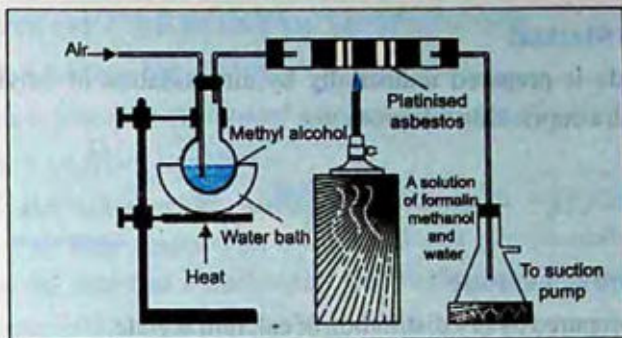
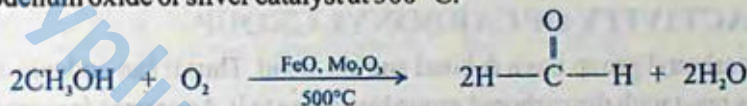

Fig. 12.1 Preparation of Formaldehyde (formalin)

## (ii) Industrial Method

Formaldehyde is manufactured by passing a mixture of methanol vapours and air over iron oxide-molybdenum oxide or silver catalyst at 500 °C.



## b. Preparation of Acetaldehyde

## (i) Laboratory Method

Acetaldehyde is prepared in the laboratory by the oxidation of ethyl alcohol with acidified sodium dichromate solution.

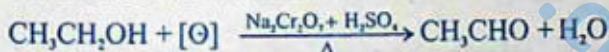

A mixture of ethyl alcohol and sodium dichromate solution is run into boiling dilute sulphuric acid. Immediately a vigorous reaction takes place and the acetaldehyde formed in liquid state is immediately distilled off. This prevents the oxidation of acetaldehyde to acetic acid. Ethyl alcohol remains in solution until it is oxidised. Pure acetaldehyde is obtained by redistillation.

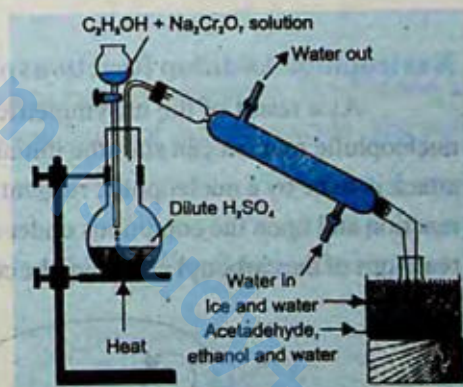
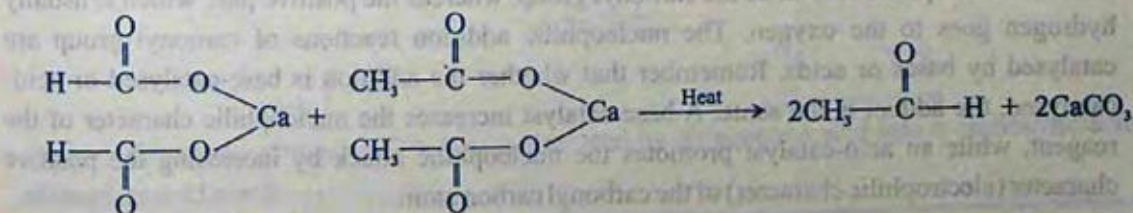

Fig. 12.2 Preparation of Acetaldehyde

Acetaldehyde can also be prepared by the dry distillation of a mixture of calcium salts of formic acid and acetic acid.



**(ii) Industrial Method**

Acetaldehyde is prepared industrially by air oxidation of ethylene using palladium chloride catalyst with a cupric chloride promoter.

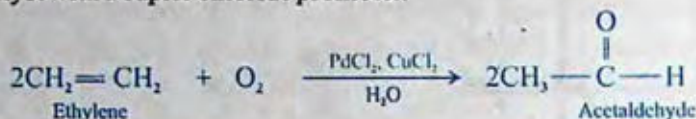
**C. Preparation of Acetone**

Acetone is prepared by dry distillation of calcium acetate.

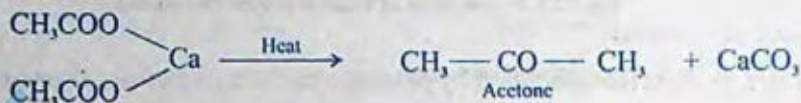
**12.4 REACTIVITY OF CARBONYL GROUP**

The carbonyl group has a  $\sigma$ -bond and a  $\pi$ -bond. Thus it can undergo addition reactions. Most reagents react with the carbonyl group by adding to it. As oxygen is more electronegative, it tends to attract the  $\pi$  electrons to itself. This attraction makes the carbonyl group a polar group. The oxygen atom has a partial negative charge on it and is nucleophilic, whereas the carbon atom has a partial positive charge and is electrophilic,

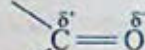
**Nucleophilic Addition Reactions of Aldehydes and Ketones**

As a result of the unsymmetrical electronic distribution about the carbonyl group, the nucleophilic reagent can start the initial attack on the carbon. It appears that whether the initial attack is to be by a nucleophilic reagent or by an electrophilic reagent depends upon a particular reaction and upon the conditions under which that reaction is carried out. Therefore, most of the reactions of the carbonyl group will be considered to be nucleophilic addition reactions.



In these reactions of aldehydes and ketones, the negative part of the reagent combines with the electrophilic carbon of the carbonyl group, whereas the positive part, which is usually hydrogen goes to the oxygen. The nucleophilic addition reactions of carbonyl group are catalysed by bases or acids. Remember that whether the addition is base-catalysed or acid-catalysed, the adduct is the same. A base catalyst increases the nucleophilic character of the reagent, while an acid-catalyst promotes the nucleophilic attack by increasing the positive character (electrophilic character) of the carbonyl carbon atom.

## 12.5 REACTIONS OF CARBONYL COMPOUNDS

### 12.5.1 Nucleophilic Addition Reactions

The characteristic reactions of carbonyl compounds are nucleophilic addition reactions.

#### (a) Base-Catalysed Addition Reactions

A base-catalysed nucleophilic addition reaction will take place with a strong nucleophilic reagent. The base reacts with the reagent and generates the nucleophile. The addition is initiated by the attack of a nucleophile on the electrophilic carbon of the carbonyl group. The general mechanism of the reaction is as follows:

#### General mechanism

The base-catalysed nucleophilic addition reactions of aldehydes and ketones are the following:

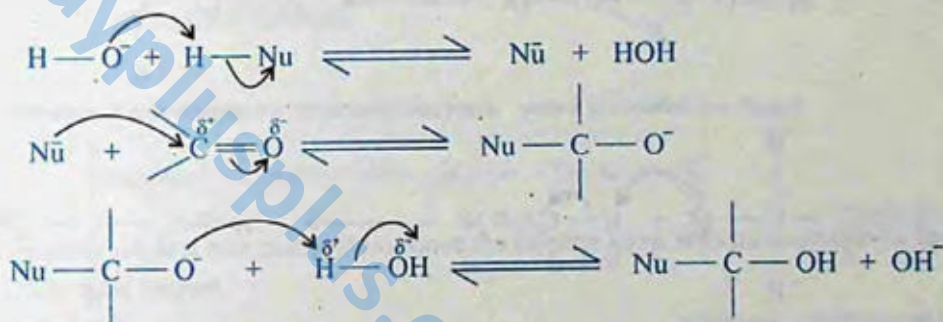

#### 1. Addition of Hydrogen Cyanide

Hydrogen cyanide adds to aldehydes and ketones to form cyanohydrins. The reaction is carried out by adding slowly a mineral acid to an aqueous solution of sodium cyanide. The acid generates HCN from sodium cyanide *in situ*.

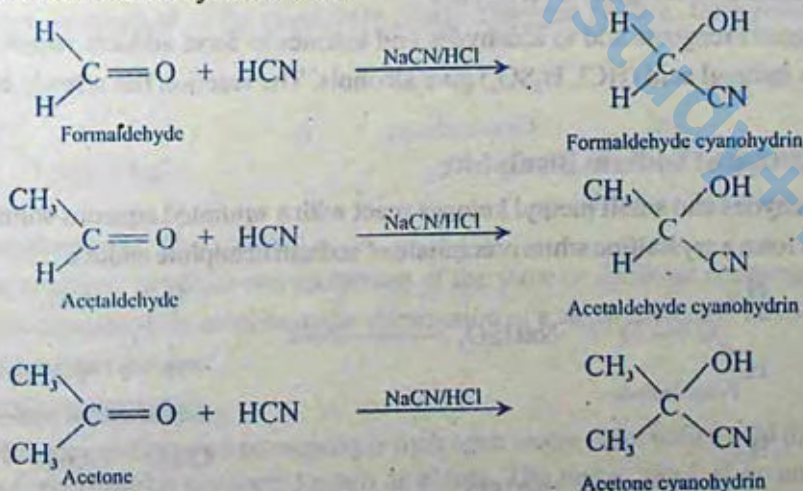

The cyano group,  $-\text{C} \equiv \text{N}$  is hydrolysed by an aqueous acid into a carboxylic acid through an acid amide.

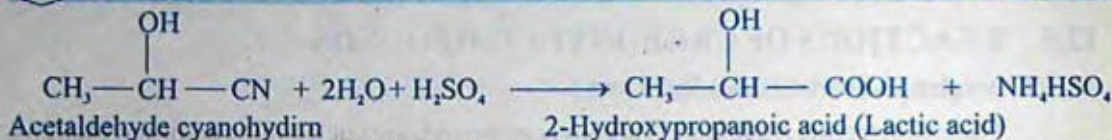

The reaction is used in the synthesis of  $\alpha$ -hydroxy acids that contain one carbon atom more than the number of carbon atoms in the starting aldehydes or ketones.

### Mechanism:

Hydrogen cyanide itself is not very nucleophilic and does not ionize to form cyanide ions to a significant extent. Thus, a source of cyanide ion such as NaCN or KCN is used. The mechanism of the reaction is as follows:

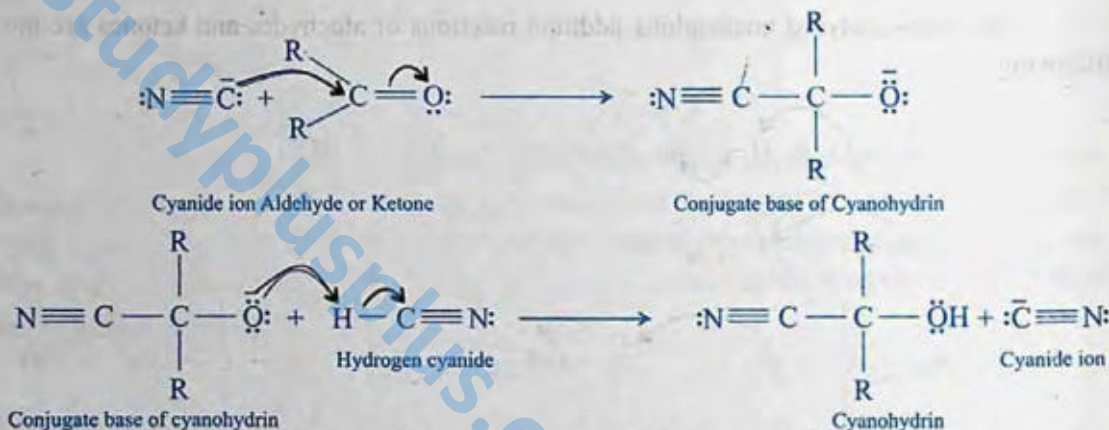

The hydroxide ion liberated in the formation of cyanohydrin reacts with undissociated hydrogen cyanide and produces more cyanide ions, which in turn react with more carbonyl compound.

## 2. Addition of Grignard Reagents

Grignard reagents add to aldehydes and ketones to form adducts which on hydrolysis with a dilute mineral acid ( $\text{HCl}$ ,  $\text{H}_2\text{SO}_4$ ) give alcohols. The reaction has already been studied in chapter 10.

## 3. Addition of Sodium Bisulphite

Aldehydes and small methyl ketones react with a saturated aqueous solution of sodium bisulphite to form a crystalline white precipitate of sodium bisulphite adduct.

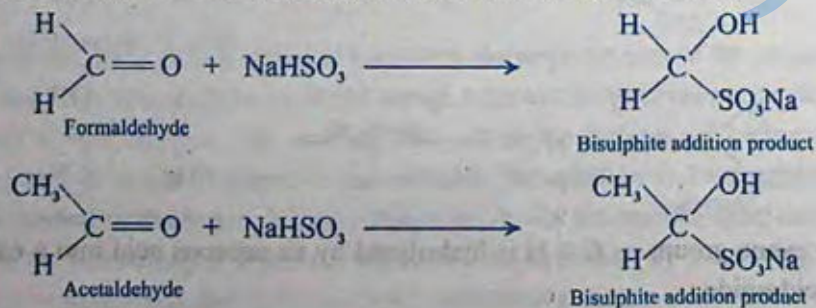

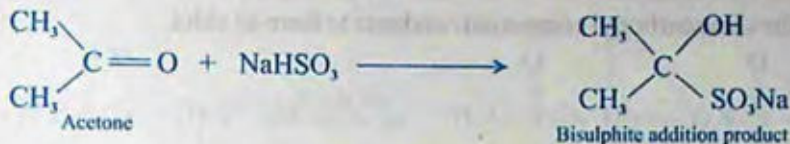

Bisulphite on heating with a dilute mineral acid (HCl or H<sub>2</sub>SO<sub>4</sub>), regenerates the parent aldehyde or ketone.

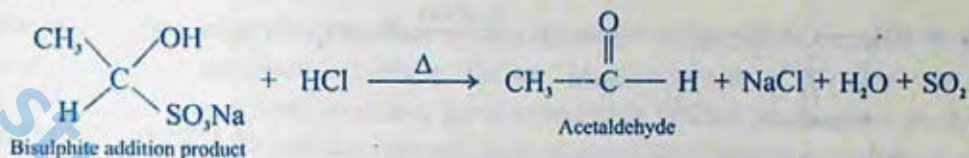

The reaction is used for the separation and purification of carbonyl compounds from non-carbonyl compounds such as alcohols.

### Mechanism:

Sodium bisulphite ionises to form sulphite ions.



The sulphite ion acts as a nucleophile, since the sulphur atom is more nucleophilic than oxygen, a C—S bond is formed.

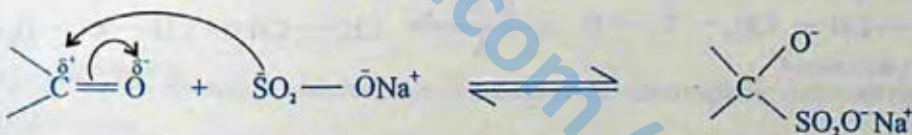

Proton is attached to the negatively charged oxygen atom to form bisulphite addition product.

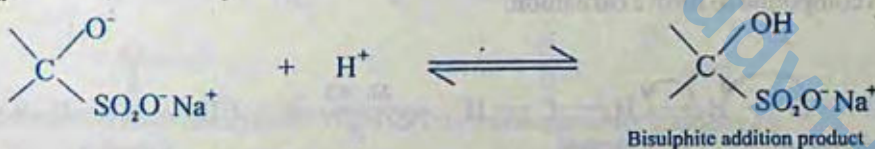

## 4. Condensation Reactions

The reactions in which two molecules of the same or different compounds combine to form a new compound with or without the elimination of a small molecule like H<sub>2</sub>O or NH<sub>3</sub>, are called condensation reactions.

### (i) Aldol Condensation

Aldehydes and ketones possessing  $\alpha$ -hydrogen atoms react with a cold dilute solution of an alkali to form addition products known as aldols. The name 'aldol' is given to the product because it contains both aldehyde and alcohol functional groups. Note that the name aldol condensation is reserved for the reaction that starts with two identical carbonyl compounds. Two

molecules of the same carbonyl compound condense to form an aldol.

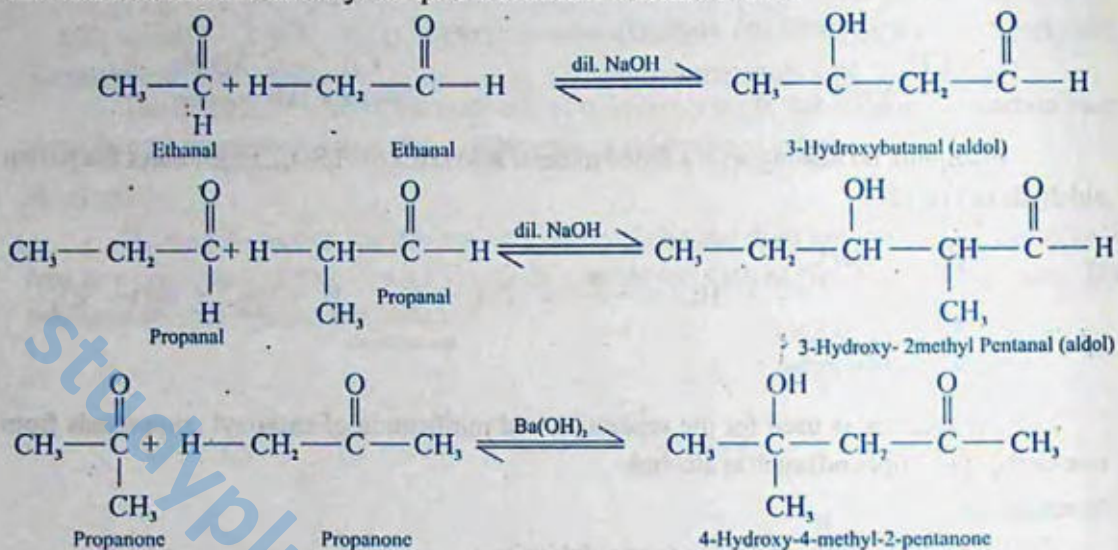

The aldol compound readily loses water on heating in the presence of dilute acid to form an unsaturated carbonyl compound. A carbon-carbon double bond is formed between the  $\alpha$ - and  $\beta$ -carbon atoms.

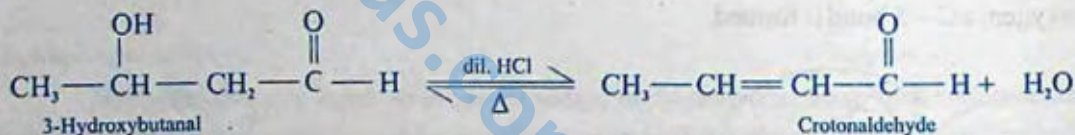

### Mechanism of Aldol Condensation

The hydroxide ion acts as a base. It removes a proton from  $\alpha$ -carbon of one molecule of the carbonyl compound to form a carbanion.

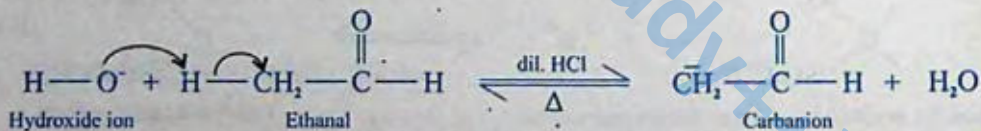

The carbanion acts as a nucleophile. It attacks the electrophilic carbonyl carbon atom of the unchanged second molecule to form an alkoxide ion.

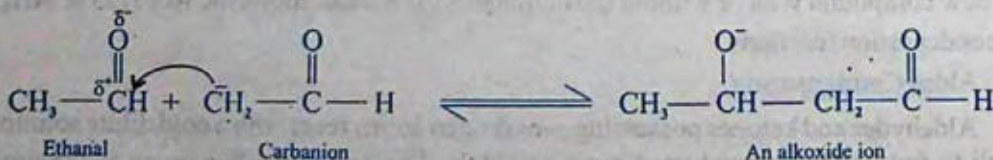

The alkoxide ion removes a proton from water to form aldol.

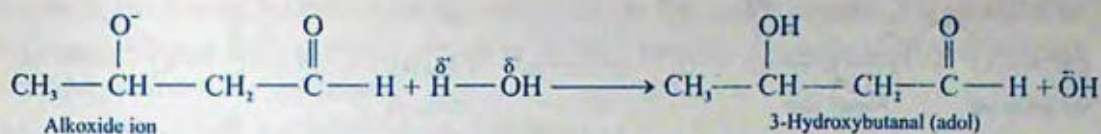

The basic catalyst hydroxide ion is regenerated.

### 5. Cannizzaro's Reaction

Aldehydes that have no  $\alpha$ -hydrogen atoms undergo Cannizzaro's reaction. It is a disproportionation (self oxidation-reduction) reaction. Two molecules of the aldehyde are involved, one molecule being converted into the corresponding alcohol (the reduced product) and the other into the acid in the salt form (the oxidation product). The reaction is carried out with 50 percent aqueous solution of sodium hydroxide at room temperature.

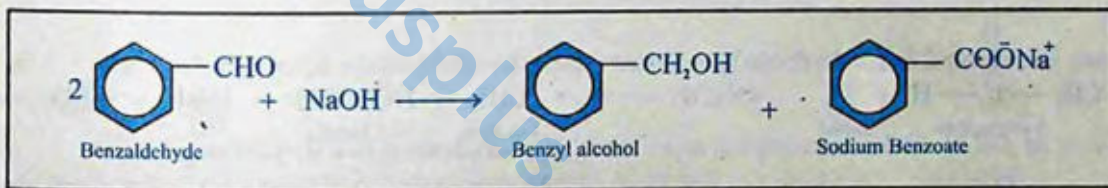

### Mechanism

The hydroxide ion acts as a nucleophile. It attacks on the electrophilic carbonyl carbon to form a complex anion.

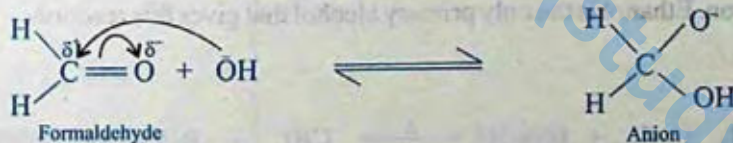

The anion transfers a hydride ion to second molecule of formaldehyde.

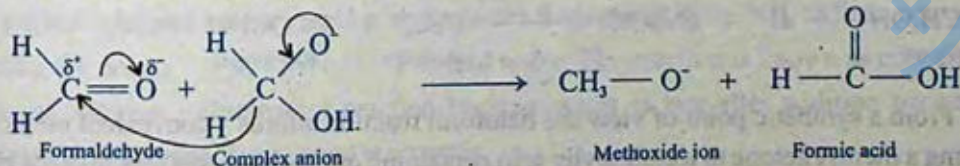

The presence of the negative charge on oxygen of the anion helps in the loss of hydride ion.

The methoxide ion acts as a base and abstracts a proton from formic acid to form methanol and formate ion.



Iodoform test is used for distinguishing methyl ketones from other ketones. It is also used to distinguish ethanol from methanol and other primary alcohols. It can be used to distinguish acetaldehyde from other aldehydes.

### (b) Acid-Catalysed Addition Reactions

The acid catalysed nucleophilic addition reaction will take place with a weak nucleophilic reagent. The addition is initiated by the proton ( $H^+$ ) liberated by the acid. The proton combines with the carbonyl oxygen atom and increases the electrophilic character of the carbonyl carbon. As a result, the attack of the weaker nucleophile on the electrophilic carbon becomes easier.

The general mechanism of the reaction is as follows:

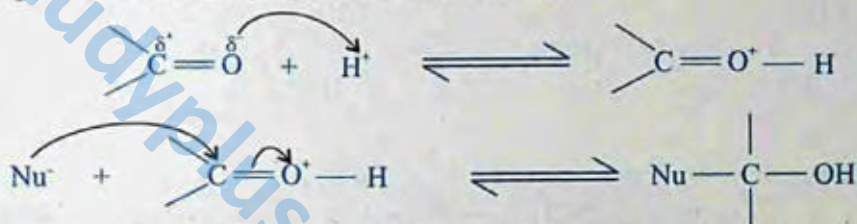

The acid-catalysed nucleophilic addition reactions of aldehydes and ketones are the following.

- Both formaldehyde and acetaldehyde polymerize in the presence of dil.  $H_2SO_4$  to give metaformaldehyde and paraldehyde respectively.

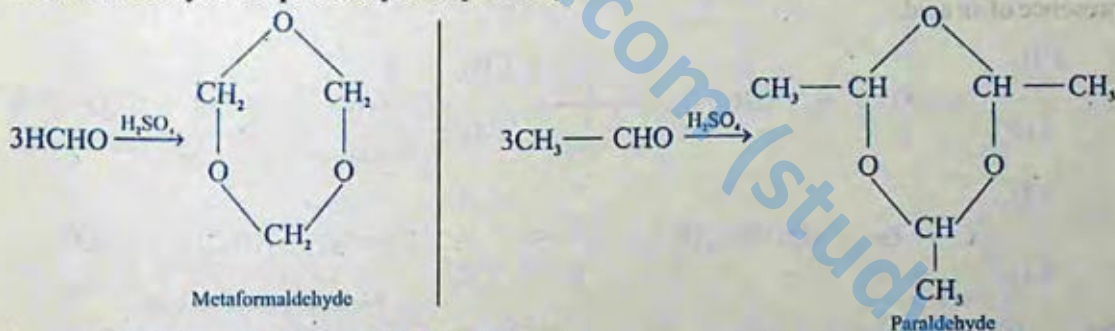

### 2. Reactions of Ammonia Derivatives

Aldehydes and ketones react with ammonia derivatives,  $G-NH_2$  to form compounds containing the group,  $\text{>C=N-G}$  and water. The reaction is known as condensation reaction or addition-elimination reaction because water is lost after addition occurs. The reaction is acid catalysed. The general reaction is:

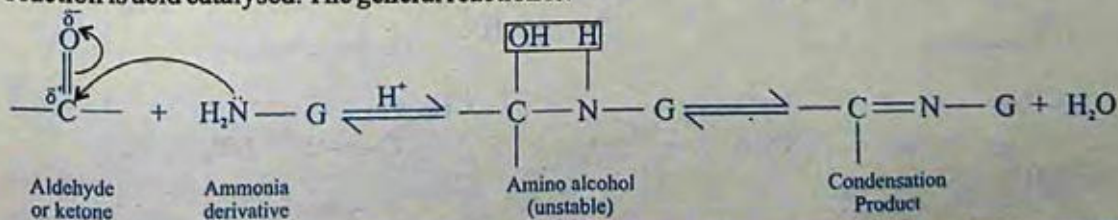

Where  $G = \ddot{O}H, -\ddot{N}H_2, -\ddot{N}HC_6H_5, -\ddot{N}HCONH_2$ , etc.

Some commonly used ammonia derivatives are hydroxylamine,  $NH_2OH$ , hydrazine,  $NH_2NH_2$ , phenylhydrazine,  $C_6H_5NHNH_2$ , semicarbazide,  $NH_2NHCONH_2$ , and 2,4-dinitrophenylhydrazine,  $NH_2NHC_6H_3(NO_2)_2$ .

The reactions of the above stated ammonia derivatives with aldehydes and ketones are as follow.

(i) **Reaction with Hydroxylamine**

Aldehydes and ketones react with hydroxy lamine to form oximes in the presence of an acid.

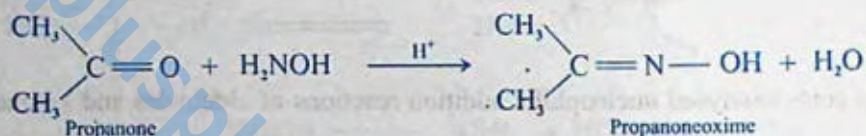
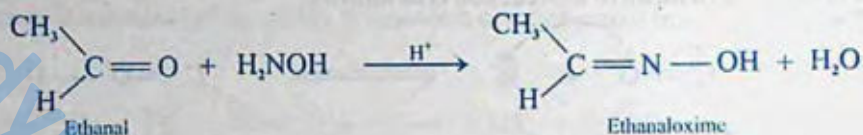

(ii) **Reaction with Phenylhydrazine**

Aldehydes and ketones react with phenylhydrazine to form phenylhydrazones in the presence of an acid.

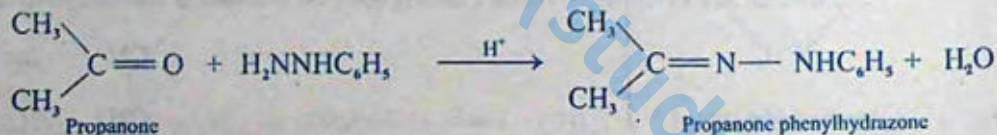

(iii) **Reaction with Hydrazine**

Aldehydes and ketones react with hydrazine to form hydrazones in the presence of an acid.

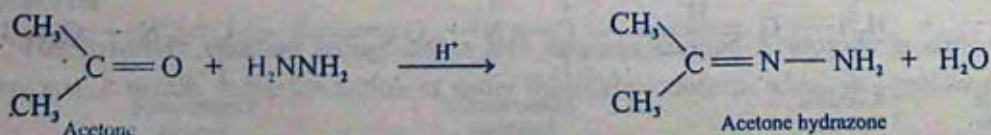
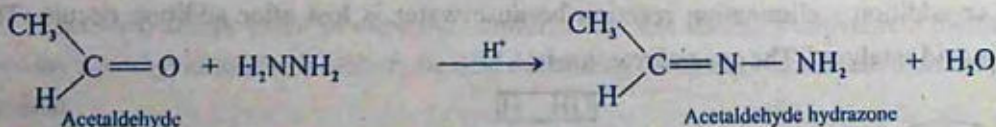

## (iv) Reaction with 2, 4-Dinitrophenylhydrazine [ 2,4-DNPH ]

Aldehydes and ketones react with 2, 4-dinitrophenylhydrazine to form 2, 4-dinitrophenylhydrazones in the presence of an acid.

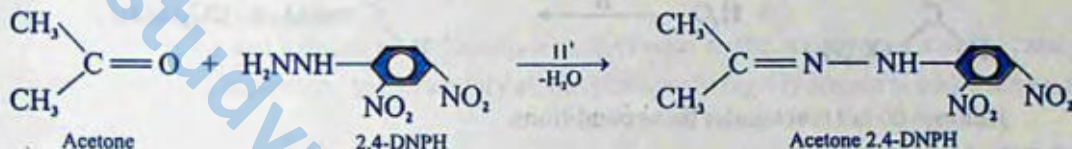
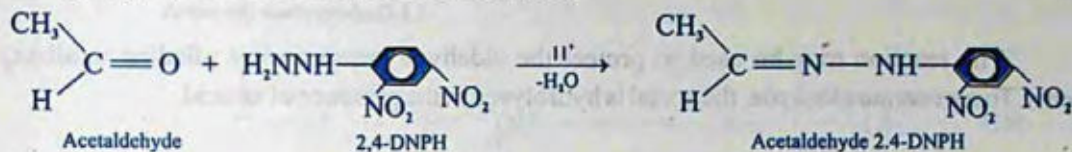

The reaction can be used for the identification of aldehydes and ketones because 2, 4-dinitrophenylhydrazones are usually yellow or orange crystalline solids.

**Mechanism of the Reactions of Ammonia Derivatives**

Step (i) Protonation of oxygen of the carbonyl group.



Step (ii) Nucleophilic attack of nitrogen of ammonia derivative on the electrophilic positively charged carbon and deprotonation of the adduct.

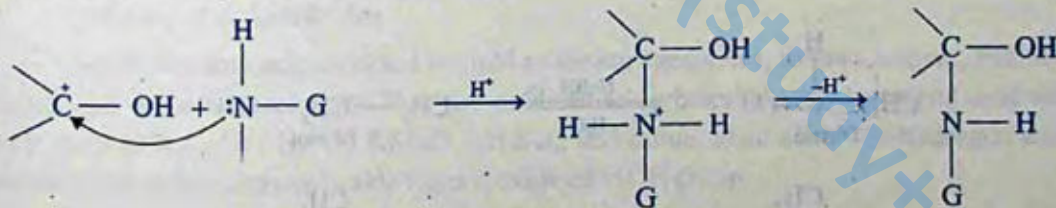

Step (iii) Protonation of oxygen of hydroxyl group followed by the removal of water.

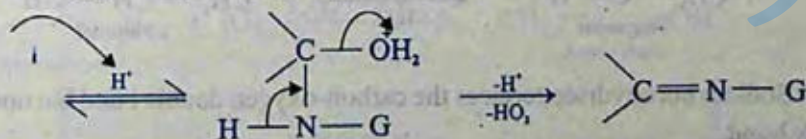
**9. Acetals of Alcohols**

Aldehydes combine with alcohols in the presence of hydrogen chloride gas to form acetals. The hydrogen chloride gas acts as a catalyst. Both the alcohol and the hydrogen chloride gas must be dry.

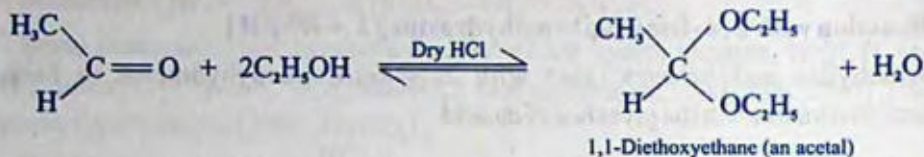

The reaction may be used to protect the aldehyde group against alkaline oxidizing agents. To regenerate aldehyde, the acetal is hydrolysed in the presence of an acid.

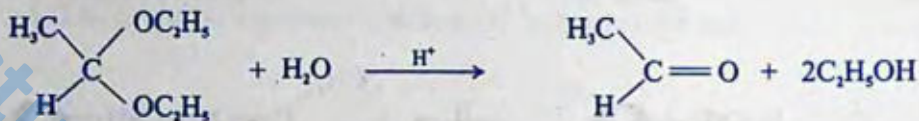

Ketones do not react under these conditions.

### 12.5.2 Reduction Reactions

Aldehydes and ketones can both be reduced. Aldehydes are reduced to primary alcohols whereas ketones to secondary alcohols. The carbonyl group is converted into an alcohol.

#### (i) Reduction with Sodium Borohydride

Aldehydes and ketones are reduced to alcohols with sodium borohydride,  $\text{NaBH}_4$ .

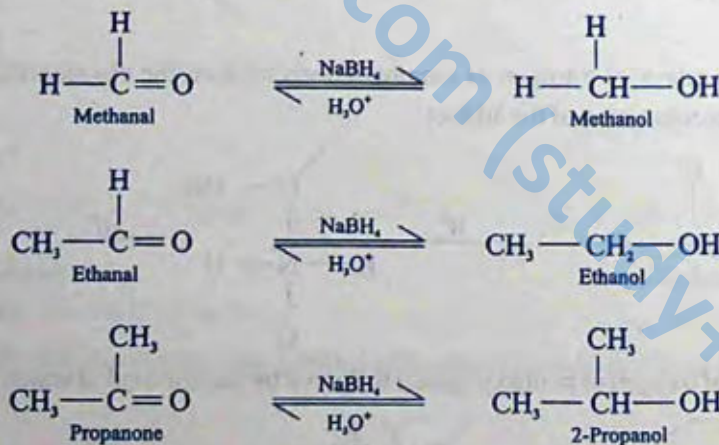

Sodium borohydride reduces the carbon-oxygen double bond but not the carbon-carbon multiple bond.

#### Mechanism:

The tetrahydridoborate (III) ion,  $\text{BH}_4^-$  is source of hydride ion,  $\text{H}^-$ . The hydride ion acts as a nucleophile. It attacks on the electrophilic carbon of the carbonyl group to give an alkoxide ion.

The alkoxide ion is protonated with water to give an alcohol.

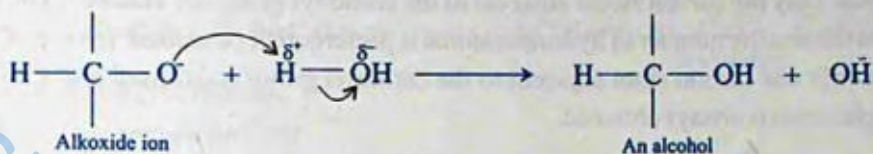
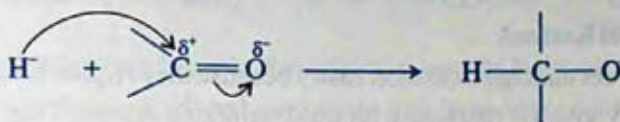
**(ii) Catalytic Reduction**

Aldehydes and ketones on reduction with hydrogen in the presence of a metal catalyst like Pd, Pt or Ni form primary and secondary alcohols respectively. Hydrogen is added across the carbonyl group.

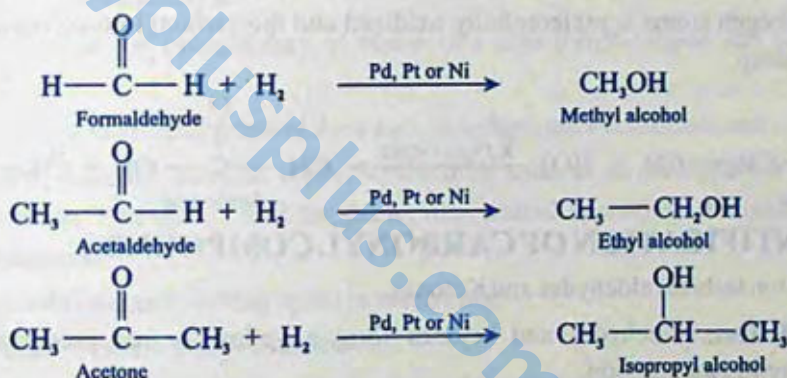
**12.5.3 Oxidation Reactions****(I) Oxidation of Aldehydes**

Aldehydes are easily oxidised by mild oxidising agents like Tollen's reagent, Fehling's solution and Benedict's solution. They are oxidised to carboxylic acids by strong oxidising agents such as  $\text{K}_2\text{Cr}_2\text{O}_7 / \text{H}_2\text{SO}_4$ ,  $\text{KMnO}_4 / \text{H}_2\text{SO}_4$ , and dilute nitric acid. The hydrogen atom attached to the carbonyl group in aldehydes is oxidised to OH group.

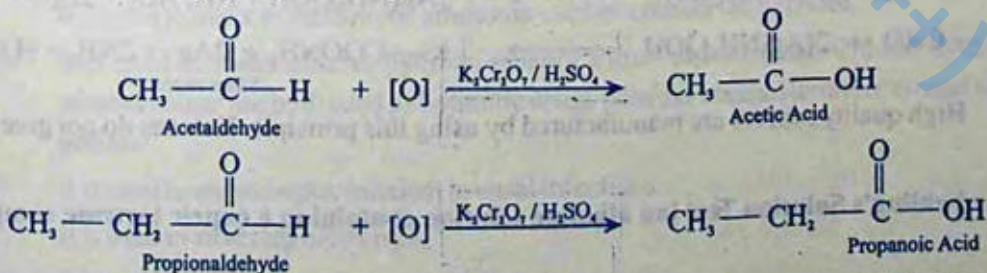

The carboxylic acid has the same number of carbon atoms as are present in the parent aldehyde.

**(ii) Oxidation of Ketones**

Ketones do not undergo oxidation easily because they require breaking of strong carbon-carbon bond. They give no reaction with mild oxidizing agents. They are only oxidised by strong oxidising agents such as  $K_2Cr_2O_7/H_2SO_4$ ,  $KMnO_4/H_2SO_4$ , and conc.  $HNO_3$ . In oxidation of ketones, only the carbon atoms adjacent to the carbonyl group are attacked. The carbon atom joined to the smaller number of hydrogen atoms is preferentially oxidised. In case of symmetrical ketones only one carbon atom adjacent to the carbonyl group is oxidised and a mixture of two carboxylic acids is always obtained.

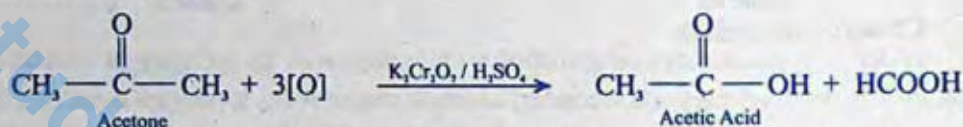

However, in case of unsymmetrical ketones, the carbon atom joined to the smaller number of hydrogen atoms is preferentially oxidized and the carbonyl group remains with the smaller alkyl group.

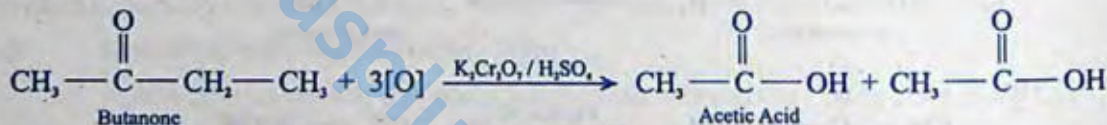
**12.6 IDENTIFICATION OF CARBONYL COMPOUNDS**

Detection tests for aldehydes and Ketones.

**1.2,4 DNPH Test:** Aldehydes and ketones form a yellow or red precipitate with 2,4 dinitrophenyl hydrazine solution.

**2. Sodium Bisulphite Test:** Aldehydes and small methyl ketones form a crystalline white precipitate with saturated sodium bisulphite solution.

**3. Tollen's Test [Silver Mirror Test]:** Aldehydes form silver mirror with Tollen's reagent (ammoniacal silver nitrate solution). Add Tollen's reagent to an aldehyde solution in a test tube and warm. A silver mirror is formed on the inside of the test tube.

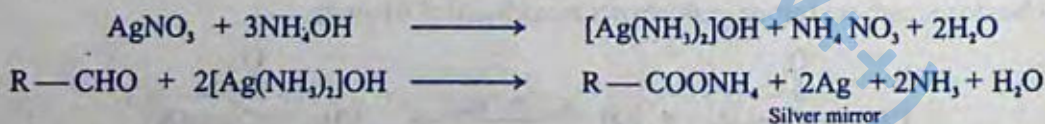

High quality mirrors are manufactured by using this principle. Ketones do not give this test.

**4. Fehling's Solution Test [an alkaline solution containing a cupric tartrate complex ion]:**

Aliphatic aldehydes form a brick-red precipitate with Fehling's solution. To an aldehyde solution, add Fehling's solution and boil. A brick red precipitate of cuprous oxide is formed. Ketones do not give this test.

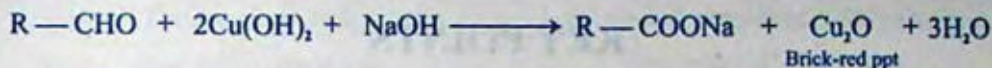

5. **Benedict's Solution Test [an alkaline solution containing a cupric citrate complex ion]:** Aliphatic aldehydes form a brick-red precipitate with Benedict's solution. To an aldehyde solution, add Benedict's solution and boil. A brick-red precipitate of cuprous oxide is formed.



Ketones do not give this test.

6. **Sodium Nitroprusside Test:**

Ketones produce a wine red or orange red colour on adding alkaline sodium nitroprusside solution dropwise. Aldehydes do not give this test.

## 12.7 USES

### (a) Uses of Formaldehyde

- (i) It is used in the manufacture of resins like urea-formaldehyde and plastics such as bakelite.
- (ii) It is used in the manufacture of dyes such as indigo, para-rosaniline, etc.
- (iii) Its 40% aqueous solution called formalin is used as an antiseptic, a disinfectant, a germicide, a fungicide and for preserving animal specimens and sterilising surgical instruments.
- (iv) It is used as a decolourising agent in vat dyeing.
- (v) It is used in the silvering of mirrors.
- (vi) It is used in making medicine urotropine used as a urinary antiseptic.
- (vii) It is used in making formamint (formaldehyde + lactose) used as throat lozenges.
- (viii) It is used in the processing of anti-polio vaccine.

### (b) Uses of Acetaldehyde

- (i) It is used in the production of acetic acid, acetic anhydride, n-butanol, ethanol, 2-ethyl-1-hexanol, vinyl acetate, paraldehyde, ethylacetate, etc.
- (ii) It is used to make acetaldehyde ammonia used as a rubber-accelerator.
- (iii) It is used to make chloral hydrate, ethanol trimer and tetramer. Chloral hydrate and ethanol trimer are both used as hypnotic drugs whereas ethanol tetramer is used as a slug poison.
- (iv) It is used as an antiseptic inhalent in nasal infections.
- (v) It is used in silvering of mirrors.
- (vi) It is used to make phenolic resins and synthetic drugs.

## KEY POINTS

1. Aldehydes and ketones contain the carbonyl group,  $C=O$  as the functional group.
2. Both aldehydes and ketones can be prepared by the oxidation of primary and secondary alcohols respectively.
3. Both aldehydes and ketones undergo nucleophilic addition reactions. In these reactions, the negative part of the reagent combines with the electrophilic carbon of the carbonyl group whereas the positive part goes to the oxygen atom. They are base catalyzed addition reactions.
4. Two molecules of the same carbonyl compound condense to form an aldol. Aldehydes and ketones containing  $\alpha$ -hydrogen atoms undergo this reaction in the presence of dilute sodium hydroxide.
5. Aldehydes that have no  $\alpha$ -hydrogen atoms undergo Cannizzaro's reaction in the presence of concentrated sodium hydroxide.
6. Acetaldehyde and only methyl ketones react with halogens in the presence of sodium hydroxide to give haloform. It provides a useful method for converting a methyl ketone to a carboxylic acid containing one carbon atom less than the parent methyl ketone. Iodoform test is used for distinguishing methyl ketones from other ketones.
7. Aldehydes and ketones react with ammonia derivatives,  $G-NH_2$  to form condensation products containing the group,  $C=N-G$  and water. The reaction is acid-catalysed.
8. Aldehydes and ketones are reduced to alcohols with sodium borohydride. Aldehydes and ketones are also reduced to alcohols with molecular hydrogen in the presence of catalyst like Pd, Pt or Ni.
9. Aldehydes are oxidized to carboxylic acids.  $K_2Cr_2O_7$  in  $H_2SO_4$  or  $KMnO_4$  in  $H_2SO_4$  may be used as the oxidising agent. Ketones resist oxidation.
10. Aldehydes form silver mirror with Tollen's reagent. Ketones do not give this test.
11. Aldehydes give a brick red precipitate with Fehling's solution on boiling.

## EXERCISE

### Q.1 Fill in the blanks.

- i) Aldehydes are the first oxidation product of \_\_\_\_\_.
- ii) Ketones are the first oxidation product of \_\_\_\_\_.
- iii) Aldehydes and ketones undergo \_\_\_\_\_ addition reactions.
- iv) Formaldehyde reacts with \_\_\_\_\_ to give primary alcohol.
- v) Acetaldehyde reacts with \_\_\_\_\_ to give 2-butanol.
- vi) Aldehydes are strong \_\_\_\_\_ agents.
- vii) The oxidation of an \_\_\_\_\_ always gives a carboxylic acid.

- viii) The reduction of a \_\_\_\_\_ always gives a secondary alcohol.  
ix) Formaldehyde gives \_\_\_\_\_ test with Tollen's reagent.  
x) Acetaldehyde gives a \_\_\_\_\_ precipitate with Fehling's solution.

**Q.2 Indicate True or False.**

- i) Formaldehyde is used in the silvering of mirrors.  
ii) Ketones combine with alcohols in the presence of HCl gas to form acetals.  
iii) Acetaldehyde undergoes Cannizzaro's reaction.  
iv) Aldol condensation reaction is given by only those aldehydes and ketones which contain an  $\alpha$ -hydrogen atom.  
v) Cannizzaro's reaction is given by only those aldehydes containing no  $\alpha$ -hydrogen atom.  
vi) Propanal and propanone behave differently with Tollen's reagent.  
vii) Acetone reacts with sodium bisulphite to give a yellow crystalline product.  
viii) Acetone on reduction gives a primary alcohol.  
ix) 40% aqueous solution of formaldehyde is called formalin.

**Q.3 Multiple choice questions. Encircle the correct answer.**

- i) The carbon atom of a carbonyl group is:  
(a)  $sp$  hybridized (b)  $sp^2$  hybridized  
(c)  $sp^3$  hybridized (d) none of these
- ii) Formalin is:  
(a) 10% solution of formaldehyde in water  
(b) 20% solution of formaldehyde in water  
(c) 40% solution of formaldehyde in water  
(d) 60% solution of formaldehyde in water
- iii) Which of the following will have the highest boiling point?  
(a) Methanal (b) Ethanal  
(c) Propanal (d) 2-Hexanone
- iv) Ketones are prepared by the oxidation of:  
(a) primary alcohol (b) secondary alcohol  
(c) tertiary alcohol (d) all of these
- v) Acetone reacts with HCN to form a cyanohydrin. It is an example of:  
(a) electrophilic addition (b) electrophilic substitution  
(c) nucleophilic addition (d) nucleophilic substitution
- vi) Which of the following compounds will not give iodoform test on treatment

with  $I_2/NaOH$ :

- (a) acetaldehyde (b) acetone  
(c) butanone (d) 3-Pentanone

vii) Which of the following compounds will react with Tollen's reagent?

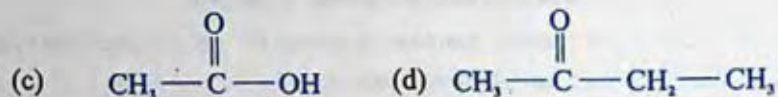

viii) Cannizzaro's reaction is not given by:

- (a) Formaldehyde (b) Acetaldehyde  
(c) Benzaldehyde (d) Trimethylacetaldehyde

ix) Which of the following reagents will react with both aldehydes and ketones?

- (a) Grignard reagent (b) Tollen's reagent  
(c) Fehling's reagent (d) Benedict's reagent

Q. 4 Give one laboratory and one industrial method for the preparation of formaldehyde.

Q. 5 How does formaldehyde react with the following reagents?

- (i)  $CH_3MgI$  (ii)  $HCN$  (iii)  $NaHSO_3$  (iv) conc.  $NaOH$   
(v)  $NaBH_4/H_2O$  (vi) Tollen's reagent (vii) Fehling's reagent

Q. 6 Give one laboratory and one industrial method for the preparation of acetaldehyde.

Q. 7 How does acetaldehyde react with the following reagents?

- (i)  $C_2H_5MgI$  (ii)  $HCN$  (iii)  $NaHSO_3$  (iv) dilute  $NaOH$   
(v)  $I_2/NaOH$  (vi)  $NaBH_4/H_2O$  (vii)  $NH_2OH$  (viii)  $K_2Cr_2O_7/H_2SO_4$

Q. 8 Describe briefly the mechanism of nucleophilic addition to a carbonyl compound.

Q. 9 Explain with mechanism the addition of ethylmagnesium bromide to acetaldehyde. What is the importance of this reaction?

Q. 10 Explain with mechanism the addition of sodium bisulphite to acetone. What is the utility of this reaction?

Q. 11 Describe with mechanism aldol condensation reaction. Why formaldehyde does not give this reaction?

Q. 12 What types of aldehydes give Cannizzaro's reaction? Give its mechanism.

Q. 13 Explain the mechanism of the reaction of phenylhydrazine with acetone.

Q. 14 Using ethyne as a starting material how would you get acetaldehyde, acetone and ethyl alcohol?

- Q. 15 Give the mechanism of addition of HCN to acetone.
- Q. 16 How would you bring about the following conversions?
- |                                  |                                   |
|----------------------------------|-----------------------------------|
| (i) Acetone into t-butyl alcohol | (ii) Propanal into 1-propanol     |
| (iii) Propanone into 2-propanol  | (iv) Methanal into ethanal        |
| (v) Ethanal into propanone       | (vi) Ethanal into 2-propanol      |
| (vii) Ethyne into ethanal        | (viii) Ethene into ethanal        |
| (ix) Ethanal into ethanol        | (x) Ethanol into 2-butanone       |
| (xi) Methanol into ethanal       | (xii) Ethanol into ethanoic acid. |
- Q. 17 How will you distinguish between:
- |                                   |                                    |
|-----------------------------------|------------------------------------|
| (i) Methanal and ethanal          | (ii) Ethanal and propanone         |
| (iii) Ethanal and propanal        | (iv) Acetone and ethyl alcohol     |
| (v) Butanone and 3-pentanone      | (vi) Acetaldehyde and benzaldehyde |
| (vii) 2-Pentanone and 3-pentanone |                                    |
- Q. 18 Discuss oxidation of (a) aldehydes (b) ketones with:
- |                          |                       |                          |
|--------------------------|-----------------------|--------------------------|
| (i) $K_2Cr_2O_7/H_2SO_4$ | (ii) Tollen's reagent | (iii) Fehling's solution |
|--------------------------|-----------------------|--------------------------|
- Q. 19 Discuss reduction of: (a) aldehydes (b) ketones with
- |                   |               |
|-------------------|---------------|
| (i) $NaBH_4/H_2O$ | (ii) $H_2/Pd$ |
|-------------------|---------------|
- Q. 20 Give three uses for each of formaldehyde and acetaldehyde.

## CHAPTER

## 13

## CARBOXYLIC ACID

## In this chapter you will learn

1. How to name carboxylic acids and their derivatives.
2. The commercial method for the preparation of acetic acid.
3. The relationship between the structure of carboxyl group and its reactivity.
4. The effect of hydrogen bonding on the physical properties of carboxylic acids.
5. The ways of preparing four derivatives of carboxylic acids and the conversion of these derivatives back to carboxylic acids.
6. About amino acids and their significance.

## 13.1 INTRODUCTION

Organic compounds containing  $\left(\begin{array}{c} \text{O} \\ \parallel \\ -\text{C}-\text{OH} \end{array}\right)$  as a functional group are called carboxylic acids. The  $\left(\begin{array}{c} \text{O} \\ \parallel \\ -\text{C}-\text{OH} \end{array}\right)$  group which itself is made up of a carbonyl group ( $>\text{C}=\text{O}$ ) and a hydroxyl group ( $-\text{OH}$ ) is called a carboxyl group (Carb from carbonyl and oxyl from hydroxyl).

Carboxylic acid may be an aliphatic or an aromatic depending upon whether  $\left(\begin{array}{c} \text{O} \\ \parallel \\ -\text{C}-\text{OH} \end{array}\right)$  is attached to an alkyl group (or a hydrogen atom) or an aryl group. Their general formulae are:

## Aliphatic carboxylic acids

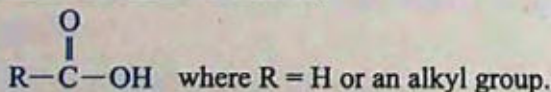

## Aromatic carboxylic acids

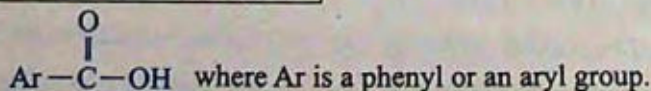

Carboxylic acids are further classified as mono, di, tri or poly carboxylic acids as they contain one, two, three or many carboxyl groups respectively in their molecules.

## Aliphatic monocarboxylic acids

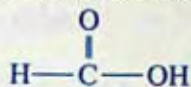

Methanoic acid or Formic acid

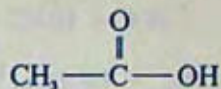

Ethanoic acid or acetic acid

## Aliphatic dicarboxylic acids

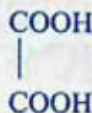

Ethanedioic acid (Oxalic acid)

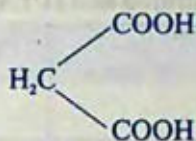

Propanedioic acid (Malonic acid)

## Aromatic monocarboxylic acids

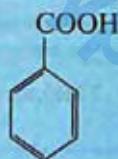

Benzoic acid

## Aromatic dicarboxylic acids

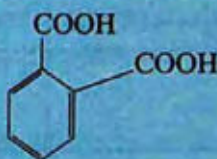

1,2-Benzenedicarboxylic acid or Phthalic acid

In this chapter we will discuss, in some detail, the chemistry of monocarboxylic acids only.

### 13.2 NOMENCLATURE OF CARBOXYLIC ACIDS

The aliphatic monocarboxylic acids are commonly called fatty acids because higher members of this series such as palmitic acid ( $\text{C}_{15}\text{H}_{31}\text{COOH}$ ), stearic acid ( $\text{C}_{17}\text{H}_{35}\text{COOH}$ ), etc. are obtained by the hydrolysis of fats and oils.

The aliphatic monocarboxylic acids may be given common names or IUPAC names.

#### 13.2.1 Common or Trivial names

The common names of carboxylic acids were derived from the source from which they are isolated. The irritation caused by an ant bite is due to formic acid (Latin word formica, ant). It was first isolated by the distillation of red ants. Similarly acetic acid was first isolated from vinegar and butyric acid was named after butyrum means butter.

#### 13.2.2 The IUPAC Nomenclature

The IUPAC names of saturated monocarboxylic acids are alkanic acids. These are derived from the names of the alkanes containing the same number of carbon atoms as the acid. The ending “-e” of the alkane name is dropped and suffix -oic acid is added. Thus acetic acid gets the name ethanoic acid.

The position of substituents are indicated by Arabic numerals with the carboxyl group



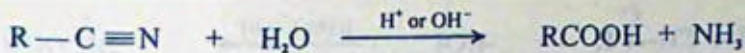

Alkanenitriles can be prepared by treating alkyl halide with alcoholic potassium cyanide.



It may be noted that acid produced has one carbon atom more than the original alkyl halide.

### 3. From Grignard Reagent

Carboxylic acids can be prepared by the reaction of Grignard reagent with carbon dioxide. This reaction is either carried out by passing carbon dioxide through the ethereal solution of corresponding Grignard reagent or by adding Grignard reagent to crushed dry ice suspended in ether. The addition product on reaction with a mineral acid produces carboxylic acid.

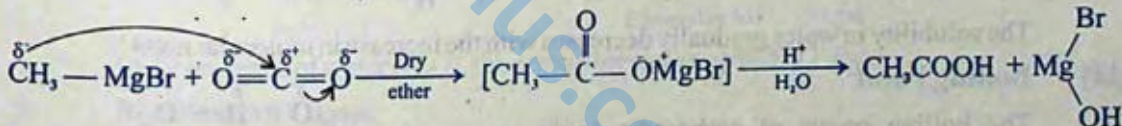
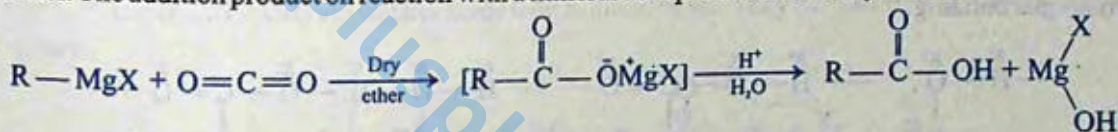

### 4. By the Hydrolysis of Esters

The appropriate ester on boiling with concentrated sodium hydroxide yields sodium salt of the acid. This resulting salt when treated with dilute HCl gives the free carboxylic acid.

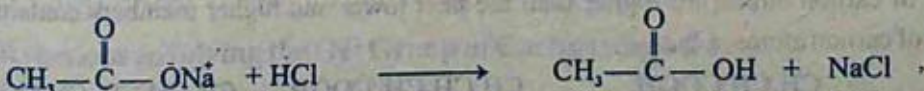
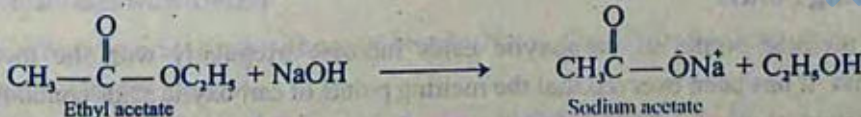
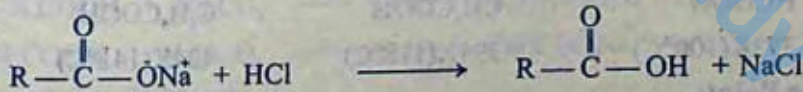
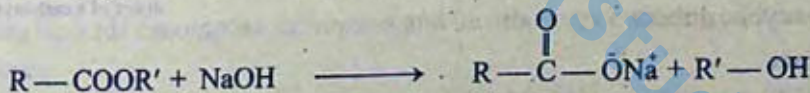

### 5. By the Oxidative Cleavage of Alkenes

Alkenes when heated with alkaline  $KMnO_4$ , are cleaved at the double bond to form carboxylic acids.

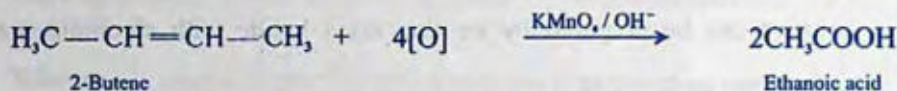
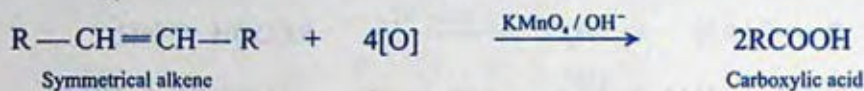

### 13.4 PHYSICAL CHARACTERISTICS

#### (i) Smell

The first three aliphatic acids, i.e., formic acid, acetic acid and propionic acid are colourless liquids and have pungent smell. The next three acids  $\text{C}_4$  to  $\text{C}_6$  are colourless liquids with somewhat unpleasant smell.

#### (ii) Solubility

Among the aliphatic acids, the first four members are very soluble in water due to hydrogen bonding.

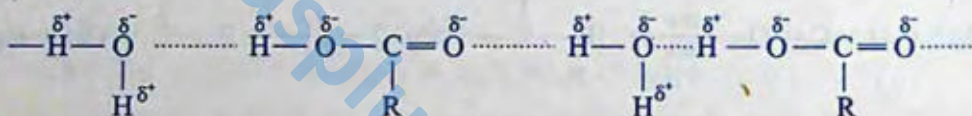

The solubility in water gradually decreases with the increase in molecular mass.

#### (iii) Boiling Point

The boiling points of carboxylic acids are relatively high due to intermolecular hydrogen bonding. The molecular mass determination in non-polar solvent like benzene shows that carboxylic acids exist as cyclic dimers.

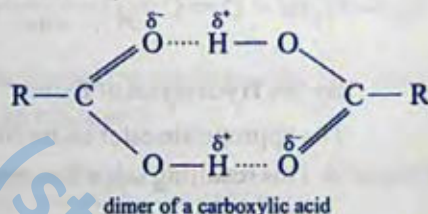

#### Boiling Points

HCOOH	$\text{CH}_3\text{COOH}$	$\text{C}_2\text{H}_5\text{COOH}$
373K(100°C)	391K(118°C)	424K(141°C)

#### (iv) Melting Points

The melting points of carboxylic acids increase irregularly with the increase in molecular mass. It has been observed that the melting points of carboxylic acids containing even number of carbon atoms are higher than the next lower and higher members containing odd number of carbon atoms, e.g.,

$\text{CH}_3\text{CH}_2\text{COOH}$ (3 carbon)	$\text{CH}_3\text{CH}_2\text{CH}_2\text{COOH}$ (4 carbon)	$\text{CH}_3\text{CH}_2\text{CH}_2\text{CH}_2\text{COOH}$ (5 carbon)
Melting Points 251 K (-22°C)	267 K (-6°C)	237 K (-36°C)

### 13.5 REACTIVITY OF CARBOXYL GROUP ( $\text{—}\overset{\text{O}}{\parallel}{\text{C}}\text{—OH}$ )

The carboxyl group displays the chemistry of both the carbonyl and the hydroxyl groups. In most reactions of carboxylic acids, the carboxyl group is retained however, the reactivity of these molecules is a consequence of the presence of the carbonyl group.

### 13.6 Reactions of Carboxylic Acids

Carboxylic acids undergo the following types of reactions.

- The reactions in which hydrogen atom of the carboxyl group is involved (salt formation).
- The reactions in which OH group is replaced by another group.
- The reactions involving carboxyl group as a whole.

#### (a) Reactions Involving H Atom of the Carboxyl Group

Carboxylic acids are weaker acids than mineral acids. They furnish  $\text{H}^+$  when dissolved in water.

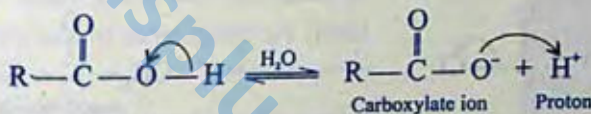

In the presence of water ( $\text{H}_2\text{O}$ ), the proton breaks away as  $\text{H}_3\text{O}^+$  ion.

#### 1. Reactions with Bases

Carboxylic acids react with bases ( $\text{NaOH}$ ,  $\text{KOH}$ ) to form salts.



#### 2. Reactions with Carbonates and Bicarbonates

Carboxylic acids decompose carbonates and bicarbonates evolving carbon dioxide gas with effervescence.



#### 3. Reactions with Metals

Carboxylic acids react with active metals ( $\text{Na}$ ,  $\text{K}$ ,  $\text{Ca}$ ,  $\text{Mg}$  etc) to form their salts with the evolution of hydrogen gas.



#### (b) Reactions Involving the OH Group of Carboxylic Acids

The carboxylic acid contains  $\text{—}\overset{\text{O}}{\parallel}{\text{C}}\text{—OH}$  functional group, and like the carbonyl group of aldehydes and ketones, is susceptible to attack by a nucleophile. The addition of a nucleophile to the carboxyl group is always followed by the displacement of the  $\text{—OH}$  group by some other

group, producing a carboxylic acid derivative. The -OH group can thus be replaced by X, OR and NH<sub>2</sub> to form halides, esters and amides, respectively.

### 1. Reaction with PCl<sub>5</sub> and SOCl<sub>2</sub>

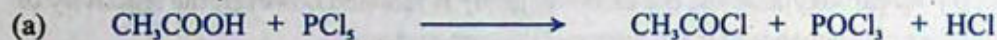

#### Mechanism

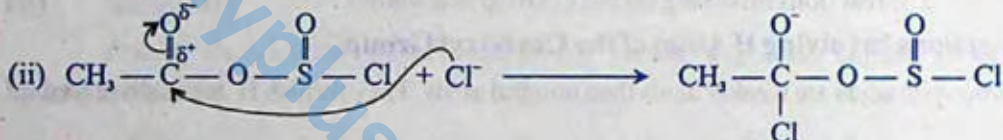

### 2. Formation of an Ester

When carboxylic acids are heated with alcohols in the presence of concentrated H<sub>2</sub>SO<sub>4</sub>, esters are formed.

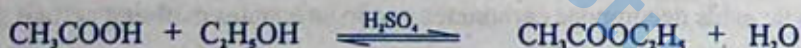

#### Mechanism

The various steps of the above reactions are as follows:

#### (i) Protonation of Carboxylic Acid



#### (ii) Attack of CH<sub>3</sub>CH<sub>2</sub>OH

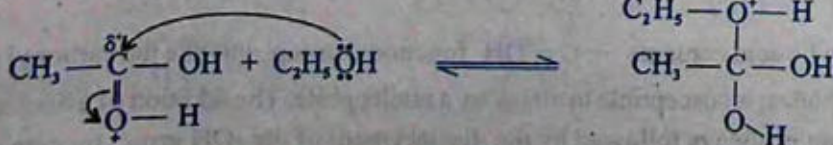

## (iii) Hydrogen Ion Transfer

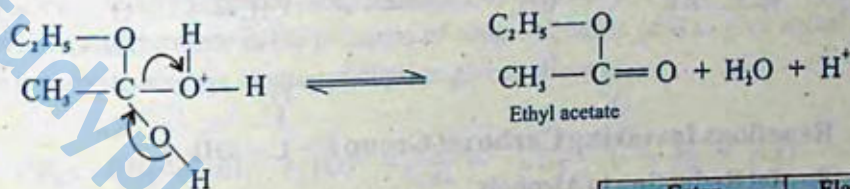
(iv) Elimination of Water and H<sup>+</sup>

Esters have fruity smell and are used as artificial flavours. Flavours of some esters are listed in the table.

## 3. Formation of Amide (Reaction with ammonia)

Carboxylic acids react with ammonia to form ammonium salts which on heating produce acid amides.

Ester	Flavour
Amylacetate	Banana
Isobutyl formate	Raspberry
Benzylacetate	Jasmine
Ethyl butyrate	pineapple
Amyl butyrate	Apricot
Otyl acetate	Orange

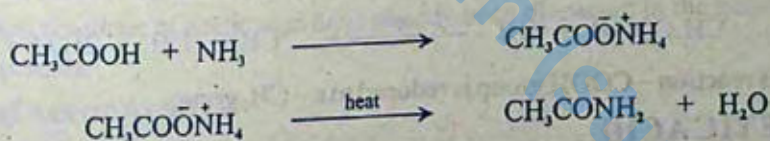

## Mechanism

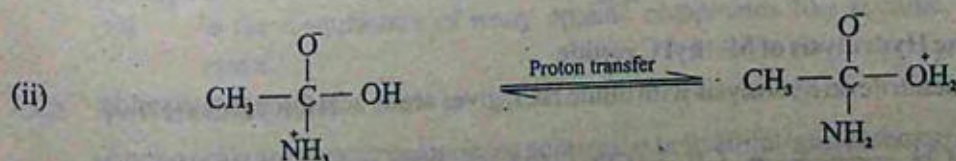
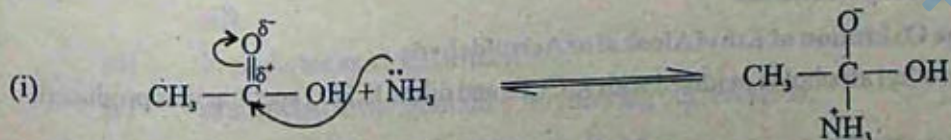

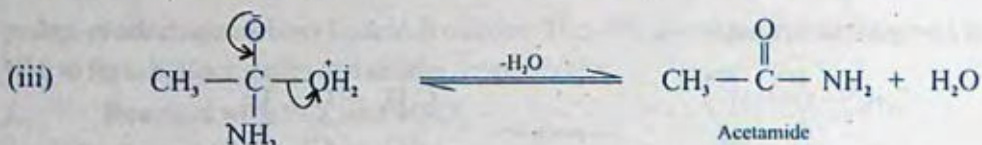

#### 4. Formation of Acid Anhydride

Carboxylic acids are dehydrated on heating strongly in the presence of phosphorus pentoxide.

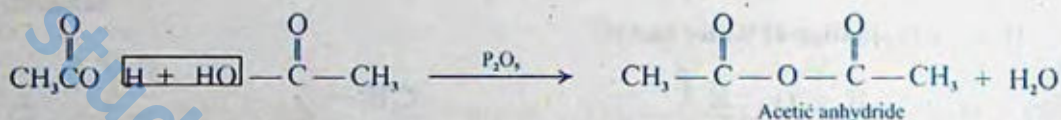

#### c) Reactions Involving Carboxyl Group ( $\begin{array}{c} \text{O} \\ \parallel \\ -\text{C}-\text{OH} \end{array}$ )

##### i) Partial Reduction to Alcohols

Carboxylic acids on reaction with lithium aluminium hydride ( $\text{LiAlH}_4$ ) are reduced to alcohols.

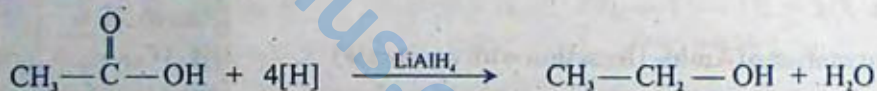

##### ii) Complete Reduction to Alkanes

Carboxylic acids on reduction with HI and red phosphorus give alkanes.



In this reaction  $-\text{COOH}$  group is reduced to a  $-\text{CH}_3$  group.

## 13.7 ACETIC ACID

It is the most important carboxylic acid. Its dilute solution is known as vinegar. Acetic acid can be prepared by any of the general methods described earlier.

### 13.7.1 Laboratory Methods

#### 1. By the Oxidation of Ethyl Alcohol or Acetaldehyde

When ethyl alcohol is oxidised with  $\text{K}_2\text{Cr}_2\text{O}_7$  and dilute  $\text{H}_2\text{SO}_4$ , acetic acid is produced.



#### 2. By the Hydrolysis of Methyl Cyanide

Ethanenitrile on hydrolysis with dilute HCl, gives acetic acid through acetamide.

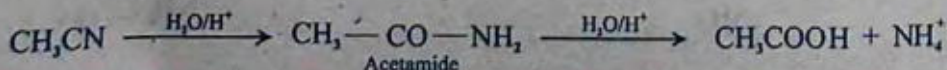

### 13.7.2 Manufacture of Acetic Acid

#### 1. From Acetylene

Acetylene is treated with 20%  $H_2SO_4$  and 1.0%  $HgSO_4$  at  $80^\circ C$  to give ethanal (acetaldehyde) which is then oxidised using  $V_2O_5$  to give acetic acid.

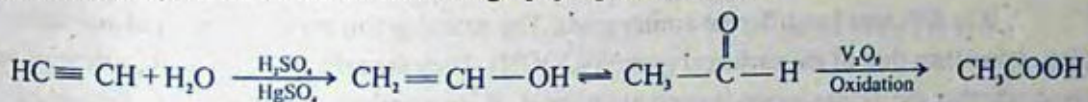

2. Acetic acid is also prepared commercially by the oxidation of ethyl alcohol. Ethyl alcohol can be commercially prepared from molasses by a process called fermentation. It is oxidized by potassium dichromate in the presence of conc. sulphuric acid to give acetaldehyde which is further oxidized under the same conditions to give acetic acid.

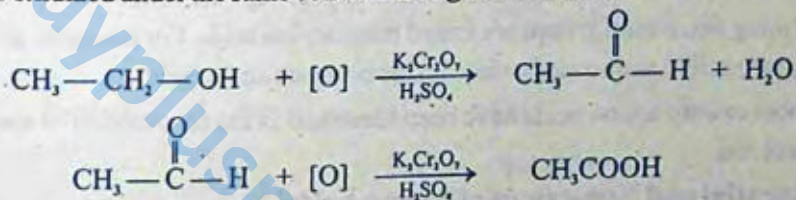

### 13.7.3 Physical Characteristics

Acetic acid is a colourless liquid with a boiling point  $118^\circ C$ . It has a strong vinegar odour and sour taste. The pure acid freezes to an ice like solid at  $17^\circ C$ , therefore, it is called glacial acetic acid. It is miscible with water, alcohol and ether in all proportions.

### 13.7.4 Reactions of Acetic Acid

Chemical reactions of acetic acid have already been discussed in the general properties of the carboxylic acids:

### 13.7.5 Uses of Acetic Acid

Acetic acid is used:

- as a coagulant for latex in rubber industry.
- in the manufacture of plastics (polyvinyl acetate) rayon (cellulose acetate) and silk.
- in medicine as a local irritant.
- as a solvent in the laboratory for carrying out reactions.
- in the manufacture of pickles.
- in the manufacture of many organic compounds like acetone, acetates and esters.

## 13.8 AMINO ACIDS

Amino acids are organic compounds containing both amino and carboxyl groups. They are represented by the general formula:

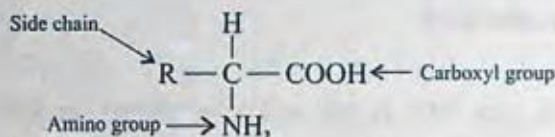

R is different for different amino acids. The amino group may be present at any carbon atom other than that of the carboxyl group (-COOH). They are referred to as  $\alpha$ ,  $\beta$ ,  $\gamma$  depending upon whether the amino group is present on the  $\alpha$ ,  $\beta$ , or  $\gamma$  carbon atom relative to the carboxyl group. Almost all the naturally occurring amino acids are  $\alpha$  amino acids. These amino acids are very important because they are the building blocks of proteins. Proteins are very important for us.

The amino acids which contain two carboxyl groups are called acidic amino acids while those containing two amino groups are called basic amino acids. For example, glutamic acid and aspartic acid are acidic amino acids while lysine is a basic amino acid.

About twenty amino acids have been identified as the constituents of most of the animal and plant proteins.

### 13.8.1 Essential and Non-essential Amino Acids

Out of twenty amino acids which are required for protein synthesis, the human body can synthesize only ten. The amino acids which body can synthesize are called non-essential amino acids. The remaining ten amino acids which the body is not able to synthesize are called essential amino acids. The essential amino acids must be supplied to our bodies through our diet because they are required for proper health and growth. The deficiency of essential amino acids may cause diseases.

### 13.8.2 Nomenclature of Amino Acids

Although amino acids can be named according to IUPAC system, they are generally known by their trivial names. These trivial names usually reflect the origin or an obvious property of the compound. Glycine, for example is so named, because it has a sweet taste (Greek glykys - sweet) and the tryosine was first isolated from cheese (from Greek tryos-cheese). For the sake of simplicity, each amino acid has been given an abbreviation which generally consists of the first three letters of the common name. For example, the simplest amino acid is glycine  $\text{H}_2\text{NCH}_2\text{COOH}$ . It may be abbreviated as Gly. Similarly, alanine  $\text{CH}_3 - \text{CH} - \text{COOH}$  may be represented as Ala.

Names, structural formulae and other features of some amino acids are given in Table 13.2.

Table 13.2 Names, structural formulae and other features of amino acids

Name	Nature	Abbreviation	Structural formula
1. Glycine	Neutral	Gly	$\begin{array}{c} \text{CH}_2 - \text{COOH} \\   \\ \text{NH}_2 \end{array}$
2. Alanine	Neutral	Ala	$\begin{array}{c} \text{CH}_3 - \text{CH} - \text{COOH} \\   \\ \text{NH}_2 \end{array}$
3. Valine	Neutral	Val	$\begin{array}{c} \text{CH}_3 - \text{CH} - \text{CH} - \text{COOH} \\   \quad   \\ \text{CH}_3 \quad \text{NH}_2 \end{array}$
4. Proline	Neutral	Pro	$\begin{array}{c} \text{H}_2\text{C} - \text{CH}_2 \\   \quad   \\ \text{H}_2\text{C} \quad \text{CHCOOH} \\ \quad   \\ \quad \text{NH} \end{array}$
5. Aspartic acid	Acidic	Asp	$\text{HOOC} - \text{CH}_2 - \text{CH} - \text{COOH} \\   \\ \text{NH}_2$
6. Glutamic acid	Acidic	Gla	$\text{HOOC} - \text{CH}_2 - \text{CH}_2 - \text{CH} - \text{COOH} \\   \\ \text{NH}_2$
7. Lysine	Basic	Lys	$\begin{array}{c} \text{CH}_2 - (\text{CH}_2)_4 - \text{CH} - \text{COOH} \\   \quad   \\ \text{NH}_2 \quad \text{NH}_2 \end{array}$
8. Histidine	Basic	His	$\begin{array}{c} \text{CH} = \text{C} - \text{CH}_2 - \text{CH} - \text{COOH} \\   \quad   \\ \text{N} \quad \text{NH} \\ \quad   \\ \quad \text{CH} \end{array}$

### 13.8.3 Structure of Amino Acids

The amino acids exist as dipolar ion called Zwitter ion. It has positive as well as negative ends within the same molecule. In the formation of Zwitter ion, the proton goes from the carboxyl group to amino group. The Zwitter ionic structure of an amino acid may be written as:

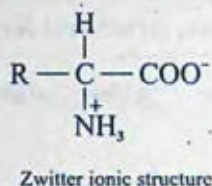
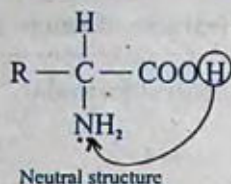

The dipolar structure is also called internal salt. All  $\alpha$ -amino acids exist largely in dipolar ionic forms.

### 13.8.4 Acidic and Basic Characters of Amino Acids

On the basis of dipolar ion structure, the acidic and basic reactions of amino acids may be represented as:

1. When an acid is added to an amino acid the carboxylate ion accepts the proton and, therefore, the basic character is due to this group.

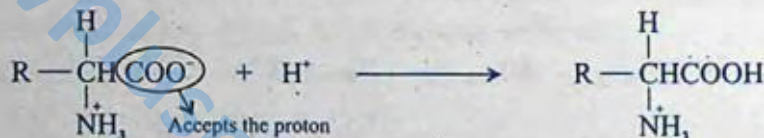

2. When an alkali is added to an amino acid,  $-\text{NH}_3^+$  group releases the proton and therefore the acidic character is due to this group.



### 13.8.5 Synthesis of Amino Acids

Amino acids can be synthesized by the following reactions.

1. By the reaction of  $\alpha$ -bromoacid with ammonia.

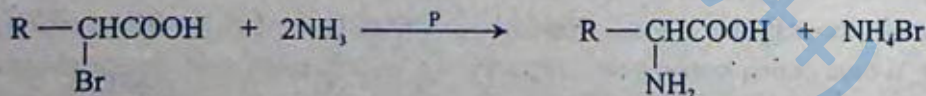
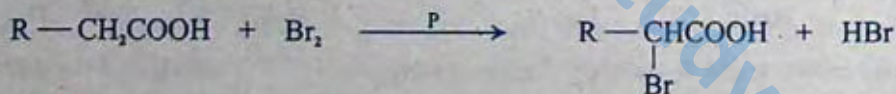

2. The Strecker Synthesis

When hydrogen cyanide is added to an aldehyde in the presence of ammonia,  $\alpha$ -amino acid is obtained.



$\alpha$ -amino nitrile upon acidic hydrolysis yields an  $\alpha$ -amino acid:

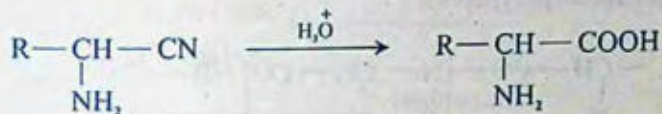

### 13.8.6 Reactions of Amino Acids

Amino acids undergo many chemical reactions characteristics of either amino group or carboxyl group.

#### i. Esterification

Amino acids form aminoester when treated with an alcohol in the presence of catalytic amount of a strong acid.

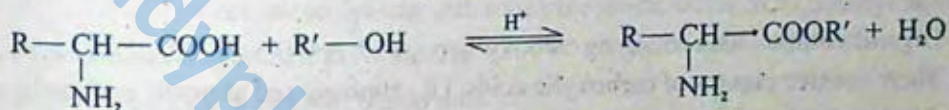

#### ii. Reaction with Nitrous Acid

Amino acids react with nitrous acid to produce  $\alpha$ -hydroxy carboxylic acid and nitrogen gas.

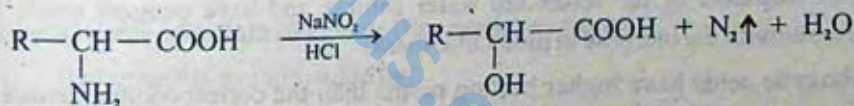

### 13.8.7 Test of Amino Acids

#### Ninhydrin Test

Ninhydrin reacts with amino acid to form an intensely coloured bluish violet product. The ninhydrin reaction is also widely used to "visualize" amino acids separated by paper chromatography.

### 13.8.8 Peptides and Proteins

Peptides are the compounds formed by the condensation of two or more same or different  $\alpha$ -amino acids. The condensation occurs between amino acids with the elimination of water. In this case, the carboxyl group of one amino acid and amino group of another amino acid gets condensed with elimination of water. The resulting  $-\text{CO}-\text{NH}-$  linkage is called a peptide linkage.

The formation of peptide is shown below:

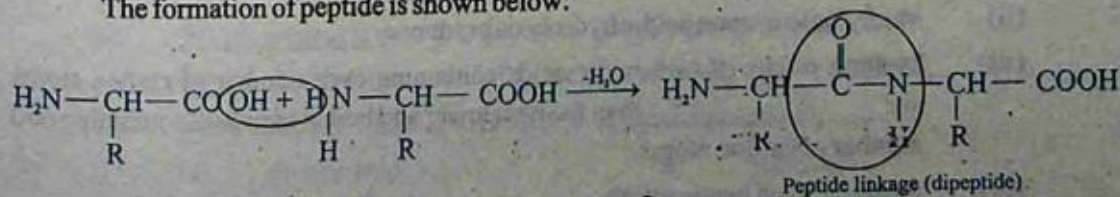

If a large number of amino acids (hundreds to thousands) are joined by peptide bonds, the resulting polyamide is called a polypeptide.

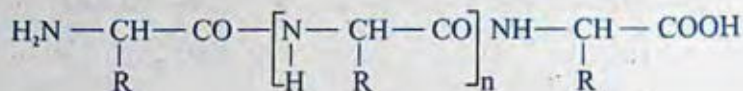

Depending upon the number of amino acids per molecule, the peptides are dipeptides, tripeptides, polypeptides, etc. The formation of peptide bonds can continue until a molecule containing several hundred thousand amino acids is formed. Such a molecule is called polypeptide or protein. By convention a peptide having molecular mass upto 10,000 is called a polypeptide while a peptide having a molecular mass more than 10,000 is called a protein.

### KEY POINTS

- Organic compounds containing carboxyl group ( $-\overset{\text{O}}{\parallel}{\text{C}}-\text{OH}$ ) are called carboxylic acids. There are two classes of carboxylic acids, i.e., aliphatic and aromatic carboxylic acids. Aliphatic carboxylic acids are also called fatty acids.
- Carboxylic acids can be produced by the oxidation of alcohols and aldehydes and by the hydrolysis of nitriles.
- Lower members of the series are water soluble and have pungent smell. Solubility decreases with the increase in molecular mass.
- Carboxylic acids have higher boiling points than the corresponding alcohols. Boiling point increases with the increase in the molar mass.
- Acid chlorides, acid amides, esters and acid anhydrides are called derivatives of carboxylic acids.
- Acetic acid is synthesized on commercial scale from acetylene.
- Carboxylic acids containing amino group in their molecules are called amino acids. They are classified as neutral, basic and acidic amino acids.
- Amino acids join together to produce peptides. A polypeptide has a molecular mass upto 10,000 whereas the molecular mass of protein is greater than 10,000.

### EXERCISE

#### Q.1 Fill in the blanks.

- Formula of malonic acid is \_\_\_\_\_.
- Methyl nitrile upon acidic hydrolysis produces \_\_\_\_\_.
- Melting points of carboxylic acids containing even number of carbon atoms are \_\_\_\_\_ than the next lower and higher members containing odd number of carbon atoms.
- Acetic acid on heating with \_\_\_\_\_ produces acetic anhydride.

- (v) Acid chloride and acid anhydride are called \_\_\_\_\_ of acid.
- (vi) Pure acetic acid is called \_\_\_\_\_.
- (vii) Formula of alanine is \_\_\_\_\_.
- (viii) Proline is a \_\_\_\_\_ amino acid.
- (ix) A peptide having a molecular mass more than 10000 is called \_\_\_\_\_.

**Q.2 Indicate True and False.**

- (i) Acetic acid exists as a dimer in benzene.
- (ii) First three aliphatic acids have fruity smells.
- (iii) Carboxylic acids on reduction with  $\text{LiAlH}_4$  produce alkenes.
- (iv) Acetic acid on dehydration produces  $\text{CO}$  and  $\text{H}_2$ .
- (v) Sodium formate on heating with soda lime produces  $\text{NaHCO}_3$  and hydrogen.
- (vi) Amino acids exist as Zwitter ion.
- (vii) Histidine is an acidic amino acid.
- (viii) A peptide having molecular mass upto 10000 is called protein.
- (ix) Phthalic acid is a monocarboxylic acid.
- (x) Formula of glycine is  $\text{CH}_2\text{COOH}$ .

**Q.3 Multiple choice questions. Encircle the correct answer.**

- (i) Acetic acid is manufactured by:
  - (a) distillation
  - (b) fermentation
  - (c) ozonolysis
  - (d) esterification
- (ii) A carboxylic acid contains
  - (a) a hydroxyl group
  - (b) a carboxyl group
  - (c) a hydroxyl and carboxyl group
  - (d) a carboxyl and an aldehydic group
- (iii) Which acid is used in the manufacture of synthetic fibre?
  - (a) formic acid
  - (b) oxalic acid
  - (c) carbonic acid
  - (d) acetic acid
- (iv) Which of the following derivatives can not be prepared directly from acetic acid.
  - (a) acetamide
  - (b) acetyl chloride
  - (c) acetic anhydride
  - (d) ethyl acetate
- (v) Which reagent is used to reduce a carboxylic group to an alcohol?
  - (a)  $\text{H}_2/\text{Ni}$
  - (b)  $\text{H}_2/\text{Pt}$
  - (c)  $\text{NaBH}_4$
  - (d)  $\text{LiAlH}_4$
- (vi) The solution of which acid is used for seasoning of food?
  - (a) formic acid
  - (b) acetic acid
  - (c) benzoic acid
  - (d) butanoic acid

- (vii) Organic compounds X and Y react together to form organic compound Z. What type of compounds can X, Y and Z be?

	X	Y	Z
(a)	alcohol	ester	acid
(b)	acid	ester	alcohol
(c)	ester	alcohol	acid
(d)	alcohol	acid	ester

- (viii) An aqueous solution of an organic compound reacts with sodium carbonate to produce carbon dioxide gas. Which one of the following could be the organic compound?

(a)	$\text{CH}_2=\text{CH}-\text{CH}_3$	(b)	$\text{CH}_3-\text{CHO}$
(c)	$\text{CH}_3\text{COOC}_2\text{H}_5$	(d)	$\text{CH}_3-\text{CH}_2-\text{COOH}$

- (ix) Which of the following is not a fatty acid?

(a)	propanoic acid	(b)	acetic acid
(c)	phthalic acid	(d)	butanoic acid

- (x) Acetamide is prepared by:

(a)	heating ammonium acetate	(b)	heating methyl cyanide
(c)	heating ethyl acetate	(d)	hydrolysis of methyl cyanide

- Q.4** Write down the structural formulae of the followings:

(i) Valeric acid	(ii) Propionic acid	(iii) Oxalic acid
(iv) Benzoic acid	(v) Acetic anhydride	(vi) Acetyl chloride

- Q.5** Write down the names of the following compounds by IUPAC system.

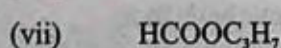
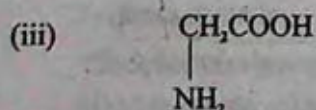
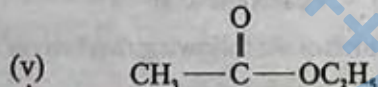
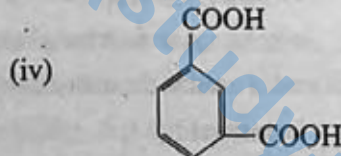
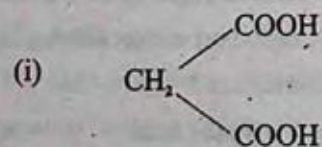

- Q.6** (a) How is acetic acid manufactured? What is glacial acetic acid?  
 (b) How would you convert acetic acid into the following compounds?  
 (i) Methane (ii) Acetyl chloride  
 (iii) Acetamide (iv) Acetic anhydride

- Q.7 (a) What are fatty acids?  
(b) What is vinegar? Describe how is vinegar prepared from ethanol?
- Q.8 How would you carry out the following conversions?  
(i) Acetic acid into acetamide (ii) Acetic acid into acetone
- Q.9 Write down the mechanisms of the following reactions.  
(i) between acetic acid and ethanol (ii) between acetic acid and ammonia  
(iii) between acetic acid and thionyl chloride
- Q.10 What happens when the following compounds are heated.  
(i) Calcium acetate (ii) Sodium formate and soda lime  
(iii) Ammonium acetate
- Q.11 What are amino acids? Explain their different types with one example in each case.
- Q.12 Write a short note on acidic and basic characters of an amino acid.
- Q.13 What is a peptide bond? Write down the formula of a dipeptide.
- Q.14 What are zwitter ions?
- Q.15 What are  $\alpha$  amino acids, proteins and peptides? How are they related?
- Q.16 Study the facts given in (a), (b) and (c) below and then answer questions which follow.
- (a) A is an organic compound made up of C, H and O. It has a vapour density 15.  
[Hint: Molecular mass = 2 x vapour density].
- (b) On reduction A gives a compound 'X' which has the following properties.  
(i) X is a colourless liquid miscible with water.  
(ii) X is neutral to litmus.  
(iii) When X is warmed with a few drops of conc.  $H_2SO_4$ , followed by a little salicylic acid a characteristic smell is produced.
- (c) When X is subjected to strong oxidation, it gives compound B, which has the following properties.  
(i) B is a pungent smelling mobile liquid.  
(ii) It is miscible with water, alcohol or ether.  
(iii) It is corrosive and produces blisters on contact with skin.  
(iv) B can be obtained by passing the vapours of A with air over platinum black catalyst.  
(v) B liberates  $H_2$  with sodium.  
(vi) It gives  $CO_2$  with  $NaHCO_3$ .
1. What is the molecular mass of A?
  2. Identify A, X and B.
  3. Give five appropriate reactions to confirm the identities of A, X and B.
  4. State one large-scale use of either A, X or B.

## CHAPTER

## 14

## MACROMOLECULES

## In this chapter you will learn

1. The concepts of polymerization and macromolecules.
2. Types of polymerization and products of these polymerizations, e.g., polyvinyl chloride, polystyrene, polyvinyl acetate, polyamides, polyester and epoxy resins.
3. About life molecules, for example, carbohydrates, lipids, proteins, enzymes and nucleic acids.

## 14.1 INTRODUCTION

Acceptance of the macromolecular hypothesis came about in 1920's largely because of the efforts of Staudinger. He proposed long chain formulae for polystyrene, rubber and polyoxymethylene. Macromolecules or polymers are described as large molecules built up from small repeating units called monomers. The development of the process of polymerization is, perhaps, one of the most significant things chemists have done, where it has had the major effect on everyday life. The world would be a totally different place without artificial fibres, plastics, etc. One of the most significant changes has been the gradual replacement of natural materials such as wood and cotton with manmade synthetic polymers. For better or worse we are living in a "plastic" society.

The word polymer is derived from Greek, poly means 'many' and mer means 'parts'. Macromolecules can be classified into the following types, Fig 14.1.

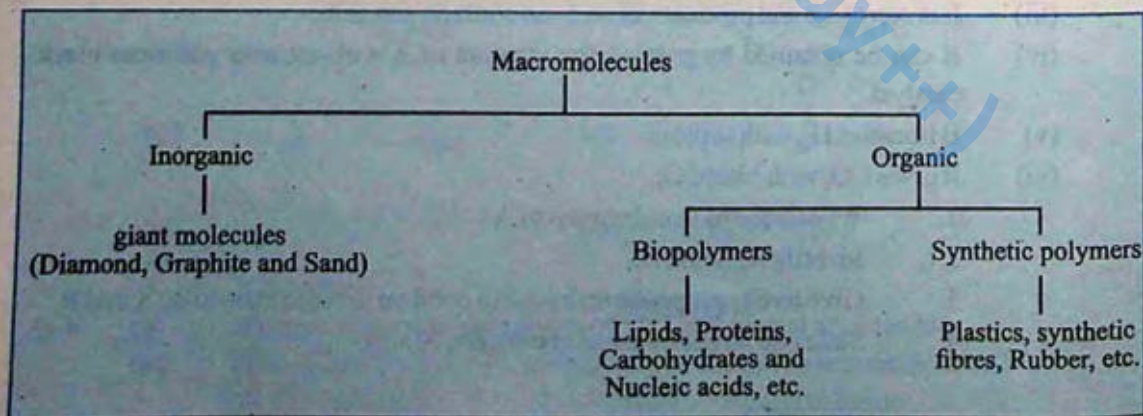

Fig. 14.1 Classification of macromolecules

## 14.2 STRUCTURE OF POLYMERS

A polymer is a large molecule build up by the repetition of small and simple chemical units known as monomers. In some cases the repetition is linear while in others, it is branched or interconnected to form three dimensional network Fig 14.2.

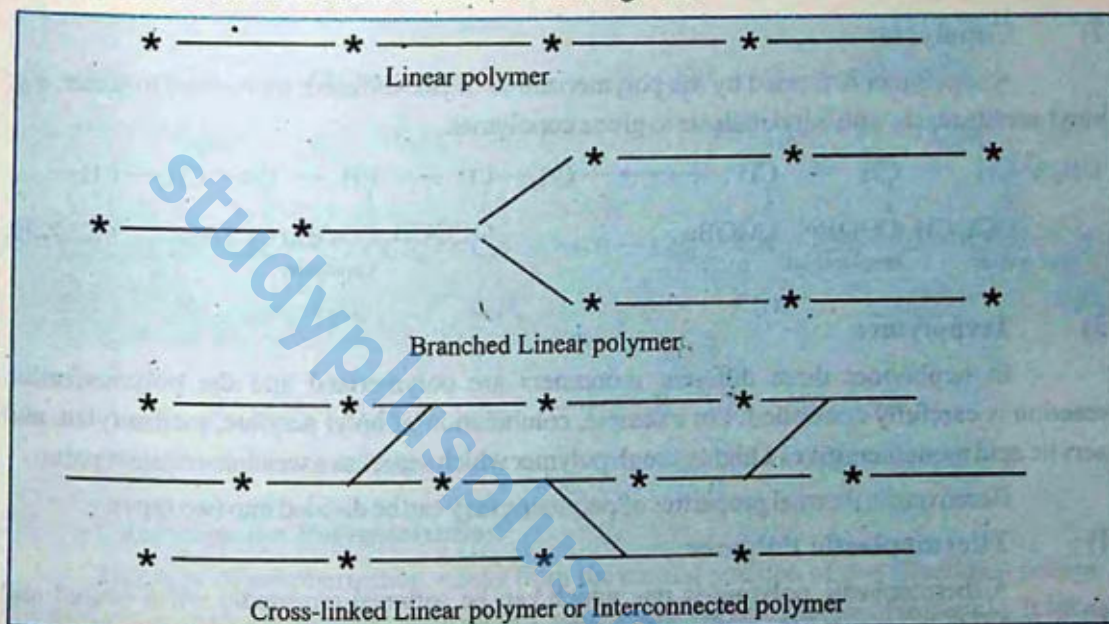
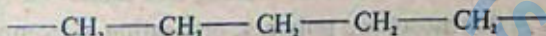

Fig. 14.2 Three ways of polymerization

The length of the polymer chain is specialized by the number of repeating units in the chain known as the degree of polymerization (DP), for example, in linear polythene.



The repeating unit is  $\text{—}(\text{CH}_2\text{—CH}_2)_n\text{—}$ , where  $n$  is a large number.

The molecular mass of the polymer is the product of the molecular mass of the repeating unit and the DP. For example, polyvinyl chloride, a polymer of DP 1000, has a molecular mass.

$$\text{Mol. mass} = \text{Mol. mass of the repeat unit} \times \text{DP}$$

$$\text{—}(\text{CH}_2\text{—}\underset{\text{Cl}}{\text{CH}_2})_n\text{—} = 63 \times 1000 = 63000$$

Most high molecular mass polymers are useful for making plastics, rubbers or fibres, etc. and have molecular masses between 10,000 to 1,000,000. The properties of polymeric materials vary widely depending upon the chemical composition and structure of the macromolecule.

## 14.3 TYPES OF POLYMERS

The polymers formed are of the following types:

### 1) Homopolymer

A homopolymer is formed by the polymerization of a single type of monomers.

For example, the polymerization of vinyl acetate.

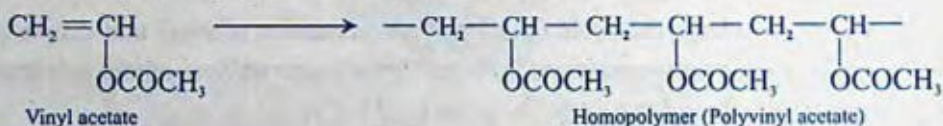

## 2) Copolymer

A copolymer is formed by the polymerization of two different monomers together, e.g; vinyl acetate reacts with butyl maleate to give a copolymer.

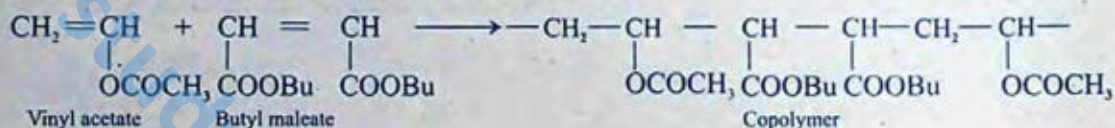

## 3) Terpolymer

In terpolymer three different monomers are polymerized and the polymerization reaction is carefully controlled. For example, combination of butyl acrylate, methacrylate and acrylic acid monomers gives a highly tough polymer which serves as a weather-resistant paint.

Based on the thermal properties of polymers, they can be divided into two types.

### i) Thermoplastic Polymer

A thermoplastic polymer is one which can be softened repeatedly when heated and hardened when cooled with a little change in properties. For example; PVC pipes, plastic toys, etc.

### ii) Thermosetting Polymer

The polymers which become hard on heating and cannot be softened again are called thermosetting polymers. A thermosetting polymer, on heating, decomposes instead of melting. For example, synthetic varnish, epoxy resins, etc.

## 14.4 POLYMERIZATION PROCESS

In 1929, W.H. Carothers suggested a classification of the polymerization process into two types depending upon the way the polymers are formed.

1. Addition polymerization
2. Condensation polymerization

### 1) Addition Polymerization

It is a free-radical addition reaction which involves initiation, propagation and termination steps. For example, polymerization of styrene. Addition polymerization is catalyzed by thermal or photochemical decomposition of organic peroxides to give free radicals.

#### Initiation

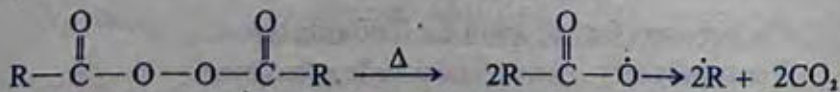

## Propagation

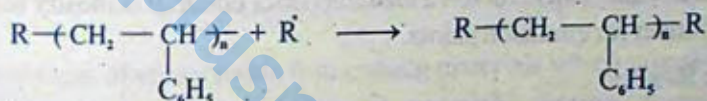
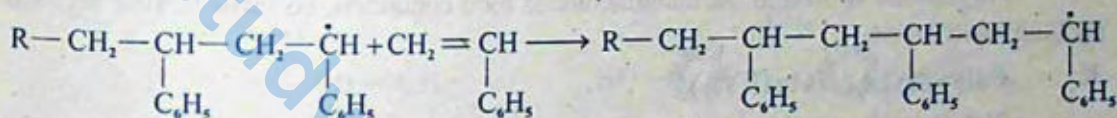
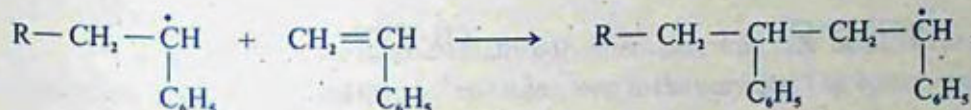

## 2. Condensation Polymerization

This type of polymerization results from the mutual reaction of two functional groups. The reaction usually involves the removal of a water molecule or a methanol molecule. It takes place at both ends of the growing chain. For example; dicarboxylic acids or esters combine with diols to get the desired polymer like nylon and polyester fibre. Such polymerizations are generally ionic in nature.

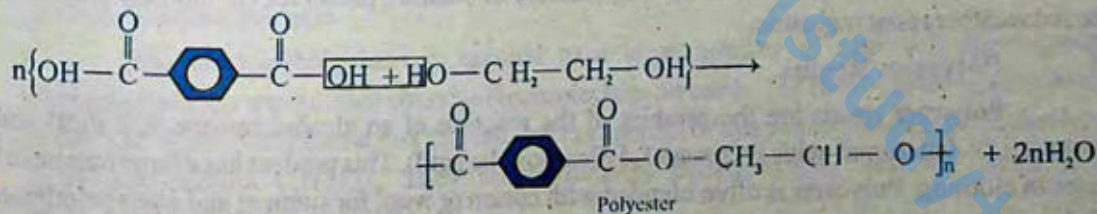

## 14.5 BRIEF DESCRIPTION OF SYNTHETIC POLYMERS

## 1. Polyvinyl Chloride (PVC)

It is an addition polymer obtained by polymerizing vinyl chloride at 52°C and 9 atmospheric pressure.

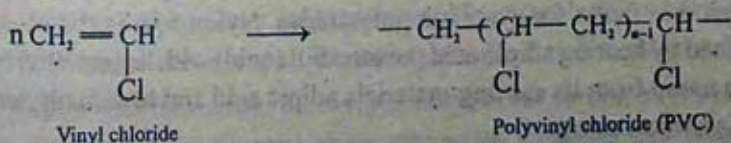

Addition of a plasticizer improves the flexibility of the polymer. It is widely used in floor coverings, in pipes, in gramophone recorders, etc.

## 2. Polystyrene

It is also an addition polymer and is obtained by the polymerization of styrene in the presence of a catalyst.



Polystyrene is used in the manufacture of food containers, cosmetic bottles, toys and packing material, etc.

## 3. Polyvinyl Acetate (PVA)

PVA is a colourless, non-toxic resin. It is supplied in a number of grades differing in the degree of polymerization. The resin has a characteristic odour. It is mostly used as an adhesive material and as a binder for emulsion paints.

## 4. Acrylic Resins

These are closely related to the vinyl resins. The most important monomers of acrylic resins are methylmethacrylate, acrylic acid and butyl acrylate. The acrylic fibres are based largely on acrylonitrile.

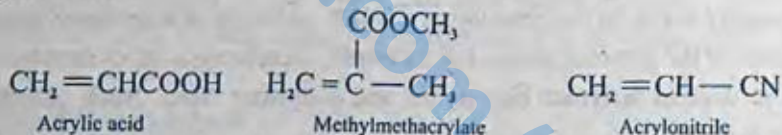

Acrylic resins are used in the manufacture of plastics, paints for car industry and water based weather resistant paints.

## 5. Polyester Resins

Polyester resins are the product of the reaction of an alcohol (ethane 1, 2 diol) and aromatic bi-functional acids (benzene 1,4 dicarboxylic acid). This product has a large number of uses in clothing. Polyester is often blended with cotton or wool for summer and winter clothing. Polyester resins are also used for making water tanks, etc. (For a chemical equation please see under condensation polymerization).

## 6) Polyamide Resins

These resins are formed by the condensation of polyamines with aliphatic dicarboxylic acids. One of the most famous condensation polymers discovered is Nylon. The word Nylon has been accepted as a generic name for synthetic polyamides. Nylon 6, 6 is the most important polyamide. It is obtained by heating adipic acid (hexanedioic acid) with hexamethylene diamine. Nylon 6,6 derives its name from its starting materials adipic acid and hexamethylene diamine, both of which have six carbon atoms.

Nylon is mainly used as a textile fibre. It has a combination of high strength, elasticity,

toughness and abrasion resistance.

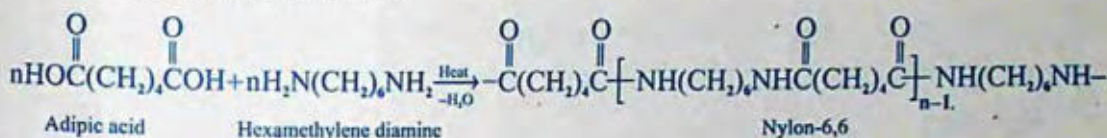

## 7. Epoxy Resins

The epoxy resins are fundamentally polyethers but retain their name on the basis of their starting materials and the presence of epoxide group in the polymer. The epoxy resin is made by condensing epichlorohydrin with diphenylol propane.

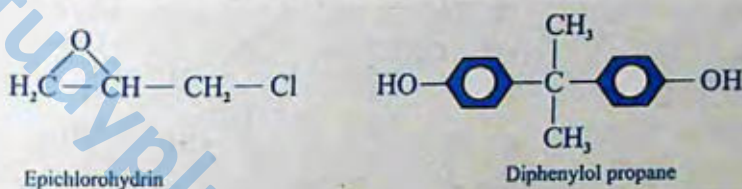

The major use of epoxy resins is in coating materials which give toughness, flexibility, adhesion and chemical resistance. Industrial materials, thermal power stations, packing materials are coated with epoxy paints. Dams, bridges, floors, etc. are painted with epoxy resins.

## 14.6 BIOPOLYMERS

Most biologically important substances are organic compounds built up from skeleton of carbon atoms. Many of them are very large molecules and most of these are polymers. The four major classes of organic compounds in living cells are carbohydrates, lipids, proteins and nucleic acids.

### 14.6.1 Carbohydrates

The term carbohydrate is applied to a large number of relatively heterogeneous compounds. They are the most abundant biomolecules on earth. The name carbohydrate (hydrate of carbon) is derived from the fact that the first compound of this group which was studied had an empirical formula  $\text{C}_x(\text{H}_2\text{O})_y$ . They are commonly called 'sugars' and are 'polyhydroxy compounds' of aldehydes and ketones.

### 14.6.2 Classification of Carbohydrates

The commonly described classification is given below.

#### 1. Monosaccharides

These are simple sugars which cannot be hydrolyzed. They have an empirical formula  $(\text{CH}_2\text{O})_n$  where  $n = 3$  or some large number. Monosaccharides are either aldoses (aldehydic group) or ketoses (ketonic group). Common examples are glyceraldehyde, glucose, fructose, etc.

Sugars with five carbon atoms (pentoses) or six carbon atoms (hexoses) are more stable as cyclic structures than as open chain structures. Glucose and fructose are very common

examples of hexoses, both of which have molecular formula,  $C_6H_{12}O_6$ .

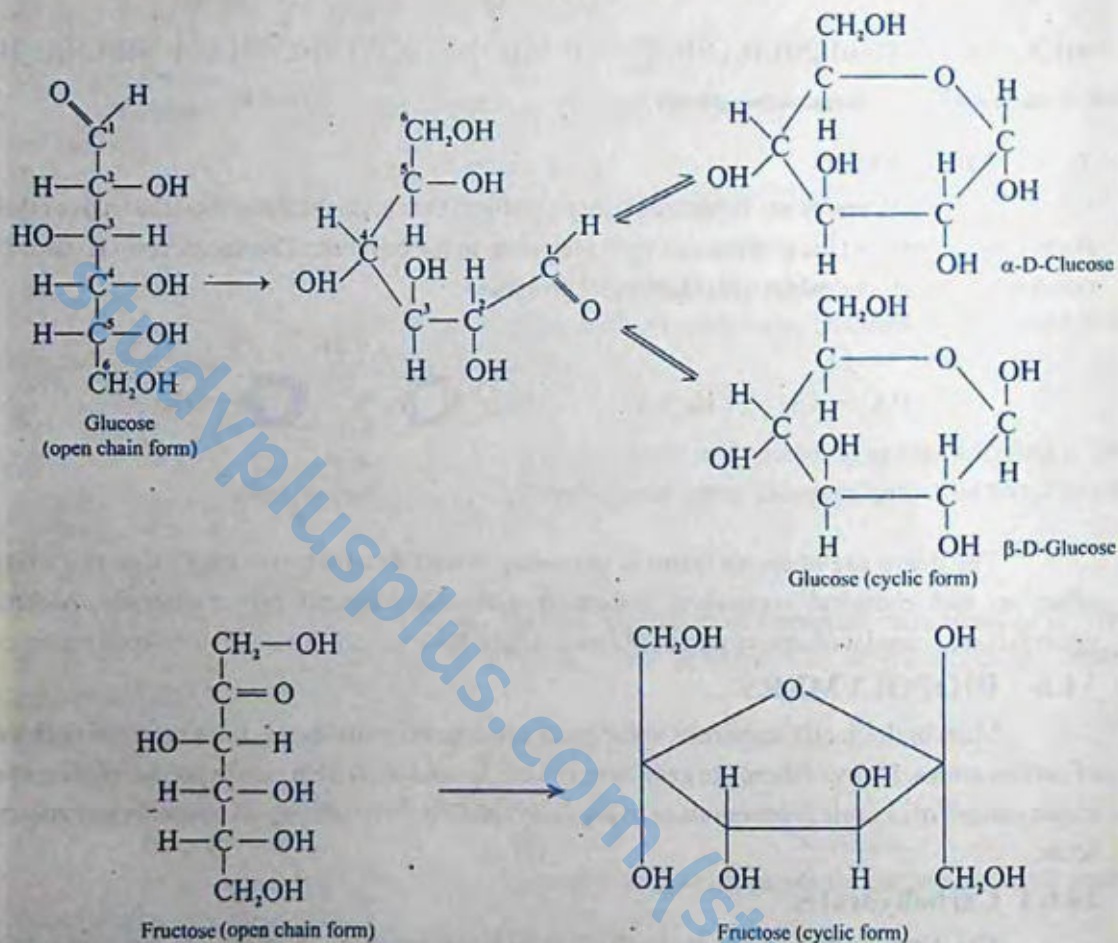

Glucose also called dextrose, grape sugar or blood sugar, occurs naturally in both combined and free states. In the free state, it is present in most sweet fruits and in honey. Small quantities of glucose are also present in human blood and urine. In the combined state it forms a major component of many disaccharides and polysaccharides. It is the source of energy in our body.

Fructose is also found in combined and free states. It is used as a sweetening agent in confectionery and as a substitute of cane sugar. Other examples of monosaccharides are galactose and mannose.

## 2. Oligosaccharides

The oligosaccharides are formed when two to nine monosaccharide units combine by the loss of water molecules. This results in the formation of a glycosidic linkage. For example; sucrose which is a common table sugar, is a disaccharide of glucose and fructose.



### i) Starch

Starch is the most important source of carbohydrates in human diet. The chief commercial sources of starch are wheat, rice, maize, potatoes and barley. Starch is a polymer of  $\alpha$ -D-glucose.

Starch is not a pure compound. It is a mixture of two polysaccharides, amylose and amylopectin which can be separated from one another. Amylose is soluble in water and gives a deep blue colour with iodine while amylopectin is insoluble and gives no colour. Natural starch consists of 10 to 20% amylose and 80 to 90% amylopectin. It is used in coating and sizing of paper to improve the writing qualities. It is also used in laundering and in the manufacture of glucose and ethyl alcohol.

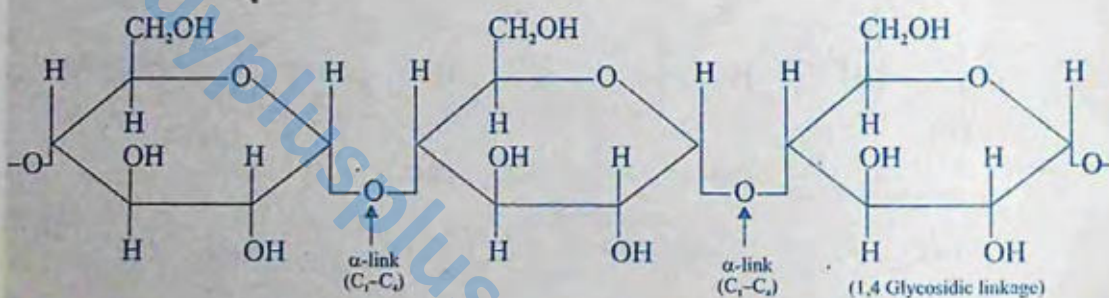

Structure of Amylose (Polymer of  $\alpha$ -D-glucose)

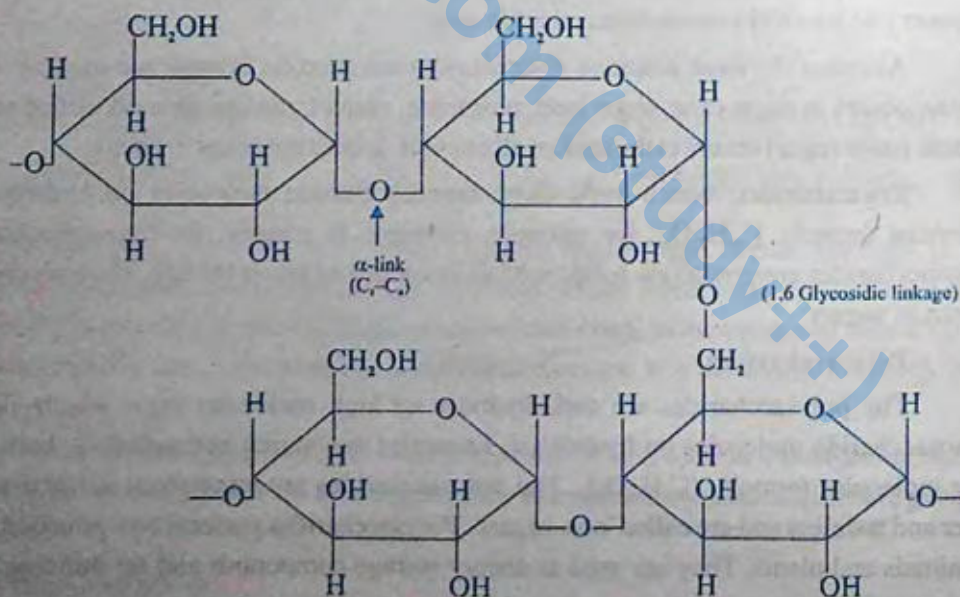

Structure of Amylopectin

## ii) Cellulose

By far, the most abundant structural polysaccharide is cellulose. Some 100 billion tons of cellulose are produced every year by plants. For example, cotton is 99% cellulose and the woody parts of trees are generally more than 50% cellulose. It is a polymer of  $\beta$ -D-glucose.

It is present mainly in the plant kingdom but also occurs in some marine animals. It is an unbranched polymer consisting of a large number (up to 2500) of glucose residues joined to each other through  $\beta$ -1 $\rightarrow$ 4 linkages.

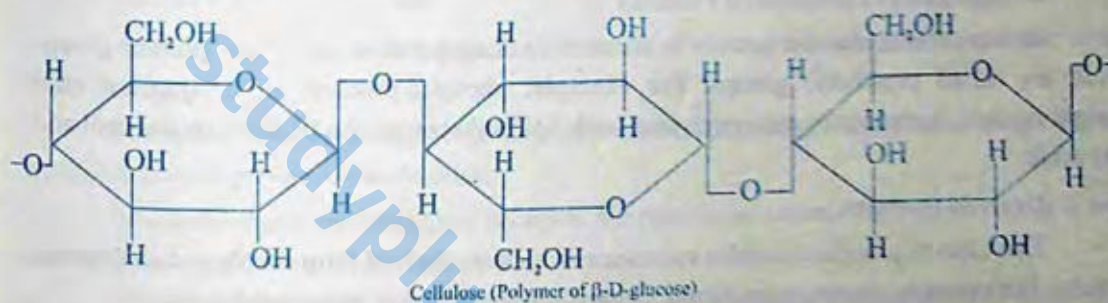

## iii) Glycogen

It occurs mainly in the liver and muscles where it represents the main storage polysaccharide in the same way as starch functions in plant cells. Glycogen is therefore also called 'animal starch'. Its structure closely resembles with that of amylopectin having 1 $\rightarrow$ 4 and 1 $\rightarrow$ 6 glycosidic linkages. Human glycogen is a much more branched molecule than amylopectin. On hydrolysis it yields glucose units.

### 14.6.3 Proteins

Proteins are extremely complicated molecules of living things. They are the nitrogenous compounds made up of a variable number of amino acids. The human body probably contains at least 10,000 different kinds of proteins. The name protein is derived from the Greek word *proteios* meaning of prime importance.

Proteins are present in all living organisms and without proteins life would not be possible. They are present in muscles, skin, hair and other tissues that make up the bulk of the body's non-bony structure.

All proteins contain the elements carbon, hydrogen, oxygen and nitrogen. They may also contain phosphorus and traces of other elements like iron, copper, iodine, manganese, sulphur and zinc. Proteins are very high molecular weight macromolecules. All proteins yield amino acids upon complete hydrolysis. Thus proteins may be defined as the high molecular weight organic materials, which upon complete hydrolysis, yield amino acids.

### 14.6.4 Classification of Proteins

Based on the physico-chemical properties, proteins may be classified into three types.



the tertiary structure of proteins.

#### 14.6.6 Denaturation of Proteins .

The structure of proteins can be disrupted easily by heat, change in pH and under strongly oxidizing or reducing conditions. Under such conditions the proteins undergo denaturation. The most familiar example of denaturation is the change that takes place in albumin, the principal component of egg white, when it is cooked. In this particular case the change is irreversible.

#### 14.6.7 Importance of Proteins

1. Proteins take an essential part in the formation of protoplasm which is the essence of all forms of life.
2. Nucleoproteins which are complexes of proteins with nucleic acids serve as carriers of heredity from one generation to the other.
3. Enzymes which are biological catalysts are protein in nature. Without them life is not possible.
4. Many proteins have specialized functions. Haemoglobin acts as a carrier of  $O_2$ . Some proteins act as hormones which have regulatory functions, for example; insulin, thyroxine etc.

Industrially proteins have great importance. We are familiar with the use of leather made by tanning of hides. This is essentially a precipitation of the proteins with tannic acid.

Gelatin is obtained by heating bones, skin and tendons in water. It is used in bakery goods. Caesein is another protein used in the manufacture of buttons and buckles.

#### 14.6.8 Lipids

Lipids (Greek, lipos means fat) are naturally occurring organic compounds of animals and plants origin which are soluble in organic solvents and belong to a very heterogeneous group of substances.

Lipids have the following characteristics:

1. They are insoluble in water and soluble in nonpolar solvents, e.g., ether, chloroform and benzene, etc.
2. Their primary building blocks are fatty acids, glycerol and sterols.
3. They are utilized by the living organisms.

Fats and oils are the most important lipids found in nature. They are one of the three major "food factors" needed for human body, the other two being proteins and carbohydrates. Fats and oils are widely distributed in various types of foods and are of great nutritional value.

Not only the edible fats and oils occupy a place of pride in human diet but they also find use as raw materials for the manufacture of soaps and detergents, paints, varnishes, polishes, cosmetics, printing inks and pharmaceuticals.

### 14.6.9 Sources of Fats and Oils

Fats and oils come from a variety of natural sources like animals, plants and marine organisms. Animal fats are located particularly in adipose tissue cells. Butter and ghee are a special type of animal fats which are made from milk. Vegetable oils are chiefly present in seeds and nuts of plants. Marine oils are obtained from sea animals like salmon and whales, etc.

### 14.6.10 Structure and Composition of Fats and Oils

Animal and vegetable fats and oils have similar chemical structures. They are triesters formed from glycerol and long chain acids called fatty acids.

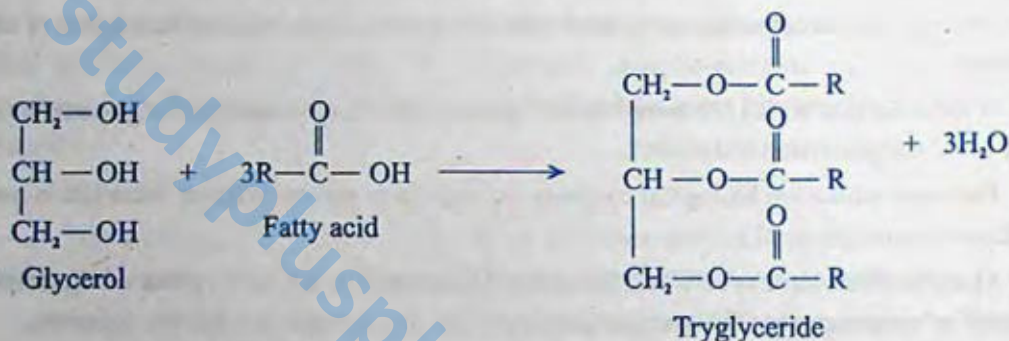

A triester of glycerol is called a triglyceride or glyceride. The degree of unsaturation of the constituent fatty acid determines whether a triglyceride will be a solid or a liquid.

The glycerides in which long-chain saturated acid components predominate tend to be solid or semi-solid and are termed as fats. On the other hand, oils are glycerol esters which contain higher proportion of unsaturated fatty acid components.

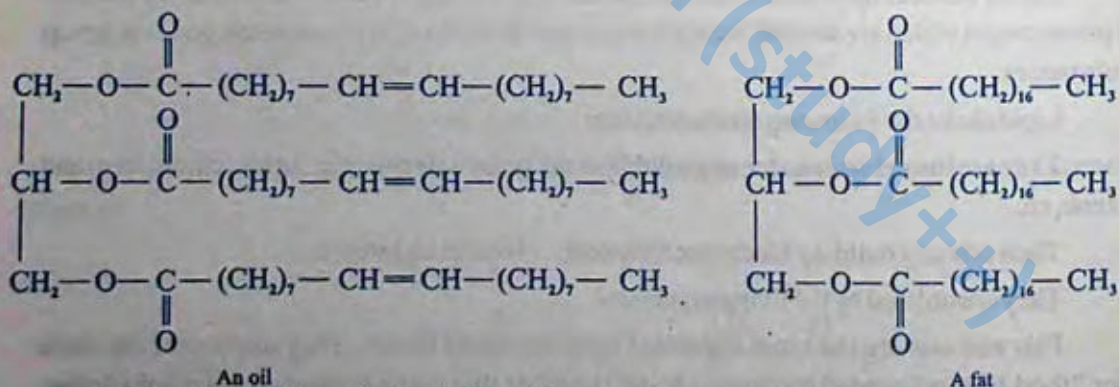

The melting points of mixed glycerides would depend on the extent of unsaturated fatty acid components in the molecule. The poly unsaturated glycerides therefore have very low melting points and are liquids (oils). Chemically common oils and fats are the mixture of saturated and unsaturated triglycerides, present in various ratios.

### 14.6.11 Classification

Lipids are classified as:

#### 1. Simple Lipids

These are esters of fatty acids with glycerol. For example, common fats and oils.

#### 2. Compound Lipids

These contain radicals in addition to fatty acids and alcohols and include glycerol phospholipids, sphingolipids, lipoproteins and lipopolysaccharides.

#### 3. Derived or Associated Lipids

They are the hydrolytic products of the above mentioned compounds. Sterols, vitamin D and terpenes belong to this class of lipids.

### 14.6.12 Physical Properties

1. Oils and fats may either be liquid or noncrystalline solids at room temperature.
2. When pure they are colourless, odourless and tasteless.
3. They are insoluble in water and readily soluble in organic solvents like diethyl ether, acetone, carbon tetrachloride and carbon disulphide.
4. They readily form emulsions when agitated with  $H_2O$  in the presence of soap or other emulsifiers.
5. They are poor conductor of heat and electricity and therefore serve as excellent insulator for the animal body.

### 14.6.13 Chemical Properties

#### 1. Hydrolysis

Triglycerides are easily hydrolyzed by enzymes called lipases to fatty acids and glycerol.

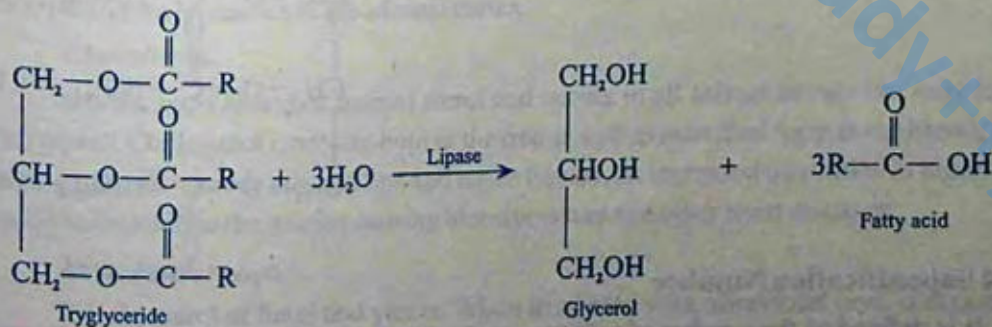

#### 2. Saponification

It is the hydrolysis of a fat or an oil with an alkali to form soap (salt of fatty acid) and glycerol.

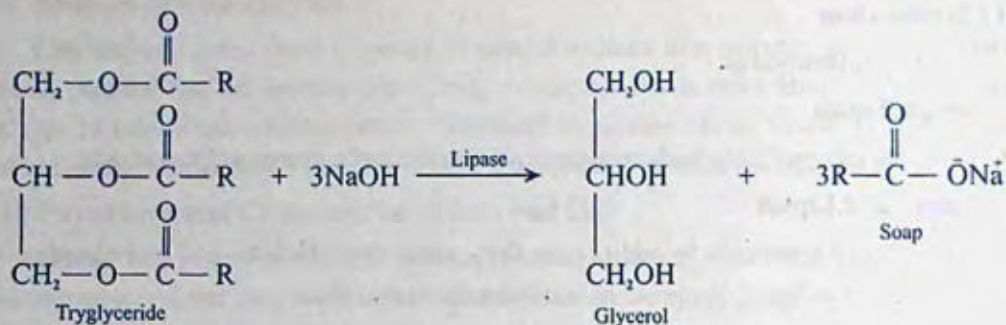

### 3. Hardening of Oils

Unsaturated glycerides react with hydrogen in the presence of a nickel catalyst to give saturated glycerides. The result is the conversion of a liquid glyceride (an oil) into a semi-solid glyceride (a fat).

This reaction is used commercially to harden vegetable oils for the production of vegetable ghee or margarine. Hardened oils are also extensively used for making soaps and candles.

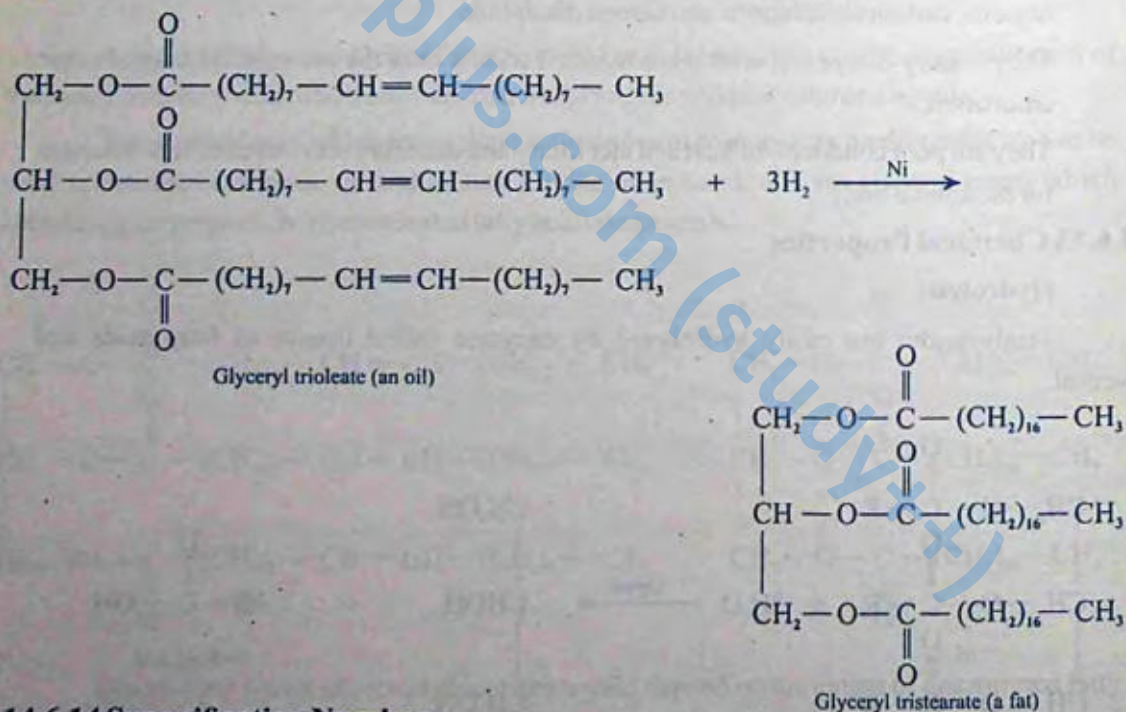

#### 14.6.14 Saponification Number

It is defined as the number of milligrams of potassium hydroxide or sodium hydroxide required to saponify one gram of the fat or oil. For example, one mole of glycerol tripalmitate (mol. wt = 807) requires 168,000 mg of KOH for saponification. Therefore, one gram of fat will require  $168,000/807$  mg of KOH. Hence the saponification number of glycerol tripalmitate is 208.

### 14.6.15 Rancidity of Fats or Oils

Fats or oils are liable to spoilage and give off an odour known as rancidity. It is mainly caused by the hydrolytic or oxidative reactions which release foul smelling aldehydes and fatty acids. Oils from sea animals which contain a relatively high proportion of unsaturated acid chains deteriorate rapidly.

### 14.6.16 Iodine Number

The extent of unsaturation in a fat or an oil is expressed in terms of its iodine number. It is defined as the number of grams of iodine which will add to 100 grams of a fat or an oil. The value of iodine number depends on the number of double bonds present in the acid component of the glycerides. The glycerides with no double bonds have zero iodine number.

### 14.6.17 Acid Number

The acid number of a fat or an oil indicates the amount of free fatty acids present in it. It is expressed as the number of milligrams of potassium hydroxide required to neutralize one gram of fat.

### 14.6.18 Steroids

Steroids are naturally occurring lipids. Their parent nucleus has perhydrocyclopentanophenanthrene component which consists of three six-membered rings (A, B and C) and one five-membered ring (D). These rings are joined or fused to each other and have a total of 17-C atoms. Very small variations in the bonding of atoms in the ring and in the groups attached to them give rise to compounds that are remarkably diverse in their biological functions.

Some of the natural occurring compounds belonging to steroids are cholesterol, ergosterol, male and female sex hormones and the hormones of the adrenal cortex.

#### 1. Cholesterol

It is the most abundant animal sterol and occurs in all animal tissues but only in a few higher plants. Cholesterol is present both in the free as well as esterified form in the blood, animal tissues, egg, yolk, various oils and fats and nerve tissues. Its increased quantities in blood makes plaque like deposits in the arteries causing blood pressure and other heart diseases.

#### 2. Ergosterol

It is the sterol of fungi and yeasts. When irradiated with ultraviolet rays, it is converted into ergocalciferol or vitamin  $D_2$ .

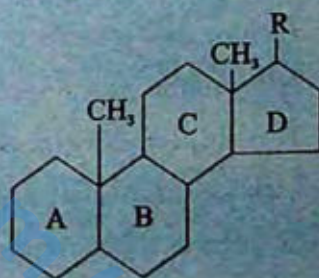

Structure of Steroid Nucleus

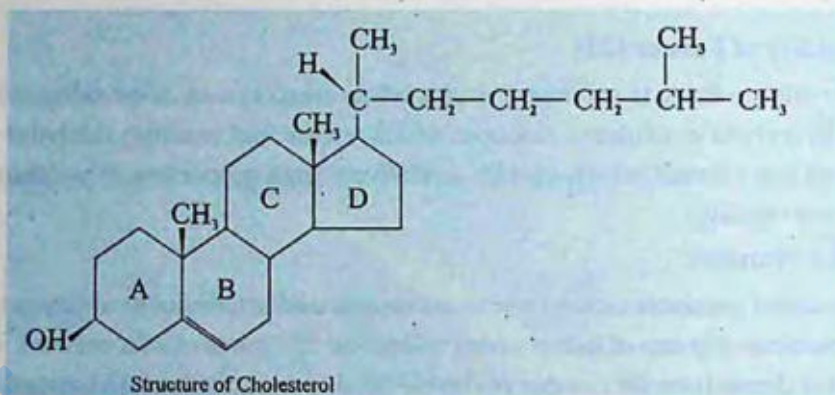

### 3. Phospholipids

Phospholipids are molecules of enormous biological importance. In the compounds, two of the hydroxyl groups are esterified with fatty acids and third forms a link with phosphoric acid or a derivative of phosphoric acid.

#### 14.6.19 Importance of lipids

1. They are good source of energy and make the food more palatable.
2. They exert an insulating effect on the nervous tissues.
3. They are good energy reservoirs in the body.
4. Lipids are an integral part of cell protoplasm and cell membranes.
5. Some lipids act as precursors of very important physiological compounds. For example, cholesterol is the precursor of steroid hormones.

#### 14.6.20 Enzymes

Enzymes can be defined as the reaction catalysts of biological systems produced by living cells and are capable of catalyzing chemical reactions. Typically enzymes are macromolecules with molecular masses ranging into millions. Two remarkable properties of enzymes are their extraordinary specificity – each enzyme catalyzes only one reaction or one group of closely related reactions – and their amazing efficiency – they may speed up reactions by factors of upto  $10^{25}$ . Each enzyme molecule possesses a region known as the active site and the substrate binds itself with this active site. Enzymes are either pure proteins or contain proteins as essential components and in addition require non-protein components which are also essential for their activity.

The protein component of the enzyme is called apoenzyme and the non-protein component is called the co-factor or co-enzyme. The co-factors include inorganic ions and

complex organic or metallo-organic molecules. Important inorganic co-factors along with their respective enzymes include  $\text{Fe}^{2+}$  (chrome oxidase)  $\text{Zn}^{2+}$  (carbonic anhydrase) and  $\text{Mg}^{2+}$  (glucose 6-phosphatase), etc. Many enzymes contain vitamins as their co-factors, for example; nicotinamide adenine dinucleotide contains nicotinamide vitamin and thiamine pyrophosphatase contains vitamin  $\text{B}_1$ . While naming the enzymes, suffix-"ase" is added to the name of the substrate on which the enzyme acts, for example, urease, sucrase, cellulase are the enzymes, which act upon the substrates urea, sucrose and cellulose respectively.

#### 14.6.21 Classification of Enzyme

The commission on enzyme, appointed by the International Union of Bio-Chemistry (IUB) classified enzymes into six main types.

##### 1. Oxidoreductases

These enzymes catalyze oxidation-reduction reactions. Common examples are oxidase, dehydrogenase and peroxydase.

##### 2. Transferases

These enzymes bring about an exchange of functional group such as phosphate or acyl between two compounds. For example; phospho-transferases, etc.

##### 3. Hydrolases

These enzymes catalyze hydrolysis. They include proteases called protolytic enzymes.

##### 4. Lyases

These enzymes catalyze the addition of ammonia, water or carbon dioxide to double bonds or removal of these to form double bonds, for example phospho-glyceromutases.

##### 5. Isomerases

These enzymes catalyze the transfer of groups within molecules to yield isomeric forms of the substrate. An example is the conversion of fumaric acid to maleic acid in the presence of fumarase enzyme.

##### 6. Ligases

These enzymes link two molecules together through the breaking of high energy bonds, for example; acetyl-S-COH, a carboxylase and succinic thiokinase.

#### 14.6.22 Properties of Enzymes

##### 1. Specificity

Enzymes are specific in their action which means that an enzyme will act on only one substrate or a group of closely related substrates. For example, hexokinase catalyses the conversion of hexoses like glucose, fructose and mannose to their 6-phosphate derivatives but glucokinase is specific for glucose only.

##### 2. Protein Nature

Enzymes with few exceptions are protein in nature. They are produced by living cells but

act *in vivo* as well as *in vitro*.

### 3. The Direction of Enzyme Reactions

Most enzymatic reactions are reversible, i.e., the same enzyme can catalyze reactions in both directions.

### 4. Isoenzymes

These are the enzymes from the same organisms which catalyze the same reaction but are chemically and physically distinct from each other.

## 14.6.23 Factors Affecting Enzyme Activity

### 1. Enzyme Concentration

The rate of an enzymatic reaction is directly proportional to the concentration of the substrate. The rate of reaction is also directly proportional to the square root of the concentration of enzyme. It means that the rate of reaction also increases with the increasing concentration of enzyme.

### 2. Temperature

The enzymatic reaction occurs best at or around 37°C which is the average normal body temperature. The rate of chemical reactions is increased by a rise in temperature but this is true only over a limited range of temperature. The enzymes usually destroy at high temperature. The activity of enzymes is reduced at low temperature. The temperature at which an enzyme reaction occurs the fastest, is called its optimum temperature.

### 3. Effect of pH

Just like temperature, there is also an optimum pH at which an enzyme will catalyze the reaction at the maximum rate. For example, the optimum pH of salivary amylase is 6.4 to 6.9.

### 4. Other Substances

The enzyme action is also increased or decreased in the presence of some other substances such as co-enzymes, activators and inhibitors. For example, some enzymes consist of simple proteins only such as insulin. Most of the enzymes are, however, the combination of a co-enzyme and an apo-enzyme. Activators are the inorganic substances which increase the enzyme activity. For example;  $Mg^{2+}$  and  $Zn^{2+}$  ions are the activators of phosphatase and carbonic anhydrase enzymes respectively. Inhibitors are the substances which reduce the enzyme activity.

### 5. Radiation

Generally enzymes are readily inactivated by exposure to ultraviolet light, beta rays, gamma rays and X-rays.

## 14.6.24 Importance of Enzymes

Enzymes are of great biological importance and are of great help in the diagnosis of certain diseases. Some examples are, alkaline phosphatase is raised in rickets and obstructive jaundice, lactic dehydrogenase or LDH-1 is raised in heart diseases. Many enzymes have proved

very useful as drugs. For example; thrombin is used locally to stop bleeding. Many enzymes are used for cancer treatment, for example, L-asparaginase has proved very useful in the treatment of blood cancer in children.

### 14.6.25 Nucleic Acids

Nucleic acids were first demonstrated in the nuclei of pus cells in 1868 and in sperm heads in 1872 by Friedrik Miescher. They are present in every living cell as well as in viruses and have been found to be the essential components of the genes. They contain in their structure the blue-prints for the normal growth and development of each and every living organism. The nucleic acids are responsible for the two fundamental functions which are common to all living organisms. These are (a) their ability to reproduce, store and transmit genetic information and (b) to undergo mutation. Two types of nucleic acids have been discovered, deoxyribonucleic acid (DNA) and ribonucleic acid (RNA). In the body nucleic acids occur as part of the conjugated proteins called nucleoproteins. The nucleic acids direct the synthesis of proteins. Cancer research involves an extensive study of nucleic acids.

### 14.6.26 Components of Nucleic Acids

Both DNA and RNA are formed by joining together a large number of nucleotide units or mononucleotides units, each of which is a nitrogenous base sugar phosphoric acid complex.

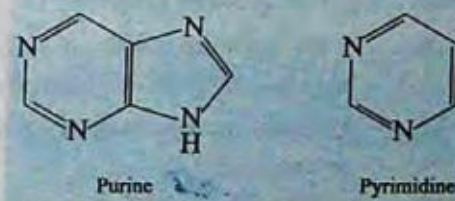

Nitrogenous bases are either purine or pyrimidine derivatives. Purines include adenine and guanine whereas pyrimidines include, cytosine, uracil and thymine. A nucleoside is a combination of nitrogenous base (purine or a pyrimidine) with a sugar (ribo or deoxyribose). Depending upon the presence of ribo or a deoxyribo, nucleoside can either be a ribonucleoside or deoxyribonucleoside. Deoxyribonucleic acid (DNA) carries the genetic information and ribonucleic acid (RNA) is involved in putting this information to work in the cell. They differ in three ways.

1. The sugar in RNA is ribose while the sugar in DNA is 2-deoxyribose.
2. Four different bases are found in DNA cytosine (C), thymine (T), adenine (A) and guanine (G). In RNA, thymine does not occur and its place is taken by uracil (U).
3. DNA is nearly always double stranded, while RNA is usually single stranded.

The key to the ability of DNA to preserve genetic information and to pass it on from generation to generation is its double-stranded structure, first deduced by James Watson and Francis Crick in 1953. This was the discovery that initiated the field of molecular biology. Watson and Crick noticed that the double stranded structure provides a mechanism whereby the genetic information can be duplicated. This process is called replication. The synthesis of a polypeptide (protein) involves a series of events which occur in accordance with the information contained in the DNA.

## KEY POINTS

1. Macromolecules are large molecules built up from small units called monomers.
2. The organic macromolecules are biological and non-biological in nature.
3. Biological macromolecules are called life molecules and non-biological are manmade synthetic polymers.
4. The polymer chains may be linear, branched or cross-linked.
5. A thermoplastic polymer is one which can be softened and hardened by heating and cooling respectively.
6. A thermosetting polymer is one which becomes permanently hard on heating.
7. The polymerization process involves addition and condensation reactions.
8. The formation of polyethene is an example of addition polymerization.
9. Nylon, a polyamide and terylene, a polyester, are examples of condensation polymers.
10. Carbohydrates, proteins, fats, and nucleic acids are natural macromolecules.
11. Carbohydrates are the most abundant biomolecules on earth. They are classified into monosaccharides, oligosaccharides and polysaccharides.
12. Proteins are the essential components of all living organisms. They are the polymers of amino acids.
13. Lipids are naturally occurring organic compounds of animal and plant origin and they are soluble in organic solvents. Fats and oils are the most important lipids found in nature.
14. Enzymes are proteins that catalyze chemical reactions in living organisms. They are very specific in their action.

## EXERCISE

### Q.1 Fill in the blanks

1. Macromolecules are built up from small units called \_\_\_\_\_.
2. Nylon is a polyamide and terylene is a \_\_\_\_\_.
3. Nylon is prepared by the reaction of \_\_\_\_\_ and hexamethylene diamine.
4. Based on their thermal properties, plastics are divided into \_\_\_\_\_ main classes.
5. Polyvinyl chloride is a \_\_\_\_\_ plastic.
6. Glucose is stored as \_\_\_\_\_ in the liver.
7. Glucose and fructose are water \_\_\_\_\_ carbohydrates.
8. Protein after digestion changes to \_\_\_\_\_.
9. Purine and pyrimidine are \_\_\_\_\_ of nucleic acids.
10. Addition of a plasticizer \_\_\_\_\_ the flexibility of the polymer.

### Q.2 Indicate True or False.

1. Nylon 6,6 and terylene are condensation polymers.
2. The disposal of plastics does not cause any pollution problem.

3. Fructose is a polysaccharide carbohydrate.
4. Human beings get no food nutrient from cellulose.
5. The most abundant and the most important steroid in the human body is vitamin D.
6. Enzymes are the compounds containing C, H and O only.
7. The degree of unsaturation of fats is measured by their iodine number.
8. Activity of an enzyme varies with temperature and pH.
9. Nucleic acids are biological catalysts.
10. The nucleic acids are responsible for protein synthesis in the human body.

**Q.3. Multiple choice questions. Encircle the correct answer.**

- (i) In which of these processes are small organic molecules made into macromolecules?
  - (a) the cracking of petroleum fractions
  - (b) the fractional distillation of crude oil
  - (c) the polymerization of ethene
  - (d) the hydrolysis of proteins
- (ii) Which of these polymers is an addition polymer?
  - (a) nylon-6,6
  - (b) polystyrene
  - (c) terylene
  - (d) epoxy resin
- (iii) Which of these polymers is a synthetic polymer?
  - (a) animal fat
  - (b) starch
  - (c) cellulose
  - (d) polyester
- (iv) Plastics are a pollution problem because many plastics:
  - (a) are made from petroleum
  - (b) are very inflammable
  - (c) burn to produce toxic fumes
  - (d) decompose to produce toxic products
- (v) The fibre which is made from acrylonitrile as monomer:
  - (a) PVC
  - (b) rayon fibre
  - (c) acrylic fibre
  - (d) polyester fibre
- (vi) A polymeric substance that is formed in the liquid state and then hardened to a rigid solid is called a:
  - (a) fibre
  - (b) plastic
  - (c) varnish
  - (d) polyamide resin
- (vii) Vegetable oils are:
  - (a) unsaturated fatty acids
  - (b) glycerides of unsaturated fatty acids
  - (c) glycerides of saturated fatty acids
  - (d) essential oils obtained from plants
- (viii) Which one of the following elements is not present in all proteins?
  - (a) carbon
  - (b) hydrogen
  - (c) nitrogen
  - (d) sulphur

- (ix) Which one of the following nitrogenous bases is not present in RNA:  
(a) cytosine (b) adenine (c) thiamine (d) uracil
- (x) Which one of the following enzymes brings about the hydrolysis of fats?  
(a) urease (b) maltase (c) zymase (d) lipase
- (xi) The reaction between fat and NaOH is called:  
(a) esterification (b) hydrogenolysis  
(c) fermentation (d) saponification
- (xii) Which one of the following statements about glucose and sucrose is incorrect?  
(a) both are soluble in water (b) both are naturally occurring  
(c) both are carbohydrates (d) both are disaccharides
- Q.4** Explain the following terms:  
(a) Addition polymer (b) Condensation polymer  
(c) Thermoplastic (d) Thermosetting plastic
- Q.5** Write notes on:  
(a) Polyester resins (b) Polyamide resins (c) Epoxy resins
- Q.6** What is the repeating unit in each of the following polymers?  
(a) polystyrene (b) nylon 6,6 (c) teflon (d) orlon
- Q.7** What are carbohydrates and how are they classified?
- Q.8** Point out one difference between the compounds in each of the following pairs.  
(a) Glucose and fructose  
(b) Sucrose and maltose  
(c) Cellulose and starch
- Q.9** What are lipids? In what way fats and oils are different?
- Q.10** Define saponification number and iodine number. Discuss the term rancidity.
- Q.11** What is the difference between a glycoside linkage and a peptide linkage?
- Q.12** What is the chemical nature of enzymes? Discuss the classification of enzymes.
- Q.13** What are nucleic acids? Write down the role of DNA and RNA in life.

## CHAPTER

## 15

**COMMON CHEMICAL INDUSTRIES  
IN PAKISTAN**

In this chapter you will learn

A brief description of the processes alongwith flow sheet diagrams and the reactions involved in the important industries like fertilizers, cement and paper.

**15.1 INTRODUCTION**

Pakistan had an almost negligible industrial base at the time of its creation in 1947. For the past 55 years the country has undergone a structural change from a purely agrarian economy to a semi-chemical industrial state. Pakistan has developed most of the consumer goods industries. Heavy industries like iron, fertilizer, cement and paper are also on the road to development. The natural resources are being exhausted with growing population and increase in the standard of living all over the world. To meet this situation the scientists and technologists are busy in the development of the substitute materials from cheaper and reusable sources, e.g., the natural fibres like cotton, silk, wool cannot meet the clothing requirements of the world, therefore, scientists have developed the artificial fibres. Similarly, crop yield has been increased by the development of the fertilizers, pesticides and herbicides to meet the world food requirements. All these materials require their chemical preparation on industrial scales. In fact the magnitude of chemical industry of a country is a measure of its economic development and progress. Different chemical industries such as fertilizer, cement and paper are developing very fast in Pakistan.

**15.2 FERTILIZERS****15.2.1 Early History**

Agriculture has been one of the oldest industry known to man. The use of manure as a fertilizer dates back to the beginning of agriculture. Since 5000 B.C, the Chinese have been using animal manure in their fields. A manure is an organic material used to fertilize land and it usually consists of faeces and urine of domestic livestock.

The first prerequisite to the use of fertilizers was an understanding of the function of plant nutrients in plant growth. Compounds of these elements namely nitrogen, phosphorus and

potassium are considered to be the most important nutrients essential for plant growth. The elements, like sulphur, magnesium and calcium are considered of secondary importance.

### 15.2.2 What are Fertilizers?

Fertilizers are the substances added to the soil to make up the deficiency of essential elements like nitrogen, phosphorus and potassium (NPK) required for the proper growth of plants. Fertilizers enhance the natural fertility of the soil or replenish the chemical elements taken up from soil by the previous crops.

## 15.3 ELEMENTS ESSENTIAL FOR PLANT GROWTH

Plants need nutrients from the soil for a healthy growth. The elements essential for the plant growth can be classified as micro-nutrients and macro-nutrients.

### 15.3.1 Micro-nutrients (Trace elements)

The nutrients which are required in a very small amount for the growth of plant, are called micro-nutrients. These include Boron, Copper, Iron, Manganese, Zinc, Molybdenum and Chlorine. Only minute amounts of these elements are needed for healthy plant growth and it may be dangerous to add too much quantity because they are poisonous in larger quantities. These are generally required in quantities ranging from 6 grams to 200 grams per acre.

### 15.3.2 Macro-nutrients

The nutrients which are required in a large amount for the growth of plants, are called macro-nutrients. These include Nitrogen, Phosphorus, Potassium, Calcium, Magnesium, Sulphur, Carbon, Hydrogen and Oxygen. These are generally required in quantities ranging from 5 kg to 200 kg per acre.

### 15.3.3 Requirement of a Fertilizer

Every compound of the desired elements cannot be a fertilizer. The desired elements should be present in the compound in a water soluble form (so that the plant can take it up) readily available to the plants. The compound employed as fertilizer should be stable in soil as well as in storage, e.g., it should not be deliquescent or set to hard stony materials with time. Above all it should be cheap to manufacture.

### 15.3.4 Essential Qualities of a Good Fertilizer

The essential requisites of a good fertilizer are:

1. The nutrient elements present in it must be readily available to the plant.
2. It must be fairly soluble in water so that it thoroughly mixes with the soil.
3. It should not be injurious to plant.
4. It should be cheap.
5. It must be stable so that it is available for a longer time to the growing plant.
6. It should not alter the pH of the soil.
7. By rain or water, it should be converted into a form, which the plant can assimilate easily.

## 15.4 CLASSIFICATION OF FERTILIZERS

Fertilizers are classified according to the nature of the elements like nitrogen, phosphorus and potassium which they provide to the soil. This classification gives the following types of fertilizers.

- i) Nitrogenous fertilizers
- ii) Phosphatic fertilizers
- iii) Potassium fertilizers

### 15.4.1 Nitrogenous Fertilizers

These fertilizers supply nitrogen to the plants or soil. Nitrogen is required during the early stage of plant growth for the development of stems and leaves. It is the main constituent of protein, imparts green colour to the leaves and enhances the yield and quality of the plants. Some of the examples of nitrogen fertilizers are: - ammonium sulphate, calcium ammonium nitrate, basic calcium nitrate, calcium cyanamide, ammonia, ammonium nitrate, ammonium phosphate, ammonium chloride and urea.

#### (i) Ammonia (NH<sub>3</sub>) as a Fertilizer

Ammonia is used in liquid state while all the other fertilizers are used in the solid form. All the nitrogen fertilizers except calcium nitrate, sodium nitrate and potassium nitrate make the soil acidic but this acidity can easily be controlled through liming of the soil (by the addition of lime) at regular intervals. liquid ammonia has become an important fertilizer for direct application to soil. It contains 82% nitrogen and it is injected about 6 inches under the surface of soil to avoid it from seeping out.

#### (ii) Urea (NH<sub>2</sub>-CO-NH<sub>2</sub>)

Urea is a high quality nitrogenous fertilizer. It contains about 46% nitrogen and is the most concentrated solid nitrogen fertilizer. It is the most widely used nitrogen fertilizer in Pakistan.

#### Manufacturing Process

Urea is produced by the reaction of liquid ammonia with gaseous carbon dioxide.

Following steps are involved in the manufacture of urea.

- i) Preparation of Hydrogen and Carbon dioxide
- ii) Preparation of Ammonia
- iii) Preparation of Ammonium Carbamate
- iv) Preparation of Urea
- v) Concentration of Urea
- vi) Prilling

#### Preparation of Ammonium Carbamate

Gaseous CO<sub>2</sub> is mixed with ammonia in the volume ratio of 1:2 in a reactor to produce ammonium carbamate.



## Preparation of Urea

Dehydration of ammonium carbamate gives urea.

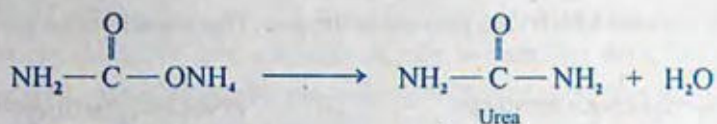

## Concentration of Urea Solution

The urea solution is concentrated in an evaporation section where water is evaporated by heating with steam under vacuum in two evaporation stages whereby 99.7% urea melt is obtained. It is then pumped to prilling tower.

## Prilling

The molten urea is sprayed at the prilling tower by means of prilling bucket where it is cooled by the air rising upward. Molten droplets solidify into the form of prills. Urea prills thus produced are either sent to the bagging section or to the bulk storage, Fig. 15.1.

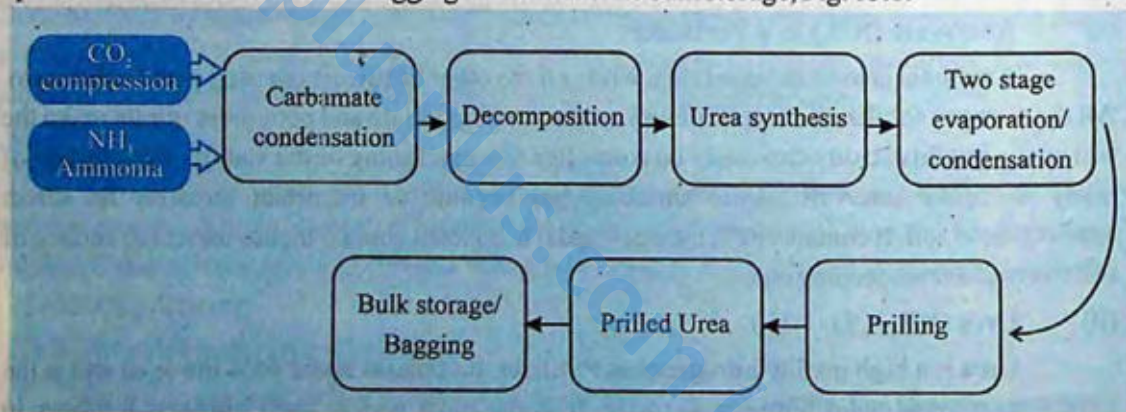

Fig. 15.1: Flow sheet diagram for manufacture of urea

### (iii) Ammonium Nitrate (NH<sub>4</sub>NO<sub>3</sub>)

It is manufactured by the neutralization reaction between ammonia and nitric acid as given below.



After neutralization, the water is evaporated. The solid ammonium nitrate is melted and then sprayed down from a tall tower. The falling droplets are dried by an upward current of air. The fertilizer solidifies as tiny, hard pellets called prills. Prills of fertilizers are free of dust, easy to handle and easy to spread on the field. Ammonium nitrate contains 33 – 33.5% nitrogen. It is a useful fertilizer for many crops except paddy rice because the microbial bacteria in flooded fields decompose it to nitrogen gas. It is also used in combination with limestone. It is hygroscopic in nature.

## 15.4.2 Phosphatic Fertilizers

These fertilizers provide phosphorus to the plants or soil. Phosphorus is required to

stimulate early growth, to accelerate the seed and fruit formation during the later stages of growth. It also increases resistance to diseases. The various phosphatic fertilizers have different compositions, due to which they have different solubilities. The two most important water soluble fertilizers are super phosphate (calcium super phosphate)  $\text{Ca}(\text{H}_2\text{PO}_4)_2$  and triple phosphate (diammonium-phosphate)  $(\text{NH}_4)_2\text{HPO}_4$ .

(i) **Diammonium Phosphate  $(\text{NH}_4)_2\text{HPO}_4$**

This compound of fairly high purity is prepared by continuous process that consists of reacting anhydrous ammonia gas and pure phosphoric acid at  $60 - 70^\circ\text{C}$  and pH 5.8 - 6.0.



It is an exothermic reaction. The heat of reaction vaporizes water from the liquor and the crystals of diammonium phosphate are taken out, centrifuged, washed and dried. It contains 16% nitrogen and 48%  $\text{P}_2\text{O}_5$ . This product contains about 75% plant nutrients and is deemed suitable for use either alone or in mixed with other fertilizers.

### 15.4.3 Potassium Fertilizers

These fertilizers provide potassium to the plant or soil. Potassium is required for the formation of starch, sugar and the fibrous material of the plant. They increase resistance to diseases and make the plants strong by helping in healthy root development. They also help in ripening of seeds, fruits and cereals. Potassium fertilizers are especially useful for tobacco, coffee, potato and corn.

(i) **Potassium Nitrate  $(\text{KNO}_3)$**

On industrial scale, it is prepared by the double decomposition reaction between sodium nitrate and potassium chloride.



A concentrated hot solution of sodium nitrate is prepared and solid potassium chloride is added into it. On heating, the potassium chloride crystals change into sodium chloride crystals, and the hot potassium nitrate is run through the sodium chloride crystals at the bottom of the kettle. A little water is added to prevent further deposition of sodium chloride as the solution is cooled, which results into a good yield of pale yellow solid potassium nitrate. It contains 13% nitrogen and 44% potash.

### 15.4.4 Fertilizer Industry in Pakistan

Pakistan is essentially an agricultural country. In order to keep up the production of agricultural commodities and to compensate for the depletion of nutrients which get exhausted by repeated cultivation, the urea fertilizer has gained importance. For a developing country like Pakistan, there is an ever-growing demand for urea fertilizer. Government of Pakistan is trying its utmost to narrow the gap between supply and demand of fertilizers. Consistent efforts have been made to instal fertilizer manufacturing plants. At present, there are about 14 fertilizer plants in private as well as public sectors in the country which are manufacturing different types of

fertilizers. The total production of urea fertilizer in 2002 in Pakistan is about 56,30,100 metric tons/ annum

## 15.5 CEMENT

### 15.5.1 Early History

Cement is a very important building material which was first introduced by an English Mason Joseph Aspdin. He found it when strongly heated mixture of limestone and clay was mixed with water and allowed to stand, it hardened to a stone like mass which resembled Portland rock; a famous building stone of England. Since then the name of **Portland Cement** is given to the mixture of lime (obtained from limestone), silica, iron oxide and alumina. This was the start of Portland cement industry, as we know today. The cement is now low in cost, as it is applied everywhere in the construction of houses, public buildings, roads, industrial plants, dams, bridges and many other structures.

### 15.5.2 Definition

Cement is the material obtained by burning an intimate mixture of calcareous and argillaceous materials at sufficiently high temperature to produce clinkers. These clinkers are then ground to a fine powder. The essential constituents are lime (obtained from limestone) silica and alumina (present in clay).

### 15.5.3 Raw Materials

The important raw materials used for the manufacture of cement are:

1. Calcareous material (limestone, marble, chalks, marine shell) as source of CaO.
2. Argillaceous material (clay, shale, slate, blast furnace slag). They provide acidic components such as aluminates and silicates,
3. Other raw material being used is gypsum.

### 15.5.4 Manufacturing Process of Cement

The manufacturing process of cement involves either a dry process or a wet process. The choice of dry or wet process depends on the following factors.

1. Physical condition of the raw materials.
2. Local climatic conditions of the factory.
3. The price of the fuel.

In Pakistan most of the factories use wet process for the production of cement. Dry process needs excessive fine grinding and it is more suited for the hard material, Wet process, on the other hand, is free from dust, grinding is easier and the composition of the cement can easily be controlled.

Compound	%age
Lime (CaO)	62
Silica (SiO <sub>2</sub> )	22
Alumina (Al <sub>2</sub> O <sub>3</sub> )	7.5
Magnesia (MgO)	2.5
Iron oxide (Fe <sub>2</sub> O <sub>3</sub> )	2.5
Sulphur trioxide (SO <sub>3</sub> )	1.5
Sodium oxide (Na <sub>2</sub> O)	1.0
Potassium oxide (K <sub>2</sub> O)	1.0

### 15.5.5 Wet Process

In this process grinding is done in the presence of water. There are five stages in the manufacture of Portland cement, Fig. 15.2.

1. Crushing and grinding of the raw material.
2. Mixing the material in correct proportion.
3. Heating the prepared mixture in a rotary kiln.
4. Grinding the heated product known as clinker.
5. Mixing and grinding of cement clinker with gypsum.

#### 1. **Crushing and Grinding**

Soft raw materials are first crushed into a suitable size, often in two stages, and then ground in the presence of water, usually in rotating cylindrical ball or tube mills containing a charge of steel balls.

#### 2. **Mixing of Raw Material**

The powdered limestone is then mixed with the clay paste in proper proportion (limestone 75%, clay 25%); the mixture is finely ground and made homogeneous by means of compressed air mixing arrangement. The resulting material is known as slurry. The slurry, which contains 35 to 45% water, is sometimes filtered to reduce the water content from 20 to 30% and the filler cakes are stored in storage bins. This reduces the fuel consumption for heating stage.

#### 3. **Heating the Slurry in a Rotary Kiln**

Raw meal or slurry prepared as above is introduced into the rotary kiln with the help of a conveyer. The rotary kiln consists of a large cylinder 8 to 15 feet in diameter and 300 – 500 feet in length. It is made of steel and is lined inside with firebricks. The kiln rotates horizontally on its axis at the rate of 1 – 2 revolution per minute and it is inclined a few degree. As the kiln rotates, the charge slowly moves downward due to the rotary motion. Now the charge is heated by burning coal, oil or natural gas. In the rotary kiln the charge passes through the different zones of temperature where different reactions take place. The charge takes 2-3 hours to complete the journey in the kiln.

##### (a) **Drying or Pre-heating Zone (Minimum temperature zone)**

In this zone the temperature is kept at 500°C, whereby the moisture is removed and the clay is broken into  $Al_2O_3$ ,  $SiO_2$ , and  $Fe_2O_3$ .

##### (b) **Decomposition Zone (Moderate temperature zone)**

Here the temperature goes upto 900°C In this zone the limestone ( $CaCO_3$ ) decomposes into lime ( $CaO$ ) and  $CO_2$ .

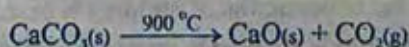

##### (c) **Burning Zone (Maximum temperature zone)**

In this zone, the temperature goes up to 1500°C and the oxides, e.g.,  $CaO$ ,  $SiO_2$ ,  $Al_2O_3$  and  $Fe_2O_3$  combine together and form calcium silicate, calcium aluminate and calcium ferrite.

**(d) Cooling Zone**

This is the last stage in the kiln where the charge is cooled up to 150-200°C.

**(iv) Clinker Formation**

The resulting product obtained from the kiln is known as cement clinker. This has the appearance of greenish black or grey coloured balls varying in size from small nuts to peas.

**(v) Grinding the Clinkers with Gypsum**

The cement clinkers are then air-cooled. The required amount of gypsum (2.0%) is first ground to a fine powder and then mixed with clinkers. At this stage finished cement is pumped pneumatically to storage silos from where it is drawn for packing in paper bags or for dispatch in bulk containers.

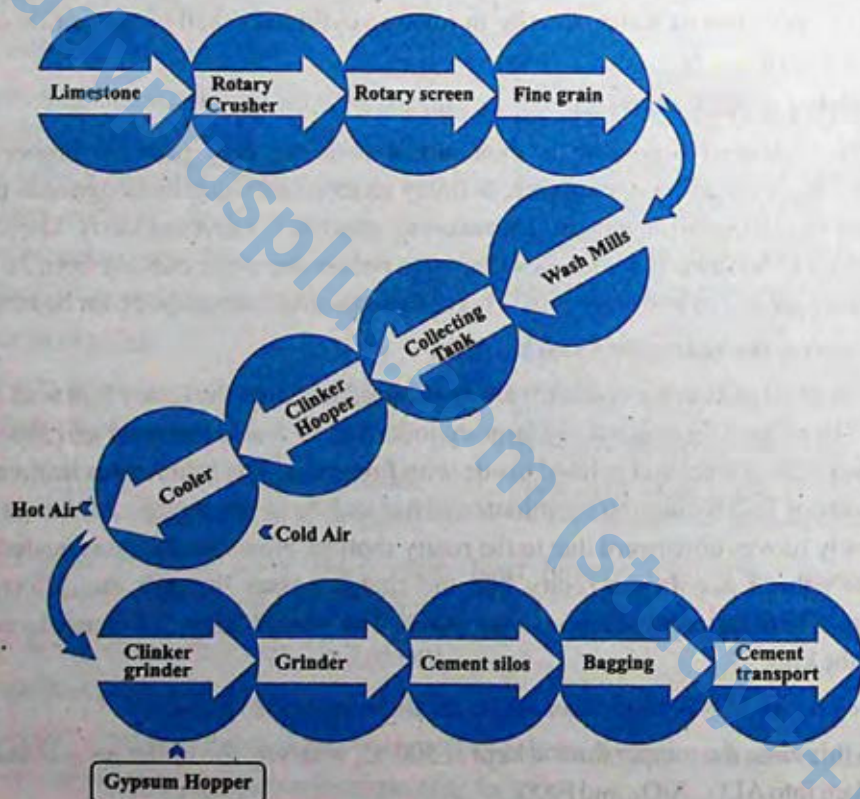

Fig. 15.2: Flow sheet diagram for the manufacture of cement

### 15.5.6 Setting of Cement

The use of cement in the construction of building is based on its property of setting to a hard mass when its paste with water is allowed to stand for sometime. The reactions involved in the setting of cement are described as follows:

**(i) Reactions Taking Place in First 24 Hours**

A short time after the cement is mixed with water, tri-calcium aluminate absorbs water

(hydration) and forms a colloidal gel of the composition,  $3\text{Ca}\cdot\text{Al}_2\text{O}_3\cdot 6\text{H}_2\text{O}$ , (hydrated tricalcium aluminate). This gel starts crystallizing slowly, reacts with gypsum ( $\text{CaSO}_4\cdot 2\text{H}_2\text{O}$ ) to form the crystals of calcium sulpho-aluminate ( $3\text{CaO}\cdot\text{Al}_2\text{O}_3\cdot 3\text{CaSO}_4\cdot 2\text{H}_2\text{O}$ ).

### (ii) Reactions Taking Place Between 1 to 7 Days

Tricalcium silicate ( $3\text{CaO}\cdot\text{SiO}_2$ ) and tri-calcium aluminate ( $3\text{CaO}\cdot\text{Al}_2\text{O}_3$ ) get hydrolyzed to produce calcium hydroxide and aluminium hydroxide. The calcium hydroxide, thus formed, starts changing into needle-shaped crystals, which get studded in the colloidal gel and impart strength to it. Aluminium hydroxide, on the other hand, fills the interstices resulting in hardening the mass. The gel formed starts losing water partly by evaporation and sets to a hard mass.

### 15.5.7 Cement industry in Pakistan

At the time of partition in 1947, there were four cement plants in West Pakistan, which produced about 330,000 tons of cement every year. However, in 1954 the production of cement went up to 660,000 tons. In 1956 two more cement factories were set up at Daud Khel and Hyderabad, but even then the production of cement was not enough to meet the increasing demand of the construction industry in the country.

For a developing country like Pakistan there is always an increasing need of cement for development projects. Efforts were thus made to build more factories. At present there are about 22 cement factories in private as well as in public sectors, which are manufacturing cement both by dry and wet processes. The total production of these 22 cement plants is 9,578,802 metric tons/annum.

## 15.6 PAPER INDUSTRY

### 15.6.1 Early History

The word paper is derived from the name of a reedy plant Papyrus, which grew abundantly along the marshy delta of the River Nile in Egypt around 3000 B.C. The invention of modern paper is credited to Ts'ai Lun of China, who, in 105 A.D, was an official attached to the Imperial Court of China. He prepared a sheet of paper using the bark of mulberry tree that was treated with lime and mixed with bamboo and other fibres to get the paper of desired properties.

### 15.6.2 Definition

Paper is defined in term of its method of production, that is a sheet material made up of a network of natural cellulosic fibres which have been deposited from an aqueous suspension. The product obtained is a network of interwinning fibres.

### 15.6.3 Brief Description of the Process.

#### Raw Material

The main raw materials used in the production of pulp and paper in Pakistan is of two types, that is non-woody and woody raw materials.

Nonwoody Raw Materials		Woody Ras Material
(i) Wheat straw	(v) Cotton stalk	(i) Popler (hard wood)
(ii) Rice straw	(vii) Cotton linter	(ii) Eucalyptus (hard wood)
(iii) Bagasse	(viii) Kahi grass	(iii) Douglas fir (soft wood)
(iv) Bamboo	(ix) Grasses	
(v) Rag		

### 15.6.4 Pulping Processes

The following are three principal methods of chemical pulping and are used for the production of paper pulps.

1. Kraft process (Alkaline)
2. Sulphite process (Acidic)
3. Neutral sulphite semi-chemical process (NSSC)

The neutral sulphite semi chemical process has come to occupy the dominant position because of the advantages in chemical recovery and pulp strength. In this section, we will discuss only the neutral sulphite semi chemical process, which is mostly used in pulp and paper industry in Pakistan.

### 15.6.5 Neutral Sulphite Semi Chemical Process

#### Process Description

This process utilizes sodium sulphite cooking liquor which is buffered with sodium carbonate or NaOH to neutralize the organic acid liberated from the raw materials. The non-woody raw materials which are used in this process are wheat straw, rice straw, bagasse, cotton linter and rags. Wheat straw may be used alone or combined with other materials in different proportions. The essential steps in the process are as follows Fig. 15.3.

- |                                 |                            |
|---------------------------------|----------------------------|
| i. Cutting of the raw materials | ii. Dry cleaning           |
| iii. Wet cleaning               | iv. Screening              |
| v. Digestion                    | vi. Blow tank              |
| vii. Pulp washing               | viii. Bleaching            |
| ix. Paper making machine        | x. Stock preparation plant |

#### (i) Cutting of Raw Materials

The non-woody raw materials come in the pre-cut state and are processed as such. But in the case of wood based raw materials, big logs are cut into small chips before further processing.

#### (ii) Dry Cleaning

Wheat straw is collected from the storage and is then sent for dry cleaning. For this purpose air is blown into the raw material, which removes unwanted particles.

**(iii) Wet Cleaning**

Dry wheat straw is then subjected to wet cleaning, which not only removes the remaining dust particles, but the soluble materials also get dissolved in water.

**(iv) Screening**

In most pulp and paper processes some type of screening operation is required to remove the oversized troublesome and unwanted particles. Magnetic separator removes iron pieces like nails and bolts, etc. Stones and other oversized pieces are removed by centricleaners. The major types of chest screens are vibratory, gravity, and centrifugal. The material is then sent to wet silo.

**(v) Digestion**

From wet silo, the material is sent to digester. The digester is usually 10 meters in length and 2 meters in diameter. It is made of steel and wrought iron. This is the main unit of the process. The digestion process can be either batch or continuous. In our country batch process is mostly used.

As the raw material enters into the digester, steam is introduced at the bottom and a liquor containing sodium sulphite is injected simultaneously to cover the raw material. Sodium sulphite used is buffered with sodium carbonate or sodium hydroxide to maintain its pH 7-9. The digester is closed carefully. It is revolved at 2.5 RPM and a temperature of 160- 180°C is maintained. The digester takes 45 minutes to attain the desired temperature after which it gets switched off automatically and pressure is released.

**(vi) Blow Tank**

The cooked material from the digester is blown into a blow tank and then pumped to a centrifugal screen for the separation of cooked from uncooked materials.

**(vii) Pulp Washing**

The cooked material from the blow tank is washed thoroughly with water using 80-mesh sieve to remove the black liquor that would contaminate the pulp during subsequent processing steps. The pulp is washed with required amount of water to remove soluble lignin and coloured compounds. Lignin is an aromatic polymer and causes paper to become brittle. It is then thickened and finally stored in high-density storage tower.

**(viii) Bleaching**

The pulps obtained from chemical pulping are brown in colour and are unsuitable for printing and writing papers which require a bright white pulp. The colour of these pulps is mainly due to residual lignin. These pulps are then sent to bleaching unit.

In Pakistan, bleaching is done with chlorine dioxide or sodium hypochlorite and hydrogen peroxide. After washing, the unbleached pulp is sent to the chlorinator where chlorine at 4 - 5 bar pressure is injected from chlorine tank. The chlorine react with unbleached pulp at about 45°C for 45-60 minutes to give the good results. The residual chlorine is neutralized with water which act as antichlor. The correct dosage is important and calculated amount of chlorine is needed to

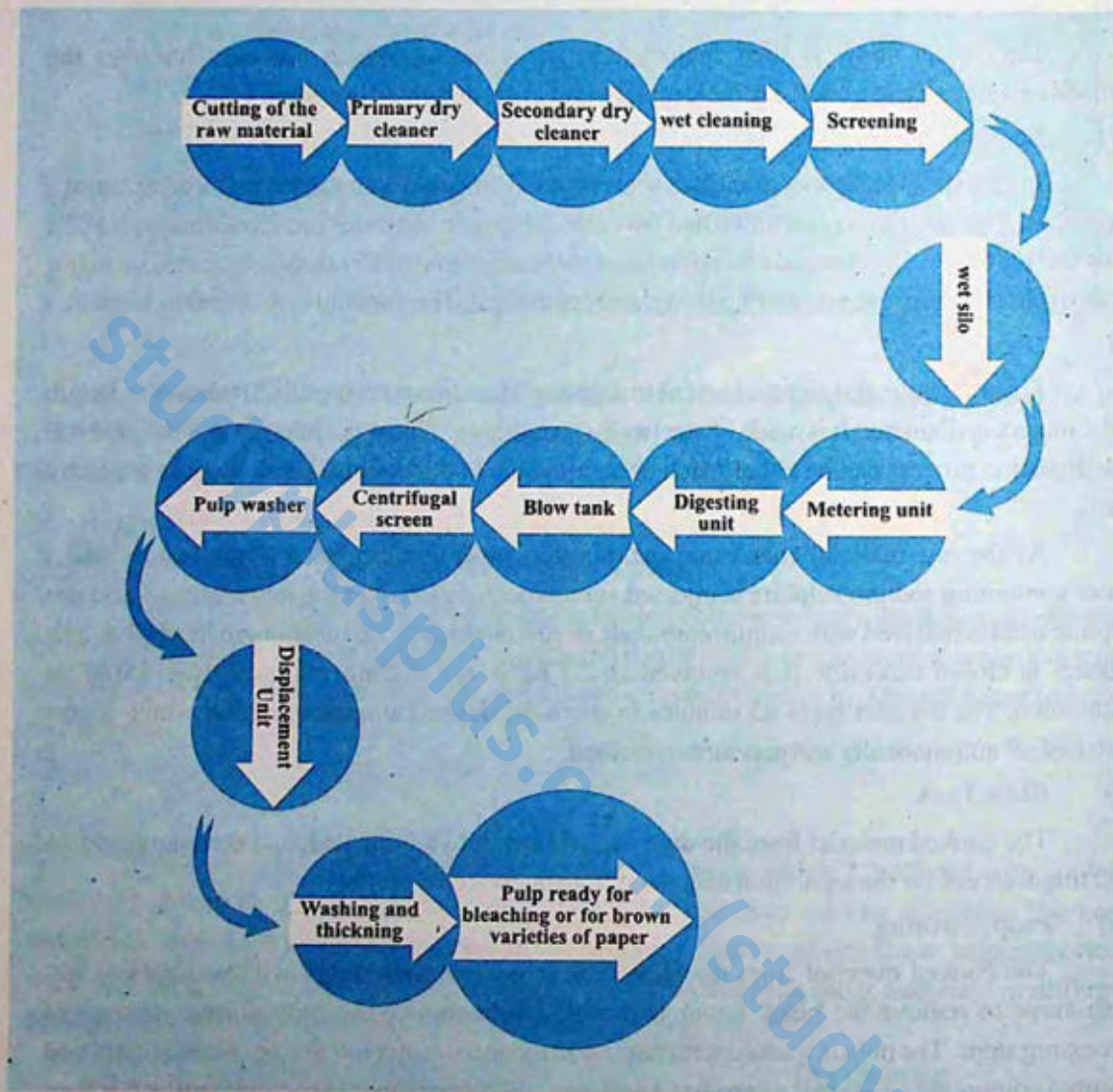

Fig. 15.3: Flow sheet diagram for neutral sulphite semi-chemical process

achieve the required brightness. After chlorination pulp is washed with hot water at  $60^{\circ}\text{C}$  and is then sent to the storage tank. Pulp is dried with hot air supply. After drying the pulp is ready for manufacturing of paper.

#### (ix) Stock Preparation Plant

There are three important stages in the treatment of the pulp prior to its delivery to the paper making machine. The first is the dispersion of the pulp as a slurry in water, the second is the mechanical refining or beating of the fibres to develop appropriate physical and mechanical properties for the product being made and the third is the addition of chemical additives and recycled fibres from the waste paper plant. Wet end chemistry of paper start from here.

**(x) Paper Making Machine**

A basic Fourdrinier type machine is used for paper making and a brief description of its major components is given below Fig. 15.4.

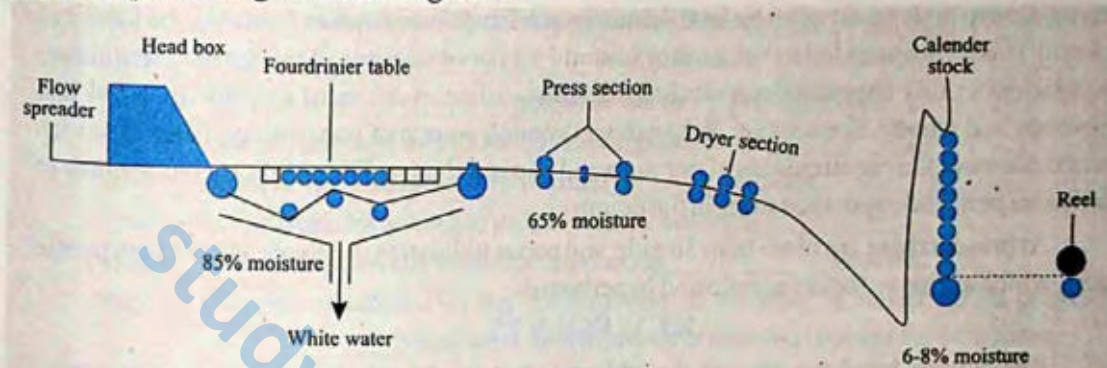

Fig. 15.4 Fourdrinier paper making machine

**(a) Flow Spreader**

The flow of spreader takes the pulp and distributes it evenly across the machine from back to front. Consistency of the stock is below 1%.

**(b) Head Box**

The pressurized head box discharges a uniform jet of pulp suspension on a fabric where special suction devices work for the removal of water.

**(c) Fourdrinier Table**

The endless, moving fourdrinier fabric forms the fibre into a continuous matted web while the fourdrinier table drains the water by suction forces.

**(d) Press Section**

The paper sheet is conveyed through a series of roll presses where additional water is removed and the web structure is consolidated (i.e., the fibres are forced into intimate contact).

**(e) Dryer Section**

Wet sheet of paper so formed is dried in the dryer section of the machine with the help of rotary drum. Water is separated from the fibre either by gravity, by suction or by pressing and by heating.

**(f) Calendar Stock**

The sheet is calendered through a series of roll nips to reduce thickness and smooth the surface.

**(g) Reel**

The dried paper is wound in the form of a reel having final moisture of about 6-8%.

**15.6.6 Paper Industry in Pakistan**

Paper plays such an important role in the present day economic development that its consumption is taken as an index of a country's progress and prosperity. There was no pulp and paper industry in Pakistan at the time of independence in 1947. The country consumed about

25000 tons of pulp and paper products per year and all of these were imported from abroad at a cost of 25 million rupees. The start of the paper industry in our country was very slow because of various reasons, amongst the major ones being the non-availability of suitable fibrous raw material. Due to high prices of paper in Pakistan its per head consumption is among the lowest in the world. Paper consumption in Pakistan is around 5 kg per person per year. To make our country self-sufficient in this important commodity, we must utilize every source of raw material like non-woody and woody. Fortunately, Pakistan has enough source of non-woody material, which in future can meet the requirements of our pulp and paper industry. The efforts are being made to install more pulp and paper industries in the country.

At present there are more than 30 pulp and paper industries in private as well as in public sectors, which are manufacturing pulp and paperboard.

### KEY POINTS

1. Agriculture has been one of the oldest industries known to man. Since 5000 B.C. Chinese have been using animal manure in their fields.
2. Fertilizer is the natural or artificial substance containing the chemical elements that improve growth and productiveness of plants.
3. Natural fertilizers are materials derived from plants and animals whereas artificial fertilizers consist of manufactured material like urea, super phosphate and ammonium nitrate, etc.
4. Synthetic fertilizers are mainly used for making up the immediate deficiency of essential nutrient elements needed in relatively large amount.
5. The nutrients required in a very small amount for growth of plants are called micronutrients and the nutrients which are required in a very large amount are called macro-nutrients.
6. Urea and ammonium nitrate are the major nitrogenous fertilizers whereas super phosphate and triple phosphate are important phosphatic fertilizers.
7. Cement is a very important building material which was first introduced in 1824 by an English mason Joseph Aspdin.
8. Cement is the material obtained by burning an intimate mixture of calcareous and argillaceous materials at sufficiently high temperature to produce clinkers which are subsequently ground to a fine powder. Wet process is generally used in the production of cement.
9. The use of cement for construction purposes is based on its property of setting to a hard mass when mixed with water.
10. Paper is a sheet material made up of a network of natural cellulosic fibres.
11. The neutral sulphite semi-chemical process is often used for the manufacturing of paper because of the advantages in the chemical recovery and pulp strength.
12. The prime objective of all pulp making steps is to separate fibres present in the straw from cementing material called lignin, which is a natural binder.

## EXERCISE

## Q. 1 Fill in the blanks with suitable words.

- (i) Fertilizers enhance the natural \_\_\_\_\_ of the soil.
- (ii) Micro-nutrients are required in quantity ranging from \_\_\_\_\_ per acre.
- (iii) Ammonia contains \_\_\_\_\_ % nitrogen.
- (iv) Manure is an \_\_\_\_\_ material used to fertilize land.
- (v) Cement was first introduced by an English mason \_\_\_\_\_.
- (vi) Phosphorus is required to stimulate \_\_\_\_\_ of plant.
- (vii) In Pakistan, bleaching of pulp is carried out with \_\_\_\_\_.
- (viii) Cement is generally manufactured using \_\_\_\_\_ process.
- (ix) The use of cement in the construction of building is based on its property of \_\_\_\_\_ when its paste with water is allowed to stand for sometime.
- (x) Lignin is an \_\_\_\_\_ polymer and causes paper to become brittle.

## Q. 2 Indicate True or False.

- (i) Potassium fertilizers are especially used for tobacco and corn.
- (ii) Ammonia is used in gaseous state while all other fertilizers are used in solid form.
- (iii) In wet process for the manufacture of cement, grinding of raw material is done in the presence of water.
- (iv) The total production of cement in Pakistan is 56, 30, 100 metric tons/annum.
- (v) In neutral sulphite semi-chemical process, sodium sulphite is used buffered with sodium carbonate.
- (vi) Lignin is an inorganic binder.
- (vii) Paper consumption in Pakistan is around 5kg per person per year.
- (viii) Urea contains 90% nitrogen.
- (ix) The temperature of the digester in paper industry should be around 160-180°C.
- (x) Potassium fertilizers increase the capability of plants to resist diseases.

## Q. 3 Multiple choice questions. Encircle the correct answer.

- (i) Which three elements are needed for the healthy growth of plants?  
(a) N,S,P (b) N,Ca,P (c) N,PK (d) N,K,C
- (ii) Which woody raw material is used for the manufacture of paper pulp?  
(a) Cotton (b) Bagasse (c) Poplar (d) Rice straw
- (iii) The nitrogen present in some fertilizers helps plants:  
(a) to fight against diseases (b) to produce fat  
(c) to undergo photosynthesis (d) to produce protein
- (iv) Phosphorus helps the growth of:  
(a) root (b) leave (c) stem (d) seed
- (v) Micro-nutrients are required in quantity ranging from:  
(a) 4-40g (b) 6-200g (c) 6-200kg (d) 4-40kg

- (vi) During the manufacturing process of cement the temperature of the decomposition zone goes up to:  
(a) 600°C (b) 900°C (c) 1000°C (d) 1200°C
- (vii) The word paper is derived from the name of which reedy plant?  
(a) Rose (b) Sun flower (c) Papyrus (d) Water Hyacinth
- (viii) Which is not a calcareous material?  
(a) lime (b) clay (c) marble (d) marine shell
- (ix) Through how many zones, does the charge pass in a rotary kiln?  
(a) 4 (b) 3 (c) 2 (d) 5
- (x) For which crop, ammonium nitrate fertilizer is not used?  
(a) cotton (b) wheat  
(c) sugar cane (d) paddy rice
- Q.4** What are phosphatic fertilizers. How are they prepared? Mention the role of phosphorus in the growth of plants.
- Q.5** (a) What are fertilizers? Why are they needed?  
(b) Discuss the classification of fertilizers and their uses.  
(c) How is urea manufactured in Pakistan? Describe in detail the process used.
- Q.6** (a) What are the prospects of fertilizer industry in Pakistan?  
(b) What are essential nutrient elements and why these are needed for plant growth?  
(c) Write down the essential qualities of a good fertilizer?
- Q.7** (a) Describe the composition of a good portland cement.  
(b) Discuss the wet process for the manufacturing of cement with the help of flow sheet diagram.  
(c) What do you understand by the term "setting of cement". Also discuss the reactions taking place in first 24 hours?
- Q.8** What are the essential non-woody raw materials used in the production of pulp and paper in Pakistan?
- Q.9** (a) What are the principal methods of chemical pulping used for the production of paper?  
(b) Describe the neutral sulphite semi-chemical process for the manufacturing of pulp and paper.
- Q.10** (a) What are the common bleaching agents used in paper industry in Pakistan? Briefly describe the bleaching process.  
(b) What are the prospects of paper industry in Pakistan?

## CHAPTER

## 16

## ENVIRONMENTAL CHEMISTRY

## In this chapter you will learn

1. The meaning of environmental pollution.
2. The sources of air pollutants like CO, SO<sub>2</sub>, oxides of nitrogen, etc.
3. Effects of polluted air on environment.
4. The causes of water pollution.
5. The preparation of potable water.
6. About the solid waste and its management like dumping and incineration, treatment of industrial waste and recycling of solid waste.

## 16.1 INTRODUCTION

Environmental chemistry deals with the chemicals and other pollutants in the environment. In this field of chemistry, we study the sources, reactions, transportation of the chemicals and other toxic substances especially created by human activity in the environment and their adverse effects on human beings. This branch of chemistry is interrelated with all other branches of science, i.e., biology, physics, medicine, agriculture, public health and sanitary engineering, etc.

## 16.1.1 Components of the Environment

The environment consists of the following components:

- |                   |                  |
|-------------------|------------------|
| (i) Atmosphere    | (ii) Hydrosphere |
| (iii) Lithosphere | (iv) Biosphere   |
- (i) Atmosphere

The layer of gases surrounding the earth is called atmosphere. It consists of various gases in different proportions, i.e., N<sub>2</sub> (78%), O<sub>2</sub> (21%), Ar (0.9%), CO<sub>2</sub> (0.03%) and trace amounts of H<sub>2</sub>, O<sub>3</sub>, CH<sub>4</sub>, CO, He, Ne, Kr and Xe. It also contains varying amounts of water vapours.

Its thickness is about 1000 km above the surface of the earth and half of its mass is concentrated in the lower 5.6 km. The gases in the atmosphere absorb most of the cosmic rays and the major portion of the harmful electromagnetic radiation coming from the sun. The absorption of these harmful radiation protects the life on the earth.

The gases present in the atmosphere are essential for sustaining life on earth i.e., O<sub>2</sub> is required for breathing, CO<sub>2</sub> is required for plant photosynthesis, N<sub>2</sub> is used by nitrogen fixing

bacteria and water vapours are responsible for sustaining various forms of life on the earth. Atmosphere also maintains the heat balance of the earth.

### (ii) Hydrosphere

The hydrosphere includes all water bodies, mainly oceans, rivers, streams, lakes, polar ice caps, glaciers and ground water reservoirs (water below earth surface). Oceans contain 97% of earth's water but because of high salt contents this water cannot be used for human consumption. The polar ice caps and glaciers consist of 2% of the earth's total water supply. Only 1% of the total earth's water resources are available as fresh water, i.e., surface water; river, lake, stream and ground water. The fresh water is being used by agriculture (69%), industry (23%) and for domestic purposes (8%).

### (iii) Lithosphere

It consists of rigid rocky crust of earth and extends to the depth of 100 km. The mantle and core are the heavy interior of the earth, making up most of the earth's mass. The 99.5 % mass of the lithosphere is made of 11 elements, which are oxygen (~ 46.60 %), Si (~27.72 %), Al (8.13 %), Fe (5.0 %), Ca (3.63 %), Na (2.83 %), K (2.59 %), Mg (2.09 %) and Ti, H<sub>2</sub> and P (total less than 1 %). The elements present in trace amounts (0.1 to 0.02 %) are C, Mn, S, Ba, Cl, Cr, F, Zr, Ni, Sr and V. These elements mostly occur in the form of minerals.

### (iv) Biosphere/Ecosphere

Biosphere is the region of earth capable of supporting life. It includes lower atmosphere, the oceans, rivers, lakes, soils and solid sediments that actively interchange materials with all types of living organisms, i.e., human beings, animals and plants. Ecosystem is a smaller unit of biosphere which consists of community of organisms and their interaction with environment, i.e., animals, plants and microorganisms which lie in a definite zone and depend on the physical factors such as soil, water, and air.

Any substance in the environment which adversely affects the human health, quality of life and the natural functioning of ecosystem, is known as **environmental pollutant**. With continuous rapid growth in population, urbanization, industrialization and transportation, environmental pollution is spreading in almost every city of the world. The quantity of pollutants affecting the environment have increased rapidly in the last half-century and they have adversely affected human health and eco-system.

## 16.2 TYPES OF POLLUTION

### 16.2.1 Air Pollution

The atmosphere is polluted when harmful substances which damage the environment, human health and quality of life are mixed in it. The main sources of air pollution are:

The waste products given out from chimneys of industrial units and exhaust of automobiles may contain gases such as sulphur dioxide, sulphur trioxide, nitrogen oxides, carbon monoxide, hydrocarbons, ammonia, compounds of fluorine and radioactive materials. These waste products are called primary pollutants. The primary pollutants in the atmosphere through various reactions produce secondary pollutants such as sulphuric acid, carbonic acid, hydrofluoric acid, peroxyacetyl-nitrate (PAN), ozone, aldehydes, ketones and

peroxybenzol. All these compounds are toxic and their concentration in the atmosphere must be controlled. The sources for some of the main primary air pollutants are described below:

### 1. Carbon Monoxide

It is a colourless, odourless and highly toxic gas. It is three times lighter than air. It is slightly soluble in water.

#### Sources

##### (a) Natural

Natural sources of carbon monoxide emission are volcanic eruption, natural gas emission and oxidation of methane in the atmosphere.

##### (b) Human Activities

Fuel burning in various types of transportation, i.e., motor vehicles, railways and aircraft is the major source (75%) of carbon monoxide in the atmosphere. Other sources of carbon monoxide emission are forest fires, combustion of fossil fuel and agricultural products. Carbon monoxide is also emitted from industries in which any type of fuel is burnt in air. These industries include iron and steel, petroleum, cement, brick kilns, paper and pulp, etc. Incomplete combustion and dissociation of CO<sub>2</sub> at high temperature also produces CO.

Carbon monoxide is highly poisonous gas and causes suffocation if inhaled. It binds blood haemoglobin more strongly than oxygen thus excluding oxygen from normal respiration. The CO poisoning can be reversed by giving high pressure oxygen. Exposure to high concentration of CO results in headache, fatigue, unconsciousness and eventually death (if such exposure is sustained for longer period).

### 2. Nitrogen Oxides (NO<sub>x</sub>)

The gases nitric oxide, NO and nitrogen dioxide, NO<sub>2</sub> are represented by NO.

#### Sources:

##### (a) Natural

Bacterial action produces NO, mainly NO

##### (b) Human Activities

Nitrogen oxides are generally produced by combustion of coal, oil, natural gas and gasoline. Both oxides result from the oxidation of nitrogenous compounds present in fossil fuel. The burning of fuel in the presence of air in internal combustion engine also produces NO.

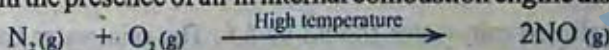

Nitrogen dioxide is produced when nitric oxide reacts with oxygen.



Residence time of NO and NO<sub>2</sub> in atmosphere are 4 and 3 days respectively. Due to photochemical reactions, NO<sub>x</sub> are converted to HNO<sub>3</sub>, which is carried down in rain fall or as dust.

### 3. Sulphur Oxides, SO<sub>2</sub>

#### Sources:

##### (a) Natural

On global scale most of sulphur dioxide is produced by volcanoes (67%) and by oxidation of sulphur containing gases produced by decomposition of organic matter.

**(b) Human Activities**

Air is polluted with  $\text{SO}_2$  due to combustion of coal (containing 1-9% S), crude oil and other fossil fuel in power plants and petroleum industry, etc.



These gases ( $\text{SO}_2$  and  $\text{SO}_3$ ) because of their pungent odour are very irritant and suffocating. Through various reactions in the atmosphere they form sulphate aerosols. These aerosols cause severe respiratory troubles particularly among older people. Sulphur dioxide is the major source of acid deposition in the atmosphere.

**4. Hydrocarbons****Sources****(a) Natural:**

Large quantities of hydrocarbons are emitted by different trees and plants in the atmosphere. Paddy fields produce a significant amount of methane in the atmosphere. Another natural source of methane is the anaerobic decomposition of organic matter by bacteria in water sediments and in soils. Methane has a mean residence time of about 3-7 years in the atmosphere.

**(b) Human Activities**

Automobiles are the major source of hydrocarbons emission. In addition to this, petroleum, coal, wood, incinerators, refuse burning and solvent evaporators also contribute towards the emission of hydrocarbons into the atmosphere.

**16.2.2 Effects of Polluted Air on Environment****1. Acid Rain**

Acid rain which nowadays is termed as acid deposition, was discovered by Angus Smith in Great Britain in the mid seventeenth century but this phenomenon gained importance as a serious environmental problem in 1950's. Initially it was referred to the precipitation which was more acidic than natural rain. Due to the presence of  $\text{CO}_2$  in the atmosphere, the natural rain itself forms carbonic acid:



The pH of unpolluted rain water should be 5.6. The rain water has pH less than 5 is considered truly acidic. In the atmosphere  $\text{SO}_2$  and  $\text{NO}_x$  are transformed by reactions with oxygen and water into  $\text{H}_2\text{SO}_4$  and  $\text{HNO}_3$  respectively. These acids get mixed with rain. The acid deposition includes both wet (rain, snow, fog) and dry acidic deposition.

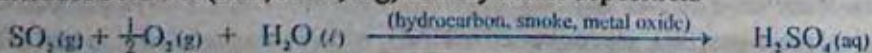

In some countries due to release of HCl by volcanic eruption there is temporary acid rain. Acidification of the soil and rocks can leach metals like aluminium, mercury, lead and calcium and discharges them into water bodies. These heavy metals are accumulated in fishes and are health hazards for humans and birds as they eat these fishes. The elevated concentration of aluminium is harmful for fish as it clogs the gills thus causing suffocation. Acidification of the soil can also leach nutrients thus damaging leaves and plants and growth of forest. It also

damages building materials such as steel, paint, plastic, cement, masonry work and sculptural materials especially of marble and limestone.

## 2. Smog

The word smog is a combination of smoke and fog. If it contains high contents of  $\text{SO}_2$ , it is chemically reducing in nature and is known as 'reducing smog'. The main cause of reducing smog is combustion of coal. Photochemical smog consists of higher concentrations of oxidants like ozone and is also termed as oxidizing smog, it is a yellowish brownish grey haze which is formed in the presence of water droplets and chemical reactions of pollutants in the air. It has unpleasant odour because of its gaseous components. The main reactants of photochemical smog are nitric oxide  $\text{NO}$  and unburnt hydrocarbons. Nitric oxide is oxidized to nitrogen dioxide within minutes to hours depending upon the concentration of pollutant gas. The yellow colour in photochemical smog is due to the presence of nitrogen dioxide.

The following conditions are required for the formation of smog:

1. There must be sufficient  $\text{NO}$ , hydrocarbons and volatile organic compounds (VOC) emitted by the vehicular traffic.
2. Sunlight, so that some of the chemical reactions may occur at a rapid rate.
3. The movement of air mass must be little so that reactions are not disturbed.

The overall result of photochemical smog is the built up of oxidizing agents such as  $\text{H}_2\text{O}_2$ ,  $\text{HNO}_3$ , peroxyacetyl nitrate (PAN) and ozone in air. PAN is an eye irritant and is also toxic to plants.

## 3. Ozone

Ozone,  $\text{O}_3$ , is a gas having low boiling point. It is present in small concentrations throughout the atmosphere. The amount of ozone in the atmosphere is expressed in Dobson units (DU). The normal amount of overhead ozone is about 350 DU.

The ozone layer, 25 - 28 km high, in the stratosphere surrounds the globe and filters most of the harmful ultraviolet (UV) rays in the sunlight before they could reach on the earth. Therefore, if there is substantial reduction in the ozone layer, the life on earth would be threatened. In 1980's a large hole in the ozone layer over Antarctic was discovered which represented a major environmental crisis.

Ozone is produced in most of the tropical regions by the photochemical reactions of oxygen, from where it is transported to Polar Regions. It acts as a pollutant and causes various health problems, i.e., damages eyes and aggravates asthma, decreases the elasticity of lung tissues resulting in coughing, chest discomfort, etc. It is harmful to the plants and other materials, i.e., attacks rubber, reduces durability and appearance of paint and causes fabric dyes to fade.

The amount of ozone is less in the regions closer to the equator. The thickness of the ozone layer has been decreasing over Antarctic during the spring time since the mid 1970's. By the mid 1980's loss in ozone at some altitudes over Antarctica resulted in about 50% depletion of the total overhead amount. The region in which ozone depletes substantially in every year during Sep-Nov is now termed as "ozone hole".

The concentration of ozone in the stratosphere is being depleted through various chemical reactions not only above Antarctica but worldwide.

The stratosphere where ozone layer exists in atmosphere is approximately at 15 to 40 km altitudes and is just above the troposphere which extends to an altitude of 0-15 kilometer from the earth. The temperature in troposphere decreases with the increasing altitude from 15 to  $-56^{\circ}\text{C}$ , it is because the air near the earth is heated by radiation reemitted from the earth. Whereas the temperature in stratosphere increases with increase of altitude, i.e.,  $-56$  to  $-2^{\circ}\text{C}$ . The ozone is the main chemical species present in stratosphere which absorbs the ultraviolet radiation and increases the temperature in the upper part of the ozone layer.

### Role of Chlorofluorocarbons (CFCs) in Destroying Ozone

Chlorofluorocarbons used as refrigerants in air conditioning and in aerosol sprays are inert in the troposphere but slowly diffuse into stratosphere, where they are subjected to ultraviolet radiation generating Cl free radicals. Chlorofluorocarbons (CFCs) play an effective role in removing  $\text{O}_3$  in the stratosphere due to following reactions.

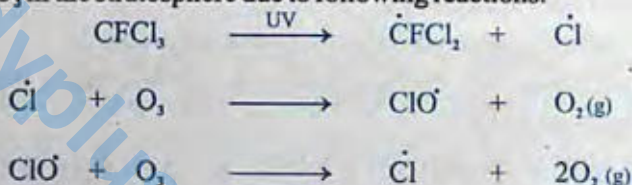

A single chloride free radical can destroy upto 100,000 ozone molecules.

### 16.2.3 Water Pollution

Water is essential for life on earth. All living organisms contain water in them. To sustain life, every human being drinks several litres of water daily. Marine life is also impossible without water. Surface and ground water which are vital resources of fresh water are vulnerable to contamination. The human activities such as livestock waste, landfills, agriculture, pesticides, oil leaks and spills, disposal of industrial effluents on open land, water bodies, septic tanks, detergents, mining, petroleum and natural gas production may result in the contamination of the surface and ground waters.

#### 1. Livestock Waste

Mostly the livestock waste is either being dumped on open land or is discharged into sewage, canals or rivers. This practice pollutes the surface and ground water posing serious health problems to the population. Chemical and bacterial contents in livestock waste can contaminate surface and ground water causing infectious diseases like dysentery, typhoid and hepatitis.

#### 2. Oil Spillage

Petroleum or crude oil is a complex mixture of many compounds mainly hydrocarbons. The petroleum products are used as fuel, lubricant, for manufacturing petrochemicals, plastics, electrical appliances, synthetic rubber and detergents, etc. Sea water gets polluted by accidental oil spills and leakage from cargo oil tankers in sea, tanker trucks, pipelines leakage during off shore exploration and leakage of underground storage tanks. Many petroleum products are poisonous and pose serious health problems to humans, animals and aquatic life. Hydrocarbons particularly polycyclic aromatics are known to be carcinogenic even at very low concentrations. The marine organisms are severely affected by soluble aromatic fractions of oil (C-10 or less).

The spilled oil damages the marine life often causing death. The light transmission through surface of water is affected by oily layer on it thus photosynthesis of the plants and dissolved oxygen in water is decreased.

### 3. Detergents

Detergents are excessively used in industries and household as cleaning agents. The amount of disposed detergents in waste water is increasing day-by-day. This waste water when discharged in rivers or sea, greatly affects the aquatic life. Detergent contents of waste water mobilize the bound toxic ions of heavy metals such as Pb, Cd and Hg from sediments into water.

### 4. Pesticides

Pests harm crops and transmit diseases both to human beings and animals. Pesticides are the substances that can directly kill an unwanted organism or otherwise control by interfering with its reproduction process. The current ability to produce large amounts of food on relatively small amount of land has been made possible around the world by the use of pesticides. At present more than ten thousand different types of synthetic organic pesticides have been formulated. They are broadly classified into several principal types according to their general chemical nature.

The most important and widely used pesticides are insecticides (which kill insects), herbicides (which kill undesired plants) and fungicides (which control the growth of fungus on the plant). The use of various pesticides also helped in the eradication of diseases such as malaria, yellow fever, bubonic plague and sleeping sickness.

Wide spread use of pesticides for getting greater crop yields if not properly checked and controlled has associated risks of contaminating the soil, plants and the water. The drainage water from the agricultural land (where the pesticides are being used) mostly contains pesticides. Therefore if the use of any type of pesticide is not properly controlled, it enters into the food chain through agricultural food products and drinking water and poses serious health problems to both human beings and animals.

Organic chemicals in drinking water do not have any healthy effects on human or animal health. At best, some organic chemicals may have no detrimental effects at low concentrations. But many compounds once thought safe, especially the synthetic organic chemicals, can have serious and substantial health risks, even at very low concentrations. At even higher concentrations, most of the compounds are tasteless and odourless. It is now known that many of the light molecular weight chlorinated hydrocarbons in drinking water are carcinogens and they have no safe levels. That is they cannot be consumed through air, food, or water without the risk of adverse health effects.

When synthetic organic chemicals are ingested through food or drinking water, they can cause health problems. At high concentrations they can cause nausea, dizziness, tremors, and blindness. At lower concentrations, at which these compounds become tasteless and odourless, humans may develop skin eruptions or central nervous system impairment. At still lower concentrations when ingested over months or years, the compounds can cause health problems. With human or animal carcinogens, there is often a long period of time between exposure and manifestation of the disease.

## 5. Industrial Waste Effluents

Finished products in any chemical related manufacturing industries, i.e., leather tanneries, fertilizers, oil refining, petrochemical, textiles, paper pulp and paper board, rubber products, agrochemicals, leather goods, etc., are always accompanied by some byproducts and waste effluents. Waste products may be in the form of waste heat, smoke, solid or waste water effluents.

The industrial waste pollutants may contain organic chemicals including highly toxic synthetic organic compounds and heavy metals, i.e., Pb, Cd, Cr, Hg, As, Sb etc. oils and greases, mineral acids, etc. The toxic organic compounds and heavy metals and metalloids result in contamination of both surface and ground water used for irrigation and potable water supply. This also causes irreversible degradation of the environment causing serious health problems for public and marine life. It must be mentioned here that heavy metals such as Pb, Cd, Cr, As, Hg, etc. are highly toxic and do not have any safe limits; they have accumulation effects when ingested through food or water and cause various health problems like anemia, kidney diseases, nervous disorder, high blood pressure, etc.

## 6. Leather Tanneries

Many leather tanning units, varying from the cottage scale to big industrial units, are working in and around many big cities of Pakistan. They use large quantities of chromium (VI) salts for leather tanning. They are producing good variety of exportable leather, but only some units have the facility of waste water treatment by reducing Cr (VI) into trivalent state followed by alkaline precipitation of  $\text{Cr}(\text{OH})_3$ . The effluents are discharged onto the open land or put into the sewage system. These industries are the big source of chromium (VI) pollution in the environment. Chromium (VI) is highly toxic and is known to cause cancer.

### 16.3 FACTORS AFFECTING THE QUALITY OF WATER

The terms dissolved oxygen, biochemical oxygen demand and chemical oxygen demand are frequently used in measuring the quality of water. These terms are described as follows:

#### 1. Dissolved Oxygen (DO)

In water the most important oxidizing agent is dissolved molecular oxygen ( $\text{O}_2$ ) the concentration of which ranges from 4 - 8 ppm. The organic matter is oxidized with the help of this dissolved oxygen in water. It is a parameter to determine the quality of water. The dissolved oxygen value less than 4 ppm indicates that water is polluted.

#### 2. Biochemical Oxygen Demand (BOD)

It is the capacity of organic matter in natural water to consume oxygen within a period of five days. The value of BOD is the amount of oxygen consumed as a result of biological oxidation of dissolved organic matter in the sample. The oxidation reaction is catalyzed by microorganisms which are already present in the natural water. It is measured experimentally by calculating the concentration of oxygen at the beginning and at the end of five days period, in which a sealed water sample is maintained in the dark at constant temperature either at  $20^\circ\text{C}$  or  $25^\circ\text{C}$ .

#### 3. Chemical Oxygen Demand (COD)

The organic content of water which consumes oxygen during chemical oxidation is

evaluated by its chemical oxygen demand. The oxygen demand of water can be determined directly by treating it with dichromate ions  $\text{Cr}_2\text{O}_7^{2-}$  which is a powerful oxidizing agent. The organic matter in water is oxidized, while the remaining dichromate is determined titrimetrically. Value of COD is a direct measure of chemically oxidizable matter in water. Higher values of COD will indicate more pollution.

### 16.3.1 Purification of Water

The surface or ground water is normally used for drinking and other domestic purposes. The quality of untreated surface or ground water varies largely from place to place. Ground water is usually more clean than the surface water. Depending upon its quality it may or may not need further treatment to make it fit for human consumption. The surface water, however, is invariably contaminated and requires treatment to make it potable i.e., safe for human consumption.

Raw water is treated to remove all the foreign materials and make it useable for drinking and other domestic purposes. The treatment is carried out in various stages, i.e., aeration to settle suspended matters, coagulation of small particles and suspended matters, precipitation and removal of solid matters and finally treating the water with chlorine to kill viruses and bacteria.

#### 1. Aeration

The quality of raw water is improved by aeration. In this process air is passed through water to remove the dissolved gases such as foul smelling  $\text{H}_2\text{S}$ , organosulphur compounds and volatile organic compounds. Some of the organic materials in the raw water which could be easily oxidized with air produce  $\text{CO}_2$  in the aeration process. The remaining portions of organic material if necessary are removed by passing water over activated carbon. Aeration process also oxidizes water soluble  $\text{Fe}^{2+}$  to  $\text{Fe}^{3+}$  which then forms insoluble  $\text{Fe}(\text{OH})_3$ , and can be removed as solid. Aeration also improves the oxygen level of raw water.

#### 2. Coagulation

The materials which are suspended or present in the colloidal form in raw water are removed by coagulation. The coagulant such as aluminium sulphate or alum is added to the raw water, which causes the precipitation of suspended impurities. For example, aluminium hydroxide is precipitated when alum is added to water in alkaline medium, i.e.,



Many suspended particles get adsorbed on the surface of gelatinous aluminium hydroxide precipitate. Ferric salts are also commonly used as coagulants but they are difficult to handle because an insoluble ferric oxide is produced in the pH range from 3.0 to 13.0.

The process of coagulation can remove more than 80% of the suspended solids in the raw water. The surface or ground water may also contain calcium and magnesium salts which make the water hard. The hard water is then appropriately treated to remove  $\text{Ca}^{2+}$  and  $\text{Mg}^{2+}$ .

#### 3. Water Disinfection by Chlorine

Chlorine is frequently used to disinfect water. Chlorine treatment is very effective in killing the pathogens that may cause serious water-borne diseases such as typhoid and cholera which have killed many thousands of people around the world. The most commonly used

disinfecting agent is hypochlorous acid HOCl. This neutral covalent compound kills microorganisms readily by passing through their cell membranes. The hypochlorous acid is not stable thus it cannot be stored, it is therefore generated by either dissolving molecular chlorine gas or sodium and calcium hypochlorites in water. Disinfection by chlorine is inexpensive.



Generating HOCl from sodium or calcium hypochlorites avoids the transportation and use of chlorine cylinders.

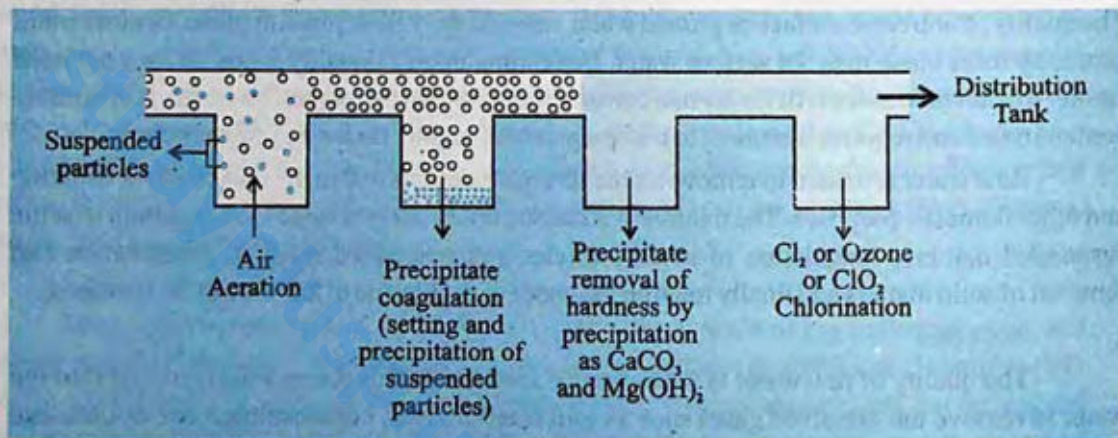

Fig. 16.1 Purification of water

Harmful effects of chlorination of water are due to its reactions with dissolved ammonia and organic matters present in water. The hypochlorous acid reacts with dissolved ammonia to form chloramines H<sub>2</sub>Cl, NHCl, and especially nitrogen trichloride NCl<sub>3</sub>, which is a powerful eye irritant.



The alkaline pH can prevent the formation of chloramines. Chlorination of water containing organic materials also forms some organic compounds which are toxic. For example, if phenol is present in water then chlorinated phenols are formed which have offensive odour and taste and are toxic.

Chloroform CHCl<sub>3</sub> is formed when hypochlorous acid reacts with organic matter (humic acid) dissolved in water. Chloroform is suspected liver carcinogen and also has negative reproduction and development effects in humans. The risk of bladder and rectal cancer increases by drinking chlorinated water. To avoid the formation of toxic compounds with chlorine, ozone or chlorine dioxide is used for the disinfection of water.

## 16.4 SOLID WASTE MANAGEMENT

The disposal of domestic refuse, commercial and industrial solid wastes or semisolid materials are studied under the title solid waste management. The domestic municipal solid waste mostly consists of papers, vegetables, plastics, wood, glass, rubber, leather, textile, metals and food wastes.

### 16.4.1 Effects of Dumping Waste in Sea and Rivers

Water covers more than 70% of the earth and is a valuable source for food and minerals. Sea and rivers have long been used for dumping waste of industrial and municipal discharges such as acids, refinery wastes, pesticides waste, construction and demolition debris, explosives, domestic refuse, garbage and radioactive waste, etc. The dumping of waste materials in water has damaged the marine environment and caused health hazards to human beings.

### 16.4.2 Landfill

The municipal solid waste is mainly disposed off by dumping it in a landfill. The landfill is a large hole in the ground or even a bare piece of land. When the landfill becomes full with waste it is covered by soil or clay. The site of land is selected on a number of factors such as topography, location of the ground, water table, nature of the solid waste, type of soil and rock and location of disposal zone in the surface water and ground water flow system. The ground water which seeps in the landfill and liquid from the waste itself all percolate through the refuse producing leachate. The leachate contains dissolved, suspended and microbial contaminants.

The gases which are produced in landfills from the waste are methane, ammonia, hydrogen sulphide and nitrogen. The leachate contains volatile organic acids such as acetic acid and various fatty acids, bacteria, heavy metals and salts of common inorganic ions such as  $\text{Ca}^{2+}$ . The micropollutants present in municipal solid waste include common volatile organic compounds such as toluene and dichloromethane.

### 16.4.3 Incineration of the Municipal Solid Waste

Incineration is a waste treatment process in which solid waste is burned at high temperatures ranging from 900 to 1000 °C. The burning of the solid waste in the incinerator consumes all combustible materials leaving behind the noncombustible materials and the ash residues. The ash residues of the incinerator are disposed off on the land or landfills. The incineration may reduce the volume of the waste by two third. The combustible components of garbage such as paper, plastics and wood provide fuel for the fire. In incineration the heat of combustion may be used in producing steam which runs the turbines to produce electricity.

### 16.4.4 Treatment of Industrial Waste

The industrial and hazardous wastes are disposed off in landfill or the waste is first incinerated and the residual ash is then disposed off in the landfill. The landfill for the hazardous waste is monitored more regularly for the leakage of the leachate and its design is almost same as that of landfill for the municipal solid waste, except it has more lining of clay and plastic so that the leachate does not contaminate soil and ground water around.

### 16.4.5 Incineration of Industrial and Hazardous Waste

A general process of high temperature incineration system consists of a rotary kiln which accepts all types of wastes including liquid, solid or sludge. The wastes are burned at temperatures between 650° to 1100°C. Ash from the rotating chamber is collected at waste tank and the remaining liquid gaseous materials are passed to the secondary chamber. This chamber is non-rotating and hence the temperature range of 950° to 1300°C is maintained. In this chamber organic molecules are completely destroyed. The gases produced are then cooled to 230°C by evaporating

water spray. The cooled gases are then passed through scrubber system which eliminates the surviving particulates and acid forming components like  $\text{CO}_2$ . Ash residues and waste water produced in the rotating and secondary chambers are disposed off in the landfills, Fig. 16.2.

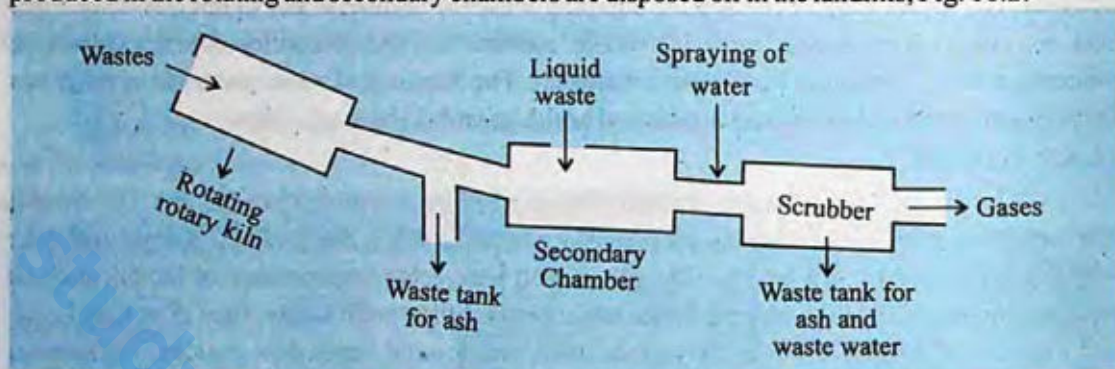

Fig. 16.2 Incineration of industrial waste

Although the volume of solid waste is reduced to a much lesser extent by burning it in the incinerator, it is not a clean process of the disposal of solid wastes, as it produces air pollution and also toxic ash. Incineration of the solid waste is a significant source of dioxins which is a class of carcinogen compounds. Smoke stacks from incineration may emit oxides of nitrogen and sulphur which lead to acid rain. Heavy metals such as lead, cadmium, mercury, etc., may also be present in the leachate of the incinerators.

#### 16.4.6 Recycling of Waste

In recycling some of the used or waste materials are not discarded after their initial use but are processed so that they can be used again. The purpose of recycling is to conserve sources such as raw material and energy. The volume of the waste is also much reduced by recycling of the materials. The most common domestic materials that are recycled are paper, plastic, glass and aluminium.

The largest item which is recycled is newspaper and in its recycling process the release of chlorine or other bleaching acids and organic solvents is significantly less as compared to formation of these compounds during the processing of virgin newspaper. To improve the whiteness of the recycled newspaper it is blended with the virgin newspaper or sometimes treated with peroxides and hydrosulphites. In recycling process the fibre of the newspaper becomes shorter so it can be recycled again and again for five times.

The recycling of plastics is done by reprocessing, depolymerization or transformation. In reprocessing the used plastics are remelted and styrene which is used for manufacturing of different products e.g., the original use of polystyrene is for the manufacturing of foam, packaging, cutlery, furniture, etc. but after its reprocessing it is used mostly for the manufacturing of toys, trays, etc.

The depolymerization is a process in which the used plastics are converted back into their original components by a chemical or thermal process so that these can be subsequently polymerized again e.g., polyethylene terephthalate can be thermally depolymerized in the presence of a catalyst and heat into its original components. The transformation is a process in

which used plastics are converted into low quality substances which are latter used for the production of other materials e.g., cracking of polyethylene at high temperatures gives its monomers which are used for the manufacturing of lubricants.

### KEY POINTS

1. Environmental chemistry is the branch of chemistry in which we study the sources, reactions, transportation and effects of the pollutants on the environment. The environment consists of four components.
2. The primary air pollutants are carbon monoxide, sulphur dioxide, sulphur trioxide, nitrogen oxides and hydrocarbons.
3. The acid rain is due to the oxides of sulphur and nitrogen which get mixed with rain water in the presence of pollutants to form sulphuric and nitric acids. The acid rain affects the soil, water and sculptural materials.
4. The main cause of photochemical smog is the presence of oxidants such as nitrogen oxides in the atmospheres. The hydrocarbons also play a key role for smog formation.
5. The ozone is a protective layer in the stratosphere which absorbs harmful ultraviolet radiation of the sun and thus blocks them to reach on the earth.
6. Water which is an essential requirement for all the living beings on the earth is being polluted by livestock waste, oil spillage, detergents, pesticides and industrial wastes. The water pollution results in many infectious diseases such as dysentery, typhoid, hepatitis and in some cases also cancer.
7. The potable water is purified by aeration, coagulation and chlorination. Although chlorination has saved many thousand lives by killing viruses and bacteria, it also forms some chlorinated organic compounds in water which are toxic.
8. Domestic municipal solid waste consists of paper, plastic, vegetables, wood, glass, rubber, leather, textile, metals and food wastes. The waste whether domestic or industrial is managed by disposing it off in landfills or it is initially incinerated and then the resulting ash is disposed off in the land or in landfills. The dumping of waste in ocean, sea and rivers has damaged the marine environment and caused health hazards for human beings.
9. In the recycling process instead of dumping the waste products i.e., paper, plastic, glass and aluminium, they are processed and made reusable. This process also reduces the volume of the waste.

### EXERCISE

#### Q.1 Fill in the blanks.

- (i) Only \_\_\_\_\_ of the total earth's water resources are available as fresh water.
- (ii) \_\_\_\_\_ is a smaller unit of biosphere which consists of community of organisms and their interaction with environment.
- (iii) Carbon monoxide is highly poisonous gas and causes suffocation if inhaled, it binds blood \_\_\_\_\_ more strongly than oxygen thus excluding oxygen from normal respiration.

- (iv) The elevated concentration of \_\_\_\_\_ is harmful for fish as it clogs the gills thus causing suffocation.
- (v) The ozone layer in the \_\_\_\_\_ surrounds the globe and filters most of the harmful UV rays in the sunlight before they could reach the earth.
- (vi) The presence of \_\_\_\_\_ in livestock waste can contaminate surface and ground water causing various infectious diseases.
- (vii) The substances which can directly kill the unwanted organisms are called \_\_\_\_\_.
- (viii) \_\_\_\_\_ is frequently used to disinfect water.
- (ix) Incineration is not a clean process because it produces air pollution and toxic \_\_\_\_\_.
- (x) A process in which some of the used or waste materials are not discarded after their initial use but are processed so that it can be used again is called \_\_\_\_\_.

**Q.2 Indicate true or false.**

- (i) Half of the mass of the atmosphere is concentrated in lower 10 km.
- (ii) The oceans cover approximately 71 percent of the earth.
- (iii) The volcanoes produce 55 % of  $\text{SO}_2$ .
- (iv) The reducing smog is due to the presence of nitric oxide.
- (v) Ozone is produced in the polar regions by the photochemical reaction of oxygen.
- (vi) The temperature in the troposphere decreases with the increasing altitude from 15 to  $-56^\circ\text{C}$ .
- (vii) Incineration is a waste treatment process in which solid waste is dumped in a land fill.
- (viii) Acid rain is due to the presence of oxides of sulphur and nitrogen which get mixed with the rain water.
- (ix) The heavy metals have a safe limit where they are not toxic.
- (x) The reprocessing of the plastics is to convert back to their components by a chemical or thermal process so that these can be used again.

**Q.3 Multiple choice questions. Encircle the correct answer.**

- (i) The pH range of the acid rain is  
(a) 7-6.5 (b) 6.5-6 (c) 6-5.6 (d) less than 5
- (ii) Peroxyacetylnitrate (PAN) is an irritant to human beings and it affects:  
(a) Eyes (b) ears (c) stomach (d) nose
- (iii) To avoid the formation of toxic compounds with chlorine which substance is used for disinfecting water.  
(a)  $\text{KMnO}_4$  (b)  $\text{O}_3$  (c) Alums (d) Chloramines
- (iv) A single chloride free radical can destroy how many ozone molecules:  
(a) 100 (b) 100000 (c) 10000 (d) 10

- (v) Fungicides are the pesticides which:
- (a) control the growth of fungus (b) kill insects  
(c) kill plants (d) kill herbs
- (vi) Ecosystem is a smaller unit of:
- (a) lithosphere (b) hydrosphere  
(c) atmosphere (d) biosphere
- (vii) The main pollutant of leather tanneries in the waste water is due to the salt of:
- (a) lead (b) chromium(VI)  
(c) copper (d) chromium (III)
- (viii) In purification of potable water the coagulant used is:
- (a) nickel sulphate (b) copper sulphate  
(c) barium sulphate (d) alum
- (ix) The temperature in the non-rotating chamber in the incineration of industrial and hazardous waste process has a range:
- (a) 900 to 1000°C (b) 250 to 500°C  
(c) 950 to 1300°C (d) 500 to 900°C
- (x) Newspaper can be recycled again and again by how many times?
- (a) 2 (b) 3 (c) 4 (d) 5
- Q.4 Discuss in detail the components of the environment.
- Q.5 Describe the natural and human sources of carbon monoxide, nitrogen oxides and sulphur oxides.
- Q.6 What is acid rain and how does it affect our environment.
- Q.7 What is smog? Explain the pollutants which are the main cause of photochemical smog.
- Q.8 Why is ozone layer depleting? What will happen when the concentration of ozone will be decreased?
- Q.9 How is oil spillage affecting the marine life?
- Q.10 How detergents are threat to aquatic animal life?
- Q.12 Explain how pesticides are dangerous to human beings.
- Q.13 Discuss industrial waste effluents.
- Q.14 How water is purified i.e., made potable. Discuss in detail.
- Q.15 What are leachates?
- Q.16 Explain the process of incineration of industrial waste.

# GLOSSARY

<b>Absolute alcohol:</b>	100% Ethyl alcohol.
<b>Acid anhydride:</b>	A compound formed by the dehydration of carboxylic acid.
<b>Acid rain/Acid deposition:</b>	The formation of sulphuric and nitric acids from the oxides of sulphur and nitrogen in the atmosphere in the presence of water and pollutants.
<b>Acidic amino acid:</b>	Amino acid which contains two carboxyl groups and one amino group.
<b>Actinides:</b>	The elements from Th to Lr in which the 5f shell is in the process of completion.
<b>Addition Polymerization:</b>	The addition of unsaturated monomers to form one product.
<b>Aeration:</b>	The bubbling of air through water or sprinkling of water into air.
<b>Alcohol:</b>	Organic compounds containing -OH functional group.
<b>Aldehydes:</b>	Organic compounds containing a carbonyl functional group which is bonded to at least one hydrogen atom.
<b>Aldol:</b>	A compound containing both aldehydic and alcohol functional groups.
<b>Alkali-metals:</b>	Elements present in IA group.
<b>Alkaline earth metals:</b>	Elements present in group IIA.
<b>Alkanes:</b>	They are also known as paraffins with general formula $C_nH_{2n+2}$ . Alkanes are saturated hydrocarbons and are chemically inert.
<b>Alkenes:</b>	Alkenes are unsaturated hydrocarbons containing a C=C and having a general formula $C_nH_{2n}$ .
<b>Alkyl halides:</b>	Monohalo derivatives of alkanes
<b>Alkynes:</b>	Alkynes are unsaturated hydrocarbons which contain C≡C. They have a general formula $C_nH_{2n-2}$ .
<b>Amide:</b>	An organic compound containing -CONH <sub>2</sub> functional group.
<b>Amino acids:</b>	Organic compounds containing both amino and carboxyl groups.
<b>Amphoteric oxides:</b>	Oxides which behave as acids when react with bases and behave as bases when react with acids.
<b>Antiseptics:</b>	Substance (or materials) which can stop the growth of micro-organism if applied on living tissues, e.g. iodine.
<b>Aqua regia:</b>	A mixture containing three volumes of concentrated HCl and one volume of concentrated HNO <sub>3</sub> .
<b>Aromatic hydrocarbons:</b>	This is a class of organic compounds which includes the benzene and all compounds that are structurally related to benzene.
<b>Aryl radicals:</b>	The removal of hydrogen atom from benzene molecule gives phenyl radical (-C <sub>6</sub> H <sub>5</sub> ) and the radicals of aromatic hydrocarbons are called "Aryl radicals".
<b>Asbestos:</b>	A hydrated calcium magnesium silicate CaMg <sub>3</sub> (SiO <sub>3</sub> ) <sub>4</sub> .
<b>β-Elimination reactions:</b>	Reactions of alkyl halides which involve the loss of two atoms or groups from the adjacent carbon atoms to give an alkene.

- Baeyer's test:** It is a test performed to detect the presence of a C=C. Add dilute alkaline solution of  $\text{KMnO}_4$  to an alkene, purple colour of permanganate solution disappears.
- Basic amino acid:** An amino acid which contains two amino and one carboxyl groups.
- Benedict's solution:** An alkaline solution containing a cupric citrate complex ion.
- Biosphere:** The earth, oceans and atmosphere with which the living organisms interact.
- Bleaching agents:** Chemicals, generally oxidants, which remove colours, e.g. oxygen, hydrogen per oxide, ozone, chlorine, chlorine dioxide etc.
- Borax bead test:** A test performed with borax for the detection of coloured basic radicals such as  $\text{Cu}^{2+}$ ,  $\text{Cr}^{3+}$ ,  $\text{Ni}^{2+}$ , etc.
- Borax:** Sodium tetraborate decahydrate  $\text{Na}_2\text{B}_4\text{O}_7 \cdot 10\text{H}_2\text{O}$ .
- Carbocation:** An alkyl ion having a positive charge on a carbon atom.
- Carboxyl group:** Functional group having a formula  $-\text{COOH}$ .
- Carboxylic acid:** Organic compounds containing carboxyl group.
- Carcinogenic:** The substances which cause cancer.
- Cement:** It is the material obtained by burning an intimate mixture of calcareous (lime bearing) and argillaceous (clayey) materials at sufficiently high temperature to produce clinkers which are subsequently ground to a fine powder.
- Chain isomerism:** This type of isomerism arises due to the difference in the nature of carbon chain.
- Chelate:** When all the donor atoms of a polydentate ligand get coordinated with the same metal ion, resulting complexes are called chelates.
- Chemotherapy:** Selective destruction or prevention of pathogenic organisms with the help of chemicals (medicine).
- Cis-trans isomerism:** Such compounds which possess the same structural formula but differ with respect to the position of identical groups in space.
- Cis-trans isomerism:** Such compounds which possess the same structural formula but differ with respect to the position of identical groups in space.
- Coagulation:** Precipitation of the suspended solids present in a liquid by altering the surface characteristics of the solids.
- Combustion:** The burning of a compound in presence of air is called combustion.
- Condensation polymerization:** The joining together of monomers to produce a polymer together with the elimination of a small molecule like water.
- Condensation reactions:** The reactions in which two molecules of same or different compounds combine to form a new compound with or without the elimination of a small molecule like  $\text{H}_2\text{O}$  or  $\text{NH}_3$ .
- Coordination number:** The number of electron pairs accepted by the central metal atom or ion.
- Cracking:** The process of chemical decay of metals due to the effect of surrounding.
- Corrosion:** The thermal decomposition of higher hydrocarbons having high boiling points into lower hydrocarbons with low boiling points in the presence of a catalyst.
- Cryolite:** An ore of aluminum,  $\text{Na}_3\text{AlF}_6$ .
- Dehydrating agent:** A compound which has the capability to extract water from other compounds.

<b>Dehydrogenation:</b>	Removal of hydrogen from a compound is called dehydrogenation.
<b>Deliquescent:</b>	A compound which absorbs moisture.
<b>Detergents:</b>	The cleansing agents used in house-hold and industries.
<b>Digester:</b>	This is the main unit of the pulp formation. It is usually 30 feet in length and 7 feet in diameter. It is made of steel and wrought iron.
<b>Dihydric alcohol:</b>	Alcohols containing two - OH groups
<b>Dimer:</b>	An association of two identical molecules linked together.
<b>Disaccharides:</b>	These are sugars which on hydrolysis yields two monosaccharaides units.
<b>Disproportionation reaction:</b>	A reaction in which the same substance is both oxidized and reduced.
<b>E1 reactions:</b>	Two step elimination reactions in which the leaving group leaves first followed by the removal of hydrogen.
<b>E2 reactions:</b>	One step elimination reactions in which both the atoms or groups leave simultaneously.
<b>Electrophile:</b>	A reagent which can attract an electron pair to form a covalent bond.
<b>Environmental chemistry:</b>	The branch of chemistry which deals with the sources, reactions, transportation of the pollutants and their adverse effects on human beings.
<b>Environmental pollution:</b>	The substances in the environment which have adverse effects on the human health, quality of life or the natural functioning of the ecosystem.
<b>Enzymes:</b>	Enzymes are biological catalysts.
<b>Essential amino acid:</b>	Amino acids which cannot be synthesized by human body.
<b>Ester:</b>	Organic compound formed by the reaction between an alcohol and a carboxylic acid and has a general formula $R - COOR'$ .
<b>Esterification:</b>	A reaction of an alcohol with an organic acid in the presence of mineral acid to produce ester and water.
<b>Ether:</b>	Organic compounds having $R - O - R'$ linkage.
<b>Fehling's solution:</b>	An alkaline solution containing a cupric tartarate complex ion.
<b>Fermentation:</b>	A bio-chemical process which occurs in the presence of microorganisms.
<b>Fertilizers:</b>	These are the substances added to the soil to make up the deficiency of essential elements like nitrogen, phosphorus and potassium required for the proper growth of plants.
<b>Fluorspar:</b>	An ore of fluorine, $CaF_2$
<b>Formalin:</b>	A mixture of 40% formaldehyde, 8% methyl alcohol and 52% water.
<b>Functional group isomersism:</b>	Compounds having the same molecular formula but different functional groups, are called functional group isomers and the phenomenon is known as fimctional group isomerism.
<b>Functional group:</b>	An atom or a group of atoms or a double bond or a triple bond whose presence confers specific properties to organic compounds.
<b>Fungicide:</b>	Materials used to prevent fungi attack on crops, wood, paper, etc.
<b>Haloalkanes:</b>	Halogen derivatives of alkanes.
<b>Halohydrin:</b>	It is formed due to addition of hypohalous acid to the double bond of alkenes.
<b>Halothane <math>CHBrClCF_3</math>:</b>	A non-inflammable heavy' liquid used as a general anaesthetic when mixed with $O_2$ or $N_2O$ .

<b>Herbicides:</b>	Materials used to control herbs.
<b>Hetrocyclic compounds:</b>	Cyclic Organic compounds in which the ring contains more than one type of atoms.
<b>Homocyclic or carbocyclic compounds:</b>	Organic compounds in which rings are formed by carbon atoms only.
<b>Hybridization:</b>	The mixing of atomic orbitals of different energy and different shapes to give rise to hybridized orbitals of same energy and same shape.
<b>Hydrogenation:</b>	When a mixture of hydrogen gas and an unsaturated hydrocarbon (alkene or alkyne) is passed over finely divided platinum or nickel as catalyst, it is converted to alkane. This process is known as catalytic hydrogenation.
<b>Hydrosphere:</b>	It consists of all the water resources.
<b>Insecticides:</b>	Materials used to control insects.
<b>Isomerism:</b>	Different compounds having the same molecular formula but different structural formulas are called isomers and the phenomenon is known as isomerism.
<b>Ketones:</b>	A family of organic compounds in which carbonyl group is bonded to two carbon atoms.
<b>Lanthanides:</b>	The elements from Ce to Lu in which the 4f shell is in the process of completion.
<b>Lignin:</b>	Lignin is an aromatic polymer which causes paper to become brittle.
<b>Lindlar's catalyst:</b>	It is a very effective catalyst in which finely divided palladium is precipitated as BaSO <sub>4</sub> and then treated with quinoline. It is used for the reduction of an alkyne to a cis-alkene.
<b>Lithosphere:</b>	It consists of the earth's crust.
<b>Macro-nutrients:</b>	The nutrients which are required in a very large amount for the growth of plants. These are generally required in quantities ranging from 5 kg to 200 kg per acre.
<b>Macromolecule:</b>	A giant molecule which is often a polymer.
<b>Markownikov's rule:</b>	It states that addition of halogen acids to unsymmetrical alkene occurs in such a way that hydrogen atom gets attached to that carbon atom of the double bond which is already holding the larger number of hydrogen atoms.
<b>Marsh gas:</b>	Methane is known as Marsh gas, as it is found in swamps or marshy lands where it is formed by bacterial decomposition of complex vegetable and animal matter.
<b>Metalloids:</b>	The elements having properties of metals as well as of nonmetals.
<b>Metamerism:</b>	This type of isomerism arises due to the unequal distribution of carbon atoms on either side of a functional group.
<b>Methylated spirit:</b>	Ethyl alcohol containing 5-10% methyl alcohol.
<b>Micro-nutrients:</b>	The nutrients which are required in very small amount for the growth of plants.
<b>Molasses:</b>	Dark brown coloured liquid substance obtained after the crystallization of cane sugar. It contains 50% sugar.
<b>Molecularity:</b>	The number of molecules taking part in the rate determining step of a reaction.
<b>Monohydric alcohol:</b>	Alcohols containing only one -OH group.
<b>Monosaccharides:</b>	These are simple sugars which cannot be hydrolyzed further.

<b>Noble gases (Rare gases):</b>	The elements helium, neon, argon, krypton, xenon and radon are known as noble gases. They form the VIIIA or zero group of the table.
<b>Non-essential amino acids:</b>	Amino acids which can be synthesized by the human body.
<b>Nucleophile:</b>	A reagent which possesses an electron pair to form a covalent bond.
<b>Nucleophilic addition reactions:</b>	Reactions shown by aldehydes and ketones in which the nucleophile combines with the electrophilic carbon of the carbonyl group, whereas the positive part goes to the oxygen. In the case of aldehydes, the negative part of the reagent combines with the electrophilic carbon of the carbonyl group, whereas the positive part goes to the oxygen.
<b>Nucleophilic substitution reaction:</b>	Reactions in which the attacking nucleophile replaces the nucleophile already present in the substrate molecule.
<b>Octane number:</b>	The percentage of branched chain hydrocarbon, isooctane, in gasoline fraction of petroleum.
<b>Orientation:</b>	The method of determining the arrangement of substituents on the benzene ring for an unknown derivative is known as orientation.
<b>Ozonolysis:</b>	When a stream of ozone is passed through a solution of alkene in an inert solvent like ether or carbon tetrachloride, it adds a molecule of ozone at the double bond to give an ozonide. It is also used to locate a double bond.
<b>Paper:</b>	Paper is defined in terms of its method of production that is a sheet material made up of a network of natural cellulosic fibres which have been deposited from an aqueous suspension. The product obtained is a network of interlocking fibres.
<b>Paramagnetic substances:</b>	Those substances which have unpaired electrons.
<b>Peptide linkage or bond:</b>	A linkage formed by the reaction between a carboxyl (-COOH) group and an amino (-NH <sub>2</sub> ) group with the elimination of water molecule.
<b>Pesticides:</b>	The substances which can directly kill unwanted organisms or otherwise control by interfering with its reproduction process.
<b>Phenol:</b>	Aromatic compounds containing -OH functional group.
<b>Pig iron or cast iron:</b>	The iron coming out of blast furnace containing 2.52-4.5% carbon along with other impurities.
<b>Polyhydric alcohol:</b>	Alcohols containing more than two -OH groups.
<b>Polysaccharides:</b>	These are poly sugars which on hydrolysis yield many monosaccharide units.
<b>Polythene or polyethylene:</b>	A white translucent thermoplastic material made by polymerization of ethylene. It is used to make flexible pipes, sheets and bags.
<b>Position isomerism:</b>	The isomerism which arises due to the difference in the position of the same functional group on the carbon chain.
<b>Primary alcohol:</b>	An alcohol in which -OH group is attached directly with a primary carbon, primary carbon.
<b>Quartz:</b>	Crystalline form of silica.
<b>Rancidity:</b>	The foul odour given off from spoiled oil or fat.
<b>Rectified spirit:</b>	Ethyl alcohol containing 5% water.
<b>Recycling:</b>	Some used or waste materials are not discarded after their initial single use but are processed so that they can be used again.
<b>Reforming:</b>	Thermal conversion of straight chain hydrocarbons into branched chain hydrocarbons in the absence of oxygen and in the presence of a catalyst, this process improves the octane number of fuel.

<b>Resonance:</b>	The situation in which two or more plausible Lewis structures can be written but the actual structure cannot be written is called Resonance.
<b>Ring test:</b>	A confirmatory test for the presence of nitrate ions in an aqueous solution. The solution is treated with ferrous sulphate solution in the presence of concentration $H_2SO_4$ , whereby a brown ring is formed.
<b>Saponification:</b>	It is the hydrolysis of a fat or an oil with an alkali to form soap and glycerol.
<b>s-Block elements:</b>	In these elements the last electron enters the s-orbital of the ultimate (outermost) shell.
<b>Secondary alcohol:</b>	An alcohol in which -OH group is attached with a secondary carbon.
<b>Semiconductor:</b>	A substance which conducts electricity better than an insulator.
<b>Silicones:</b>	A polymer containing silicon - oxygen chains and alkyl groups attached to silicon atoms.
<b>Slaking:</b>	The hydration reaction of lime.
<b>Slurry:</b>	A suspension containing an appreciable quantity of a solid.
<b>Smog:</b>	Combination of smoke and fog. If the concentration of sulphur dioxide is high it is called reducing smog and when the concentration of the oxidants is high it is known as oxidizing smog
<b>SN1 reactions:</b>	Two step nucleophilic substitution reactions in which the leaving group leaves first followed by the attack of the nucleophile.
<b>SN2 reactions:</b>	A nucleophilic substitution reaction in which the bond aition and bondbreakage take place simultaneously. Formation and bond breakage take place simultaneously.
<b>Soda lime:</b>	A solid mixture of CaO and NaOH.
<b>sp hybridization:</b>	Mixing of one s and one p orbitals to give rise to two sp hybridized orbitals which are linear in shape.
<b>sp<sup>2</sup> hybridization:</b>	Mixing of one s and two p orbitals to give rise to three hybridized sp <sup>2</sup> orbitals having a planar triangular shape.
<b>sp<sup>3</sup> hybridization:</b>	Mixing of one s and three p orbitals to give rise to four hybridized orbitals which are directed towards four corners of a regular tetrahedron.
<b>Steel:</b>	Iron containing 0.25 -2.50% carbon alongwith other additives.
<b>Terpolymer:</b>	A polymer obtained by the polymerization of three monomers.
<b>Tertiary alcohol:</b>	An alcohol in which -OH is directly attached with a tertiary carbon.
<b>Thermoplastic:</b>	A plastic which can be softened repeatedly when heated and becomes hard when cooled.
<b>Thermosetting:</b>	A plastic which becomes hard on heating and cannot be softened again.
<b>TNT:</b>	Trinitrotoluene, an explosive compound.
<b>Tollen's Reagent:</b>	Ammonical silver nitrate solution.
<b>Transition elements:</b>	Elements which have partially filled d or f sub-shells in atomic or in any of their stable oxidation states.
<b>Vinegar:</b>	10% aqueous solution of acetic acid.
<b>Weed killers:</b>	Chemicals used to control selectively unwanted vegetation on agricultural land.
<b>Wrought iron:</b>	Iron containing 0.1-0.25% carbon.
<b>Zwitter ion:</b>	An ion that has positive and negative charges present within the molecule.

# INDEX

## A

Absolute alcohol, 33  
 Absorption unit, 71  
 Acetaldehyde, 229, 231  
 Acetate ion, 144  
 Acetic acid, 137, 144, 245, 245  
 Acetone, 122, 200, 230  
 Acetylene, 23, 33, 156, 161  
 Acetyl chlorides, 256, 266  
 Acid number, 283  
 Acid rain, 310, 321  
 Acid-base reaction, 27  
 Acid-catalyzed addition reactions, 239  
 Acidic behavior of phenol, 220  
 Acidic oxides, 45, 57  
 Acidic soils, 32  
 Acrylic resin, 272  
 Actinides, 4, 5, 100  
 Active metal, 68, 110  
 Acyclic compounds, 123, 124  
 Acylation, 184, 185, 193  
 Addition of ammonia derivatives, 160, 285  
 Addition of oxygen, 154  
 Addition polymerization, 270  
 Addition reactions, 151, 158  
 Aeration, 215, 315  
 Air pollution, 123, 308, 318  
 Alcoholic potassium hydroxide, 149, 253  
 Alcohols, 65, 149, 207  
 Aldehyde, 144, 228, 230  
 Alicyclic compounds, 125  
 Aliphatic carboxylic acid, 250, 264  
 Aliphatic compounds, 123  
 Alkadienes, 141  
 Alkali metals, 4, 6, 22  
 Alkanes, 122, 136, 142  
 Alkatrienes, 141  
 Alkenes, 122, 136, 148  
 Alkyl hydrogen sulphate, 153  
 Alkyl chlorides, 197, 255  
 Alkyl groups, 50, 138, 223  
 Alkyl halides, 143, 194  
 Alkyl magnesium halides, 145  
 Alkynes, 136, 157  
 Allotropes, 57, 64  
 Allotropic form of oxygen, 155  
 Allotropic forms, 64, 69  
 Allotropes of phosphorus, 64  
 Alloy formation, 103  
 Alloy steels, 103  
 Alum, 32  
 Alumina, 122  
 Aluminium triethyl catalyst, 156  
 Alumino-silicate minerals, 38  
 Amethyst quartz, 46  
 Amide, 233, 256  
 Amino acids, 250, 259  
 Ammonium cyanate, 118  
 Ammonium nitrate, 58, 63

Ammonium sulphate, 74  
 Amphoteric oxides, 14  
 Amylopectin, 276  
 Anaesthetic, 156  
 Anionic coordination sphere, 104  
 Anionic ligands, 105  
 Anode coating, 111  
 Antiknock agent, 123  
 Aqua regia, 63  
 Aqueous solution, 14  
 Aromatic carboxylic acid, 250  
 Aromatic compounds, 125  
 Aromatic hydrocarbons, 169  
 Asbestos, 49, 50  
 Atmosphere, 307  
 Atomic numbers, 5  
 Atomic orbital, 128  
 Atomic radius, 5, 56

## B

Bacterial action, 309  
 Baeyer's reagent, 155  
 Bakelite, 222  
 Barbituric acid, 137  
 Barium nitrite, 60  
 Basic behaviour, 13  
 Basic character, 13  
 Basic oxides, 62  
 Backmann's method, 88  
 Banzaldehyde, 229  
 Benedict's solution test, 245  
 Benzene sulphonic acid, 74, 183  
 Benzene, 74, 120, 122  
 Benzoic acid, 179  
 Bessemer's converter, 108  
 Bessmer process, 107, 108  
 Bidentate ligands, 104  
 Binding energies, 100  
 Biochemical decomposition, 121  
 Biochemical oxygen demand (BOD), 314  
 Biopolymers, 273  
 Biosphere/exosphere, 308  
 Biphenyl, 170  
 Birkland and Eyde's Process, 61  
 Bisulphite addition product, 234  
 Black phosphorus, 64  
 Bleaching of the fabric, 33  
 Bleaching powder, 33, 88  
 Boiling points, 9, 68  
 Bond cleavage, 143  
 Bond energies, 13  
 Borates, 39  
 Borax bead test, 40, 41  
 Borax, 39  
 Boric acids, 41  
 Boric anhydride, 42  
 Branched-chain alkanes, 138  
 Brass, 103  
 Bromination, 181  
 Bromine water, 60  
 Bromonium ion, 154

Bronze, 103  
 2-Butanone, 230  
 Butane, 123  
 Butyraldehyde, 229

## C

Calcium borate, 39  
 Calcium carbide, 33, 158  
 Calcium magnesium silicate, 49  
 Calcium oxide, 108  
 Calcium phosphate, 64, 108  
 Camphor, 228  
 Cannizzaro's reaction, 237  
 Carbocation, 152  
 Carbocyclic compounds, 124  
 Carbohydrates, 120, 273, 275  
 Carbon disulphide, 64, 65  
 Carbon tetra chloride, 148  
 Carbonates, 109  
 Carbonization, 120  
 Carbonyl compounds, 144  
 Carbonyl group, 228  
 Carboxyl group, 250  
 Carboxylic acids, 250  
 Carcinogenic, 312  
 Catalytic cracking, 122  
 Catalytic hydrogenation of alkene, 152  
 Catalytic hydrogenation, 143, 152  
 Catalytic oxidation, 146, 147  
 Catalytic reduction, 243  
 Catenation, 46, 69, 119  
 Cathode coating, 111  
 Cationic coordination sphere, 104  
 Caustic soda, 42, 143  
 Cellulose, 275  
 Cement, 32, 295  
 Cement industry in Pakistan, 299  
 Central metal atom, 104  
 Central metal ion, 104  
 Chain isomerism, 131  
 Chelates, 104  
 Chemical forces, 119  
 Chemical oxygen demand (COD), 314  
 2-chlorobutanol, 229  
 Chlorination, 181  
 Chlorofluoro carbons, 312  
 Chloroform, 148  
 Chloropropane, 132  
 Cholesterol, 283  
 Chromate ions, 112  
 Chromates, 111  
 Chromic acid, 111  
 Chromic anhydride, 111  
 Chromium, 107  
 Chromyl chloride test, 113  
 Chromyl chloride, 113  
 Cinnabar, 69  
 Cis-trans isomers, 133  
 Classification of alcohols, 212  
 Classification of enzymes, 285  
 Classification of hydrocarbons, 137

Classification of macromolecules, 268  
 Classification of organic compounds, 124  
 Classification of proteins, 277  
 Classification of steel, 107  
 Clemmensen reduction, 144  
 Clinker, 32, 296  
 Closed chain compounds, 124  
 Coal, 120, 121  
 Cobalt, 107  
 Coinage alloys, 103  
 Coinage metals, 98  
 Colemanite, 39, 41  
 Colour, 102  
 Combustion, 146  
 Commercial iron, 106  
 Complete combustion, 146  
 Complex anion, 103  
 Complex cation, 103  
 Complex compounds, 103  
 Complex ion, 103  
 Complex molecules, 103, 137  
 Complexity of organic compounds, 119  
 Components of environment, 307  
 Condensation polymerization, 270  
 Condensation reaction, 235  
 Coagulation, 315  
 Contact process, 70  
 Contact tower, 71  
 Coordinated ligands, 105  
 Coordination complexes, 103  
 Coordination compounds, 103  
 Coordination number, 104  
 Coordination sphere, 104  
 Copolymer, 270  
 Copper acetylides, 162  
 Copper pyrite, 69  
 Corrosion, 109  
 Covalent bonding, 57  
 Covalent bonds, 57  
 Covalent halides, 12  
 Covalent hydrides, 12  
 Covalent radii, 101  
 Cracking of petroleum, 122  
 Cracking, 122  
 Crude oil, 121, 122, 289, 310, 312  
 Crude petroleum, 121  
 Crystal lattice, 48  
 Crystalline solid, 12, 28, 39, 112  
 Cupric borate, 40  
 Cuprous chloride, 161, 162  
 Cyanohydrins, 233  
 Cyclic compounds, 123, 124, 125  
 Cyclohexane, 136, 152, 174, 176

## D

Decarboxylation, 143  
 Dehalogenation of tetrahalides, 157  
 Dehydrating agent, 33, 66, 73, 75  
 Dehydration of alcohols, 149  
 Dehydration, 149, 218, 294  
 Dehydrogenation of cyclohexane, 178  
 Dehalogenation, 150, 157  
 Dehydrohalogenation of alkyl halides, 149  
 Dehydrohalogenation of  
 Vicinal Dihalides, 150, 157  
 Deliquescent crystalline solid, 68  
 Delocalized electron cloud, 175  
 Denaturing of alcohol, 215  
 Denaturation of Proteins, 278

Destructive distillation, 121  
 Detergents, 120, 122, 279, 313, 312, 314  
 D-glucose, 274, 275  
 Diamagnetic, 70, 101  
 Diammonium phosphate, 295  
 Diatomic, 15, 46, 69  
 Dicarboxylic acid, 150, 157, 271  
 Dichromate ions, 112, 315  
 Dichromates, 111, 112  
 Dienes, 148  
 Diethyl ether, 132, 211, 223, 281  
 Digester, 301  
 Dihalide, 150, 153, 156, 159  
 Dihydroxy compounds, 155  
 Diamagnetic substances, 101  
 2,4-Dinitrophenylhydrazine, 241  
 Dinitrogen oxide, 58  
 Dinitrogen tetraoxide, 59  
 Dinitrogen trioxide, 60  
 Dioxalato platinate, 105  
 Diphenylmethane, 170  
 Dipole moment, 46  
 Disaccharides, 274  
 Dissolved oxygen (DO), 314  
 Distinction between primary, secondary  
 and tertiary alcohols, 218  
 Divalent, 69, 128, 129  
 Divinyl acetylene, 161  
 DNA, 287  
 Dolomite, 108  
 Dow's method, 219  
 Ductile, 100, 107

## E

Electrochemical process, 110  
 Electrochemical series, 110  
 Electrochemical theory, 110  
 Electrolysis of salts of  
 Dicarboxylic acid, 150  
 Electrolysis of salts, 157  
 Electrolysis, 29, 30, 36, 114  
 Electrolytic oxidation  
 process, 114  
 Electrolytic oxidation, 114  
 Electron affinity, 8, 21, 38, 44  
 Electronegativity, 11, 12, 13, 21  
 24, 38, 56, 68, 198  
 Electronic configuration, 37, 97  
 Electrophile, 146; 180, 181, 183, 188,  
 189, 198, 199, 205, 216  
 Electrophilic reactions, 151  
 Electrophilic reagents, 151, 154, 158,  
 162, 164, 190  
 Electrophilic substitution reactions, 181  
 Electropositive character, 45  
 Electropositive elements, 11, 14  
 Endothermic, 24  
 Environmental Chemistry, 306  
 Environmental pollutant, 307  
 Enzymes, 120  
 Epoxy resin, 272  
 Equilateral triangle, 128  
 Equivalent tetravalency of carbon, 127  
 Ergosterol, 282  
 Essential and non-essential amino acids, 259  
 Essential elements, 119  
 Essential oils, 229  
 Ester, 120, 255  
 Ethance, 122  
 Ether, 120, 121, 211, 222

Ethyl alcohol, 157  
 Ethyl halide, 157  
 Ethylene dibromide, 89  
 Ethyne, 157  
 Exothermic process, 152  
 Exothermic, 24, 71

## F

Factors affecting enzyme activity, 286  
 Fats and oils, 251, 279, 280, 281  
 Fatty acids, 143, 147, 251, 278,  
 279, 280, 281, 283, 284, 317  
 Fehling's solution test, 244  
 Feldspar, 49, 53  
 Ferric oxide, 49, 109, 315  
 Ferric sulphate, 112  
 Ferrocyanide ion, 103  
 Ferromanganese, 108, 109  
 Ferro-silicon, 109  
 Ferrous sulphate, 48, 60, 112  
 Fertilizer industries, 121  
 Fertilizer industry in Pakistan, 295  
 Fertilizer, 108, 121, 148, 291-296  
 Filler, 32, 48, 297  
 Flash light photography, 43  
 Flue gases, 108  
 Fluorescent tubes, 93  
 Fluorides of xenon, 92  
 Fluorinated alkanes, 147  
 Fluorinating agent, 92  
 Fluorination, 181, 186  
 Fluorochlorocarbons, 89  
 Formaldehyde, 148, 222, 229, 230, 231,  
 237, 239  
 Fossil fuels, 120  
 Fourdriner paper making, 303  
 Fractional distillation, 120, 121, 122, 289  
 Free radical mechanism, 147  
 Freon, 89  
 Friedel-Crafts reactions, 184  
 Friedrich Wöhler, 118  
 Fructose, 273, 274, 285  
 Functional group isomerism, 131  
 Functional group, 118, 125, 126, 132, 134, 195,  
 212, 213, 228, 235, 250, 255, 271, 285  
 Fungicides, 313  
 Furnace with acidic lining, 108

## G

Galena, 69  
 Galvanic cell, 110, 111  
 Galvanizing coating, 111  
 Galvanizing, 111  
 Gasoline fraction, 122  
 Gasoline, 122  
 Geometric isomers, 132  
 Gasoline, 122, 123, 204, 309  
 Geometric isomers, 133  
 Geometric isomerism, 133  
 Geometry of complexes, 105  
 Glass lasers, 93  
 Glucose, 273  
 Glycerine, 40, 52, 63  
 Glycerol, 42, 227, 279-282  
 Glycogen, 275, 277  
 Glycols, 154, 155, 156  
 Grignard reagents, 145, 234  
 Glycosidic linkage, 274, 277

Gypsum, 20, 29, 31, 32, 69, 296, 297, 298, 299

## H

Haematite, 106

Halide ion, 152

Halides of phosphorus, 56, 64

Halides, 11, 12, 22-27, 56, 64, 143, 145, 149, 152, 156, 159, 194-204, 218, 223, 256

Haloalcohol, 154

Haloform reaction, 238

Halogenating agent, 182

Halogenation, 147, 154, 181, 186, 188, 197, 222

Halogenonium ion, 181

Halogens, 4, 6, 8, 11, 14, 15, 24

Halohydrin, 155

Halothane, 90

Hardening of oils, 281

Hasenclever's method, 88

Heat of combustion, 146, 317

Heat of hydrogenation, 152

Heats of vaporization, 90

Heavy spar, 69

Heptane, 137, 138

Hetero atom, 126

Heterocyclic compounds, 124, 126

Hexagonal frame-work, 175

Hexane, 137, 138

Hexavalent chromium ion, 112

High carbon steel, 197

Homocyclic compounds, 125

Homologous series, 119, 132, 228

Homopolymer, 269

Hybridization of orbitals, 127

Hybridization, 105, 118, 128, 134, 151

Hybridized atomic orbital, 130

Hydrazine, 144, 240

Hydrides, 12, 13, 25, 45

Hydrocarbons, 119, 121, 122, 123, 125, 131, 136, 137, 142, 148, 156, 169, 170, 171, 173, 178, 180, 308, 310, 311

Hydrofluoric acid, 92, 147

Hydrogen chloride, 49, 159, 241

Hydrogen cyanide, 148, 160, 233, 234

Hydrogen halide, 152, 153, 156, 157

Hydrogenation of unsaturated

hydrocarbons, 142

Hydrogenation, 142, 143, 151, 152, 175, 176, 178, 222

Hydrogenolysis, 143

Hydrolysis of esters, 252

Hydrolysis, 28, 33, 39, 40, 48, 67, 180, 234, 242, 251, 252, 253, 258, 263, 275, 289, 285, 281, 278, 277

Hydrosphere, 307, 308

Hydroxides, 24, 25, 27, 31, 43, 62

Hydroxylamine, 240

Hydroxylation, 155

## I

Illuminating gas, 148

Incineration of industrial waste, 318

Incomplete oxidation, 146

Indicator, 42

Industrial Waste effluents, 314

Industrial waste, 307, 314, 317, 318

Ingots, 108

Inner transition metals, 100

Inorganic compounds, 57, 118, 119

Inorganic nomenclature committee, 105

Insecticides, 313

Internal combustion, 146

International Union of Pure and Applied

Chemistry (IUPAC), 138

Interstitial alloys, 103

Interstitial compounds, 103

Iodination, 181, 186, 197

Iodine number, 283

Iodized salt, 90

Iodoform test, 218, 238, 239

Ionic bonding, 12, 57

Ionic halides, 11

Ionic hydrides, 12, 25

Ionic radii, 6, 101

Ionic reactions, 119

Ionic reagent, 146

Ionization energy, 6, 7, 21, 24, 38, 44, 56, 68

Iron pyrite, 69, 70, 71

Iron, 24, 29, 43, 49, 51, 69, 71, 75, 97, 103, 104, 106, 107, 108, 109, 111, 180, 231, 277, 291, 292, 296, 301, 309

Isobutane, 124, 145

Isoelectronic negative ions, 6

Isoelectronic positive ions, 6

Isomerism, 118, 131, 132, 133, 134, 169

Isomers, 118, 131, 132, 133, 134, 137

IUPAC names of alcohols, 212

IUPAC names of ketones, 229

## K

Kaolin, 38, 45, 49

Kekule's formula, 175

Kerosene oil, 122

Ketones, 144, 155, 160, 213, 215, 217, 228, 230, 232-235, 238-245, 255, 273, 308

Knocking, 122, 123

Kolbe's electrolytic method, 143, 150

Krypton, 93

## L

Laboratory reagent, 63, 75

Leicithins, 64

Lactic acid, 234

Landfill, 312, 317, 318

Lanthanide contraction, 6

Lanthanides, 4, 5, 6, 100

Laughing gas, 5, 8

Law of octave, 1

Lead chromate, 51, 52, 112

Lead nitrate, 52, 59

Life molecules, 120, 268

Ligands, 104, 105

Lime mortar, 33

Lime water, 28

Lime, 32, 33, 118, 143, 158, 293, 269

Lime-sulphur sprays, 32

Limonite, 106

Lindlar's catalyst, 151

Lipids, 120, 268, 273, 279, 281, 284

Liquefaction of air, 91

Liquid ammonia, 92, 161, 293

Liquid neon, 91

Litharge, 51, 52

Lithosphere, 307, 308

Livestock waste, 312

Longest continuous chain, 138, 141

Lustrous crystals, 114

## M

Macromolecules, 64, 268, 277, 284

Macro-nutrients, 292

Magnetic moments, 101

Magnetite, 106

Malleable, 100, 107

Mendeleev's periodic table, 2

Manganate ion, 114

Manganese, 103, 106-109, 277, 292

Markownikov's rules, 153, 159

Massicot, 51

Mechanical properties, 100, 302

Medium carbon steel, 107

Melting point, 9, 11, 12, 21, 29, 38, 56, 100, 101, 107, 145, 158, 220, 259, 280

Menthone, 228

Mercuric nitrate, 63

Mercuric sulphate, 159

Metaphosphoric acid, 66, 68

Meta-stannic acid, 63

Meta-Directing groups, 188, 189

Metal chelates, 104

Metal fluorides, 92

Metal sulphates, 73

Metallic binding, 100

Metallic cations, 41

Metallic Character, 5, 8, 45, 57

Metallic elements, 14, 97

Metallic lattice, 103

Metallic lead, 123

Metallic structure, 100

Metalloids, 5, 8, 16, 46, 57, 62, 314

Metamerism, 132

Metamers, 132

Metasilicic acid, 48

Methanol, 150, 211, 213, 214, 215, 218, 219, 231, 237, 239, 271

Methylchloride, 148

Methylene group, 144

Methyl n-propyl ether, 132

Micro-nutrients, 292

Mild fluorinating agent, 92

Mild steel, 107

Milk of magnesia, 28

Milky quartz, 46

Mineral oil, 121

Mineral pyrolusite, 113

Modern periodic table, 2, 5

Molozonide, 155

Molten alkaline earth metals, 26

Molten metal, 43, 108

Molten sodium, 26, 161

Molten sulphur, 26

Molybdenum, 107, 231, 292

Monoatomic gases, 90

Monocarboxylic acid, 143, 251, 252

Monocyclic aromatic

hydrocarbon, 170, 171

Monomers, 155, 268, 269, 270, 272, 319

Monosubstituted benzene, 171, 187

Monosubstitution product, 173

Monosaccharides, 273

Moseley, 2

Mother-liquor, 39

Moulds, 32, 108

## N

Natural chromite, 111

Natural gas, 118, 120, 121, 297, 309

Negative electrode, 110

Nelson's cell, 30

Neoprene, 161, 162

Neutral coordination sphere, 104

Neutral molecules, 104

Neutral ligands, 104, 105

Neutral sulphite semi-chemical process, 300

Nickel, 44, 107

Ninhydrin test, 263

Nitration, 147, 183, 221

Nitric acid, 43, 52, 59, 60, 61, 62, 63, 70

Nitric oxide, 57, 61, 62, 63, 309, 311

Nitrosyl bromide, 58

Nitrous acid, 59, 60, 62

Nomenclature of carboxylic acid, 251

Nomenclature of alcohols, 212

Nomenclature of alkanes, 138

Nomenclature of alkenes, 141

Nomenclature of alkynes, 141

Nomenclature of amino acids, 260

Nomenclature of complex compounds, 105

Non-ionic character of organic compounds, 119

Non-metallic elements, 14, 97

Non-metallic oxides, 14

Non-metals, 5, 8, 10, 43, 57, 62, 68, 69

Non-Plated iron, 111

Non-polar organic solvents, 120

Non-polar solvents, 145

Non-stoichiometric Compounds, 103

Non-typical transition elements, 98

Normal elements, 2, 4

Nitroglycerine, 63

Nuclear reactors, 93

Nucleic acids, 120, 268, 273, 297, 287

Nucleophile, 146, 189, 199, 200, 201, 202, 203,

216, 220, 223, 233, 235, 236, 237, 239, 242, 255

Nucleophilic addition reaction, 232, 239

## O

Ortho and para directing groups, 188, 189

Octahedral crystals, 39

Octane, 122, 123

Oil of vitriol, 70

Oil spillage, 312

Old periodic table, 2

Olefins, 148

Oleum, 70, 71

Oligosaccharide, 274, 275

Open chain compounds, 123

Open chain hydrocarbons, 173

Open hearth process, 107

Optimum activity, 33

Organic chemistry, 46, 118, 119, 120,

126, 169, 194

Organic synthesis, 147, 204

Orientation, 187

Orthophosphoric acid, 65, 66, 67, 68

Orthoboric acid, 37, 38, 41

Outer transition metals, 100

Oxalate ligands, 105

Oxalic acid, 73, 114, 116, 251

Oxidation of alcohols, 217, 264

Oxidation reactions, 157, 160, 243

Oxidation state, 4, 5, 9, 10, 12, 20, 21, 39, 69,

91, 97, 100, 102

Oxidative cleavage, 253

Oxides of xenon, 93

Oxides, 8, 13, 15, 25-28, 37, 40, 45

Oxidizing agent, 59, 60, 62, 74, 112, 113, 114,

146, 242, 244, 252, 311, 315,

Oxyacids of nitrogen, 56, 60

Oxyacids of phosphorus, 67

Oxyborate ions, 38

Oxygen difluoride, 93

Ozone, 155, 187, 308, 311, 312, 316

Ozonide, 156

Ozonolysis, 155, 187

## P

Palladium-charcoal, 143

Paper industry, 299

Paper industry in Pakistan, 300, 303

Paper pulp, 33, 300, 314

Paraffins, 142, 145

Paramagnetic, 70

Paramagnetic behavior, 101

Paramagnetic effect, 102

Paramagnetic substances, 101

Paramagnetism, 101

Partial hydrogenation of alkynes, 150

Pauling scale, 13

Peculiar nature of carbon, 119

Pentane, 123, 131, 137, 145

Peptide linkage or bond, 263

Periodic classification, 1

Periodic law, 2

Periodic table, 1, 2, 4, 5, 6, 8, 10, 12, 23

Periodic trends, 5, 101

Periods, 2

Permanganate ion, 114

Peroxyacetyl nitrate (PAN), 308

Pesticides, 120, 291, 312, 313

Petroleum, 120

Phenol, 50, 63, 69, 74, 118, 120, 122,

178, 211, 219, 309, 318

Phenolphthalein, 42

Phenyl group, 171, 211, 223

Phenylhydrazine, 240

Phosphine, 66, 67

Phospholipids, 281, 284

Phosphorite, 67

Phosphorus acid, 66, 67

Phosphorus oxychloride, 65

Phosphorus pentachloride, 65, 224

Photochemical smog, 311

Picric acid, 63

Pig iron, 106

Pigments, 51, 52, 112

Planar hexagonal structure, 170

Plaster of paris, 29, 31, 32

Plated iron, 111

Polar solvents, 145

Polarizable anions, 23

Polarizing power, 12

Polyvinyl chloride (PVC) plastic, 89

Polyamide resin, 272

Polyatomic molecules, 69

Polyboric acids, 38

Hydrocarbons, 119, 121, 122, 123, 131,

136, 137, 169, 170, 172, 178

Polydentate ligand, 104

Polyethylene, 156, 318, 319

Polymeric halides, 11, 12

Polymeric, 69

Polymerization, 155, 190, 268, 269,

270, 271, 272, 318

Polymerization process, 270

Polymers, 156, 161, 162, 268, 270, 273

Polysaccharide, 274, 277

Polystyrene, 271

Polyester resin, 162, 259, 268, 272

Polythene, 156

Polyvinyl acetate, 162, 259, 268, 272

Polyvinyl chloride, 268, 269, 271

Portland cement, 32, 296, 297

Positive electrode, 110

Position isomerism, 132

Potassium chlorate, 111

Potassium dichromate, 112, 113, 252, 259

Potassium hexacyano ferrate, 105

Potassium iodide, 90, 113

Potassium manganate, 113

Potassium nitrate, 61, 293, 295

Potassium permanganate, 113, 114

Preparation of aldehydes, 230

Prevention from corrosion, 110

Prilling, 294, 294

Primary pollutants, 308

Propene, 122, 151

Properties of enzymes, 284, 285

Properties of transition elements, 98, 100

Propionaldehyde, 229

Protective coating, 111

Proteins, 57, 69, 119, 260, 263, 273, 277,

278, 279

Puddling furnace, 106

Puddling, 106

Pulping process, 300

Purification of water, 315

Purine, 287

Pyrimidine, 287

Pyroboric acid, 41

Pyrophosphoric acid, 68

## Q

Quinoline, 151

## R

Radioactive decay, 91

Radioactive metal, 68

Radiotherapy, 93

Radium isotopes, 91

Radon, 91

Rancidity of fats, 283,

Raney nickel, 151

Rare earth elements, 4

Rare gas, 90

Reaction zone, 92

Reactions of alcohols, 216

Reactions of alkenes, 151, 168

Reactions of amino acids, 262

Reactions of carboxylic

acids, 255

Reactions of phenol, 220, 221

Reactivity of alkanes, 145, 146

Reactions of Carboxylic Acids, 255

Reactivity of carboxyl group, 255

Recycling of waste, 318

Red phosphorus, 64, 67, 268

Reducing agent, 24, 39, 60, 63, 67, 145

Reducing flame, 40  
 Reducing smog, 311  
 Reforming, 122, 123  
 Replication, 287  
 Resonance energy, 177  
 Resonance method, 177  
 Resonance structures, 177  
 Reverberatory furnace, 48, 106  
 Rhombic prisms, 114  
 Rhombic, 52, 70  
 Ring compounds, 123, 124, 228, 283  
 RNA, 287  
 Rose quartz, 46  
 Rotary kiln, 297, 317

## S

Sabtier and Sendern's reaction, 142  
 Sacrificial corrosion, 111  
 Salt of permanganic acid, 113  
 Saponification number, 282  
 Saponification, 281  
 Saturated hydrocarbons, 122, 136, 148  
 Scrubbers, 71  
 Semi chemical process, 300  
 Semiconductor, 51  
 Semi-solid mass, 107  
 Setting of cement, 298  
 Shapes of molecules, 128  
 Shielding effect, 7, 37  
 Short periods, 4, 7, 9  
 Sigma bond, 128, 130, 175  
 Silane, 49  
 Silica, 46, 47, 48, 69, 108, 122, 296  
 Silicone film, 50, 51  
 Silicate glaze, 42  
 Silicones, 49, 50  
 Silver oxide catalyst, 154  
 Silver nitrate, 63, 162  
 Slaking of lime, 32  
 Smoky quartz, 46  
 Soda ash, 39  
 Soda lime, 33, 179  
 Sodium bisulphite, 234, 235, 244  
 Sodium borohydride, 242  
 Sodium dichromate, 112, 231  
 Sodium metaborate, 39, 40  
 Sodium nitroprusside test, 245  
 Sodium peroxenate, 93  
 Sodium salt, 39, 143, 179, 219, 238, 253  
 Sodium tetraborate, 39  
 Solid waste management, 316  
 Specific gravity, 62, 72  
 Stability of benzene, 175, 181, 190  
 Stable metal complexes, 104  
 Stadeler's process, 113  
 Starch, 73, 119, 215, 275, 276, 277, 295  
 Steam cracking, 122  
 Steroids, 283  
 Stibnite, 69  
 Straight chain structures, 173  
 Straight-chain hydrocarbons, 123  
 Stratosphere, 311, 312  
 Strecker synthesis, 262  
 Strong fluorinating agent, 92  
 Structural formula, 119, 131, 133, 260  
 Structural isomers, 131  
 Structure of amino acids, 261  
 Structure of chromate ion, 112  
 Structure of polymers, 269  
 Sub-groups, 123

Subshell, 6, 14  
 Substitution reactions, 147, 173, 175, 180, 181, 187, 189, 190, 198, 199, 202  
 Substitutional alloys, 103  
 Succinic acid, 150  
 Sucrose, 274, 275, 285  
 Sulphonation, 183, 221  
 Sulphonic acid, 183  
 Sulphur burners, 71  
 Superoxides, 23, 25  
 Symmetrical alkanes, 143, 204  
 Synthesis of amino acids, 262  
 Synthetic fibres, 75, 122

## T

Talc, 49  
 Tanning and dyeing, 41  
 Tensile strength, 43, 109  
 Terminal hydrogen atom, 138  
 Terpolymer, 270  
 Test of amino acids, 263  
 Tetraammine chloronitro-platinum (IV) sulphate, 105  
 Tetraatomic molecules, 64  
 Tetraboric acid, 39, 41, 42  
 Tetraethyl lead (TEL), 123  
 Tetragonal, 51  
 Tetrahedral geometry, 128, 142  
 Tetrahedral structure, 64  
 Tetrahedral, 11, 47, 48, 64, 128, 200  
 Tetrahedron, 129  
 Tetravalency of carbon, 128  
 Tetravalent carbon atom, 129  
 Thermal cracking, 122  
 Thermoplastic polymer, 270  
 Thermosetting polymer, 270  
 Thionyl chloride, 65, 197  
 Three-dimensional lattices, 11  
 Tin plating, 111  
 Tincal, 39  
 Titanium tetrachloride catalyst, 156  
 Tollen's test, 244  
 Toluene, 63, 174  
 Transition elements, 2, 4, 5, 10, 97, 98  
 Transition metals, 4, 98, 100, 103  
 Transition series, 97, 98, 100, 102  
 Triammine trinitrocobalt, 105  
 Tribasic acid, 68  
 Triclinic, 41  
 Triglyceride, 280, 281  
 Trinitrotoluene (TNT), 63  
 Triple phosphate, 295  
 Tripubic tetraoxide, 51  
 Tripositive ions, 98  
 Trivalent chromium compounds, 111  
 Trivalent chromium ion, 112  
 Trivial names, 137, 212, 251, 260  
 Triyne, 142  
 Tungsten, 62, 100, 107  
 Types of isomerism, 131  
 Types of pollution, 308  
 Types of polymers, 269  
 Typical elements, 2, 4  
 Typical non-metals, 69

## U

Unhybridized orbital, 130

Unreactivity of alkanes, 145, 146  
 Unsaturated dicarboxylic acids, 157  
 Unsaturated fatty acids, 143  
 Unsaturated hydrocarbons, 122, 136, 137  
 Unsymmetrical alkene, 153  
 unsymmetrical reagent, 153

## V

Valence shell, 10, 15, 20, 21, 47, 57, 97  
 Van der Waal's forces, 12  
 Vanadium, 100, 107  
 Vapour-phase nitration, 147  
 Variable valency, 100, 102  
 Vicinal dihalide, 150, 153, 156  
 Vicinal glycols, 155  
 Vinyl acetylene, 161  
 Vinyl alcohol, 159  
 Vital force theory, 118  
 Vitamins, 120, 285  
 Vitreous silica, 47, 48  
 Volatile liquids, 13, 223  
 Volatile, 42, 47, 69, 106, 122

## W

Washing soda, 28  
 Water disinfection, 316  
 Water pollution, 312  
 Weakly polar solvent, 145  
 Wet process, 296  
 White phosphorus, 57, 64, 66  
 Williamson's synthesis, 223  
 Wolf-Kishner's reduction, 144  
 Wrought iron, 106, 107, 301  
 Wurtz-Fittig reaction, 180

## X

Xenon tetra-fluorid, 92  
 Xenon oxytetrafluoride, 93  
 Xenon oxydifluoride, 93  
 Xenon tetraoxide, 93  
 Xenon trioxide, 93

## Y

Yellow crown, 112

## Z

Zero group elements, 10  
 Zinc blende, 69  
 Zinc chloride bath, 111  
 Zinc coating, 111  
 Zinc dust, 150, 180